

J. SCHNEIDER.
 FUNNEL ATTACHMENT FOR TANKS.
 APPLICATION FILED NOV. 21, 1910.

999,599.

Patented Aug. 1, 1911.

3 SHEETS—SHEET 1.

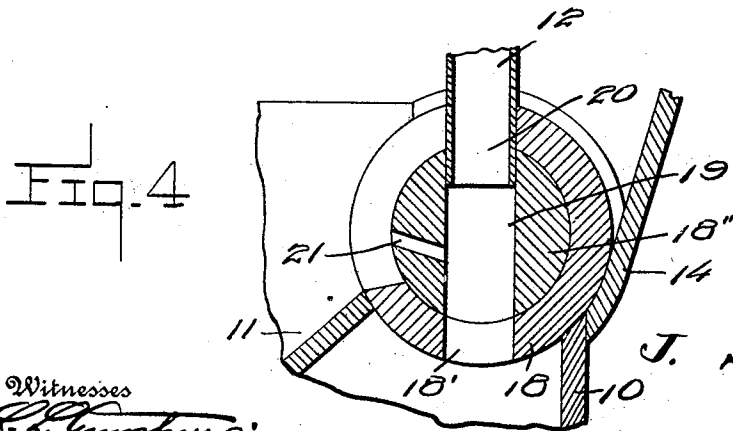
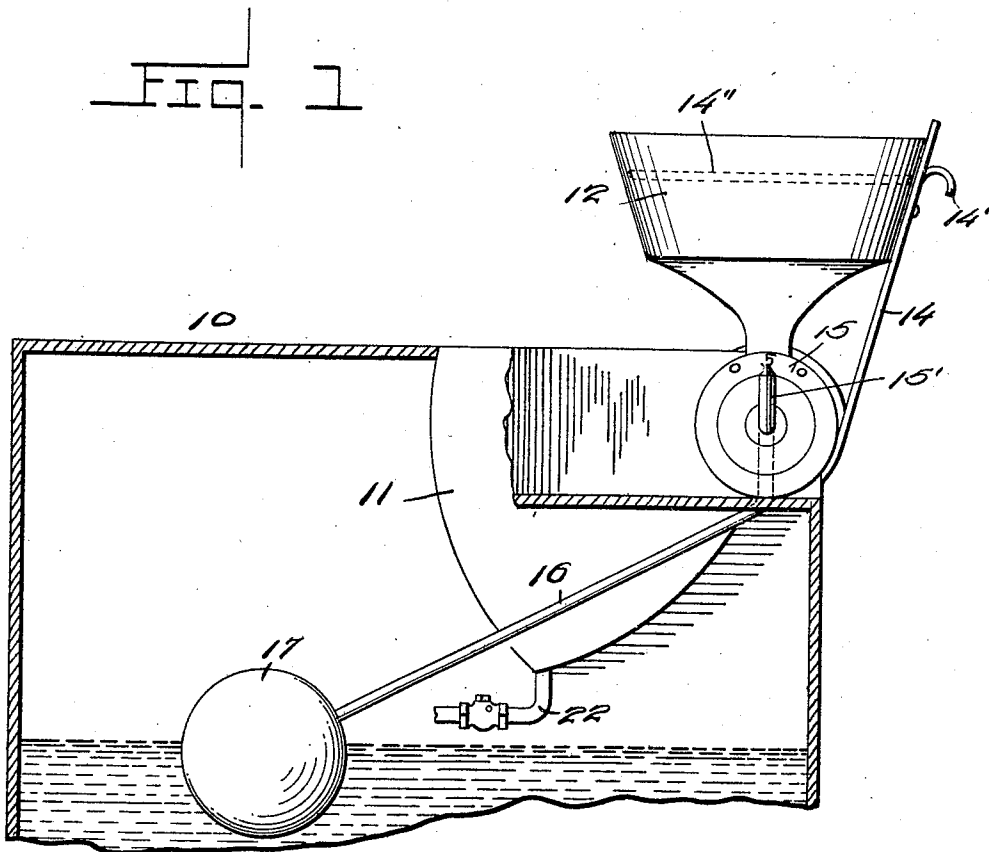

Inventor
J. Schneider,

Witnesses
E. H. Linsch...
Ernest H. Pley...

By *Harry E. Chandlee*
 Attorney

J. SCHNEIDER.
 FUNNEL ATTACHMENT FOR TANKS.
 APPLICATION FILED NOV. 21, 1910.

999,599.

Patented Aug. 1, 1911.

3 SHEETS—SHEET 2.

FIG. 2.

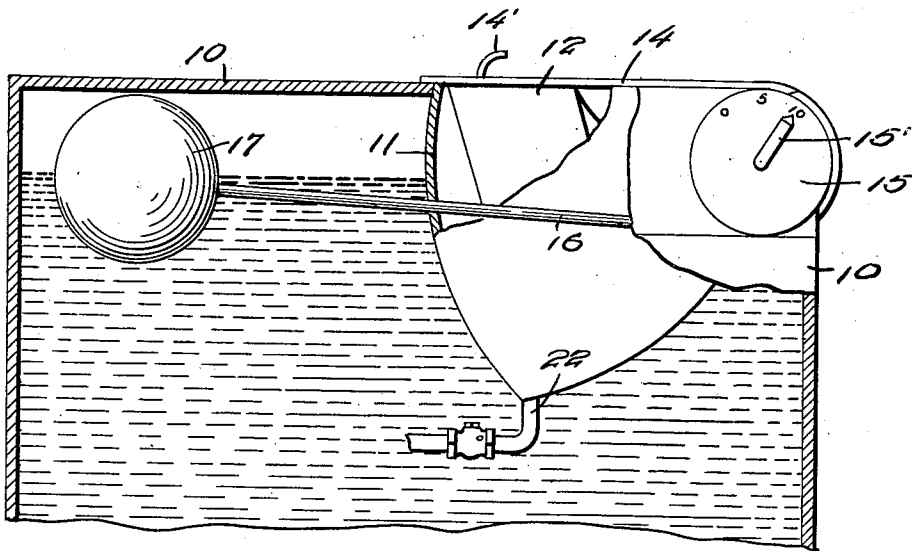

FIG. 5.

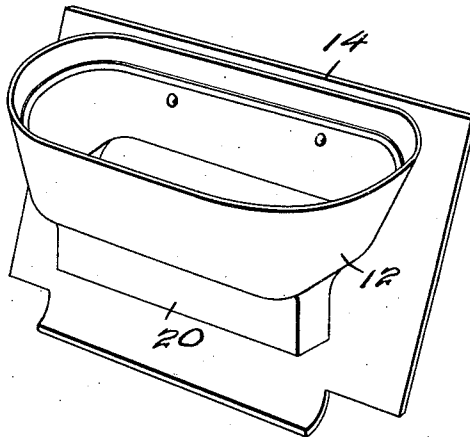
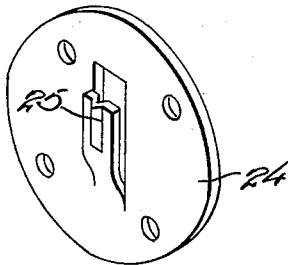

FIG. 6.

J. Schneider ^{Inventor}

Witnesses
E. P. Cunningham
Ernest F. Riley

By *Harry E. Chandler*
 Attorney

J. SCHNEIDER.
 FUNNEL ATTACHMENT FOR TANKS.
 APPLICATION FILED NOV. 21, 1910.

999,599.

Patented Aug. 1, 1911.

3 SHEETS-SHEET 3.

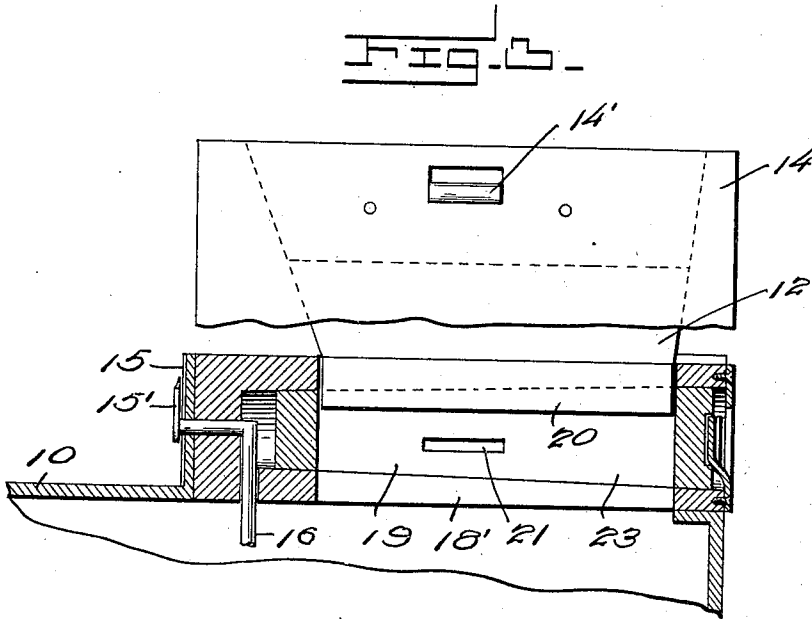
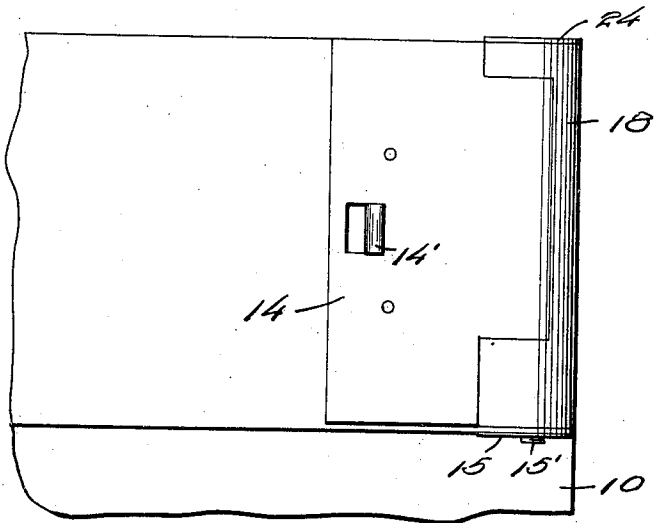

FIG. 7-



J. Schneider, ^{Inventor}

Witnesses
A. A. Armstrong
Ernest F. Riley

By *Harry E. Chandler*
 Attorney

UNITED STATES PATENT OFFICE.

JOHN SCHNEIDER, OF BRIDGEPORT, CONNECTICUT.

FUNNEL ATTACHMENT FOR TANKS.

999,599.

Specification of Letters Patent.

Patented Aug. 1, 1911.

Application filed November 21, 1910. Serial No. 593,426.

To all whom it may concern:

Be it known that I, JOHN SCHNEIDER, a citizen of the United States, residing at Bridgeport, in the county of Fairfield and State of Connecticut, have invented certain new and useful Improvements in Funnel Attachment for Tanks, of which the following is a specification.

This invention relates to funnel attachments for tanks.

The primary object of the invention is to provide a funnel which is a part of the tank and which remains in the tank after the same has been filled.

A further object of the invention is to provide a valve mechanism which allows the liquid to flow into the tank when the funnel is raised to a filling position.

Other objects and advantages will be apparent from the following description, and it will be understood that changes in the specific structure shown and described may be made within the scope of the claims without departing from the spirit of the invention.

In the drawings: Figure 1 is an end view of a tank partly in section, the funnel being in position to be filled, Fig. 2 is a similar view showing the lid in its closed position, Fig. 3 is a side elevation of the tank partly in section showing the funnel in an open position, Fig. 4 is a detail view of the valve mechanism, Fig. 5 is a detail view of the latch member forming a part of said valve mechanism, Fig. 6 is a detail view of the funnel, and Fig. 7 is a top plan view of the tank, the lid being closed.

In the drawings 10 designates a supply tank, said tank being provided with a compartment 11, the walls of which conform in shape to a funnel member 12, said funnel member having attached thereto a lid 14 which when the funnel member is in a closed position forms a closure for the compartment 11, said lid being provided with a curved lifting member 14'. A dial 15 is secured to one side of the tank, the dial member 15' being provided with an arm 16 to which the float 17 is attached. Said float being adapted to actuate the dial finger to register the amount of liquid contained within the tank. A concaved gutter or channel 18 is formed adjacent the compartment 11, said channel being provided with the elongated slot 18'. A valve core 18'' is positioned within this channel, said valve core

being rotatably supported. The valve core is provided with the longitudinally arranged aperture 19 in which is inserted the end portion 20 of the funnel 12, the opening in said funnel and the opening in said core being adapted to register with the slot formed in the channel 18 when the funnel is raised to a filling position, thus permitting the fluid to enter the tank 10. A vent 21 is adapted to take up any over-flow and transfer the same to the tank through the passage-way 22.

It will be seen that when the funnel is in its closed position, the lid 14 closing the compartment 11 the core will be so rotated that its solid portion 23 will close the openings in the channel thus effectually closing the tank.

The end portion of the tank adjacent the channel is reduced to accommodate a plate 24 which is formed with a resilient V-shaped fin or projection 25 which is adapted to register with any one of a plurality of V-shaped slots formed in the end portion of the core. This construction forms a means for holding the funnel while in either a closed or open position, thus allowing the operator to use both hands in the manipulation of the receptacle from which the liquid is supplied. The funnel is provided with a hoop 14'' which is adapted to retain a chamois in position.

Particular attention is called to the peculiar construction of the core member and the manner in which the same accommodates the tapered portion of the funnel.

The many advantages of a construction of this sort will be clearly apparent, as the same forms a convenient filling device which in itself is a closure for the aperture through which the liquid is fed. Attention is also called to the fact that the device may be easily manufactured and the various parts readily assembled.

What is claimed is:

1. A filling device for tanks consisting of a revoluble core member, said core member being arranged within a channel formed in the tank, a funnel adapted to be supported by said core member, said tank formed with a compartment to receive said funnel, a passage way connecting an aperture in said core with said compartment when the funnel is in a vertical position, a plate arranged adjacent one end of said core, said plate being provided with a resilient extension, said extension being formed

with a struck-up portion adapted to engage a plurality of channels formed on the end portion of the core.

2. A filling device for tanks consisting of a core member, said core member being rotatably supported within a channel formed in the tank, said channel being provided with a longitudinally extending aperture, said core member being provided with an opening adapted to register with said aperture, a funnel, the reduced portion of said funnel extending within the opening in said core, said core being adapted to close the aperture in the channel as the same is rotated.

3. The combination with a tank, of filling device, consisting of a pivotally supported funnel, a revoluble core adapted to support

said funnel, means for rigidly holding said core in a plurality of positions, said tank being provided with a compartment adapted to accommodate said funnel, said funnel being provided with a lid adapted to form a closure for said compartment.

4. The combination with a tank, of filling device consisting of a pivotally supported funnel, said tank being provided with a compartment adapted to accommodate said funnel, and a lid secured to said funnel, said lid forming a closure for said compartment.

In testimony whereof I affix my signature, in the presence of two witnesses.

JOHN SCHNEIDER.

Witnesses:

H. M. GRERORY,

B. F. PIKE.

Copies of this patent may be obtained for five cents each, by addressing the "Commissioner of Patents, Washington, D. C."