

(19) World Intellectual Property Organization
International Bureau



(43) International Publication Date
9 November 2006 (09.11.2006)

PCT

(10) International Publication Number
WO 2006/119034 A2

(51) International Patent Classification:
A61F 2/44 (2006.01)

(21) International Application Number:

PCT/US2006/016292

(22) International Filing Date: 28 April 2006 (28.04.2006)

(25) Filing Language: English

(26) Publication Language: English

(30) Priority Data:
11/120,750 3 May 2005 (03.05.2005) US

(71) Applicant (for all designated States except US): ANULEX
TECHNOLOGIES, INC. [US/US]; 5600 Rowland Road,
Suite 280, Minnetonka, Minnesota 55343 (US).

(72) Inventors; and

(75) Inventors/Applicants (for US only): CAUTHEN, III,
Joseph, C. [US/US]; 8224 SW 28th Place, Gainesville,
Florida 32607 (US). BURNS, Matthew, M. [US/US];
1180 Loma Linda Avenue, Orono, Minnesota 55364 (US).
WALES, Lawrence, W. [US/US]; 1654 Currie Street
North, Maplewood, Minnesota 55119 (US). DUKART,
Brian, L. [US/US]; 7809 Aster Drive, Brooklyn Park, Min-
nesota 55428 (US). WESSMAN, Bradley, J. [US/US];
8026 Marsh Reach Drive, Wilmington, North Carolina
28411 (US). HOUFBURG, Rodney, L. [US/US]; 16285
Parkview Drive SEX, Prior Lake, Minnesota 55372 (US).
BENTLEY, Ishmael [US/US]; 4287 Sun Cliff Road,
Eagan, Minnesota 55122 (US).

(74) Agent: GARRETT, Arthur, S.; Finnegan, Henderson,
Farabow, Garrett & Dunner LLP, 901 New York Avenue,
N.W., Washington, District Of Columbia 20001-4413 (US).

(81) Designated States (unless otherwise indicated, for every
kind of national protection available): AE, AG, AL, AM,
AT, AU, AZ, BA, BB, BG, BR, BW, BY, BZ, CA, CH, CN,
CO, CR, CU, CZ, DE, DK, DM, DZ, EC, EE, EG, ES, FI,
GB, GD, GE, GH, GM, HR, HU, ID, IL, IN, IS, JP, KE,
KG, KM, KN, KP, KR, KZ, LC, LK, LR, LS, LT, LU, LV,
LY, MA, MD, MG, MK, MN, MW, MX, MZ, NA, NG, NI,
NO, NZ, OM, PG, PH, PL, PT, RO, RU, SC, SD, SE, SG,
SK, SL, SM, SY, TJ, TM, TN, TR, TT, TZ, UA, UG, US,
UZ, VC, VN, YU, ZA, ZM, ZW.

(84) Designated States (unless otherwise indicated, for every
kind of regional protection available): ARIPO (BW, GH,
GM, KE, LS, MW, MZ, NA, SD, SL, SZ, TZ, UG, ZM,
ZW), Eurasian (AM, AZ, BY, KG, KZ, MD, RU, TJ, TM),
European (AT, BE, BG, CH, CY, CZ, DE, DK, EE, ES, FI,
FR, GB, GR, HU, IE, IS, IT, LT, LU, LV, MC, NL, PL, PT,
RO, SE, SI, SK, TR), OAPI (BF, BJ, CF, CG, CI, CM, GA,
GN, GQ, GW, ML, MR, NE, SN, TD, TG).

Published:

— without international search report and to be republished
upon receipt of that report

For two-letter codes and other abbreviations, refer to the "Guid-
ance Notes on Codes and Abbreviations" appearing at the begin-
ning of each regular issue of the PCT Gazette.

(54) Title: METHOD AND APPARATUS FOR THE TREATMENT OF THE INTERVERTEBRAL DISC ANNULUS

(57) Abstract: The present invention provides methods and devices for treating the annulus of an intervertebral disc. The methods and devices can employ an expandable treatment device which is deployed at least partially in the subannular space. Fixation devices and methods are also disclosed, which help to secure the treatment device in place.

WO 2006/119034 A2

METHOD AND APPARATUS FOR THE TREATMENT OF THE INTERVERTEBRAL DISC ANNULUS

Cross-Reference to a Related Applications

[001] This application claims priority to U.S. Patent Application No. 11/120,750 filed May 3, 2005, which is a continuation-in-part of U.S. Patent Application No. 10/352,981 filed January 29, 2003 and a continuation-in-part of U.S. Patent Application No. 10/327,106 filed December 24, 2002, each of which are continuations-in-part of U.S. Patent Application No. 10/133,339 filed April 29, 2002, which is a continuation-in-part of US Patent Application No. 09/947,078, filed September 5, 2001, now U.S. Patent 6,592,695, issued July 15, 2003, which is a continuation of U.S. Patent Application No. 09/484,706, filed January 18, 2000, which claims the benefit of U.S. Provisional Application No. 60/160,710, filed October 20, 1999. This application also claims, through Application 10/133,339 the benefit of U.S. Provisional Application No. 60/309,105, filed July 31, 2001. This application is also related to, and claims the benefit of, U.S. Patent Application 10/075,615, filed on February 15, 2002. All are incorporated herein by reference in their entirety.

Field of the Invention

[002] The invention generally relates to methods and devices for the closure, sealing, repair and/or reconstruction of an intervertebral disc annulus, and accompanying delivery devices and tools, and their methods of use. The repair can be of an aperture in the disc wall, or a weakened or thin portion. The term "aperture" refers to a hole in the annulus that is a result of a surgical incision or dissection into the intervertebral disc annulus, or the consequence of a naturally occurring tear (rent). The invention generally relates to surgical devices and methods for the treatment of intervertebral disc wall repair or reconstruction. The invention further relates to an annular repair device, or stent, for annular disc repair. These stents can be of natural or synthetic materials. The effects of said reconstruction is restoration of disc wall integrity, which may reduce the failure

rate (3-21%) of a common surgical procedure (disc fragment removal or discectomy), or advantageously provide a barrier to intradiscal material migration.

Background of the Invention

[003] The spinal column is formed from a number of bony vertebrae, which in their normal state are separated from each other by intervertebral discs. These discs are comprised of the annulus fibrosus, and the nucleus pulposus, both of which are soft tissue. The intervertebral disc acts in the spine as a crucial stabilizer, and as a mechanism for force distribution between adjacent vertebral bodies. Without a competent disc, collapse of the intervertebral disc may occur, contributing to abnormal joint mechanics and premature development of degenerative and/or arthritic changes.

[004] The normal intervertebral disc has an outer ligamentous ring called the annulus surrounding the nucleus pulposus. The annulus binds the adjacent vertebrae together and is constituted of collagen fibers that are attached to the vertebrae and cross each other so that half of the individual fibers will tighten as the vertebrae are rotated in either direction, thus resisting twisting or torsional motion. The nucleus pulposus is constituted of soft tissue, having about 85% water content, which moves about during bending from front to back and from side to side.

[005] The aging process contributes to gradual changes in the intervertebral discs. The annulus loses much of its flexibility and resilience, becoming more dense and solid in composition. The aging annulus may also be marked by the appearance or propagation of cracks or fissures in the annular wall. Similarly, the nucleus desiccates, increasing viscosity and thus losing its fluidity. In combination, these features of the aged intervertebral discs result in less dynamic stress distribution because of the more viscous nucleus pulposus, and less ability to withstand localized stresses by the annulus fibrosus due to its desiccation, loss of flexibility and the presence of fissures. Fissures can also occur due to disease or other pathological conditions. Occasionally fissures may form rents through the annular wall. In these instances, the nucleus pulposus is urged outwardly from the subannular space through a rent, often into the spinal

column. Extruded nucleus pulposus can, and often does, mechanically press on the spinal cord or spinal nerve rootlet. This painful condition is clinically referred to as a ruptured or herniated disc.

[006] In the event of annulus rupture, the subannular nucleus pulposus migrates along the path of least resistance forcing the fissure to open further, allowing migration of the nucleus pulposus through the wall of the disc, with resultant nerve compression and leakage of chemicals of inflammation into the space around the adjacent nerve roots supplying the extremities, bladder, bowel and genitalia. The usual effect of nerve compression and inflammation is intolerable back or neck pain, radiating into the extremities, with accompanying numbness, weakness, and in late stages, paralysis and muscle atrophy, and/or bladder and bowel incontinence. Additionally, injury, disease or other degenerative disorders may cause one or more of the intervertebral discs to shrink, collapse, deteriorate or become displaced, herniated, or otherwise damaged and compromised.

[007] Surgical repairs or replacements of displaced or herniated discs are attempted approximately 390,000 times in the USA each year. Historically, there has been no known way to repair or reconstruct the annulus. Instead, surgical procedures to date are designed to relieve symptoms by removing unwanted disc fragments and relieving nerve compression. While results are currently acceptable, they are not optimal. Various authors report 3.1- 21% recurrent disc herniation, representing a failure of the primary procedure and requiring re-operation for the same condition. An estimated 10% recurrence rate results in 39,000 re-operations in the United States each year.

[008] An additional method of relieving the symptoms is thermal annuloplasty, involving the heating of sub-annular zones in the non-herniated painful disc, seeking pain relief, but making no claim of reconstruction of the ruptured, discontinuous annulus wall.

[009] Some have also suggested that the repair of a damaged intervertebral disc might include the augmentation of the nucleus pulposus, and various efforts at nucleus pulposus replacement have been reported. The

present invention is directed at the repair of the annulus, whether or not a nuclear augmentation is also warranted.

[010] In addition, there has been experimentation in animals to assess various surgical incisions with and without the direct surgical repair of the annulus. These studies were performed on otherwise healthy animals and involved no removal or augmentation of nucleus pulposus. The authors of these experiments conclude that direct repair of the annulus does not influence the healing of the disc.

[011] The present inventors have found, advantageously and contrary to accepted practice, that the annulus tissue may be sutured and that annular healing may be facilitated by reapproximation, reinforcement, and/or support of annular tissue. Methods and devices for carrying out annular repair and/or reconstruction are a subject of the present invention.

Brief Summary of the Invention

[012] The present inventions provide methods and related devices for reconstruction of the disc wall in cases of displaced, herniated, thinned, ruptured, or otherwise damaged or infirm intervertebral discs. In accordance with the invention, a method is disclosed for intervertebral disc reconstruction for treating a disc having an aperture, weakened or thin portion in the wall of the annulus fibrosis of the intervertebral disc. Repair, reconstruction, sealing, occluding an aperture, weakened or thin portion in the wall of the annulus may prevent or avoid migration of intradiscal material from the subannular space.

[013] The method of the invention includes, in one embodiment, the steps of providing a first delivery tool having a proximal end and a distal end, the distal end carrying a treatment device; providing at least one second delivery tool having a proximal end and a distal end, the distal end carrying a fixation element; introducing the distal end of the first delivery tool at least partially into subannular intervertebral disc space; deploying said treatment device; introducing the distal end of said at least one second delivery tool at least partially into subannular intervertebral disc space; and deploying at least one fixation device into, or

through, the wall of an annulus to hold said treatment device at least partially within the subannular intervertebral disc space; and removing the delivery tools.

[014] A fixation device useful for intervertebral disc reconstruction for treating a disc having an aperture, weakened, or thin portion in the wall of the annulus fibrosis of said intervertebral disc, said device, in one embodiment comprises at least one anchor portion and at least one band.

[015] A treatment device, according to one embodiment, comprises a mesh patch that radially expands in the subannular space.

[016] The invention also comprises delivery tools for delivering fixation devices and treatment devices, as well as kits comprising devices and tools.

[017] The objects and various advantages of the invention will be apparent from the description which follows. In general, the implantable medical treatment devices are placed, positioned, and subsequently affixed in the annulus to reduce re-extrusion of the nucleus or other intradiscal material through an aperture by: establishing a barrier or otherwise closing or partially closing the aperture; and/or helping to restore the natural integrity of the wall of the annulus; and/or promoting healing of the annulus. Increased integrity and faster and/or more thorough healing of the aperture may reduce future recurrence of herniation of the disc nucleus, or intradiscal material, from the intervertebral disc, and the recurrence of resulting back pain. In addition, it is believed that the repair of the annular tissue could promote enhanced biomechanics and reduce the possibility of intervertebral disc height collapse and segmental instability, thus possibly avoiding back pain after a surgical procedure.

[018] Moreover, the repair of an aperture (after for example, a discectomy procedure) with the reduction of the re-extrusion of the nucleus may also advantageously reduce adhesion formation surrounding the nerve roots. The nuclear material of the disc is toxic to the nerves and is believed to cause increased inflammation surrounding the nerves, which in turn can cause increased scar formation (adhesions or epidural fibrosis) upon healing. Adhesions created around the nerve roots can cause continued back pain. Any reduction in adhesion formation is believed to reduce future recurrence of pain.

[019] The methods and devices of the present inventions may create a mechanical barrier to the extrusion of intradiscal material (i.e., nucleus pulposus, or nuclear augmentation materials) from the disc space, add mechanical integrity to the annulus and the tissue surrounding an aperture, weakened, or thin portion of the wall of the annulus, and promote faster and more complete healing of the aperture, weakened or thin portion

[020] Although much of the discussion is directed toward the repair of the intervertebral disc after a surgical procedure, such as discectomy (a surgical procedure performed to remove herniated fragments of the disc nucleus), it is contemplated that the devices of the present invention may be used in other procedures that involve access (whether induced or naturally occurring) through the annulus of the intervertebral disc, or prophylactic application to the annulus. An example of another procedure that could require a repair technique involves the replacement of the nucleus (nucleus replacement) with an implantable nucleus material to replace the functioning of the natural nucleus when it is degenerated. The object of the invention in this case would be similar in that the repair would maintain the replacement nucleus within the disc space.

[021] According to an embodiment of the invention, a sub-annular device can be employed to repair an aperture, degenerated, weakened, or thin portion in an intervertebral disc annulus. The device can be secured in place with one or more fixation elements, such as sutures or anchors which may also be used to re-approximate the tissues surrounding the aperture, degenerated, weakened, or thin portion. The invention, through involvement of the sub-annular space and wall for the repair of the aperture has several advantages. The first advantage of a repair that involves a sub-annular surface derives itself from the physical nature of a circular (or an elliptical) compressed chamber with a radius, like an intervertebral disc. Sealing the inside wall has the inherent advantage of being at a smaller radius of curvature versus the outer wall and thus, according to LaPlace's Law, the patch would be subjected to lower stresses at any given pressure, all else held equal.

[022] Another advantage of utilizing the inner surface to accomplish sealing is that the natural pressure within the disc can enhance the seating of the device against the inner wall of the disc space. Conversely, if the repair is performed on the outer surface of the annulus there is an inherent risk of leakage around the periphery of the device, with the constant exposure to the pressure of the disc.

[023] Another advantage of the present invention in utilizing an inner surface of the annulus is the reduction of the risk of having a portion of the device protruding from the exterior surface of the annulus. Device materials protruding from the exterior of the annulus pose a risk of damaging the nerve root and/or spinal canal which are in close proximity. Damage to these structures can result in continued pain, incontinence, bowel dysfunction and paralysis.

[024] Some embodiments of the present invention may also incorporate the concept of pulling the tissues together that surround the aperture, the inner surface, and the outer surface of the annulus to help close the aperture, increase the integrity of the repair, and promote healing.

[025] An example of the technique and placement of the device according to one embodiment of the invention is as follows:

[026] 1. A treatment device is actuated into a delivery configuration by delivery device and passed through an aperture in the wall of the annulus, positioning a treatment device in the subannular disc space, as shown in FIG. 3A – 3C.

[027] 2. The delivery device is actuated to deploy the treatment device, as shown in FIGs. 3D.

[028] 3. Holding the treatment device in the deployed configuration, a fixation instrument is employed to introduce one or more fixation elements into, or through, the annulus to secure the treatment device and subsequently removed, as shown in FIGs. 2, 5 and 6.

[029] 4. The delivery device is disengaged from the treatment device.

[030] Several devices according to the present invention can be used to practice the above illustrative inventive steps to seal, reconstruct and/or repair the

intervertebral disc. In some of the representative devices described herein, there is: a reconfigurable device (note: patch, stent, device, mesh, barrier, and treatment device are here used interchangeably) that has, in use, at least a portion of the device in the sub-annular space of the intervertebral disc annulus; a means to affix the at least a portion of the device to or within at least a portion of the annulus; a means to draw the patch or fixation device into engagement with the annular tissue in tension to thereby help reduce the relative motion of the surfaces of the aperture and/or annulus after fixation, and thus promote healing. Reducing motion of the annular surfaces may provide the optimal environment for healing.

[031] Some of the concepts disclosed hereinbelow accomplish these objectives, as well as may advantageously additionally incorporate design elements to reduce the number of steps (and time), and/or simplify the surgical technique, and/or reduce the risk of causing complications during the repair of the intervertebral disc annulus. In addition, the following devices may become incorporated by the surrounding tissues, or to act as a scaffold in the short-term (3 – 6 months) for tissue incorporation.

[032] In an exemplary embodiment, one or more mild biodegradable surgical sutures can be placed at about equal distances along the sides of a pathologic aperture in the ruptured disc wall (annulus) or along the sides of a surgical dissection or incision in the annular wall, which may be weakened or thinned. The sutures hold an expandable device to a subannular surface of the annulus.

[033] Sutures are then drawn in tension and secured in such a fashion as to draw the expandable device into engagement with the annular tissue, and also to help effect closure of the aperture, to enhance natural healing and subsequent reconstruction by natural tissue (fibroblasts) crossing the gap now bridged by the device in the disc annulus.

[034] In an exemplary embodiment, the method can be augmented by creating a subannular barrier in and across the aperture by placement of a patch of biocompatible material acting as a bridge or a scaffold, providing a platform for

traverse of fibroblasts or other normal cells of repair existing in and around the various layers of the disc annulus.

[035] Such biocompatible materials may be, for example, medical grade biocompatible fabrics or fibers, biodegradable polymeric sheets, or form fitting or non-form fitting fillers for the cavity created by removal of a portion of the disc nucleus pulposus in the course of the disc fragment removal or discectomy. The prosthetic material can be placed in and around the intervertebral space, created by removal of the degenerated disc fragments.

[036] Additional objects and advantages of the invention will be set forth in part in the description which follows, and in part will be obvious from the description, or may be learned by practice of the invention. The objects and advantages of the invention will be realized and attained by means of the elements and combinations particularly pointed out in the appended claims.

[037] It is to be understood that both the foregoing general description and the following detailed description are exemplary and explanatory only and are not restrictive of the invention, as claimed.

Brief Description of the Drawings

[038] The accompanying drawings, which are incorporated in and constitute a part of this specification, illustrate illustrative embodiments of the invention and, together with the description, serve to explain the principles of the invention.

[039] **FIG. 1** shows a primary closure of an opening in the disc annulus.

[040] **FIGs. 2A-2B** show a primary closure with a stent.

[041] **FIGs. 3A-3D** show an annulus stent being inserted into and expanded within the disc annulus.

[042] **FIGs. 4A-4C** shows a perspective view of a further illustrative embodiment of an annulus stent, and collapsed views thereof.

[043] **FIGs. 5A-5C** show the annulus stent of FIG. 4A being inserted into the disc annulus.

[044] **FIGs. 6A-6C** show a method of inserting the annulus stent of FIG. 4A into the disc annulus.

[045] **FIG. 7** shows an illustrative embodiment of an introduction device for an annulus stent.

[046] **FIG. 8** shows a variation of the device depicted in FIG. 7.

[047] **FIGS. 9A-9C** show an exemplary introduction tool for use with the devices of FIGs. 7 and 8 with a stent deflected.

[048] **FIGS. 10A-10B** show a still further illustrative embodiment of an annulus stent employing secondary barbed fixation devices.

[049] **FIG. 11A** shows a herniated disc in perspective view, and **FIG. 11B** shows the same disc after discectomy.

[050] **FIGS. 12A-12G** show a still further illustrative embodiment of an introduced and expanded annulus stent/patch being fixated and the aperture reapproximated.

[051] **FIGS. 13A-13C** schematically depict a still further embodiment of the invention where an expandable stent/patch is tethered in situ using a cinch line.

[052] **FIGS. 14A-14C** schematically depict the patch of FIG. 13 being fixated through use of a barbed surgical staple device and a cinch line.

[053] **FIGS. 15A-15C** schematically depict a still further embodiment of the invention where an expandable stent/patch is tethered in situ using a cinch line.

[054] **FIGS. 16A-16C** schematically depict the stent/patch of FIG. 15 being fixated through use of a barbed surgical staple device that penetrates the patch/stent and a cinch line.

[055] **FIG. 17** depicts an exemplary use of filler material within the aperture during placement of a patch/stent tethered by a cinch line.

[056] **FIGS. 18A-18E** show exemplary embodiments of various additional patch/stent fixation techniques.

[057] **FIGS. 19** shows a still further illustrative embodiment of a stent/patch having a frame.

[058] **FIGS. 20A-20C** show a still further exemplary embodiment of the invention having external fixation anchors.

[059] **FIGS. 21A-21C** show still further embodiments of the invention having external fixation anchors.

[060] **FIGs. 22A-22C** show still further embodiments of the invention having external fixation anchors.

[061] **FIG. 23** shows a delivered configuration of fixation means that may result from the use of a single, or multiple, devices to deliver multiple barbs, anchor, or T-anchors sequentially or simultaneously.

[062] **FIGs 24A-24B** show an illustrative configuration of an anchor band delivery device.

[063] **FIGs 25A-25D** show an anchor band delivery device comprising two devices, each with at least one T-anchor (barbs) and band with pre-tied knot and optional knot pusher according to illustrative embodiments of the invention.

[064] **FIG 26** shows an anchor and band delivery device according to one embodiment of the invention.

[065] **FIGs. 27A-27B** show, respectively, a lateral view of a still further exemplary embodiment of the present invention having a braided arrangement in a collapsed configuration and an axial view of the exemplary embodiment in an expanded configuration.

[066] **FIG. 28** shows a lateral view of the exemplary embodiment of FIG. 27A in a collapsed configuration mounted on an illustrative delivery device.

[067] **FIG. 29** shows a lateral cutaway view of the exemplary embodiment of FIG. 27A in a collapsed configuration.

[068] **FIG. 30** shows a lateral cutaway view of the exemplary embodiment of FIG. 27B in an expanded configuration.

[069] **FIG. 31** shows a lateral view of an illustrative delivery member as shown in the exemplary embodiment of FIGs. 29 and 30.

[070] **FIG. 32** shows a lateral view of an exemplary embodiment of the invention in an expanded configuration subannularly.

[071] **FIG. 33** shows a transverse view of a treatment device mounted on a delivery tool in an unexpanded configuration in the subannular cavity.

[072] **FIG. 34** shows a transverse view of the treatment device being deployed into an expanded configuration in the subannular cavity.

[073] **FIG. 35** shows a transverse view of the treatment device fully deployed and adjacent the annular wall.

[074] **FIG. 36** shows a transverse view of the placement of a fixation element delivery device into the deployed treatment device.

[075] **FIG. 37** shows a transverse view of the placement of a fixation element through the treatment device and the annular wall.

[076] **FIG. 38** shows a transverse view of after affixing a fixation element delivered in FIG. 37 and partial removal of the fixation element delivery device.

[077] **FIG. 39** shows a transverse view of the fixation element after removal of the fixation element delivery tool.

[078] **FIG. 40** shows a transverse view of an additional fixation element locked in place on the opposite side of the treatment device.

[079] **FIG. 41** shows a transverse view of the removal of the treatment device delivery tool.

[080] **FIG. 42** shows an transverse view of an illustrative embodiment of a treatment device mounted on a delivery tool in an unexpanded configuration in the subannular cavity.

[081] **FIG. 43** shows a transverse view of after affixing a fixation element to the treatment device of FIG. 42.

[082] **FIG. 44** shows a transverse view of the placement of a fixation element delivery tool through the treatment device and the annular wall.

[083] **FIG. 45** shows a transverse view of the placement of an additional fixation element through the treatment device and the annular wall.

[084] **FIG. 46** shows a transverse view after the removal of the fixation element delivery tool.

[085] **FIG. 47** is a view of the anchor band delivery tool pre-deployment in cross section.

[086] **FIG. 48** shows a detail of the distal end of the anchor band (fixation element) delivery tool in cross section.

[087] **FIG. 49** shows a detail of the slide body and cannula anchor of an exemplary fixation element delivery tool in cross section.

[088] **FIG. 50** is a view of the anchor band delivery tool in cross section during a deployment cycle.

[089] **FIG. 51** is a detail of the distal end of the anchor band delivery tool depicted in FIG. 50.

[090] **FIG. 52** shows a detail of the slide body and cannula anchor of an exemplary fixation element delivery tool in cross section during a deployment cycle.

[091] **FIG. 53** shows a detail of the suture retention block and blade assembly of the anchor band delivery tool.

[092] **FIG. 54** is a view of the anchor band delivery tool in cross section during the cutting of the suture tether and release of the anchor band.

[093] **FIG. 55** shows a detail of the distal end of the anchor band delivery tool during release of the anchor band.

[094] **FIG. 56** shows a detail of the suture retention block and blade assembly of the anchor band delivery tool during the cutting of the tether.

[095] **FIG. 57** depicts an illustrative embodiment of a therapeutic device delivery tool (TDDT)

[096] **FIG. 58** shows a detail of the distal end of the therapeutic device delivery tool with a therapeutic device mounted thereon.

[097] **FIG. 59** depicts the deployment of a therapeutic device using the TDDT.

[098] **FIG. 60** depicts a detail of the distal end of the TDDT during deployment of a therapeutic device.

[099] **FIG. 61** depicts the TDDT during release of the therapeutic device.

[0100] **FIG. 62** is a detail view of the distal end of the TDDT during release of the therapeutic device.

[0101] **Fig. 63** is a plan view along the axis of an expanded exemplary therapeutic device, showing the engagement of the TDDT latch.

[0102] **Fig. 64** is a plan view along the axis of an expanded exemplary therapeutic device, showing the disengagement of the TDDT latch.

[0103] **FIG. 65** illustrates an exemplary sizing tool used to assess the treatment site prior to delivery of patch, anchor bands or other treatment devices.

[0104] **FIGs. 66A-66C** depict various configurations of an exemplary therapeutic device.

[0105] **FIG. 67** shows an illustrative embodiment of a pre-set heat formed therapeutic device in cross section through a longitudinal axis.

[0106] **FIGs. 68A-68B** show a therapeutic device with a single rib of material affixed to or formed on the device.

[0107] **FIGs. 69A-69D** show a therapeutic device with multiple ribs of material affixed to or formed on the device.

[0108] **FIGs. 70A-70C** illustratively show means that may be attached to the anchor band or anchor band delivery tool for providing perceptible feedback.

[0109] **FIG. 71A-71G** depict illustrative means for latching, locking or otherwise securing the treatment device in its final configuration.

[0110] **FIGs. 72A-72B** show a treatment device constructed of two bodies.

[0111] **FIGs. 73A-73C** show an illustrative example of multiple members forming inner and outer members of a treatment device.

[0112] **FIGs. 74A-74B** show alternative illustrative mechanisms of drawing together locking elements/anchors.

[0113] **FIGs. 75A-75B** show alternative illustrative attachment mechanisms where a pledget element that initially resides on outer annular surface.

[0114] **FIGs. 76A-76B** show a cross section view of the delivery of a flowable material from the distal end of delivery device.

[0115] **FIG. 77** illustrates an alternative method and device for the introduction of material into the disc space via the fixation element delivery tool.

[0116] **FIGs. 78A-78B** depicts an anchor band assembly used to repair a circumferential tear in the annulus.

[0117] **FIG 79A-79B** illustrate illustrative embodiments of the invention used to treat meniscal tissue of the knee.

[0118] **FIGs. 80A-80B** illustrate an illustrative general surgical application of the invention for treating hernia.

Detailed Description of Illustrative Embodiments of the Invention

[0119] Reference will now be made in detail to selected illustrative embodiments of the invention, with occasional reference to the accompanying drawings. Wherever possible, the same reference numbers will be used throughout the drawings to refer to the same or like parts.

[0120] In the surgical repair of an aperture in the annulus, as shown in FIG. 1 and as described in related commonly-assigned U.S. Patent 6,592,625 to Cauthen, a damaged annulus **42** is repaired by use of surgical sutures **40**. One or more surgical sutures **40** are placed at about equal distances along the sides of a pathologic aperture **44** in the annulus **42**. Reapproximation or closure of the aperture **44** is accomplished by tying the sutures **40** so that the sides of the aperture **44** are drawn together. The reapproximation or closure of the aperture **44** enhances the natural healing and subsequent reconstruction by the natural tissue (e.g., fibroblasts) crossing the now surgically narrowed gap in the annulus **42**. Preferably, the surgical sutures **40** are biodegradable, but permanent non-biodegradable may be utilized. In all embodiments where biodegradable materials are indicated, suitable biodegradable materials may include, but are not limited to, biodegradable polyglycolic acid, swine submucosal intestine, collagen, or polylactic acid. Other suitable suturing (and band) materials include, e.g., polymeric materials such as polyethylene terephthalate (PET), polyester (e.g., Dacron™), polypropylene, polyethylene, polycarbonate urethane or metallic material include, e.g., titanium, nickel titanium alloy, stainless steel, surgical steels or any combinations thereof.

[0121] Additionally, to repair a weakened or thinned wall of a disc annulus **42**, a surgical incision or dissection can be made along the weakened or thinned region of the annulus **42** and one or more surgical sutures **40** can be placed at about equal distances laterally from the incision. Reapproximation or closure of the incision is accomplished by tying the sutures **40** so that the sides of the incision are drawn together. The reapproximation or closure of the incision/dissection enhances the natural healing and subsequent reconstruction by the natural tissue crossing the now surgically narrowed gap in the annulus **42**.

Preferably, the surgical sutures **40** are biodegradable, but permanent non-biodegradable materials may be utilized.

[0122] Where necessary or desirable, the method can be augmented by placing a patch in and across the aperture **44**. The patch acts as a bridge in and across the aperture **44**, providing a platform for traverse of fibroblasts or other normal cells of repair existing in and around the various layers of the disc annulus **42**, prior to closure of the aperture **44**. FIGs. 2A-B, for example, show a biocompatible device employed as an annulus stent **10**, being placed in and across the aperture **44**. The annulus stent **10** acts as a bridge in and across the aperture **44**, providing a platform for a traverse of fibroblasts or other normal cells of repair existing in and around the various layers of the disc annulus **42**, prior to closure of the aperture **44**. In some embodiments the device, stent or patch can act as a scaffold to assist in tissue growth that healingly scars the annulus.

[0123] In an illustrative embodiment, the annulus stent **10** is a solid unit, formed from one or more of the flexible resilient biocompatible or bioresorbable materials well known in the art. The selection of appropriate stent materials may be partially predicated on specific stent construction and the relative properties of the material such that, after fixed placement of the stent, the repair may act to enhance the healing process at the aperture by relatively stabilizing the tissue and reducing movement of the tissue surrounding the aperture.

[0124] For example, the annulus stent **10** may be made from:

[0125] A porous matrix or mesh of biocompatible and bioresorbable fibers acting as a scaffold to regenerate disc tissue and replace annulus fibrosus as disclosed in, for example, U. S. Patent Nos. 5,108,438 (Stone) and 5,258,043 (Stone), a strong network of inert fibers intermingled with a bioresorbable (or bioabsorbable) material which attracts tissue ingrowth as disclosed in, for example, U.S. Patent No, 4,904,260 (Ray et al.).

[0126] a biodegradable substrate as disclosed in, for example, U.S. Patent No. 5,964,807 (Gan et al.); or

[0127] an expandable polytetrafluoroethylene (ePTFE), as used for conventional vascular grafts, such as those sold by W.L. Gore and Associates,

Inc. under the trademarks GORE-TEX and PRECLUDE, or by Impra, Inc. under the trademark IMPRA.

[0128] Furthermore, the annulus, stent **10**, may contain hygroscopic material for a controlled limited expansion of the annulus stent **10** to fill the evacuated disc space cavity.

[0129] Additionally, the annulus stent **10** may comprise materials to facilitate regeneration of disc tissue, such as bioactive silica-based materials that assist in regeneration of disc tissue as disclosed in U.S. Patent No. 5,849,331 (Ducheyne, et al.), or other tissue growth factors well known in the art.

[0130] Many of the materials disclosed and described above represent embodiments where the device actively promotes the healing process. It is also possible that the selection of alternative materials or treatments may modulate the role in the healing process, and thus promote or prevent healing as may be required. It is also contemplated that these modulating factors could be applied to material substrates of the device as a coating, or similar covering, to evoke a different tissue response than the substrate without the coating.

[0131] Materials of the patch could include a metallic material (e.g., NiTi alloy, Stainless steel, Titanium), or a polymeric material (e.g., polypropylene, polyethylene, polyurethane, polycarbonate urethane, Polyetheretherketone (PEEK), polyester, PET, poly olefin copolymer, polypropylene, polyethylene), or a biodegradable or bioresorbable material (e.g., collagen, cellulose, polysaccharide, polyglycolic acid (PGA), a polylevolactic acid (PPLA), a polydioxanone (PDA) or for example a racemic polylactic acid (PDLLA), or a combination of these materials.

[0132] In an illustrative method of use, as shown in FIGs. 3A-3D, lateral extensions **20** and **22** of a stent **10** are compressed together for insertion into the aperture **44** of the disc annulus **42**. The annulus stent **10** is then inserted into the aperture **44**, where the lateral extensions **20**, **22** expand. In an expanded configuration, the upper surface **28** can substantially conform to the contour of the inside surface of the disc annulus **42**. The upper section **14** is positioned within

the aperture **44** so that the annulus stent **10** may be secured to the disc annulus **42**, using means well known in the art.

[0133] In an alternative method, where the length of the aperture **44** is less than the length of the outside edge **26** of the annulus stent **10**, the annulus stent **10** can be inserted laterally into the aperture **44**. The lateral extensions **20** and **22** are compressed, and the annulus stent **10** can then be laterally inserted into the aperture **44**. The annulus stent **10** can then be rotated inside the disc annulus **42**, such that the upper section **14** can be held back through the aperture **44**. The lateral extensions **20** and **22** are then allowed to expand, with the upper surface **28** contouring to the inside surface of the disc annulus **42**. The upper section **14** can be positioned within, or proximate to, the aperture **44** in the subannular space such that the annulus stent **10** may be secured to the disc annulus, using means well known in the art.

[0134] It is anticipated that fibroblasts will engage the fibers of the polymer or fabric of the intervertebral disc stent **10**, forming a strong wall duplicating the currently existing condition of healing seen in the normal reparative process.

[0135] In an alternative embodiment, as shown in FIG. 4A, the annulus stent **10** is substantially umbrella shaped, having a central hub **66** with radially extending struts **67**. Each of the struts **67** is joined to the adjacent struts **67** by a webbing material **65**, forming a radial extension **76** about the central hub **66**. The radial extension **76** has an upper surface **68** and a lower surface **70**, where the upper surface **68** contours to the shape of the disc annulus' **42** inner wall when inserted as shown in FIG. 6A-6C, and where the lower surface **70** contours to the shape of the disc annulus' **42** inner wall when inserted as shown in FIG. 5A-5C. The radial extension **76** may be substantially circular, elliptical, or rectangular in plan shape.

[0136] As shown in FIGs. 4B and 4C, the struts **67** are formed from flexible material, allowing the radial extension **76** to be collapsed for insertion into aperture **44**, then the expand conforming to the shape of the inner wall of disc annulus **42**. In the collapsed position, the annulus stent **10** is substantially

frustoconical or shuttlecock shaped, and having a first end **72**, comprising the central hub **66**, and a second end **74**.

[0137] In an alternative embodiment, the radial extension **76** has a greater thickness at the central hub **66** edge than at the outside edge.

[0138] In a method of use, as shown in FIGs. 5A-5C, the radial extension **76** is collapsed together, for insertion into the aperture **44** of the disc annulus **42**. The radial extension **76** is folded such the upper surface **68** forms the outer surface of the cylinder. The annulus stent **10** is then inserted into the aperture **44**, inserting the leading end **72** through the aperture **44** until the entire annulus stent **10** is within the disc annulus **42**. The radial extension **76** is released, expanding within the disc **44**. The lower surface **70** of the annulus stent **10** contours to the inner wall of disc annulus **42**. The central hub **66** is positioned within the aperture **44** so that the annulus stent **10** may be secured to the disc annulus **42** using means well known in the art.

[0139] It is anticipated that fibroblasts will engage the fibers of the polymer or fabric of the annulus stent **10**, forming a strong wall duplicating the currently existing condition of healing seen in the normal reparative process.

[0140] In an alternative method of use, as shown in FIGs. 6A-6C, the radial extension **76** is collapsed together for insertion into the aperture **44** of the disc annulus **42**. The radial extension **76** is folded such that the upper surface **68** forms the outer surface of the stent, for example in a frustoconical configuration as illustrated. The annulus stent **10** is then inserted into the aperture **44**, inserting the tail end **74** through the aperture **44** until the entire annulus stent **10** is in the disc. The radial extension **76** is released, expanding within the disc. The upper surface **68** of the annulus stent **10** contours to the disc annulus' **42** inner wall. The central hub **66** is positioned within the aperture **44** so that the annulus stent **10** may be secured to the disc annulus **42**, using means well known in the art.

[0141] In one illustrative embodiment, the barbs **82** on the upper surface **68** of one or more strut **67** or other feature of the radial extension **76**, engage the disc annulus' **42** inner wall, holding the annulus stent **10** in position.

[0142] FIG. 7 shows a further aspect of the present invention. According to a further illustrative embodiment, a simplified schematic cross section of a vertebral pair is depicted including an upper vertebral body **110**, a lower vertebral body **112** and an intervertebral disc **114**. An aperture or rent **116** in the annulus fibrosus (AF) is approached by a tube **118**, which is used to deliver a device **120** according to a further aspect of the present invention. The device **120** may be captured by a delivery tool **122** through the use of a ring or other fixation feature **124** mounted on the repair device **120**.

[0143] FIG. 8 shows a delivery method similar to that depicted in FIG. 7, with the exception that the tube **118A** has a reduced diameter so that it may enter into the sub-annular space of the disc **114** through the aperture or rent.

[0144] Turning to FIGs. 9A-9C, according to a further aspect of the present invention, the delivery of the device **120** through the delivery tube **118** or **118A** may be facilitated by folding the arms or lateral extensions **128**, **130** of the device to fit within the lumen of the tube **118** or **118A** so that the stent or device **120** is introduced in a collapsed configuration. The device **120** is moved through the lumen of the tubes **118** or **118A** through the use of delivery tool **122**. FIG. 9B shows the arms deflected in a distal, or forward direction for insertion into the delivery tube **118** or **118A** while FIG. 9A shows the arms **128**, **130** deflected into a proximal position. FIG. 9C shows the device **120** curled so that one arm **128** is projecting distally, or in a forward direction, and the other arm **130** is projecting proximally, or in a rearward direction. Because the lateral extent of the device is relatively flexible, whether the device is of natural or synthetic material, other collapsible configurations consistent with the intent of this invention are also possible, including twisting, balling, crushing, folding, bending, etc.

[0145] FIG. 10A shows an alternative fixation strategy where a pair of barbs **134** and **136** are plunged into the annulus fibrosus from the exterior of the annulus while the device **120** is retained in the sub-annular space by means of a tether **142**. Although there are a wide variety of fixation devices in this particular example, a tether **142** may be knotted **145** with the band **144** holding the barbs **134** and **136** together to fix the device in the sub-annular space. The knot is

shown in an uncinched position to clarify the relationship between the tether **142** and the bands **144**. Using this approach, the device can be maintained in a subannular position by the barbed bands while the tether knot is cinched, advantageously simultaneously reapproximating the annulus to close the aperture while drawing the device into sealing, bridging engagement with the subannular wall of the annulus fibrosus.

[0146] FIG. 10B shows an alternative fixation strategy where the barbs **148** and **150** are sufficiently long that they can pierce the body of the device **120** and extend all the way through the annulus fibrosus into the device **120**. In this configuration, the band **144** connecting the barbs **148** and **150** may be tightened to gently restrain and position the device **120** in the sub-annular space, or tightened with greater force to reapproximate the aperture or rent.

[0147] Patches can be folded and expanded in a single plane or in three dimensions. As shown in FIGs. 9A-9C for example, collapsing the patch can be accomplished laterally, whether the device is a single material or composite. Others can collapse in three dimensions, such as those shown in FIGs. 4, 5, 27, 30 and 34. Devices which expand in three dimensions can optionally be packaged in a restraining sheath, jacket, gelatin shell or "gelcap", or a mesh of biosorbable or dissolvable material, that would allow for facile placement and subsequent expansion.

[0148] It is understood that there can be a variety of device designs of patches/stents/meshes/devices/treatment devices to accomplish the expansion of a device from a first configuration, to a second configuration to occupy at least a portion of the sub-annular space and reduce re-extrusion of the nucleus, or otherwise facilitate maintaining other intradiscal materials within the disc space. These devices can be constructed of single components or multiple components, with a variety of different materials, whether synthetic, naturally occurring, recombinated (genetically engineered) to achieve various objectives in the delivery, deployment and fixation of a device to repair or reconstruct the annulus. The following device concepts are further discussed for additional embodiments of a device and/or system for the repair of an intervertebral disc annulus. The

following descriptions will illustratively depict and describe methods, devices, and tools to deliver a treatment to an intervertebral disc after a lumbar discectomy procedure; although, it is anticipated that these methods, devices, and tools may be similarly used in a variety of applications. As an example, the embodiments described herein may also advantageously maintain materials within the disc space other than natural disc tissue (nucleus, annulus, cartilage, etc.), such as implants and materials that may be used to replace and/or augment the nucleus pulposus or other parts of disc's tissues. These procedures may be performed to treat, for example, degenerative disc disease. Whether these materials are intended to replace the natural functioning of the nucleus pulposus (i.e., implantable prosthetics or injectable, in-situ curable polymer protein, or the like) or provide a fusion between vertebral bodies (i.e., implantable bony or synthetic prosthetics with materials to facilitate fusion, such as growth factors like bone morphogenic proteins) one skilled in the art would realize that variations to the embodiments described herein may be employed to better address characteristic differences in the various materials and/or implants that could be placed within the subannular space, and that these variations would be within the scope of the invention.

[0149] Furthermore, it should be noted that surgeons differ in their techniques and methods in performing an intervention on a spinal disc, and the inventive descriptions and depictions of methods, devices and delivery tools to repair annular tissue could be employed with a variety of surgical techniques; such as, but not limited to: open surgical, microsurgical discectomy (using a magnifying scope or loupes), minimally invasive surgical (through, for example, a METRx™ system available from Medtronic, Inc.), and percutaneous access. Surgeons may also employ a variety of techniques for intra-operative assessment and/or visualization of the procedure, which may include: intra-operative probing, radiography (e.g., C-arm, flat plate), and endoscopy. It is contemplated that the inventive embodiments described are not limited by the various techniques that may be employed by the surgeon.

[0150] In addition, the surgical approach to the intervertebral disc throughout the figures and descriptions depict a common approach, with related structures, to a lumbar discectomy; although, it is possible that surgeons may prefer alternative approaches to the intervertebral disc for various applications (for example, different intervertebral disc levels such as the cervical or thoracic region, or for nucleus augmentation), which may include, but is not limited to: posterior-lateral, anterior, anterior-lateral, transforaminal, extra-foraminal, extra-pedicular, axial (i.e., through the vertebral bodies), retroperitoneal, trans psoas (through the Psoas muscle), contralateral. The approach to the intervertebral disc space should not be interpreted to limit the use of the invention for the repair or reconstruction of the an aperture, weakened or thin portion of the annulus, as described herein.

[0151] It is also important to note that the boundary in the intervertebral disc space between the annulus fibrosus and the nucleus pulposus as depicted herein may be demarked or otherwise highlighted; however, it is important to recognize that these tissues are not as precisely demarked in human tissues, and may be even less so as the patient ages or evinces degeneration of the intervertebral disc. This demarcation may be especially difficult to discern during an operative procedure, using for example; available surgical tools (i.e., probes), fluoroscopic guidance (x-ray), or visual (endoscope) guidance. However, in general, the layers of the annulus have more structural integrity (and strength) than the nucleus, and this integrity varies from the outer most layers of the annulus being of higher structural integrity than the inner most layers of the annulus.

[0152] Moreover, the drawings and descriptions herein are necessarily simplified to depict the operation of the devices and illustrate various steps in the method. In use, the tissues may be manipulated by, and are frequently in contact with, the various tools and devices; however, for clarity of construction and operation, the figures may not show intimate contact between the tissues the tools and the devices.

[0153] As depicted in FIG. 11A, a herniated disc occurs when disc nucleus material emerges from the subannular region and outside of the disc. Herniated disc nucleus material then impinges on nerve tissue, causing pain. A discectomy attempts to relieve pressure on the nerve tissue through surgical removal of disc material, the result usually being an aperture in the disc annulus wall, and usually a void in the subannular space where disc nucleus was removed, as shown in FIG. 11B. Figure 11B typifies a disc after the discectomy procedure has been performed, as do most of the drawings and descriptions contained herein. However, it should be understood that in order to perform a discectomy procedure, there are a variety of instruments and tools readily available to the surgeon during spine surgery, or other surgical procedures, to obtain the outcome as shown in Fig. 11, or other outcomes intended by the surgeon and the surgical procedure. These tools and instruments may be used to: incise, resect, dissect, remove, manipulate, elevate, retract, probe, cut, curette, measure or otherwise effect a surgical outcome. Tools and instruments that may be used to perform these functions may include: scalpels, Cobb elevators, Kerrison punch, various elevators (straight, angled, for example a Penfield), nerve probe hook, nerve retractor, curettes (angled, straight, ringed), rongeurs (straight or angulated, for example a Peapod), forceps, needle holders, nerve root retractors, scissors. This list is illustrative, but is not intended to be exhaustive or interpreted as limiting. It is anticipated that some of these tools and/or instruments could be used before, during, or after the use of the inventive methods, devices and tools described herein in order to access, probe (e.g., Penfield elevator), prepare (e.g., angled or ringed curette, rongeur, forceps), and/or generally assess (e.g., angled probe) treatment site or facilitate the manipulation (e.g., forceps, needle holder), introduction (e.g., forceps, needle holder, angled probe), or deployment (e.g., forceps, needle holder, angled probe) of the treatment device and/or its components.

[0154] There are a variety of ways to affix a device to the sub-annular wall of the annulus in addition to those discussed hereinabove. The following exemplary embodiments are introduced here to provide inventive illustrations of the types of

techniques that can be employed to reduce the time and skill required to affix the patch to the annulus, versus suturing and tying a knot. Discussed hereinabove is the use of sutures, staples and other fixation devices to affix the patch to the annulus. In a simple example, a patch/stent could be compressed, passed through a guide tube such as tubes **18**, **18A** shown in FIGs. 7 and 8, and expanded within the sub-annular space.

[0155] Another fixation means includes the passing of "anchoring bands" into the wall of the annulus, vertebral bodies (superior, inferior, or both), or the Sharpey's Fibers (collagenous fibers between the junction of the annular fibers and vertebral bodies). In the following example of anchors, the barbs or bands are affixed to the annulus/vertebral bodies/Sharpey's fibers. Another element, for example a suture, cinch line, or a staple is utilized to attach the anchor bands to the patch, and thus hold the patch in proximity to the inner wall of the annulus. In addition, these bands may re-approximate the tissues at the aperture.

[0156] Another example of fixating the device to inner wall of the annulus is further illustrated by FIGs 12-14. As discussed hereinabove, with reference to FIGs. 7-10, a patch **120** is placed with a delivery tool **122**, through the inner lumen of a guide tube **118**, into the sub-annular space and then expanded. This step can also be seen in FIGs. 13 and 14, where a patch **702** is folded and passed through a guide tube **706** and is held by a delivery tool **704**. Also shown is a anchor band or staple **709** and an anchor band delivery device **708**. Within the guide tube, or within the delivery tool, there is a suture line or cinch line **710** that is attached to the center of the patch **702**. This can be seen in FIG. 12A with the guide tube **706** removed. As seen in FIGs. 13C and 14A, the guide tube **706** is retracted after the patch **702** has been expanded and deployed. Next, as shown in FIGs. 12 and 14, an anchor band delivery tool **708** is used to deliver one or more "bands" **709** onto the outer surface of the annulus. These are intended to be anchored into the wall of the annulus with barb shapes that do not allow for the barbs to be pulled back through the annulus. The anchor bands resemble a construction of a "staple". The bands could actually be constructed by connecting

two barbed elements with, for example, a suture between the two barbed elements.

[0157] The barbs and the connection band between the barbs could be constructed of the same material or of different materials. For example, the barbed part of the anchor band could be a biodegradable/bioabsorbable material (such as, for example, collagen, cellulose, polysaccharides, carbohydrates, polyglycolic acid, polylevolactic acid, polydioxanone, racemic polylactic acid) or could be constructed of a metallic or polymeric biocompatible material (e.g., titanium, NiTi alloy, stainless steel, platinum, gold, polyurethane, polycarbonate urethane, polyimide, polyamide, polypropylene, polyethylene, polypropylene, polyester, PET, PEEK). The anchors could also be constructed of a combination of these materials. In addition, the band that connects these barbs can be constructed of materials that are similar to the barbs, or different materials. For example, the connection band could be a biodegradable/bioabsorbable suture, such as Vicryl, or a biocompatible material such as polypropylene, polyethylene, silk, stainless steel, PET. In addition, it is possible that these elements are constructed from multiple materials to accomplish the objective of anchoring into the annulus and providing for a fixation site to draw the tissues together.

[0158] FIGs. 12B and 12C show the placement of the anchor bands **709** into the annulus **712** with the anchor band delivery tool **708**. FIGs. 14A and 14B schematically show the placement of the anchor bands **709** into the wall of the annulus **712** and the retraction of the anchor band delivery device **708**, with the patch delivery tool **704** still in place. FIG. 12D depicts a representative anchor band **709**, having a pair of stainless steel barbs **709'** connected by a suture **709'**. FIG. 12E shows the patch **702**, anchor bands **709**, and cinch line or suture **710** with the delivery tools removed, prior to drawing the patch and the tissues of the annulus together. In this embodiment there is a pre-fabricated slip knot **714** on the cinch line, although other locking elements or knots are possible. Suture loops can connect to the barbs directly, as in FIG. 12, or loop to surgical staples, or are placed directly into the annulus. The presence of a pre-fabricated knot on the cinch line makes the process of repairing quicker since there is no need to tie

a knot. It also facilitates drawing the tissues together. The use of the cinch line and a pre-fabricated knot can be placed by, for example, an external tube such as a knot pusher. FIG. 12E is similar to FIG. 10 described hereinabove prior to "tying" the knot **714**. FIG. 12F shows the drawing of the patch and the annular tissues together by pulling on the suture in the direction "A" indicated by the arrow. In this case, the Knot Pusher has been removed from the cinch line **710**. The suture **710** is drawn proximally to draw the patch **702** into engagement with the inner wall of the annulus to seal the aperture from within, as well as draw the walls of the annulus together to reapproximate the annular aperture. FIG. 14C and FIG. 12G show the cinch line suture **710** tied and drawing the annular tissues together, after the excess suture line has been cut. It is also apparent from this device, fixation and delivery system that the outer surfaces of the aperture may be drawn together for re-approximation.

[0159] The cinching of the anchor bands and the patch also allows for taking-up the slack that allows for the accommodation of varying sizes. For example, the thickness of the annular wall surrounding the aperture can vary from 1 mm up to 10 mm. Therefore, if the anchor bands have a set length, this design with a cinch line accommodates different dimensions of the thickness of the wall of the annulus by drawing the "slack" of the bands together within the aperture.

[0160] Although it has been described here as patch placement that involves two lateral anchor bands with a suture to draw the patch, bands and tissues together, one or two or more bands could be used and two bands is only an example. Furthermore, the anchor bands were placed with the barbs in a superior-inferior fashion. One skilled in the art would recognize that these could be placed at different locations surrounding the aperture, vertebral bodies or into the Sharpey's fibers

[0161] Although the patch depicted in the example above does not have barbs attached to the patch, it is also possible to have the barbs as described hereinabove to further promote the fixation of the patch to the inner wall of the annulus.

[0162] Finally, although the drawings depict an aperture that lends itself to re-approximating the tissues, it is conceivable that some apertures, whether natural or surgically made, may be relatively large and therefore might require the placement of additional material within the aperture to act as a scaffold for tissue in growth, between the patch on the inner wall of the annulus and the anchor bands located on the outer wall. An example of material to fill the aperture might include autograft para-spinal fascial tissue, xenograft, allograft, or other natural collagenous materials. The filler material could also be of a biocompatible material such as a Dacron (polyester, or PET), polypropylene, polyethylene material. FIG. 17 shows the illustrative filling of an aperture with implant material **716** prior to cinching the suture **710**.

[0163] As an alternative embodiment of the present invention, the anchor bands **709** as described previously (anchor bands into annulus) could be sufficiently long enough to pass through the annulus and then through the patch. The barbs in this embodiment have an engaging involvement with the patch. This concept was previously discussed hereinabove in connection with FIG 10. Further illustration of such a system is schematically shown in FIGs. 15 and 16. Passing the barbs through the patch, in this embodiment, provides additional security and safety by reducing the possibility that the barbs may migrate after implantation. In this application of the invention, the suture cinch line may (FIG. 16C) or may not (FIG. 10B) be used in addition to the anchor bands to draw the tissues together and reduce tissue movement surrounding the aperture.

[0164] In addition, although the bands shown in FIG. 12 through 16 take the form of a "barb", they could as easily take a form of a simple T-barb **720**, as shown in FIG. 18E, or a C- type element wherein the object is to have irrevocable engagement with the patch device **702** after the penetration through the patch. A T-type attachment, when aligned longitudinally with the suture, passes through the patch. The T section then rotates to prevent the suture anchor from being pulled back through the patch. In another embodiment a "C" retainer made of a superelastic material may be attached to the end of the suture band. The C retainer is loaded into a needle wherein it is held straight. The needle is used to

pass the C retainer and suture through the patch and deploy the retainer in a second configuration in the shape of a "C".

[0165] It is also foreseen within the scope of the invention that there may be patch designs which will accommodate the placement and securement of the anchor to the fabric that covers the frame of the patch. For example, a frame for a patch that is made out of metal such as Nitinol can provide for "windows". The device, covered with a mesh fabric, for example silicone or Dacron, would therefore allow the anchoring barbs to be passed through the "windows" in the frame of the patch. In this case, the barb can be secured to the patch in the fabric covering the frame.

[0166] Alternatively, the patch can be secured by passing barbs that engage the lattice of the patch frame. These embodiments of the invention illustrate designs in which the barbs engage with the vertical, horizontal or criss-crossed structures/members of the frame. In this case, the barbs would pass through the mesh or lattice of the frame and they would be unable to pass back out of the structure.

[0167] Although this discussion refers to "anchor bands" that are shown to be two anchors connected by a suture, it is also contemplated that single barbs with sutures could be placed and the sutures' ends, at the outer surface of the annulus, are tied after placement through the patch. It is also possible that these "single anchors" could be retained by a suture "pledget" on the outer wall of the annulus to better hold the outer surface, or could include a suture (or band) locking device.

[0168] One objective in the designs discussed hereinabove is to provide a way to "pull up the slack" in a system to adjust the length of sutures and for anchor bands. According to the present invention, a technique referred to as the "Lasso Cinch Knot" was developed as a means to draw the anchor bands together with a suture cinch line that is incorporated into the patch design. FIG. 19 gives further description of the use of the Lasso embodiment. In essence, patch and frame constructs are used that incorporate the "barbs through the patch" design. Once the barbs have passed through the patch, an internal lasso

722 is drawn tight around the sutures of the anchor bands and thus draws the extra suture material within the patch. The internal lasso gathers the sutures of the bands, and as the lasso is tightened, it cinches together the sutures of the bands and therefore tightens them and eliminates slack, bringing the patch/stent into closer or tighter engagement with the annulus wall. The patch in FIG. 19 additionally provides for a diamond shape grid pattern, which advantageously provides a grid which will while allowing a probe or similar instrument to pass through with little resistance, provides resistance to a barb or other restraining feature on the instrument. The frame shown can be made from nitinol, and the locking and holding windows shown at the center of the FIG. 19 would allow for rotation about the z-axis during placement. A slipknot technique using, for example a knot pusher, would aid in the loop pulling process by the lasso. The internal loop (lasso) can be tacked to the outside corners of the patch/stent, in order to hold the loop at the outer edges of the patch frame. When cinching the lasso knot, the loop can be pulled free from some or all of its tacked attachment points to the frame, to prevent deformation of the planar shape of the frame when cinching the lasso. As above, the frame can be a composite structure or sandwich formed with some type of mesh fabric. The proximal mesh fabric can be bonded fully to the patch frame, for example through the use of an adhesive, for instance a silicone. Adhesive, advantageously, can fill the interstices of the grid pattern while allowing for easy probe penetration and protection of the suture lines. Protection of the suture lines is advantageous when the lasso is used to pull and bunch a group of band sutures together.

[0169] It is also contemplated within the scope of the present invention that sutures or bands **710'** can be preattached directly to a stent/patch. As shown in FIG. 18A several separate barbs **709''** into the annulus **712** can be directly attached to the patch **702**. Each "barb" of FIG. 18A can be independently placed into the annulus after the patch is deployed.

[0170] An alternative embodiment for securing a patch **902** and reapproximating a rent or incision is to provide each of the separate barbs with sutures having variable lengths as shown in FIG. 20. Each independent suture

barb **904** is placed into the annulus **906** or into the patch **902** with the barb delivery tool **908**. After the placement, all of the suture lines **910** are drawn taught, by drawing on the free ends that exit the patch delivery tool **912**. A locking element (which may be referred to as a locking clamp, or band locking device, or band retention device) **914** that uses a gasket **915** and threading mechanism within is attached to the patch **902** and is used to tighten the gasket **915** around the distal ends of the sutures **910**. The patch delivery tool **912** is removed and the extra suture length is cut. It is also possible that the gasket mechanism could be a press-fit to accommodate the tightening of the sutures to the patch.

[0171] Alternatively, the locking mechanism can be as shown in FIG. 21, although in this case the engagement of the locking element **914'** takes part on the anchor. Pulling the tether **910** in the direction of arrow **B** will tighten and lockingly hold in tension to aid in securement and tissue approximation. The adjustable length band between the two anchors allows slack to be taken up between the anchors **916**. Two T-type anchors are illustratively shown in this example, but multiple anchors of differing configurations could be used. The locking features can be included on the feature band, as depicted here, and allow for substantially one-way locking engagement with the anchor members. This adjustability advantageously promotes for the accommodation of varying thickness of the annulus from patient to patient. The suture/band slack in this embodiment may be taken up to close the defect in the annulus and/or to shorten the band between anchors for a secondary cinching of multiple tensioned suture bands as described herein.

[0172] Fig. 22 shows alternative embodiments for tightening "anchoring barbs" with different configurations of sutures and cinch lines. For example in Fig. 58B each independent barb has a looped suture attached to it. Through each of these loops is passed a cinch line, which contains a knot. After placement of the barbs within the annulus, and possibly through the patch, the cinch line draws the loops of the barbs together. The advantage of this embodiment is that it allows for the independent placement of multiple barbs and the ability to draw all of them together.

[0173] Although cinch lines have been described as using a knot to "lock" the length of the suture, other mechanisms could also lock the length, as shown in Figure 21. The locking of the suture length is accomplished through a mechanical element located on the barb which engages with three dimensional elements attached to the suture line which mechanically press fit through the engagement element on the barb, thus locking the length of the suture line into place.

[0174] Although the embodiments of Fig. 21 and Fig. 22 depict the use of a single locking mechanism (e.g., knot on cinch line), it is conceivable that various designs could use more than one locking element to achieve the re-approximation and drawing together the tissue surrounding an aperture.

[0175] Similarly, an alternative embodiment to cause tension within the device and draw the tissues together after placement of the anchor bands might include an elastic band or band with a spring which one end can be attached to the anchor bands and the other end attached to the patch. Alternatively, the anchor bands might, in and of themselves may be made of an elastic band between the barbs, or may contain a spring element between the barbs. Such an embodiment can be made to resemble a so-called "Bobber Spring." Again, it is contemplated that the elastic or resilient element could be made from a wide variety of metals, polymeric, or biodegradable/bioabsorbable material.

[0176] As previously mentioned, the present invention also encompasses delivery devices or tools of the following description. The delivery devices of the present invention are configured to deliver at least one, or a portion thereof, device into (or through) the annulus or other surface or tissue. The delivery tools (or devices) will typically comprise devices or shafts having proximal and distal ends. As referred to herein, the proximal portion of a device or tool or component will generally refer to the portion of the device/tool/component that is located furthest away from the patient (and closest to the surgeon); whereas, the distal portion will generally refer to the portion that is within (in use), or closest to the patient (and therefore furthest away from the surgeon). Although some of the device descriptions may refer to some fixation element embodiments as being

“fixation” or “anchor/anchor band/barb”, this is done for clarity reasons and should not be misconstrued to suggest that the device is not capable of also performing a treatment and/or a repair.

[0177] In addition, the following descriptions of delivery devices/tools are generally intended to be single-use and disposable; however, it is clear that these tools could as easily be constructed to be partially, or wholly, re-usable and re-sterilizable.

[0178] An illustrative delivery device as depicted in FIGs. 24-26 may be configured to accommodate and deploy at least one fixation device, such as a barb or T-anchor with one or more associated bands. Advantageously, the distal end of the delivery device will comprise a hollow needle or cannula **711**, having a circular, elliptical, triangular, hexagonal or other inner cross sectional area, suitable to accommodate the cross-sectional shape of the fixation device within. The distal point of the cannula **711** is advantageously sharpened, as a needle, to accommodate insertion. The cannula **711** is advantageously cut obliquely as shown in FIG. 26 to form a sharp leading surface or point for ease of insertion. The cannula **711** may contain a cut or groove **718** along its side to accommodate one or more anchors **709** as shown (or barbs, not shown), e.g., in FIGs. 24B or 26. In one embodiment, the at least one fixation device (including band and barb or T-anchor), or portion thereof, is disposed within the cannula **711** as shown in FIGs. 24a, 24b, and/or 26. Alternatively, the T-anchor **709** (or barb, not shown), or other fixation device may be hollow and disposed in a manner surrounding the device of the delivery device.

[0179] The delivery device **708** will also advantageously contain within it an ejection rod **715**. The proximal end of the ejection rod **715** typically will contain an end portion **713** to function as a stopper, e.g., having a diameter larger than the remaining portion of the rod, such as is shown in FIG. 24a. The diameter of the remaining portion of the ejection rod **715** will be small enough for insertion within the shaft of the device **708**. Upon insertion of the cannula **711** into the location of choice, the ejection rod is pushed to deliver the fixation device. The delivery device is then removed.

[0180] Advantageously, the ejection rod **715** and delivery device may be configured to deliver multiple fixation devices, sequentially or simultaneously. Thus, if multiple fixation devices are contained within the device, the ejection rod **715** and delivery device may be configured such that the rod **715** be pushed a first distance, sufficient to deliver a first fixation device. The device is then removed from the first insertion point and inserted into a second insertion point, where the ejection rod is then pushed a second distance for delivery of a second fixation device, and so-on as desired. For simultaneous delivery of multiple fixation devices, multiple delivery devices may be arranged in parallel (or substantially parallel). The distance between (or among) the delivery devices may be fixed or adjustable, as desired.

[0181] The distance the ejection rod **715** is pushed to define a first, second, and subsequent distances may be regulated by feel. Alternatively, the distance can be regulated by the architecture of the device. For example, the shaft and ejection rod may be fitted with a notch-and-groove configuration, respectively. In such configuration, the notch in the outer surface of the ejection rod may be aligned with a groove in the inner surface of the device. The length of the groove defines a first distance. The ejection rod **715** would be then turned or rotated within the device, aligning the notch within the device to a second groove defining a second distance, and so-on. In an alternative embodiment, the ejection rod and anchor portion of the fixation device (e.g., barb or T-anchor) may surround the shaft of the device, as a sleeve surrounds an arm. In such a configuration, the delivery tool would comprise a solid shaft and the ejection rod and fixation device would be at least partially hollow and disposed over the distal portion of the delivery device. Pushing the ejection rod in a proximal to distal direction would deploy the anchor portion of the fixation device.

[0182] FIGs. 24A and 24B describe one embodiment of an anchor band delivery device **708** and fixation means. FIG. 24A shows a general drawing of a delivery device. FIG. 24b further depicts the distal end of the delivery device. Anchor band delivery device **708** contains two pointed needles or cannulas **711**. Each cannula **711** contains an anchoring T-type anchor **709** (or barb) positioned

within the distal end of the cannula **711**. A band **709'** links the two anchors **709** (or barbs) together and a cinch knot **714** secures the anchors (or barbs). Cinch line **710** is pulled to decrease the length of the band **709'** that attaches the anchors **709**.

[0183] Referring to FIG. 25A, anchor band delivery device **708** is inserted into the annulus **712** sufficiently to engage the inner layers of the annulus **712**, and preferably located at the inner wall of the annulus **712**. The anchors **709** are ejected from the delivery device by pressing the ejection rod **715** in a fashion to expel the T-anchors **709** (or barbs, not shown) from the device. For example, pressing on the proximal end of ejection rod **715** as shown in FIG. 24A drives the ejection rod **715** in a distal direction, thus expelling the anchor from the device. FIG. 25B shows the anchors **709** (or barbs) after being ejected. FIG. 25C shows a knot pusher **716** attached to the delivery tool **708** that can be used to tighten the knot **714** once the fixation device is secured into the annular tissue. FIG. 25C shows the placement of two anchors **709**, or fixation devices (anchors and bands), after they have been delivered to the annulus and before the bands **709** have been tightened. The knot pushers **716** of both devices are still in contact with the knots and the delivery needles have been pulled back, away from the annulus. FIG. 25D shows the final placement of the two anchor bands after drawing together the tissues surrounding the aperture **717**, the inner wall of the annulus **712**, and/or the outer wall of the annulus; and, after tightening and cutting the knot located on each anchor band. Although this FIG. 25 shows the passage of the bands superior and inferior to the aperture, these bands could also be placed in a multitude of locations to effect desired or equivalent outcomes.

[0184] In addition, as previously described, one could use barbs having a multitude of configurations. One could also configure delivery devices to deliver one (as in FIG. 26), two (as in FIG. 24A), or more barbs simultaneously, and according to predetermined or variable distances or patterns. The delivery devices may also be configured to eject one, two, or more barbs sequentially. Further, the barbs could be delivered by a delivery device that does not require a cannula to cover the barb. In such a configuration, the barb may be disposed on

the tip or outside of the delivery device's shaft, and removed therefrom upon injection into the desired location of the annulus or other tissue. Bands and knots may be pre-tied to accommodate each configuration, as previously discussed.

[0185] For example, although FIGs. 24 and 25A-B depict a device that places two anchors **709** banded together with one device, one could accomplish an equivalent or other desired result with a single device that delivers multiple barbs at the same time.

[0186] FIG. 26 shows an alternative delivery device that delivers two or more anchors (or barbs) from a single cannula **711**. In this embodiment, a first single anchor **709** is ejected from the cannula **711** by pushing the ejection rod **715** a first distance sufficient to eject the first anchor **709**, but insufficient to eject the second. Then the delivery device is removed from the first site and passed into another annular location. The second anchor (or barb), not shown, connected to the first anchor or barb by band, is ejected out of the cannula **711** by pushing the ejection rod **715** an additional distance sufficient to eject the second anchor **709** (or barb) into a second fixation point in the annulus.

[0187] Although much of this description has described placement of the anchors into the annulus (or soft tissue) of the disc, one could perform anchoring into other tissues surrounding the aperture, including the bone or Sharpey fibers, it is also contemplated that, given the delivery device construction, a bone drill or similar device may be necessary to facilitate the placement of the delivery device through the bony or similar tissue.

[0188] The band **709**' connecting the thus implanted anchors (or barbs) advantageously contains a moveable knot **714** between the anchors. Suitable knots include, but are not limited to, the Roeder knot and its functional equivalents, and are advantageously, but not necessarily, pre-tied. After insertion of both anchors **709** (or barbs), the band **709**' is advantageously tightened by hand or by pushing on the knot with a knot-pusher or similar device. Although not shown in FIG. 26, the knot pusher may be integral to the delivery device. After drawing together the tissues surrounding the aperture, inner wall, and outer wall of the annulus, the excess suture line can be cut. It is also possible to use a

cutting device integral to the delivery device to cut the band after cinching. Although the device shown in FIG. 26 depicts two anchors being delivered from a single device, multiple anchors or barbs could be delivered from the same or a similar type of device. Additionally, a delivered configuration of fixation means may result from the use of a single device to deliver multiple anchors sequentially.

[0189] The shaft of the device may be of any convenient length, typically from, e.g., 1 inch to 10 inches. Materials of which to make the delivery device include, but are not limited to: metals, such as stainless steel, nickel, titanium alloy, and titanium; plastics, such as PTFE, polypropylene, PEEK, polyethylene, and polyurethane, acrylic, polycarbonate, engineering plastics; and/or composites.

[0190] Advantageously, the shaft of the device will have a cross-sectional shape suitable to accommodate an ejection rod and at least one fixation element, or portion thereof. In one embodiment, at least a portion of the shaft of the device may be hollow, having a circular, elliptical, triangular, trapezoidal or other suitable cross-sectional area sufficient to accommodate an ejection rod.

[0191] The delivery device may also contain a handle or raised surface configured to accommodate the shape of surgeon's hands or fingers for easier handling. Such raised or configured portion may be made of the same or different material as the tube or shaft. Suitable materials known in the art include, among others, polymers, such as acrylic polymers, polyurethane, polycarbonate, engineering plastics; and metals, such as stainless steel and titanium.

[0192] Much of the previous discussion relates to the use of a patch (or stent) for annular repair and/or reconstruction. In some clinical instances, the method of the invention may be accomplished without the use of a patch, however. For example, a patch may be unnecessary to repair small apertures or apertures of certain shapes, or certain weakened or thin portion(s) of an annulus. The invention therefore also encompasses methods for repairing or reconstructing annular tissue that do not necessarily involve the use of a patch, and to fixation devices and tools useful in carrying out these methods, as exemplified in FIG. 25. Accordingly, an additional embodiment of the invention

also provides fixation devices that may be used to reapproximate and hold annular tissue. Such fixation devices, as described herein, may contain an anchor portion and a band portion. The anchor portion serves to fix the fixation device in the annular tissue. The band portion, attached to the anchor portion, serves to draw together annular tissue when tightened and secured. At least one fixation device is placed into, or through, the wall of an annulus surrounding an aperture, weakened, or thin portion of the annulus. The device is then drawn in tension to pull together, wholly or partially, the surrounding annular tissue.

[0193] The band and the barbs may be separate elements or comprise one continuous element. Bands and barbs may be made of the same or different materials.

[0194] The bands may be string-like, made from suture or similar material, or of any construction or dimension that is amenable to the delivery and engagement of the fixation device. For example, the band may have a width greater than, in some embodiments far greater than, its thickness. The suture material may in some embodiments have a width:height ratio of 1.25:1. In some embodiments, bands may be constructed, wholly or partially, of a mesh tube. Moreover, different segments along the length of the band may have different dimensions and constructions. For example, the band may be constructed of thin material, such as nickel titanium alloy or stainless steel wire, close to the anchor barbs, while the middle portion that spans the aperture may comprise a much wider band made of optionally softer material.

[0195] Figures 21, 22, and 23 show additional examples of embodiments of the invention for repair or reconstruction of the annulus that could be utilized without the additional use of a patch. For instance, in FIGs. 21A-21C, in lieu of (or optionally in addition to) a patch, two anchors are shown having passed through the annulus to the subannular space. By drawing on band **910**, the inner and outer walls of the annulus may be drawn together in tension, and may also reapproximate the tissue surrounding the aperture. FIG 57C shows a single anchor band being placed along an incision or tear in the annulus.

[0196] The fixation devices of the invention could be delivered as a pair of barbs attached by a single band, or each barb could be delivered individually. Alternatively, multiple barbs (anchors) may be pre-attached to a single or multiple bands for ease and speed of delivery. For example, FIG. 23 shows a fixation device that has multiple anchors **916** (or barbs, not shown) connected together in a configuration similar to FIGs. 22B and 22C, with each anchor **916** being delivered individually into, or through the nucleus or annulus. The anchors, if present, may be shown as in FIG. 23. By drawing on the cinch line, the tissues surrounding the aperture and/or the inner wall of the annulus and/or the outer wall of the annulus are drawn together. Although a knot **914** is shown to affix the suture lines together, other means to lock, fasten clip, retain, or secure the sutures together may also be used.

[0197] An additional exemplary depiction of fixation devices that may be used to reapproximate and hold annular tissue as previously described in FIGs. 21-23 can be seen, for example, in FIG. 78. In FIG. 78, an anchor band assembly **308** and its complementary delivery tool **400**, as exemplarily depicted in FIGs. 42 and FIGs. 47-56, are used to repair a damaged, degenerated, weakened, or thin portion in an intervertebral disc annulus having, for example, a circumferential tear **216** compromising the integrity of the annulus. Anchor band assembly **308** may draw in tension the annular tissue surrounding the tear or delamination of the annular laminae, helping to fortify, reconstruct, augment, repair, or otherwise reinforce the annular tissue.

[0198] A further exemplary embodiment of the invention in the form of a braided patch **1100** such as depicted in FIGs. 24-32, is a further illustrative embodiment of the present invention that can be deployed into the subannular space to act as a barrier to the extrusion of the nucleus pulposus, or other intradiscal material.

[0199] The "patch" **1100** is constructed from a braided tube of filaments **1102**. The ends **1104** of the braided tube are heat-sealed to keep the braid from unraveling and the seals also provide structural integrity to the patch when deployed. Although the devices described herein principally utilize heat sealing

for forming the ends of the device, there may be a variety of ways to fixate, secure or otherwise form the ends of the device through the addition of other materials to add structure to the filaments, to include, but not limited to, the addition of collars or sleeves, dipping the ends in a material to fixate (i.e., heated polymer, adhesive). These added materials could be metallic or polymeric.

[0200] The braided patch **1100** is woven on a braiding machine with multiple filaments **1102** to create the structure. For example, the patch can be woven with 72 polyester filaments in order to create the construct that readily deploys into the annular defect, promotes tissue or matrix ingrowth into the device, and retains an anchor after it has been placed through the wall of the annulus and through the patch. Changing the number of filaments **1102** in the patch, the material of the filaments, the dimension of the filaments (e.g., diameter), as well as the configuration of the filaments (e.g., cross-sectional area), or changing the braid pattern, can create differences in the characteristics of the patch. The braided patch can be made on a standard Steeger braider, or similar type braiding machine, that can handle braiding from anywhere from 16 filaments at a time, to up to 196 filaments. Preferably the patch is braided with between 32 to 144 filaments. In one exemplary embodiment of the present invention, the device is braided with 72 filaments of polyester filaments, with every other braid filament being approximately 0.012" diameter, alternating with yarn (e.g., approximately 64 microfilaments, each approximately 17 microns in diameter, bundled) or alternating with a polyester braid monofilament approximately 0.004" in diameter.

[0201] In addition, much of the description herein depicts devices that generally have a tubular form, although it is also anticipated that these devices could be woven on the braider (i.e., by changing the configuration of the braiding mandrel), or re-formed in processing (i.e., heat forming) to obtain a patch construct that deviates from a "circular" cross section, in order to obtain different characteristics of the patch pre, during or post deployment to accommodate anatomical, physical, and biological considerations of the patient or the delivery of the implant. These device configurations may include square, rectangular,

oblong, symmetrical, non-symmetrical, triangular, "clover leaf", or other cross-sectional constructions that may be partially (i.e., only in a portion of the device body, and/or only in a portion of the device ends), or completely present throughout the device.

[0202] The filaments **1102** of the patch can be made of different materials or dimensions, or all of the filaments in a patch can be of like material and dimensions. The filaments can be biocompatible metallic material, such as a stainless steel, a nickel titanium alloy, or other metallic materials. The patch **1100** can also be made from biocompatible polymeric material such as polyethyleneteraphthalate (PET), polyester, polyethylene, polycarbonate urethane, polymethylmethacrylate, or polypropylene, for example. It is also conceivable that the patch can be braided from biodegradable materials, such as polyglycolic acid (PGA), polylactic acid (PLA), collagen (or its derivatives), fibrin (or its derivatives), cellulose (or its derivatives), polysaccharides (or its derivatives) or other biocompatible material that may degrade and/or be re-absorbed by the body over time.

[0203] It is also possible to braid the patch **1100** with multiple materials and/or multiple dimensions of the filaments. For example, the patch can be braided with 32 filaments of a polymeric PET material and 32 filaments of polyester yarn material to create a patch that may be optimal for sealing an annulus. The combination of different filament materials, sizes, cross-sectional configuration, number of filaments, and braiding pattern can be used to construct a braided patch that can be delivered into the sub-annular space, while acting as a scaffold to induce healing of the aperture.

[0204] The braided patch has advantages in that it can be placed through an aperture in the wall of the annulus that is relatively small, but then expand to a dimension that is substantially greater than the aperture. For example, it is possible to construct the braided tube to be less than 5 mm in diameter, whereas in its fully deployed state it could be greater than, for example, 20 mm. This is exemplary and is not intended to be construed as limiting in the actual dimensions of the device pre and post deployment

[0205] Referring to FIG. 28, the non-deployed braided patch **1100** is affixed on the distal end of the patch delivery tool **1200**. It is situated in a fashion that is co-axial **1208** with the delivery tool's delivery members, which include inner delivery member **1202**. A finger grip **1206** can be formed onto the proximal end of the delivery tool body to assist in manipulation. Further detail of the deployment mechanism can be seen in FIG. 29. The braided patch **1100** is placed on the distal end of the inner delivery member **1202**. The heat-set distal cuff **1104** of the patch is situated within a depressed region on the distal region of the inner delivery member **1216**. The distal portion of the delivery member **1216** is slotted as shown in FIG. 31, and, in the non-deployed state, contains a co-axial retention member **1208** that acts to press the slotted portions of the inner delivery member apart, and thus securing the distal cuff of the patch **1104** on the distal region of the inner delivery member **1202**. The proximal portion of the patch abuts and is in contact with an outer pusher member **1204**. In the non-deployed state, the delivery device is passed into the aperture of the annulus. Once inside the annular aperture, the outer pusher member **1204** of the delivery device **1200** is pushed toward the distal end of the device, while the inner delivery member **1202** is pulled proximally. This action of moving these members in such a fashion results in the braided patch expanding perpendicular to tube's axis, as shown in FIGs. 27 and 30.

[0206] Once the patch **1100** has been expanded to its fully expanded state, a cinch line **1212** that is connected to the distal and proximal ends of the patch can be tightened and a knot, such as a Roeder knot, can be used to hold the braided patch in its expanded configuration. Although, the device is shown with a cinch knot **1214**, it is possible that a locking element may not be needed, depending on the means used to fixate the patch into the annulus. It is possible that no locking means is necessary. It is also possible that alternative locking means can be contemplated to keep the braided patch in its expanded form. A knot pusher **1210** can also be employed to manipulate the knot locking device **1214**.

[0207] Once the device patch has been expanded into its final configuration in the aperture and subannular space, the retention member **1208** can be removed from the distal portion of the inner member by slidably pulling the proximal end of the retention member in a proximal direction. Removing the retention member relieves the stress holding the distal cuff of the patch in place and allows the patch to be slidably removed from the distal end of the delivery device, and thus deployed into the subannular space.

[0208] As depicted in FIG. 32, the patch **1100** can be affixed to the inner surface either before or after the deployment of the patch from the delivery device. It is also contemplated that this patch can be affixed to the inner surface of the annulus by the various fixation means described in other parts of this application. For example, anchor bands as shown in FIG. 32 could be used to penetrate the annulus **1306**, shown between vertebrae **1302**, and the patch to anchor the patch into the sub-annular space. It is also conceivable that single T-anchors **1310** with a band **1314** (e.g., suture) could be delivered through the annulus **1306** and patch **1100** with the portion of the suture on the outer surface of the annulus locked to the outer surface with a knot, pledget, or other locking device **1316**. Path **1312** illustrates another possible suture path through the bone of the vertebra to penetrate and hold a T-anchor member **1310** in the patch. It is also conceivable that the patch could be affixed to the inner surface of the annulus through the use of adhesives, such as cyanoacrylate, fibrin glue, polymer protein, polyurethane, compounds that mimic mussel shell adhesive proteins (manufactured by Nerites Corp.), adhesive materials that may be used as adhesives for dural or dermal wound repairs/sealing, or other material used to cure, or adhesively affix the patch in the subannular space in situ. The delivery of these adhesive fixation materials could be delivered through the patch delivery tool, as depicted in FIG. 76 or through the anchor band delivery tool, FIG. 77, or both. FIGs. 76 and 77 are illustratively intended to depict an alternative embodiment (further described below) of the invention in which a nuclear replacement material **218** may be delivered to the intervertebral disc, although they may also exemplify methods and devices to delivery adhesive materials. It is

also contemplated that if an adhesive were used to affix the patch to the annulus that an additional membrane material may be added to the patch device to further help restrict fluidic extravasation of the material out of the disc during adhesive delivery, if required. Conversely, the patch construction may be altered to reduce the patch porosity in order to accomplish a similar objective. Furthermore, it is anticipated that materials maybe added to, or changed, on portions the delivery tools to reduce the possibility of the tools being adhesively bonded to the instruments during delivery. For example, cannula **526** in FIG. 76 may be coated with, or be constructed of, PTFE, FEP, polypropylene, polyethylene or other lubricious materials or coatings. Similarly, portions of delivery device **400** in FIG. 77 may have similar material treatments to accomplish the same objective.

[0209] The advantages of the braided design, given the right selection of filament dimension, configuration, material, braid pattern, and number of filaments is that it can be easily delivered to the annular repair site, have the flexibility to take the shape of the annular defect while maintaining the mechanical integrity needed to remain within the disc space upon loading. Another advantage, again with the appropriate selection of material, filament configuration, braiding, dimensional considerations, and multiple filament weaves, is that one can construct a patch that is conducive, in its deployed state, for incorporation of fibrosis and the fibrotic healing of the annular defect. Finally, the patch can be designed so that when it is in its delivered state, it can easily receive one or more anchor bands through the braided filaments while retaining the T-anchor or other similar type fixation device, after passing the fixation device through the patch.

[0210] FIGs 33-41 depict an illustrative method for the deployment of a treatment device into the intervertebral disc **200**. As described previously, there are a variety of applications, approaches, techniques, tools, and methods for accessing and performing spinal disc surgery which may be dependent on physician preferences and could be arbitrary. Therefore, the following description and depiction of the method should be considered illustrative and not limiting. In the illustrative scenario which is used in the following descriptions, and with reference to FIG. 33, the disc **200**, which is comprised of the annulus fibrosus **202**

and the nucleus pulposus **204**, is shown in a transverse cross section. The disc **200**, as described above, is disposed anatomically between caudal and cephalad vertebral bodies, which a portion of a vertebral body (spinous process **206**) seen in FIG. 30. The disc **200** may be accessed for treatment via a surgical incision **208** made in the paramedian region lateral of the spinal canal **210**. A microdiscectomy procedure may precede the placement of a treatment device in order to remove disc fragments and to provide a subannular cavity **212**. The subannular cavity **212**, however, may be preexisting or may be created for the purpose of performing a nuclear augmentation. An aperture **214** in the annulus provides a path for the mesh or treatment device delivery tool **500** to place treatment device **600**. The treatment device **600** can take the form as described in the embodiments above, or as additionally described below with reference to FIGs. 63-64, as described in commonly-assigned copending U.S. Patent Application 10/352,981, filed on January 29, 2003 and incorporated herein by reference, or any other appropriate form. Likewise, the anchor band delivery device **400** can take the form as described in the embodiments above, or as additionally described below with reference to FIGs. 47-52, , as described in commonly-assigned copending U.S. Patent Application 10/327, 106, filed on December 24, 2002 and incorporated herein by reference or any other appropriate form.

[0211] As shown in FIG. 33, a delivery device **500** is introduced through surgical incision **208** to traverse aperture **214** and position treatment device **600** in subannular cavity **212**. As depicted, treatment device **600** is in a first configuration sized to permit its passage to the subannular cavity **212**. FIG. 39 shows a detail, sagittal view of mesh device **600** mounted on the distal portion **602** of delivery tool **500**, introduced to the cavity. Also shown are sections of intervertebral disc tissues. As illustrated, treatment device **600** may have element **608** to latch the mesh device once deployed into its final deployed configuration. If required, there may be a variety of ways to latch, lock or otherwise secure the device in its final configuration, as described previously, or additionally depicted and described below in FIGs. 71A-E below

[0212] As depicted in FIG. 34, the treatment device delivery tool **500** can be manipulated by, for example, pulling a finger grip **502** in the direction of arrow **300** to deploy treatment device **600** in the subannular cavity **212**. As illustrated here, this deployment involves a longitudinal shortening of the treatment device, drawing end **606** toward end **604**, resulting in a lateral expansion of the treatment device **600**. The pulling of the finger grip **502** may be preceded by the release of a safety lock **504** preventing deployment of the treatment device until intended by the surgeon. As illustrated here, the lock is released through rotation of handle member **504** in the direction of arrow **302**. Also shown is a marking **538** on the delivery tool **500** that may visually assist the surgeon in assessing the degree to which the device has been placed in subannular space.

[0213] FIG. 35 shows the finger grip **502** reaching its intended limit, and the concomitant full intended deployment of treatment device **600**, where end **606** reaches its intended design position for the deployed configuration of the device **600**. In this illustrative depiction, end **606** is pulled adjacent to end **604**, and device **600** has reached its maximum intended lateral expansion. As shown, the deployed device **600** may be pulled to internally engage and at least partially conform to the cavity **212**. Naturally, the full travel of the finger grip **502** can be determined by the design of the delivery device, or informed by the judgment of the surgeon through visualization, tactile realization, or the like. Once the intended limit has been achieved and the device fully deployed, the delivery device **500** can lock finger pull **502** in place so as to maintain the treatment device **600** in the deployed configuration. It may also be advantageous for the delivery tool **500** to have a perceptible (i.e., audible, tactile, visual) indication that the treatment device has been fully deployed. The mesh/patch delivery tool **500** may be of the type described hereinabove, or as additionally described in FIGs. 57-62 below, or in other sections of this disclosure.

[0214] FIG. 36 next depicts a fixation element or anchor band delivery device **400** introduced through surgical incision **208**, where the distal end **402** is passed through the annulus fibrosus **202** adjacent to the aperture **214**, and subsequently through treatment device **600**, as illustrated by arrow **190**. Fixation

element delivery tool **400** may have features to provide tactile feedback once the delivery tool has been introduced into tissue to an acceptable extent, for example a feature like tissue-stop **432**. As illustrated, delivery device **400** is passed distally until stop **432** and pledget member **309** of the fixation device **308** come in contact with the outer surface of the annulus. Alternatively, and without tissue stop **432** use, pledget member **309** could be of construction to similarly resist, or otherwise visually or tactilely indicate ceasing the passage of delivery device **400** through annular tissue. FIG. 44 shows a detail, sagittal view of a distal end of a fixation element delivery tool **400** introduced into disc tissue and through treatment patch **600**. As shown in FIG. 44, one fixation element has been deployed and fixated. FIG. 44 also depicts an exemplary treatment device detection feature **442** on the outer surface of needle cannula **428**, as more clearly illustrated in FIG. 48. The patch detection feature **442** on the distal end of needle cannula **428** may advantageously provide perceptible feedback (tactile and/or audible) to the surgeon that the anchor band delivery tool has accessed and penetrated the patch and it is therefore acceptable to deliver the band. Feature **442** is discussed in more detail below. In operation as illustrated in FIG. 36 and in FIG. 37, the delivery device **400** can be manipulated similarly to the treatment device delivery tool. For example, moving finger grip **404** in the direction of arrow **304** will withdraw a portion (for example, the slotted needle cannula **428**) of distal end **402** of the device **400** and deploy a fixation element **308**, as more described below, in the subannular cavity **212** to secure the treatment device **600**. The pulling of the finger grip **404** may be preceded by the release of a safety lock **406** preventing deployment of the fixation element until intended by the surgeon. As illustrated here, the safety **406** is released through rotation of safety **406** in the direction of arrow **306**. The fixation element delivery tool **400** may be of the type described hereinabove, or as additionally described in FIGs. 47-56 below, or in other areas of this disclosure

[0215] FIG. 37 depicts the deployment of a fixation element, **308** into disc tissue following the deployment of FIG. 36. The fixation device may be as described above, for instance a T-anchor, suture, tether, knot, pledget or barb.

As illustrated here, the fixation element **308** is a T-anchor with suture bodies, knot, and pledget as more fully described below. During the pulling of finger grip **404** and retraction of slotted needle cannula **428**, a knot pusher end **406** of inner cannula **426** is shown holding a proximal portion of the fixation device's **308** slip knot **440**, while T-anchor **316** is drawn in tension proximally by tether or suture line **310**, to adjust the length of the fixation element **308** to provide the proper tension to securely hold the treatment device **600** in situ. A proximal end of the fixation element, such as a pledget **309**, is held or urged into engagement with a bearing surface on the exterior of the annulus. The proximal end of the fixation device can also include a T-anchor or knot or similar tissue locking element. FIG. 48 is a cross sectional view of the distal end of delivery tool **400** as it may be introduced in disc tissue. FIG. 55 shows the distal end of the delivery tool **400** after retraction of the slotted needle cannula **428** and tensioning and drawing T-anchor **316** proximally to a potential final state. The proximal drawing of T-anchor **316** is also illustrated in a detail, sagittal view in FIG. 45, with arrows **324** illustrating motion of the T-anchor. The construction of the locking element **316** is exemplary and is not intended to be limiting of alternative constructions of **316**, such as one or more pledgets, knots, barbs or other forms to effect the same function.

[0216] FIG. 38 shows the partial withdrawal of the fixation element delivery device once the fixation element has been deployed. In the illustrations shown, the final step during the pulling of finger grip **404** proximally results in the release of the fixation element in situ. The release may be accompanied by visual or tactile or auditory confirmation, such as a click. Once released, the fixation element delivery tool can be completely withdrawn as shown in FIG. 39, leaving the suture body **310** of a fixation element extending through the surgical incision **208**. The proximal portion of suture body **310** may be cut to a suitable length with readily available surgical tools such as a scalpel or surgical scissors and removed from the surgical site. FIG. 43 shows a detail, sagittal view of a single deployed anchor band assembly **308** with T-anchor **316**, pledget **309**, slip knot **440** and associated tether components **318** and **310** (after it has been cut in the epi-

annular space). Also shown are portions or sections of intervertebral disc tissues. As shown, fixation element **308** is fixedly engaged with the disc tissue and the patch **600**. FIG. 40 depicts the treatment device **600** after placement of 2 fixation devices **308**, as does FIG. 46 shown in a detail, sagittal view. Of course, any number of fixation devices appropriate to secure the treatment device **600** can be used. It is also anticipated that device **600** may be of a construction and design, as described herein, that does not necessitate anchor bands to effect securement of device **600** within the disc space and therefore, illustrations using fixation elements are to be exemplary, and not limiting. Once secured, the treatment device **600** is released from the delivery tool **500**. As illustrated here, this is accomplished in a two-step process. First the release mechanism is enabled by rotating knob **506** in the direction of arrows **312**. An indicator may then be activated as shown by arrow **320** of indicator **508** in FIG. 41, such as spring-loaded release indicator **508** to notify the surgeon that the treatment device has been released from the delivery tool **500**. Accompanying the deployment of indicator **508** is the uncoupling of the treatment device **600** at the distal end **602**, as will be described in greater detail below. The delivery tool **500** can then be withdrawn as depicted in the transverse view of FIG. 41, leaving treatment device **600** in situ.

[0217] FIGs. 47-53 depict illustrative embodiments of an fixation element delivery tool (or FEDT) as discussed above, which may be referred to alternatively as an anchor band delivery tool (or ABDT). The fixation element **308** is depicted as loaded in the distal end **402** of the ABDT, which will be discussed in greater detail with reference to FIG. 48. The ABDT **400** is comprised of a main body member **410** which may be fixedly attached distally to outer cannula **422**, and also to inner cannula **426** at inner cannula anchor **438**. Distally, inner cannula **426**, as better illustrated in detail in FIG. 48, may comprise a knot pusher (or other means to effect securement of suture tethers **310** and **318** with locking element **440**) and T-anchor stand-off **434**. Proximally, main body **410** has disposed safety member **406** with an outside diameter telescopically and rotatably received in the inner diameter of a knob **408**. Knob **408** and main body member

410 are rigidly attached to one another. Slidably disposed within the lumen of the main body member **410** is suture retention block **414**, depicted with suture body **310** threaded through its center hole. A spring **316** is also slidably disposed within the lumen of the main body member and can abut either suture retention block **414** or slider member **418**. Slider member **418** can be integral with finger grip **404** (not shown) as depicted in FIGs. 36-38. Attached to the proximal end of slider member **418** is a suture cutting blade assembly **420**. The blade assembly, as will be discussed in greater detail below, serves to sever the suture body after deployment of the fixation elements as described herein. A slot in the slider member **418** allows the slider member **418** to slide past the outer cannula anchor **426** and, as described previously, **426** may be stationary with respect to main body **410**. A slotted needle cannula **428**, slidably disposed in the lumen of the outer cannula **422**, is secured the distal end of slider member **418** by needle cannula anchor **430**, such that the translation of the slider member **418** within main body member **410** concomitantly translates the slotted hypotube **428** within the outer cannula **422**.

[0218] FIG. 48 is a detailed view of the distal end **402** of the ABDT **400**. As described above, the slotted hypotube **428** is slidably received in the outer cannula **422**. A tether, consisting of a suture line **318** and a pledget body **309** is located in proximity to an optional tissue stop **432** on the outer cannula **422**. It is also possible for pledget **309** to be held by an optional outer cannula pledget holder **433** until release of the anchor band. The suture line **318** is slidably knotted to suture body **310**. The distal end of suture body **310** is attached to T-anchor **316**, which is held by T-anchor stand-off **434**. As described above, T-anchor stand-off **434** and knot pusher **436** may be components of inner cannula **426**. In the initial configuration, needle hypotube **428** extends distally of outer cannula **422** and allows the point of slotted hypotube **428** to extend distally of the T-anchor holder **434**.

[0219] FIGs. 47 and 48 depict the ABDT in its initial delivery configuration. The ABDT is locked in this configuration by the distal end of safety **406** engaging

the finger grip **404** (not shown) as depicted in FIGs. 36-38. Turning now to FIG. 36, the rotation of handle member **406** in the direction of arrow **306** allows the finger grip **404** (not shown) to engage a slot on safety **406**, and permits the surgeon to pull finger grip **404** proximally toward the proximal knob **408**. Doing so results in the translation of the slider member **418** proximally, and concomitantly, the proximal translation of the slotted needle cannula **426** (as a result of slotted needle cannula anchor **430**) in the direction of arrow **326** (illustrated in FIG. 45). The result, as discussed above, is the unsheathing by the needle **428** of T-anchor **316** held by T-anchor holder **434**. The translation of the slide body **418** proximally also urges the spring **416** and suture retention block **414** proximally. The suture retention block **414** is attached to suture body **310**, and therefore tension is leveraged onto the suture body **310** to hold it taught and, when appropriate, draw T-anchor **316** from within the delivery tool to a position proximally

[0220] FIGs. 50 and 51 illustrate the partial deployment of anchor band assembly from ABDT, wherein slotted needle cannula **428** has been partially retracted to expose T-anchor **316**. FIG. 49 is a detail, cross sectional view of the distal end of the handle of ABDT **400**, illustratively showing the inter-relationships of delivery tool components in the initial configuration and FIG. 52 is a similar detail, cross sectional view showing the inter-relationships after at least a partial deployment of device **400**. FIG. 53 is a detail of the suture retention body **414**, suture body **310**, spring **316** and cutting assembly blade **420**, during partial deployment of delivery tool **400**, as discussed above.

As depicted in FIG. 54 and detail drawings of FIGs. 55 and 56, as slider body **418** continues to slide proximally, in addition to continuing to draw T-anchor as shown in FIG. 55 with arrows, the tether retention block **414** reaches the limit of its proximal translation (discussed further below), and the slider member engages and compresses spring **316**. As the spring is compressed, the blade assembly **420**, which is aligned with the hole of suture retention body **414** through which suture body **310** passes, comes into engagement with the suture body **310**. FIG.

56 is a detail view of the blade **420** severing the suture body **310**. Up to the limit of travel of the suture block **414** and the severing of tether **310**, the suture body **310** continues to apply tension to the T-anchor, as shown in greater detail in FIG. 55. With knot pusher holding knot **440**, pledget **309**, and suture **318** in apposition, and in distally exerted fashion, to the tensioning of suture body **310**, anchor band assembly **308** is advantageously cinched into a fixing and/or compressive relationship between ends **309** and **316**, as well as any structures (e.g., nucleus, annulus, treatment device) between elements **309** and **316**. After severing suture body **310**, suture body **310** is still attached, to the anchor band, but has at this point been severed proximally. The suture body **310** will therefore be unthreaded from the interior of the ABDT as the ABDT is withdrawn. As discussed above the suture line **310** may be further cut to length with readily available surgical scissors. Alternatively, a severing mechanism similar to those described herein in the distal portion of tool **400** may be employed to avoid an additional step of trimming the end of body **310**.

[0221] FIG. **53** is a detail of the suture retention body **414**, suture body **310**, spring **316** and cutting assembly blade **420**, during partial deployment of delivery tool **400**, as discussed above

[0222] Additionally inventive of the anchor band device (and its delivery and deployment tools) is the unique inter-relationship of the slide body, spring, and the tension delivered to the T-anchor and tissue during deployment. For example, T-anchor assembly can be designed to pass through softer, or otherwise more pliable tissues (e.g., nucleus pulposus, softer annular layers) while resisting, under the same tension, passage through tougher tissues and/or substrates (e.g., outer annular layers, treatment device construct). In further illustrative description, tension delivered to the suture line **310** can be limited by the interface between the slide body member **318** and the suture retention block **414**, through spring **316** such that tension is exerted on T-anchor body **316** which may sufficiently allow movement of T-anchor **316** through softer tissue, but alternatively requires a greater force to pull T-anchor body through other materials or substrates such as the treatment device **600** or outer layers of the annulus **202**.

Spring **316** can be designed to sufficiently draw tissues and/or the patch together, while not overloading suture line **310** when the fixation has been effected. Spring **316** may also be advantageously designed to allow blade assembly **420**, upon reaching an appropriate loading to effect the delivery, to sever the suture line **310**. As illustrative example, but not intended to be limiting, T-anchor body and suture line may be constructed to require approximately 5 pounds of force to draw the T-anchor assembly through nuclear tissue, but substantially greater load to draw T-anchor through annular tissue and/or patch device. Spring may be designed to exert approximately 5 pounds, sufficiently pulling anchor through nuclear tissue, and in proximity to treatment device, as intended. Once sufficient load has been applied to move T-anchor to engage patch, the loading on the suture line is not allowed to substantially increase. Advantageously, additional loading would cause the final compression of spring between suture retention block and blade assembly to sever suture line. Preferably, the severing and the design of the tether elements are such that the ultimate strength of the suture line is greater than the load required to draw T-anchor through soft tissue, or the like, and less than the load inflicted to cause the severing by blade assembly. The description herein is intended to be illustrative and not limiting, in that other device and delivery tools could be derived to employ the inventive embodiments.

[0223] FIGs. 57-62 depict illustrative embodiments of a therapeutic device delivery tool (TDDT), or mesh delivery tool (or MDT) as discussed above. The treatment device (or mesh or patch) **600** is depicted as loaded in the distal end of the TDDT **500**, which will be discussed in greater detail with reference to FIG. 58. The TDDT **500** is comprised of a main body housing **510** which may be fixedly attached distally to outer cannula **522**, which in a lumen thereof slidably receives a holding tube assembly **526**. Distally, holding tube **526**, as better illustrated in detail in FIG. 58, may comprise a slotted end and accommodate an actuator rod or stylet **514** in an inner lumen. Proximally, main body **510** has disposed thereon safety member **504**, and has an outside diameter telescopically and rotatably received in the inner diameter of cap **506**. Cap **506** forms part of end cap assembly **524**, which also comprises ball plunger assembly **536**, which will be

described in greater detail below. Slidably disposed within the lumen of the main body member **510** is actuator body assembly **518**, which abuts at its distal end, optionally in mating fashion or via detents, against a proximal end of finger grip member **502**, which is also slidably disposed in the lumen of main body **510**. At the proximal end of the actuator body assembly **518** is formed device release indicator **508**, which will be described in greater detail below. A spring **516** is also slidably disposed within the lumen of the main body member and can abut either actuator body assembly **518** or finger grip member **502**. The finger grip member can optionally comprise finger members at a distal end, carrying detents to engage with tabs, slots, or other cooperative structure on the inner lumen of main body **510** to lock the finger grip member, aggressively or gently, in the undeployed (unused) or deployed (used) configuration. A holding tube assembly, in the form of a slotted hypotube needle cannula **526**, is slidably disposed in the lumen of the outer cannula **522**, and is secured to the distal end of actuator body assembly **518**, such that the translation of the finger grip member **502** proximally within main body member **510** concomitantly translates the actuator body assembly **518**, and thus holding tube assembly **526** within the outer cannula **522**.

[0224] FIG. 58 is a detailed view of the distal end **602** of the TDDT **500**. As described above, the holding tube assembly **526** is slidably received in the outer cannula **522**. The TDDT is designed to releasably deploy the treatment device **600** after the distal end **602** is navigated by the surgeon to the intended deployment site. The treatment device **600**, shown in cross section and discussed further below, comprises a proximal end, forming a collar or cuff **604**, and a distal end, also forming a collar or cuff **606**. The proximal end **604** is slidably disposed on holding tube assembly **526**, and abuts and is held stationary by outer cannula **522**. The distal end of the holding tube assembly **526** can be formed to carry treatment device latch **608**. The device latch **608** is formed with a flange or other detent to engage the distal end of treatment device **600**, preferably the distalmost end of distal collar **606**. The slotted end of holding tube

assembly **526** is held radially rigid by actuation rod **514**, such that the treatment device **600** is held firmly on the distal end **602** of the TDDT **500**.

[0225] FIGs. 57 and 58 depict the TDDT in its initial delivery configuration. The TDDT is locked in this configuration by the distal end of safety **506** engaging the finger grip **502**. Turning now to FIG. 59, the rotation of safety **506** in the direction of arrow **302** allows the finger grip **502** to engage a slot on safety **506**, and permits the surgeon to pull finger grip **502** proximally in the direction of arrow **300** toward the proximal cap **506**. Doing so results in the translation of the slider member **518** proximally, and concomitantly, the proximal translation of the holding tube assembly **526**. The result, as further illustrated in FIG. 60, is the movement of the distal end **606** of treatment device **600** moving toward the proximal end **604**, resulting in a bulging or lateral expansion of the treatment device **600**. The translation of the actuator body assembly **518** proximally also urges the device release indicator **508** proximally, as will be discussed further below.

[0226] FIGs. 60 depicts the distal end of the TDDT **500** after fully withdrawing the finger grip member **502** proximally, as discussed above. When the finger grip has reached the limit of its intended travel upon being pulled by a surgeon, the treatment device **600** will be in its deployed configuration. In this configuration, detents on the proximal end of treatment device latch **608** will be poised to engage the proximal end **604** of treatment device **600** to hold it in the deployed state. As illustrated in FIG. 60, the actuation rod **514** can be seen to hold the distal end of the holding tube assembly **526** engaged with the distal end **606** of the treatment device **600**, providing for maneuverability or removal until released.

[0227] FIGs. 61 and 62 illustrate the final deployment of the treatment device **600** just prior to withdrawal of the TDDT. As shown in FIG. 61, the rotation of cap **506** in the direction of arrow **312** releases actuator body assembly **518** from ball plunger **536**, permitting its translation proximally under the bias of spring **516**. Translation of the actuator body assembly **518** withdraws actuator rod **514** in the proximal direction, which permits the release of the treatment device **600**

from the distal end of the TDDT, as further described with reference to figure 62. The translation proximally of actuator body assembly **518** permits indicator **508** to emerge from a hole in the cap **506**, providing a perceptible indication to the surgeon that the TDDT can be removed and will leave the treatment device *in situ*. Turning to FIG. 62, the withdrawal of the actuation rod **514** is illustrated, which allows for inward radial compression of the tip of the holding tube assembly **526**. Once the distal end of the holding tube assembly **526** is compressed radially inwardly, it can then pass through the inner diameter of the treatment device latch **608**, and allow withdrawal of the entire TDDT from the treatment device **600**. The final disengagement of the distal end of the outer cannula **522** can advantageously permit the engagement of detents on the treatment device latch **608** to engage the proximal collar **604** of the treatment device **600**, locking it in a deployed configuration.

[0228] Additionally inventive of the treatment device (and its delivery and deployment tools) is the unique inter-relationship of the actuator body, spring, and the holder tube assembly, allowing the device to be deployed while still holding the device firmly during deployment. The use of the actuator rod to stiffen the distal end of the small diameter outer cannula, and the use of a radially compact treatment device offers additional advantages, such as the ability to pass through softer, or otherwise more pliable tissues (e.g., nucleus pulposus, softer annular layers) while resisting columnar bending during navigation. As an illustrative embodiment, a mesh patch as described in FIGS. 63 and 64 can be employed, but such a device configuration is not intended to be limiting. Other devices that expand radially through linear actuation can also be used.

[0229] The spring may be designed to exert approximately 5 pounds, sufficient to provide tactile control while preventing inadvertent release of the treatment device. By requiring actuation of the device in a different direction for release (*i.e.*, rotation of the proximal cap) than that required for initial deployment (*i.e.*, proximal translation of the finger grip), each with tactile, auditory or visually perceptible confirmation, safe an affirmative deployment can be achieved.

[0230] FIGs. 63 and 64 depict anterior views of the distal end **602** of the TDDT and treatment device **600** following deployment. FIG. 63 shows the distal end of holding tube assembly **526** engaging the treatment device latch **608**. FIG. 64 shows the distal end of **526'** disengaged, following withdrawal of the actuation rod **514** as discussed hereinabove.

[0231] Additional embodiments of treatment device **600** might include constructions that can be "inverted" or "non-inverted" at the either, or both, ends of the device. As illustratively depicted in FIGs. 66A-66C, device **600** is shown in its deployed state, and FIG. 66C may be exemplary of devices described previously wherein distal device portion **606** has a "non-inverted" configuration, shown with distal cuffed portion extending distally, and away, from the body of device **600**. Similarly, FIG. 66C reveals a proximal portion **604** of device **600** extending proximally, and away, from the body of device **600**. Conversely, FIG. 66B illustratively demonstrates a proximal portion of device **600** in an "inverted" construction, shown with proximal cuffed portion extending distally, and towards, the body of device **600**. Advantageously, a deployed configuration with inverted proximal portion of device depicted in FIG. 66 may allow less material of the device to project proximally, in use, and possibly reduce risks of causing injury to elements outside of the disc, including if a device were to expulse from the disc subannular space. FIG. 66A depicts a device construction in which both end portions of the device are "inverted". Changing constructions on ends of the device may also, advantageously, facilitate device **600** deployment and/or device function in the repair of an aperture, weakened, or thin portion in the annulus fibrosus.

[0232] In alternative embodiment in the construction of device, such as, for example implant **600**, devices may be pre-set in a heat forming process to induce the device to have different structural or physical characteristics during the introduction, delivery, deployment, fixation or otherwise use of the device to treat a treatment site. An illustrative example of a pre-set heat forming process is shown in FIG. 67 wherein device **600** is shown in cross section through a longitudinal axis. As shown, device **600** is folded along four axial dimensions in

its undeployed state. A configuration, such as shown, could, for example, advantageously reduce the radial profile of the device in order to facilitate introduction into the subannular cavity or provide other benefits in the functioning of the device and its delivery. Such a benefit is illustrative, is not intended to limit the many other beneficial effects of altering configurations of devices, or their components as described herein. After deforming the device into a desired configuration, the device may be held in a mold or similar retention apparatus and subjected to a heating process to "heat-set" the material of the device. Naturally, temperature and time duration of heat-setting process are dependent on a device's (and/or components of a device) materials. As an example, but not intending to limit the scope of the invention, if device were comprised of polyethyleneterephthalate (PET) the heat-set process might be accomplished in a temperature range above the material's glass transition temperature (typical glass transition temperatures of various PET's range from approximately 160 degrees Fahrenheit to approximately 180 degrees Fahrenheit) and below the material's melting temperature (typical melting temperatures of various PET's range from approximately 450 degrees Fahrenheit to approximately 550 degrees Fahrenheit). One skilled in the art would realize that this process is illustrative and will vary depending on the material and the intended characteristics of the device., and therefore should not be limiting in the scope of the invention.

[0233] Although FIG. 66A exemplifies a device that is folded along the axis in four equidistant creases, it is clear that the device could be constructed with a single fold or multiple folds, and that four folds is only an example. It is also possible that a single fold or more could be located in a fashion that does not result in a geometrically spaced folds along the axis, for example, a device might have two folds located on generally one side of the device. In addition, it is also possible that one might beneficially construct a configuration in which only a portion of the device has a fold along its longitudinal axis. Further, it is also possible to obtain alternative characteristics of the device by creating one or more circumferential folds (partially, or wholly) along longitudinal axis of a device.. It is also possible that the device may have a combination of axial, radial, or otherwise

special heat set folds or configurations to beneficially affect the characteristics of the implant.

[0234] In additional alternative embodiments, it may be possible to perform alternative processes on the implant that may alter the structural or physical characteristics of the device, advantageously inducing the device to evince beneficial characteristics during the introduction, delivery, deployment, fixation or otherwise use of the device to treat a treatment site. For example, it is possible to provide heat to selected regions of a device to heatmelt, heat seal, or otherwise flow and/or fixate various components of a device in selected regions, thus causing the device to have different characteristics during the pre-deployment, deployment or post-deployment of the device. Inclusive in the inventive embodiments are elements that are fixedly attached to at least an element of a device to also effect beneficial characteristic changes of an otherwise unaltered device. The elements may, or may not be of similar materials as the treatment device. FIG. 68A shows a side view of device **600** with a single rib **640** of material affixed to the device, or conversely a rib **640** created by heat setting the material of the device. It should be understood in the description and depictions herein that the rib **640** can be constructed of either form, and the descriptions is intended to be illustrative and not limiting. FIG 68A exemplifies a single rib **640** element placed along the longitudinal axis of a device **600** having end portions **604** and **606**. FIG. 68B shows an expanded configuration of device **600** of FIG. 68A as seen from the proximal portion **604** of device **600**. As can be seen, the rib **640** may advantageously change the configuration of a device to induce the device to have different structural or physical characteristics during the introduction, delivery, deployment, fixation or otherwise use of the device to treat a treatment site. Applying heat sealing to a treatment device may be accomplished by a process similar to heat setting, although the temperatures and duration of time of the process would most likely differ. Naturally, temperature and time duration of heat-sealing processes are dependent on a device's (and/or components of a device) materials. As an example, but not intending to limit the scope of the invention, if device were comprised of polyethyleneteraphalate (PET)

the heat-seal process might be accomplished in a temperature range slightly below, equal to, or above the material's melting temperature (typical melting temperatures of various PET's range from approximately 450 degrees Fahrenheit to approximately 550 degrees Fahrenheit). One skilled in the art would realize that this process is illustrative and will vary depending on the material and the intended characteristics of the device., and therefore should not be limiting in the scope of the invention. There are a variety of methods that may be used to apply heat-sealing processes, welding, or otherwise melting the material of a device, such as laser, heat iron, RF, and ultrasound. Although FIG. 68 shows as single rib along the device, it is anticipated that the device could have any combination of radial, axial, or otherwise special ribs or rib configurations to beneficially affect the characteristics of the implant, as are further illustrated in FIGs. 69A-D. FIGs 69A, 69C, 69C, 69D illustrate multiple ribs on device 600. FIG. 69A illustrates ribs aligned a longitudinal dimension of the device. FIG 69B is exemplary of a circumferential rib, with 69C illustrating partially applied ribs in a circumferential fashion. FIG. 69D is illustrative of ribs that may be applied to a device that are neither circumferential nor longitudinal and illustrative that alternative rib patterns may be employed.

[0235] Changing characteristics of the treatment device with various ribbing effects may be performed for a variety of reasons, as an example (and not to be limited in scope of the invention), one might prefer to change the base (e.g., unaltered) characteristics of a device to accomplish, for example, a lower profile of the device while mounted on its delivery tool, or during its deployment. Alternatively, one might want to change the symmetry of the deployed device to open with different configurations to address different anatomical considerations of the treatment site. For example, one might prefer that a deployed device be placed predominantly, more medially of an aperture of a annulus fibrosus. Alternatively, it is possible that one might want to increase the structural integrity of the patch during delivery to provide more radially directed force into soft tissue, for example nuclear tissue, in order to better deliver the device into the intervertebral disc. The drawings and descriptions of ribs and heat sealing

elements, and the resulting beneficial outcomes, above and herein are intended to serve as examples to altering the configuration through various processes applied to a device, although, they are only intended to serve as examples, and should not be considered exhaustive of the advantages of changing the characteristics through various heat sealing altering processes, or alternative procedures that apply rib elements to a device.

[0236] Heat sealing, in an embodiment of the invention may be used to heat melt, fasten, or otherwise secure the device ends **606** and **604** of the filaments of device **600**, as discussed previously. Some of the devices described herein may illustrate end portions as radial (or circular) in cross section. However, heat sealing may advantageously allow end portions of devices to have a multitude of configurations which may address various needs of a device and its delivery tools. For example, end portions of the device may be square, oblong, rectangular, triangular, or multi-sided. Heat sealing may readily be performed by heat sealing and otherwise flowing material of the ends of a device over mandrels having the shape of the intended configurations. The heat sealing method may advantageously facilitate construction of end portions in such a fashion. The various shapes are intended to be exemplary, and not limiting in the scope of the invention. Similarly, it is possible that alternative methods to fixate, secure or otherwise form the ends of the device may also incorporate the different shaped end portions configurations.

[0237] Treatment devices throughout the descriptions and illustrations contained herein may be described as comprising a single braided or woven body like member, However, it is anticipated that treatment devices may contain multiple braided, woven, otherwise patch-like structures, as illustratively shown in FIGs. 72 and 73. FIG. 72 A shows a treatment device **600'** which may be constructed of two bodies **600**, each of which may appear similar to a device shown elsewhere in the description. The form of treatment device **600'** may advantageously allow a treatment device to occupy, in use, a dimension which is greater along a plane than another plane, as shown in FIG. 72B were device **600'** is depicted in its deployed configuration. In another illustrative example of

multiple braided, woven or otherwise patch-like members comprising a treatment device, inner **642** and outer members **644** of braided, woven or patch-like materials are affixed **646** in the form as shown in FIG. 73A-73C. FIG. 73A shows a side view of device **600**. FIG 73B shows a cross sectional view of device **600**, comprising inner body **642** and outer body **644**. FIG 73C illustratively depicts a form of device **600** as constructed in FIG 73A and 73B in its deployed configuration, advantageously achieving a larger radial profile than device body **642** alone. The devices bodies exemplified in FIGs. 72 and 73 may be affixed through heat sealing, adhesively bonding, sewing, stitching or other various means to attach multiple braided, woven, otherwise patch-like structures together. The use of multiple body members, and any resulting beneficial outcomes, above and herein are intended to serve as examples to altering the construction a treatment device, although, they are only intended to serve as examples, and should not be considered exhaustive of the advantages of employing multiple braided, woven, patch, otherwise mesh-like structures to treatment device.

[0238] With regards to introduction, delivery, deployment and/or fixation of fixation element **308** as described previously and in particular, with regards to FIGs. 47-56, for example, anchor band assembly **308** and its associated delivery tool **400** may be described as effecting a fixation as shown in FIG. 75A and B. FIG. 75A shows a pledget element **309** that, initially, may be placed on outer annular surface. As depicted, tether **318** is attached to pledget **309**, and pledget and tether are secured to suture line **310** via a slip knot **440**, for example. During deployment, T-anchor is drawn toward, and engaged with, treatment device **600** as illustrated in FIG. 75B. There may be alternative methods and mechanisms of drawing together locking elements/anchors **309** and **316**, as exemplified in FIG. 74. FIG. 74 illustrates a T-anchor member **316** that may be positioned, initially, in proximity of patch **600**. As depicted, tether **318** is attached to T-anchor, and T-anchor and tether are secured to suture line **310** via a slip knot **440**, for example. During deployment, pledget **309** may be drawn to, and engage with, the surface of outer annulus tissue, as illustrated in FIG. 75B. The description of methods of drawing members together and effecting a fixation of an fixation element with its

fixation element delivery tools are intended to be illustrative, and not limiting in the scope of the invention.

[0239] Since the surgeon's visualization of during discectomy procedures is typically limited to the epi-annular space and the aperture at the outside surface of the annulus, any tactile, visual or audible signals to assist, or otherwise enhance, the surgeon's ability to reliably deliver and deploy treatment devices and/or anchor bands may be advantageous. The anchor band delivery tool **400**, may have a patch detection feature **442** on the distal end of slotted needle cannula **428** which may provide perceptible feedback (tactile and/or audible) to the surgeon that the anchor band delivery tool has accessed and penetrated the patch and it is therefore acceptable to deliver the band. As shown, detection feature **442** is composed of multiple bands or ribs although the outer surface of needle **428**. The movement of the ribs of **442** against the patch structure (e.g., the filaments of treatment device **600**) may produce a clicking sound and feel, and the interface of the components of the devices and tools may be optimally designed to enhance such feedback features. One, or multiple, ribs or tabs may be utilized to achieve the perceptible features. The feed back may be perceived on or with the patch and/or patch delivery tool or through the anchor band and/or anchor band delivery tool, or both. FIGs. 70A-70C illustratively shows additional means that may be attached to the anchor band or anchor band delivery tool which might also provide perceptible feedback. These depictions are meant to be illustrative and not limiting in scope of the invention. FIG. 70A shows a tab **442** attached to needle cannula **428** which may be laser cut from the distal end of needle **428**. Detection tab **442** may be designed to readily pass through soft tissue and the patch **600** without causing significant disruption, but may be capable due to its design construction to produce tactile and/or audible sensation as it engages the patch lattice or structure. Lateral extent of tab **442** of FIG. 70A may advantageously deflect, or otherwise deform or bend toward the distal end of needle cannula upon removal of the delivery tool so as not to be restricted by the lattice or structure of treatment device **600** upon its removal. Alternatively, detection tab **442** of FIG 70B is affixed to, or integral with, T-anchor **316**.

Similarly, detection tab **442** may be designed to readily pass through soft tissue and treatment device **600** without causing significant disruption, but may be capable of producing tactile and/or audible sensation as it engages the patch lattice or structure. In this embodiment, tab **442** advantageously remains with T-anchor **316** after removal of delivery tool **400**. Moreover, it is possible to have a detection feature **442** as depicted in FIG. 70C wherein the feature is wholly, or partially, coaxial disposed on the delivery tool and feature **442** may be of a construction that does not readily pass through patch **600**, but it is capable of passing through soft tissue of the disc and produce a tactile and/or audible sensation as it engages the patch lattice or structure. Although some of the embodiments illustrate a single tab or rib, it is possible to use more than a single element. Detection features described herein may be of a variety of shapes and affixed to the devices or delivery tools (for example, welding ribs onto the surface of the delivery tool, affixing a flexible filament member to the T-anchor) or be incorporated as an integral component thereof (for example, laser cutting or stamping tabs out of a portion of needle **428**, injection molding tabs as part of t-anchor **316**). Exemplary materials that could be used to construct the various detection features include, but are not limited to: biocompatible polymeric materials (polyester, polypropylene, polyethylene, polyimides and derivatives thereof (e.g., polyetherimide) , polyamide and derivatives thereof (e.g., polyphthalamide), polyketones and derivatives thereof (e.g., PEEK, PAEK, PEKK), PET, polycarbonate, acrylic, polyurethane, polycarbonate urethane, acetates and derivatives thereof (e.g., acetal copolymer), Polysulfones and derivatives thereof (e.g., polyphenylsulfone) , or biocompatible metallic materials (stainless steel, nickel titanium, titanium, cobalt chromium, platinum and its alloys, gold and its alloys).

[0240] As discussed previously, a patch/stent/mesh/treatment device such as treatment device **600** may have element **608** to facilitate the fixing of the patch or its ends in a final deployed configuration, if required. In one exemplary embodiment as shown in FIGs. 29 and 30, a suture with a knot is used to secure ends together after deployment. There may be a variety of ways to latch, lock or

otherwise secure the treatment device in its final configuration, as further depicted in FIG. 71A-G. The drawings and description are intended to be illustrative and not limiting in scope of the invention. It is also anticipated that delivery device tools may need to be altered or otherwise reconfigured in order to accommodate the various latches described. FIG. 71A depicts a latching mechanism that principally involves “press fitting” distal portion/end **606** of treatment device **600** and proximal portion/end **604** of treatment device **600** onto latching element **608**. FIG. 71B shows a “barbed” latching element, wherein proximal end **604** passes over the barb to fixate treatment device in its final configuration. FIG. 71C shows an additional slot **618** placed in barbed latch of FIG. 71B to facilitate the flexing of latch **608**, to accommodate passing end portion **604** over the proximal end of the latch and latching. FIG. 71D shows an embodiment of a latching device that incorporates a washer **610** to pass over the barbed **616** portion of latch **608** to effect the latching and securing the device in its deployed configuration. In addition, FIG. 71E shows an exemplary embodiment in which a “flared” region **620** is created by the patch delivery tool, or other tool, after the proximal end of the patch **604** has been passed onto the latch. FIG. 71G shows an alternative method and device for latching the patch together incorporating a deformable latching mechanism. In step one of FIG 71G, inner latching member is drawn out as indicated by the arrow **622** to readily allow mesh proximal end **604** to be slidably moved along the latching member **608**. Once patch is advantageously positioned in its final configuration, latch member tension is released, lockingly fixing **604** in closer proximity to distal end **606**. Optionally, a latch member cutting tool may be integral to the patch delivery tool to cut latch member **608** to size as shown in step three in FIG. 71G (i.e., resect proximal portion of the latch member in close proximity to proximal end), or if present may be cut with other available tools after delivery of the treatment device.

[0241] The latching or securing embodiments described above principally show the locking effected at, around, or near the proximal portion of the treatment device. However, it is equally anticipated that these locking embodiments could be effected on the distal portion of the treatment device, or at both ends

simultaneously, as shown in FIG. 71F wherein both ends of the device are drawn together and locked with separate parts of a two part, or multiple piece, locking mechanism **608**.

[0242] Latching elements could be constructed from various biocompatible materials, such as polymeric materials (for example, polypropylene, polyimide, polyamide, PEEK, polyester, PET polycarbonate urethane, PTFE, polyethylene, engineering plastics), metallic materials (for example, stainless steel, titanium, chromium cobalt alloy, nickel titanium alloy, platinum, gold), bioresorbable or biodegradable materials (for example, material discussed previously for patch or suture materials), natural materials (for example, silk, cotton), or a combination of above materials.

[0243] Figures 76 and 77 further illustrate an additional embodiment of the invention wherein the device may be used to repair an aperture within the intervertebral disc in conjunction with a nuclear augmentation procedure. The augmentation of the intervertebral disc nucleus may include partial or complete removal of the disc nucleus and possibly portions of the annulus and other spinal tissues, depending on the design of the implant. The prophylactic and/or therapeutic objective of these nuclear augmentation implants is to help maintain and/or restore the normal or natural function of the spinal disc, as described for example in U.S. Patent No. 5,976,186 (Bao et al.). The surgical repair of an intervertebral disc may require the removal of the entire disc nucleus being replaced with an implant or a portion of the disc nucleus thereby leaving a void in the intervertebral disc cavity. The volume of nuclear replacement added to the subannular cavity may be less than, equal to, or larger than disc tissue volume removed. The volume of the implant may vary over time, depending on the type of replacement or augmentation device implanted. Although previous embodiments of the invention described herein could be used to contain implant materials within the disc space, FIG. 76 and FIG. 77 illustrate embodiments that may more readily accommodate the introduction of injectable, or otherwise flowable, materials into the disc space. Preferably, the materials would be in situ curable (by way of a number of methods, for example, chemical, thermal, or

photoinitiated), although it is not necessary that they are. For example, one could introduce a nucleus augmentation implant comprising small hydrogel particles in an aqueous suspension that could be delivered to the disc space, with the annular repair patch **600** retaining the intradiscal material within the disc space. Figures 76B and 77 are depicted with nuclear augmentation material **218** being introduced into the disc space. Figure 76A shows a cross section view of the delivery of a flowable material **218** from the distal end of delivery device **500** as shown by arrow 220. The nuclear replacement may be introduced through the cannula **526** (as shown in FIG. 58 with rod **514** removed) or another cannula of **500**, such as **522**. As further illustrated in Figure 76B, the nuclear augmentation material flows, in use, from the distal end of the delivery tool as shown with arrow **220** and into the intervertebral disc space. FIG. 77 illustrates an alternative method and device for the introduction of material **218** into the disc space via the fixation element delivery tool **400**. The nuclear augmentation material is injected and flows from the needle cannula of tool **400** as shown by arrow **222**, although, other cannulae of tool **400** might also be advantageously used to deliver material **218**, such as cannula **426**. As an alternative embodiment, using cannula **426** as a delivery conduit, needle cannula **428** may be advantageously be retracted as described above, prior to, during, or after the delivery of material through conduit **426**. In the embodiments described, flowable and/or injectable material is introduced into the disc space and the annular treatment device acts to avoid, restrict or otherwise reduce the possibility of the implanted material from extruding or migrating from the subannular space. It is contemplated that one could adapt the delivery tools' construction to accommodate specific characteristics of a variety of augmentation materials, therefore the construction of the delivery tools as depicted are meant to be illustrative, and not limiting.

[0244] Flowable, injectable, or otherwise insertable nuclear augmentation materials might include natural or synthetic materials comprising: hydrogels, polymers, polymeric precipitates, polymeric emulsions, collagen, fibrin, polymeric protein compositions, poly vinyl alcohols, polysaccharides, cellulose or any derivations of these materials.

[0245] As discussed previously, FIGs. 76 and 77 are illustratively intended to depict the introduction of nuclear replacement material **218** to the intervertebral disc, although they may also exemplify methods and devices to delivery adhesive materials. It is also contemplated that additional membrane material may be added to the treatment device to further help restrict extravasation of material out of the disc during augmentation delivery, if required. Conversely, the treatment device construction may be altered to reduce the mesh porosity in order to accomplish a similar objective. Furthermore, it is anticipated that materials maybe added to, or changed, on portions of the delivery tools to facilitate delivery of the material and removal of the delivery devices after implant introduction. For example, cannula **526** in FIG. 76 may be coated with, or be constructed of, PTFE, FEP, polypropylene, polyethylene or other lubricious materials or coatings. Similarly, portions of delivery device **400** in FIG. 77 may have similar material treatments to accomplish the same objective.

[0246] As described above, there are a variety of instruments and tools readily available to the surgeon during spine surgery, or other surgical procedures, to obtain outcomes intended by the surgeon and the surgical procedure. These tools and instruments may be used to: incise, resect, dissect, remove, manipulate, elevate, retract, probe, cut, curette, measure or otherwise effect a surgical outcome. It is anticipated that some of these tools and/or instruments may be used before, during, or after the use of the inventive methods, devices and tools described herein in order to access, prepare, and/or generally assess treatment, treatment site, or facilitate the manipulation, introduction, or deployment of the treatment device and/or it's components. Additional tools and instruments may also be provided to the surgeon to address some of these functions. FIG. 65 illustrates one such tool, wherein sizing tool **626**, with handle **628** used for tool manipulation, is placed within the subannular cavity to probe the subannular space and generally assess the treatment site prior to delivery of patch, anchor bands or other treatment devices. Generally the length of the device from the tissue stop **634** to the distal end **630** of tool **626** could allow a physician to measure, or otherwise assess the depth of the cavity

and assure sufficient space available as not to cause any untoward events as a result of introduction of the treatment device or its delivery tools. Additional markers **636**, preferably radiographically enhanced, may be placed along distal end of tool to provide indication of the relative components of the treatment device and/or its delivery tools. For example, as shown, two markers may identify where the distal and proximal ends of treatment device may be situated, after deployment, of the patch. This may be performed prior to introduction of treatment device to the cavity. Proximal end may advantageously contain other functional instruments, helping the surgeon to otherwise manipulate, resect, probe and/or assess the cavity or surrounding tissues, such as a angled curette, as shown in FIG. 65. It is anticipated that instrument **626** could be provided as a disposable tool, or a re-sterilizable instrument. The tool may be advantageously constructed of biocompatible metallic materials or polymeric materials, or a combination of both. As an example, the handle and general construction of the instrument may be formed from a polymer such as: polyester, polypropylene, polyethylene, polyimides and derivatives thereof (e.g., polyetherimide), polyamide and derivatives thereof (e.g., polyphthalamide), polyketones and derivatives thereof (e.g., PEEK, PAEK, PEKK), PET, polycarbonate, acrylic, polyurethane, polycarbonate urethane, acetates and derivatives thereof (e.g., acetal copolymer), polysulfones and derivatives thereof (e.g., polyphenylsulfone), or the like, whereas markers **636**, tissue stop **634**, distal **630** and proximal ends **632** could be made of metallic materials such as stainless steel, platinum iridium alloys, platinum, titanium, gold, or the like. It is also contemplated that the radiographic components could be deposited (e.g., vapor deposition) or affixed (e.g., tubular bands attached circumferentially) onto the instrument **626**. The description and depiction of tool is intend to illustrative and not limiting in scope.

[0247] Finally, the description and illustrations described previously may be directed and illustrative of various spinal applications of the invention, it is possible that the inventive methods, devices and delivery tools could be applied to the repair, fixation, augmentation, reinforcement, support or otherwise generally prophylactically or therapeutically treating other tissues. As an example, but not

to be limiting the scope of use in other tissues, FIG 79A-79B illustrate a knee joint in transverse section, containing a meniscus of the knee, anatomically positioned above the Tibia bone **652**. The meniscus may be damaged, torn, weakened, delaminated, degenerated, thin or otherwise in need of treatment. Fixation elements and/or treatment devices as described herein, may be deployed within the meniscal tissue to effect a repair as shown in FIG 79B, for example, with two anchor band assemblies **308** drawing together, and repairing defect **750**. It is anticipated within the scope of the invention that methods, devices and/or delivery tools described herein, and their associated materials, may be adapted to accommodate anatomical and physiological characteristics involved in repair of the meniscus.

[0248] An additional example of using the inventive methods, devices and delivery tools described herein for the repair, fixation, reinforcement, augmentation, support or otherwise generally prophylactically or therapeutically treating other tissues is exemplified in FIGs. 80A-80B. FIG. 80A illustrates a general surgical application wherein the contents of the abdomen may urge the peritoneal cavity to pass out of, or through, the femoral ring **660** in proximity of the Inguinal **656** and Lacunar **658** ligaments, and otherwise present with symptoms associated with a femoral herniation. In FIG. 80A, External Iliac Artery **662** and External Iliac Vein **664** are identified for reference purposes. Treatment devices, as described herein, may be delivered and applied to repair the femoral ring area by placing a treatment device just below the femoral ring, and the associated Inguinal and Lacunar ligaments surrounding the femoral ring area. As illustratively shown in FIG. 80B, once treatment device **600** is deployed, one or more fixation elements **308** may be affixed to the patch and the Lacunar and/or Inguinal ligaments to secure the treatment device, thereby reducing the tendency of the abdominal contents to urge through the femoral ring area. It is anticipated within the scope of the invention that methods, devices and/or delivery tools described herein, and their associated materials, may be adapted to accommodate anatomical and physiological characteristics involved in the

augmentation, reinforcement, or otherwise reparation of various femoral, inguinal, umbilical, and incisional hernia.

[0249] All patents referred to or cited herein are incorporated by reference in their entirety to the extent they are not inconsistent with the explicit teachings of this specification, including; U.S. Patent No. 5,108,438 (Stone), U.S. Patent No. 5,258,043 (Stone), U.S. Patent No. 4,904,260 (Ray et al.), U.S. Patent No. 5,964,807 (Gan et al.), U.S. Patent No. 5,849,331 (Ducheyne et al.), U.S. Patent No. 5,122,154 (Rhodes), U.S. Patent No. 5,204,106 (Schepers et al.), U.S. Patent No. 5,888,220 (Felt et al.), U.S. Patent No. 5,376,120 (Sarver et al.) and U.S. Patent No. 5,976,186 (Bao et al.).

[0250] Various materials known to those skilled in the art can be employed in practicing the present invention. By means of example only, the body portions of the stent could be made of NiTi alloy, plastics including polypropylene and polyethylene, polymethylmethacrylate, stainless steel and other biocompatible metals, chromium cobalt alloy, or collagen. Webbing materials can include silicone, collagen, ePTFE, DACRON, polyester, polypropylene, polyethylene, and other biocompatible materials and can be woven or non-woven. Membranes might be fashioned of silicone, polypropylene, polyester, SURLYN, PEBAX, polyethylene, polyurethane or other biocompatible materials. Inflation fluids for membranes can include gases, liquids, foams, emulsions, and can be or contain bioactive materials and can also be for mechanical, biochemical and medicinal purposes. The stent body, webbing and/or membrane can be drug eluting or bioabsorbable, as known in the medical implant arts.

[0251] Further, any of the devices or delivery tools described herein, or portions thereof, could be rendered visible or more visible via fluoroscopy, if desired, through the incorporation of radiopaque materials or markers. Preferably implantable devices are constructed with MRI compatible materials. In particular, devices and/or their components could be wholly or partially radiopaque, as result of, for example: compounding various radiopaque materials (e.g., barium sulphate) into device materials; affixing radiopaque materials to device structures (e.g., bands of platinum, gold, or their derivative alloys);

deposition of radiopaque materials onto device structures (e.g., deposition of platinum, gold or their derivative alloys); processing radiopaque materials into device structures (e.g., braiding/weaving platinum or gold wires or its alloy derivatives). One inventive way to achieve radiopacity of a device described herein, for example treatment device **600**, is placing one or more radiopaque marker bands onto filaments of braided device **600** before (or possibly after) creating end portions of the device.

[0252] Other embodiments of the invention will be apparent to those skilled in the art from consideration of the specification and practice of the invention disclosed herein. It is intended that the specification and examples be considered as exemplary only, with a true scope and spirit of the invention being indicated by the following claims.

Claims

1. A method of treating an intervertebral disc comprising:
providing a first delivery tool having a proximal end and a distal end, the distal end carrying a treatment device;
providing at least one second delivery tool having a proximal end and a distal end, the distal end carrying a fixation element;
introducing the distal end of the first delivery tool at least partially into subannular intervertebral disc space;
deploying said treatment device;
introducing the distal end of said at least one second delivery tool at least partially into subannular intervertebral disc space;
deploying at least one fixation device into, or through, the wall of an annulus to hold said treatment device at least partially within the subannular intervertebral disc space.
removing said at least one second delivery tool;
removing said first delivery tool.
2. A method of claim 1, wherein said fixation device comprises at least one surgical suture.
3. A method of claim 3, wherein said surgical suture material is biodegradable.
4. A method of claim 1, wherein said fixation device comprises at least one anchor portion and at least one band portion.
5. A method of claim 1, wherein said fixation device is formed from biodegradable material or bioabsorbable material.
6. A method of claim 4, wherein said anchor portion comprises at least one T-anchor.

7. A method of claim 4, wherein said anchor portion comprises at least one barb.

8. A method of claim 7, wherein said at least one tip of the at least one barb is formed from biodegradable material.

9. A method of claim 4, wherein said at least one band is formed from suture material.

10. A method of claim 4, wherein said at least one band is formed from wire.

11. A method of claim 10, wherein said at least one wire comprises a nickel titanium alloy or stainless steel.

12. A method of claim 4, wherein the portion of said band that is contiguous with said anchor portion is formed from at least one wire, and the portion of said band spanning said aperture is formed from suture material.

13. A method of claim 12, wherein said suture material is in the form of a mesh tube.

14. A method of claim 12, wherein said suture material has a width greater than its height.

15. A method of claim 1, wherein said fixation device is secured with a knot.

16. A method of claim 15, wherein said knot is pre-tied.

17. A method of claim 1, wherein said fixation device is secured with a band locking device.

18. A fixation device useful for intervertebral disc reconstruction for treating a disc having an aperture, weakened, or thin portion in the wall of the annulus fibrosis of said intervertebral disc, said device comprising:
at least one anchor portion and at least one band.

19. The device of claim 18, wherein said anchor portion comprises at least one T-anchor.

20. The device of claim 18, wherein said anchor portion comprises at least one barb.

21. The device of claim 20, at least one tip of said at least one barb is formed from biodegradable material.

22. The device of claim 18, wherein said at least one band is formed from suture material.

23. The device of claim 18, wherein said at least one band is formed from wire.

24. The device of claim 23, wherein said at least one wire is formed from a nickel titanium alloy.

25. The device of claim 18, wherein said band comprises at least two different materials.

26. The device of claim 18, wherein said band is in the form of a mesh tube.

27. The device of claim 18, wherein said band has a width:height ratio of 1.25:1.
28. A kit for use in treating an intervertebral disc comprising:
a treatment device delivery tool;
at least one fixation device delivery tool.
29. The kit of claim 28 further comprising a sizing tool.

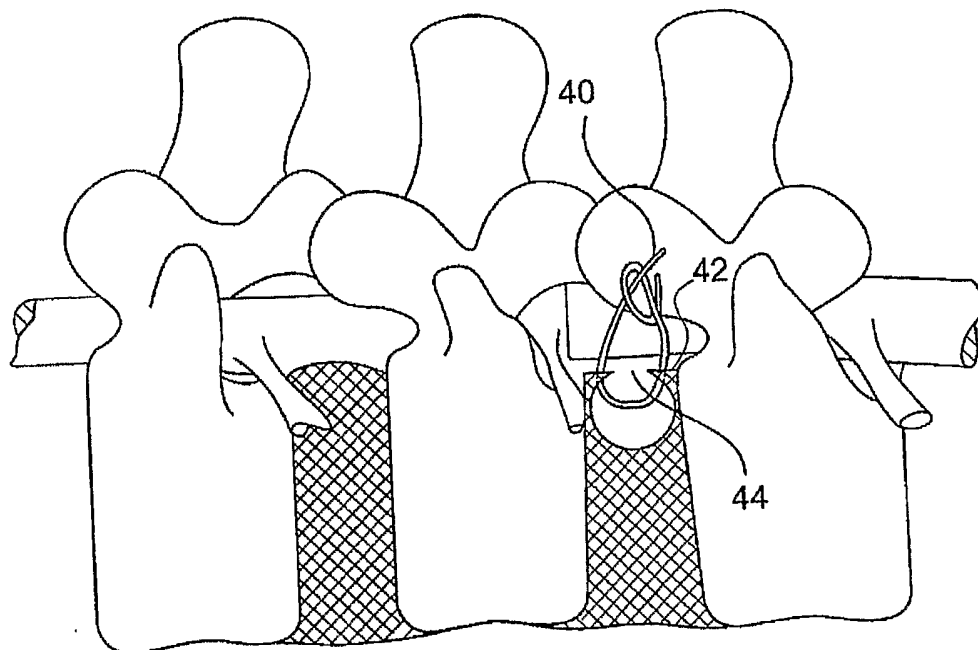

FIG. 1

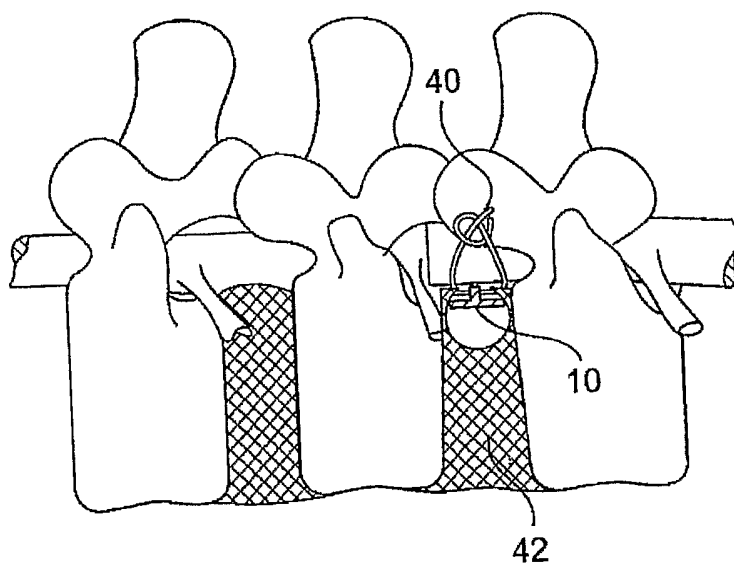

FIG. 2A

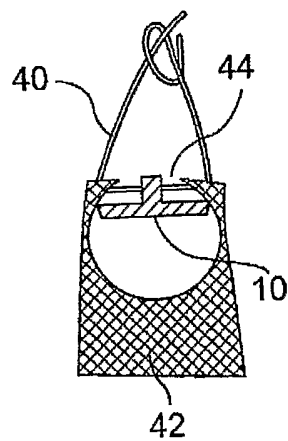

FIG. 2

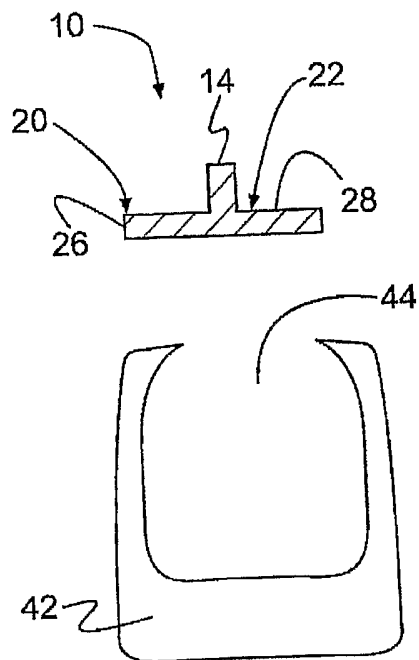

FIG. 3A

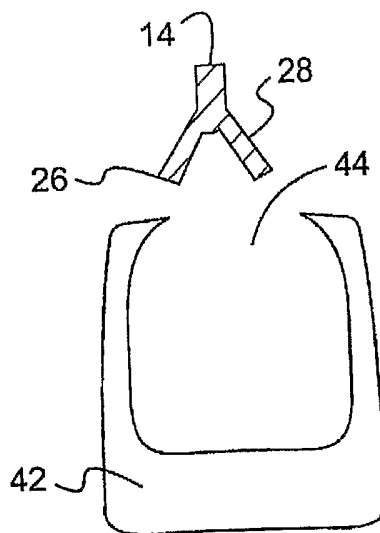

FIG. 3B

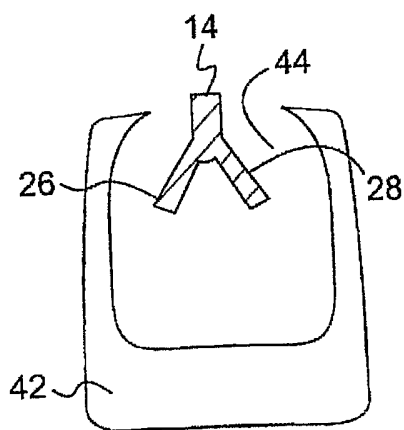

FIG. 3C

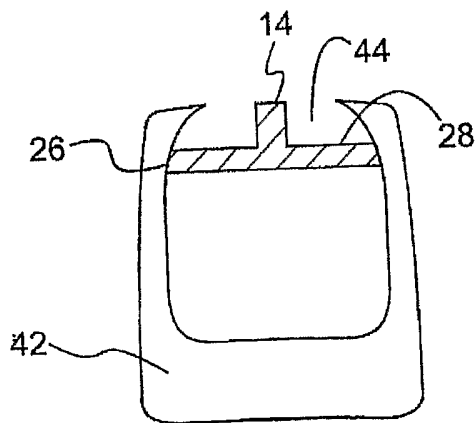
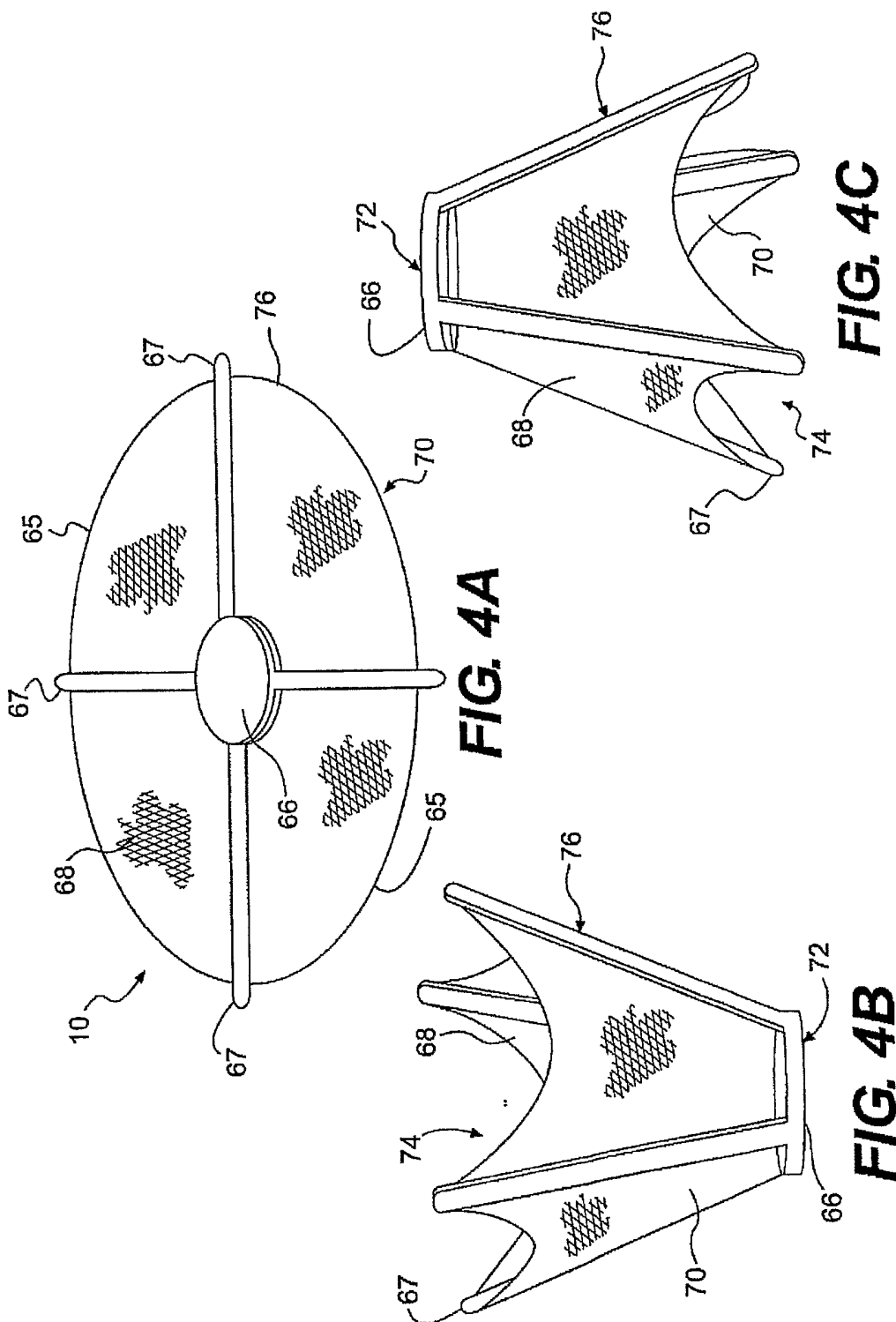
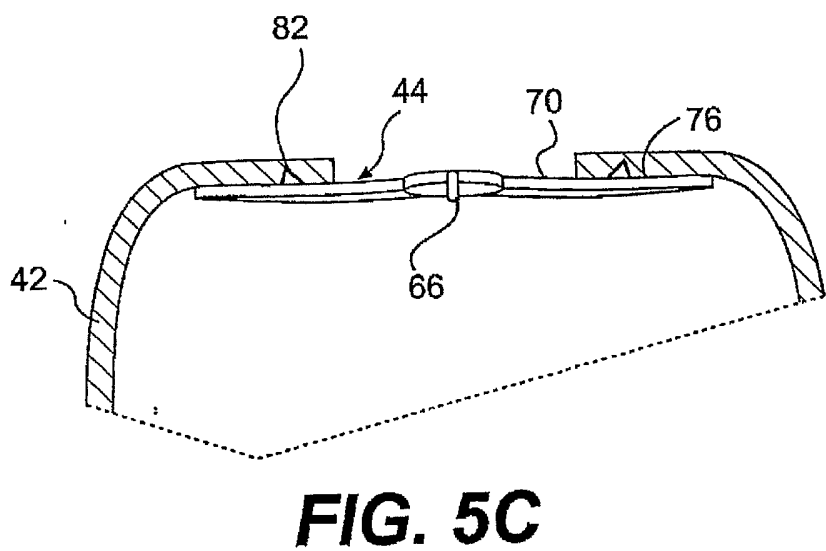
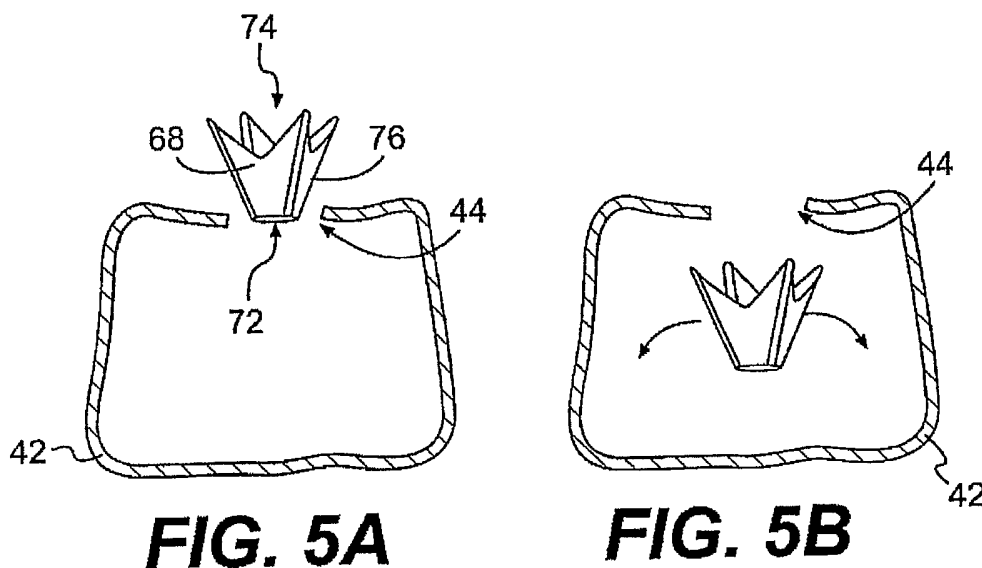

FIG. 3D





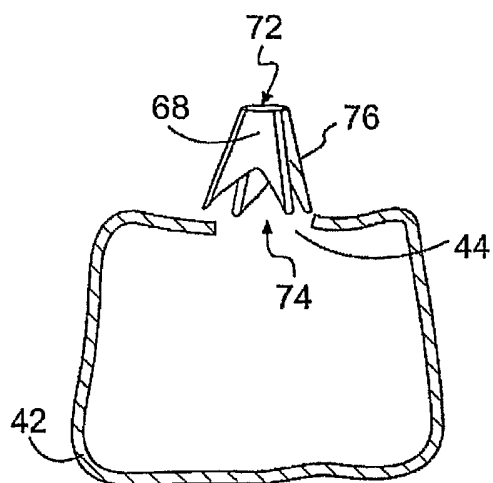

FIG. 6A

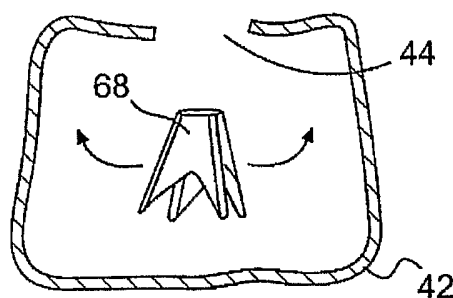

FIG. 6B

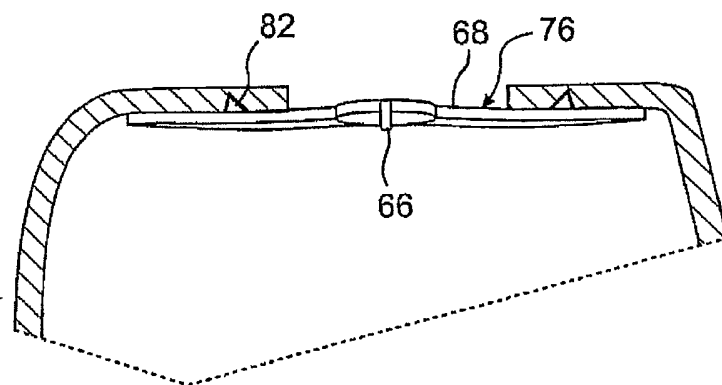
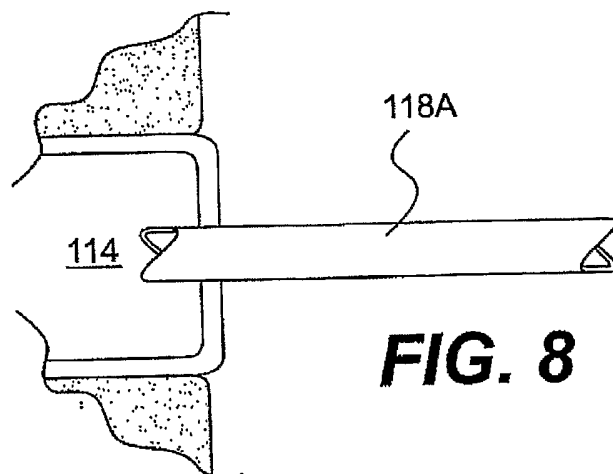
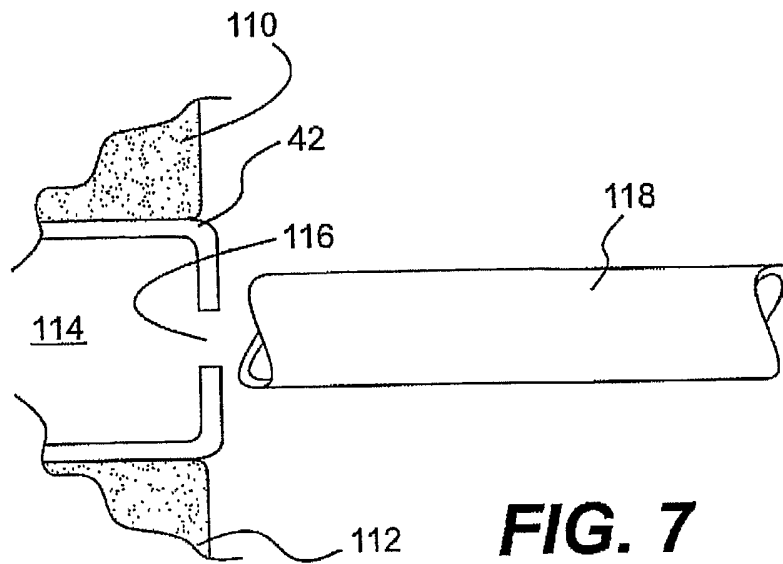

FIG. 6C



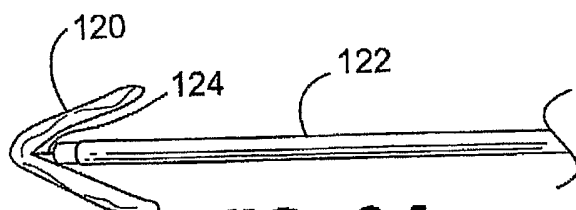

FIG. 9A

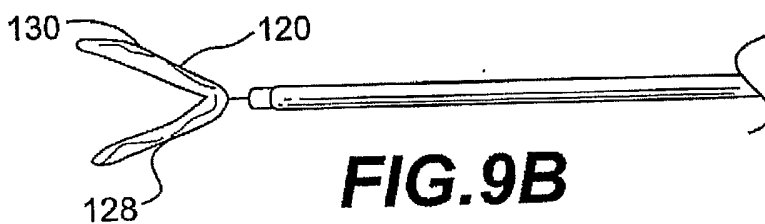

FIG. 9B

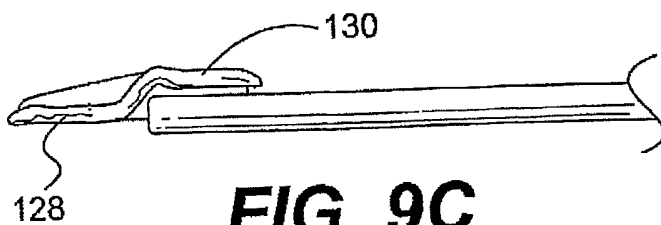

FIG. 9C

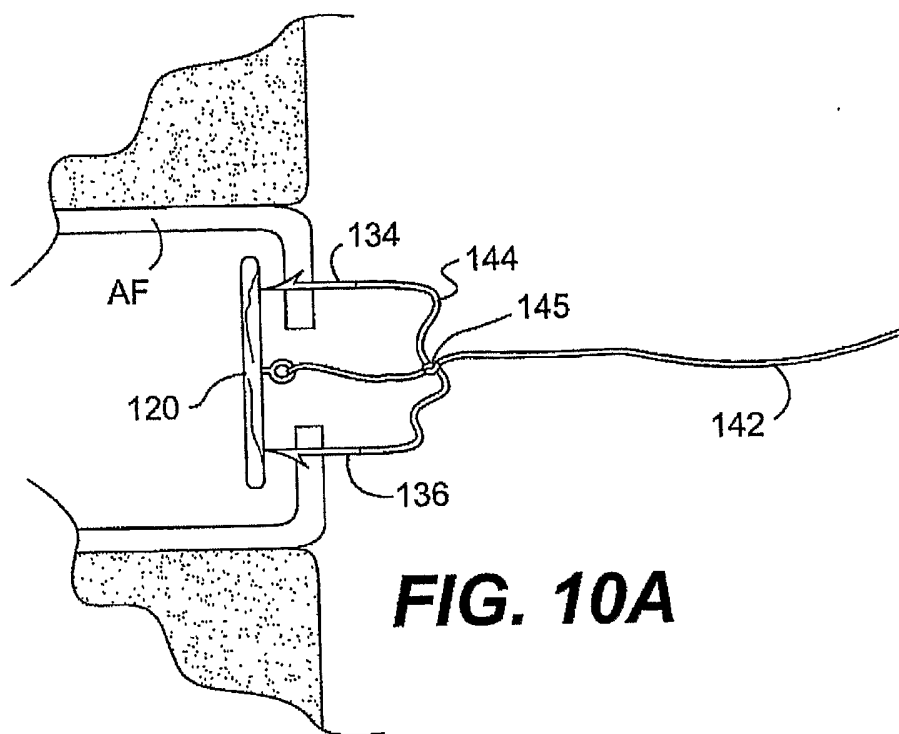

FIG. 10A

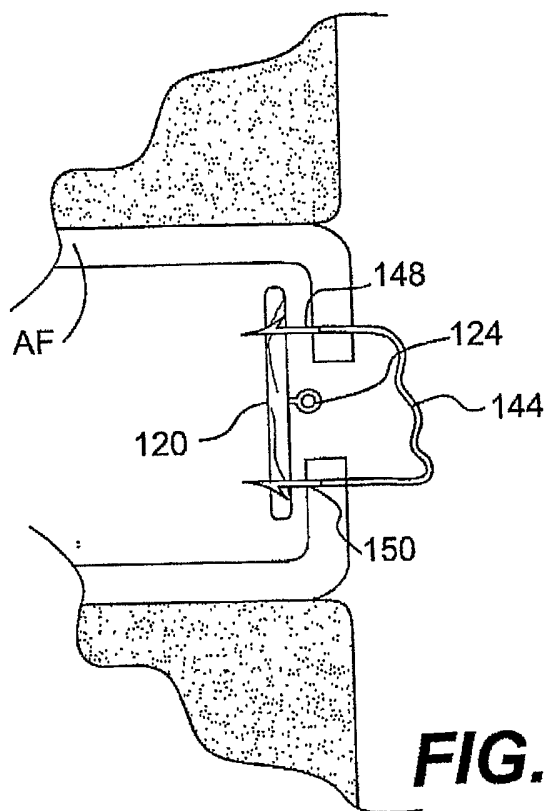
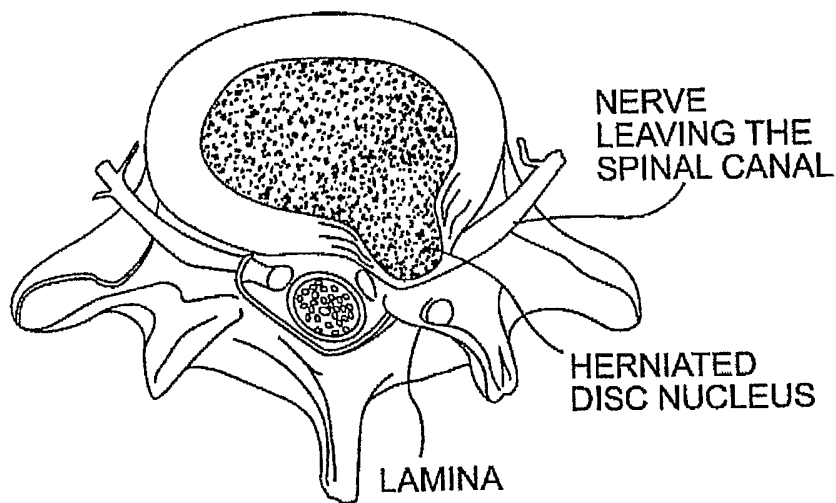
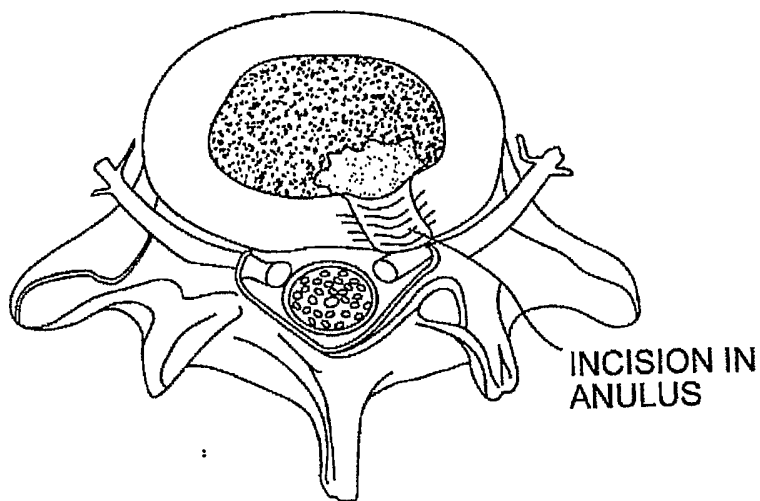

FIG. 10B



HERNIATED DISC

FIG. 11A



DISC, POST-DISCECTOMY

FIG. 11B

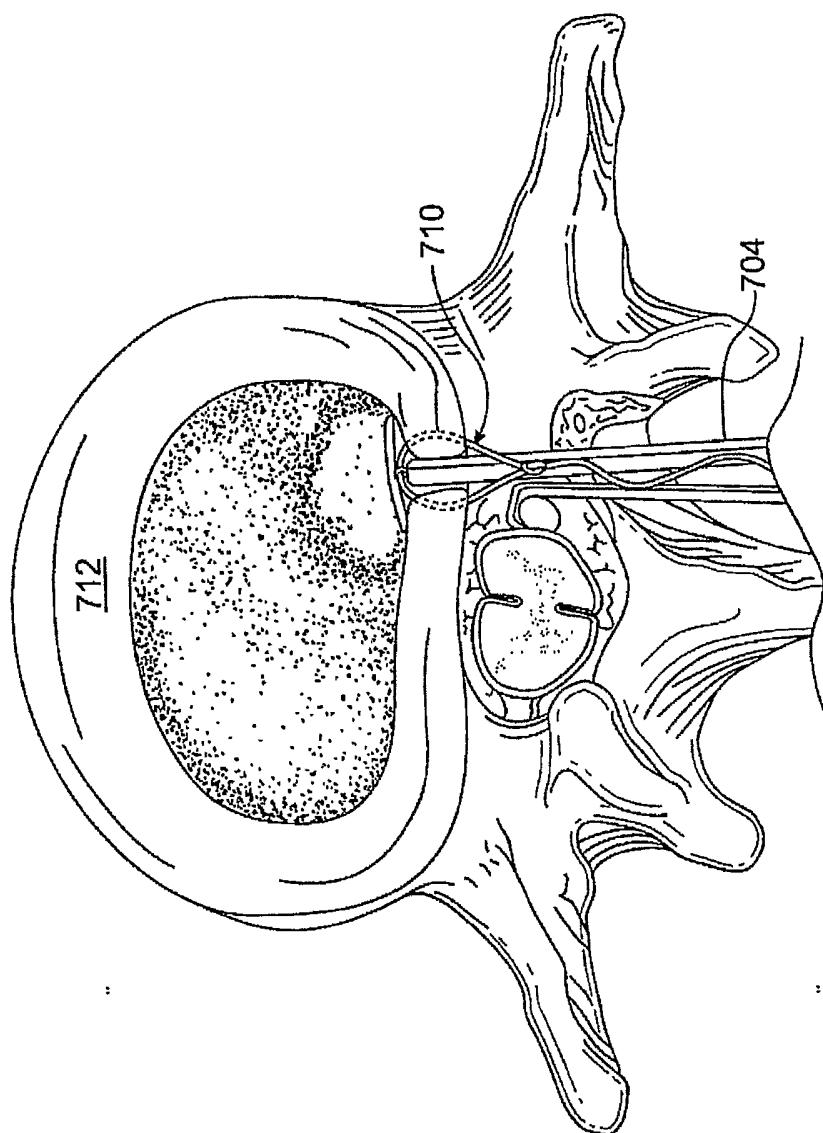

FIG. 12A

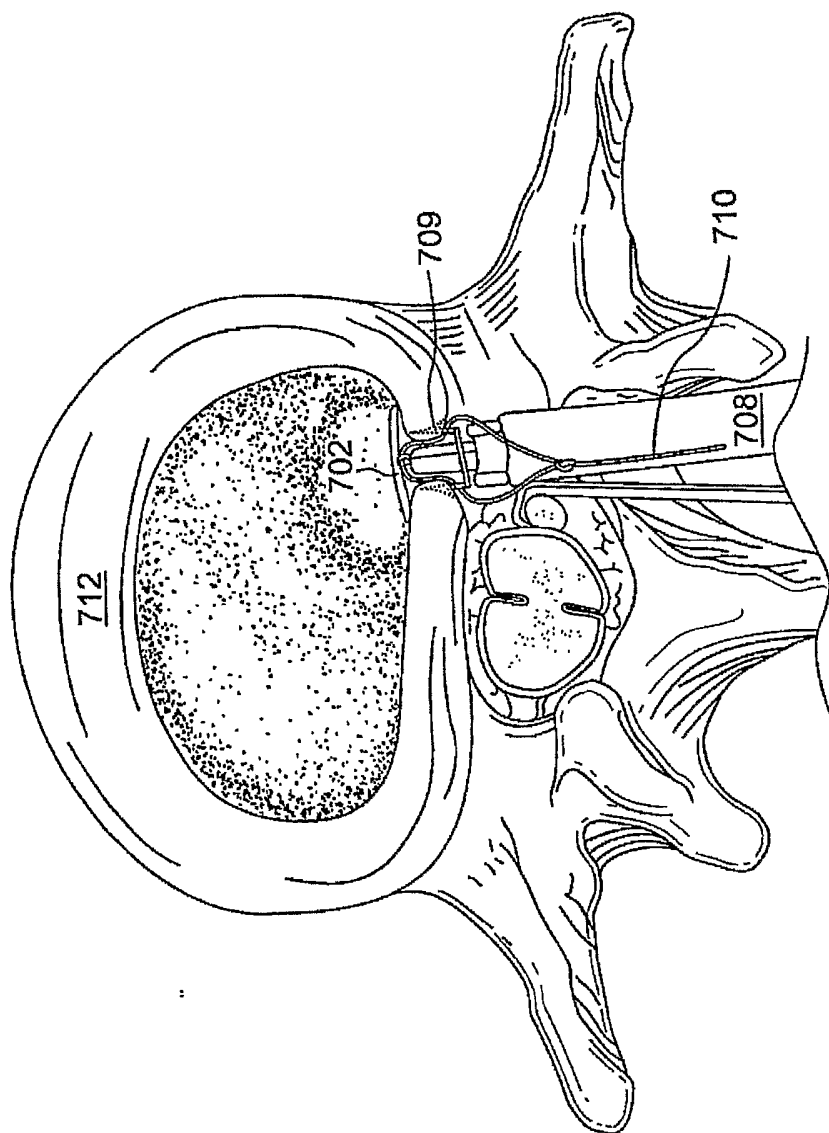

FIG. 12B

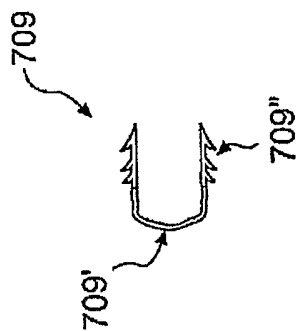

FIG. 12D

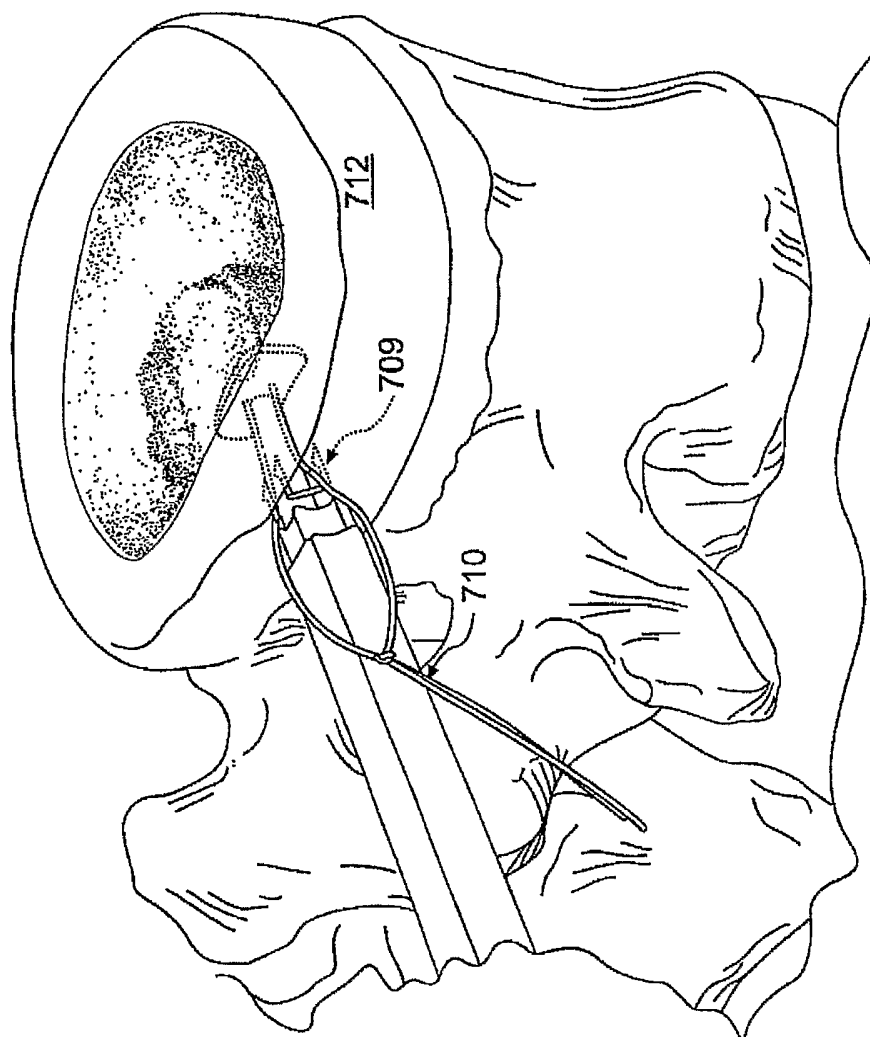

FIG. 12C

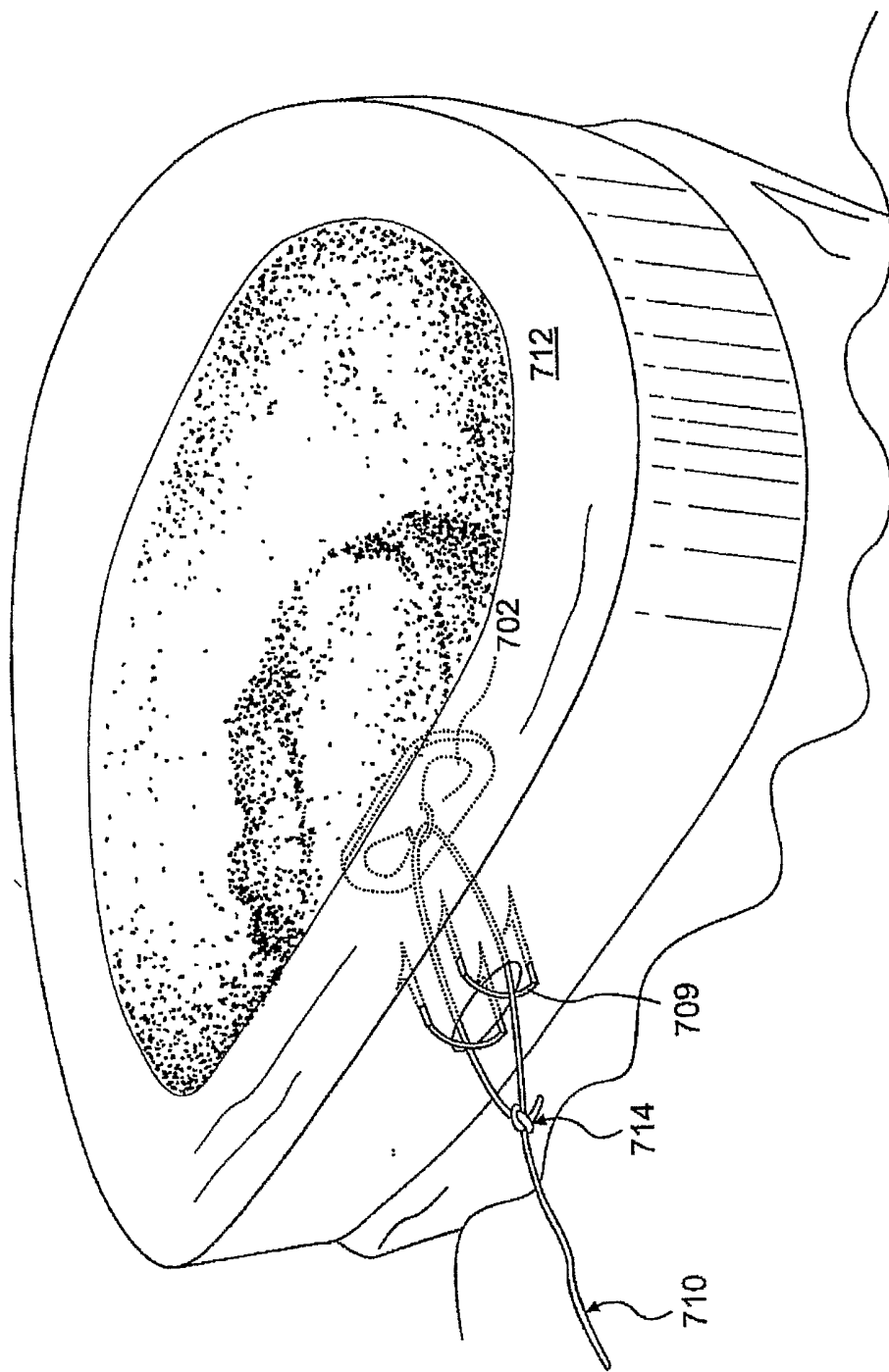

FIG. 12E

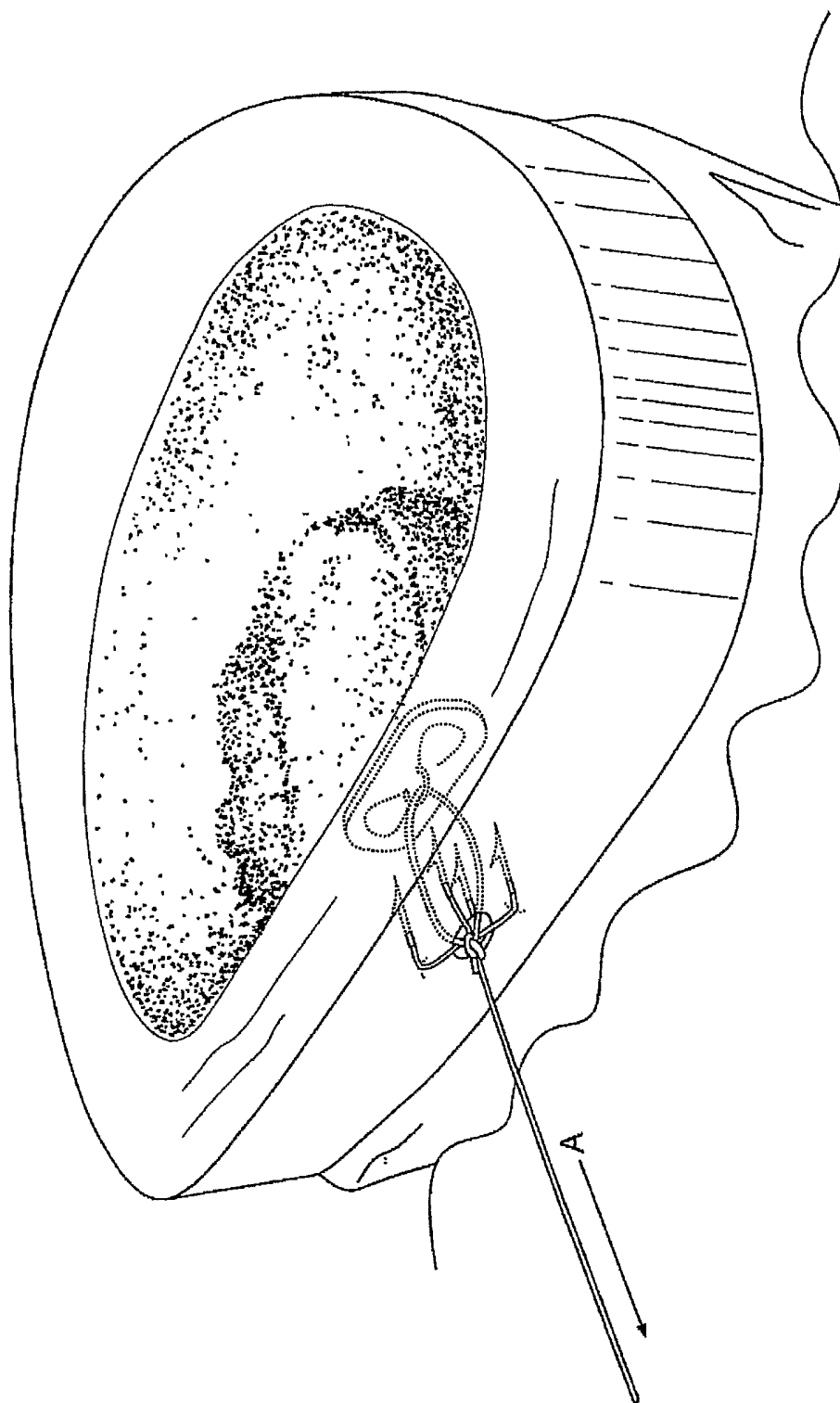

FIG. 12F

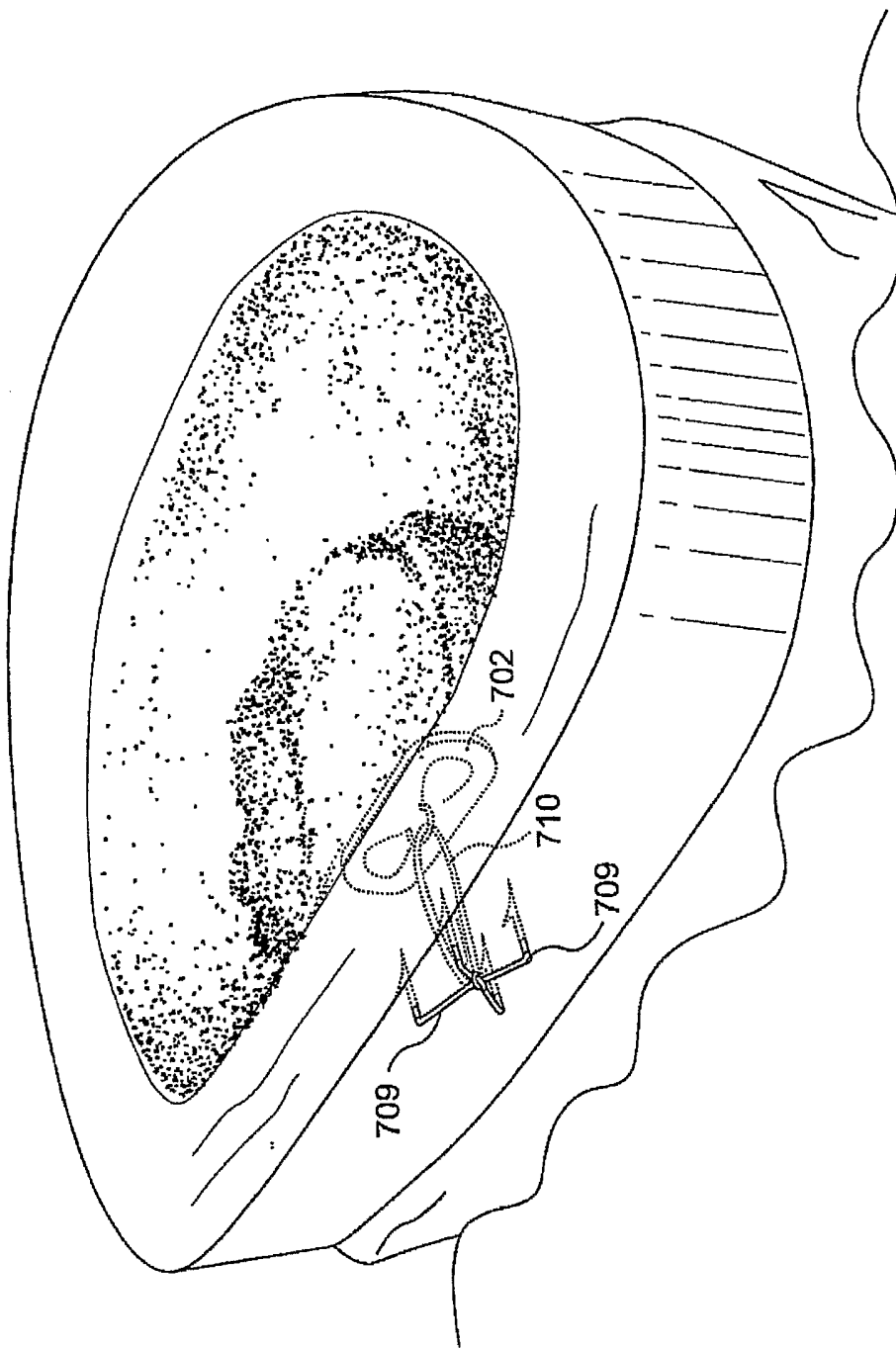

FIG. 12G

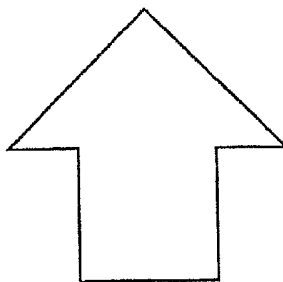
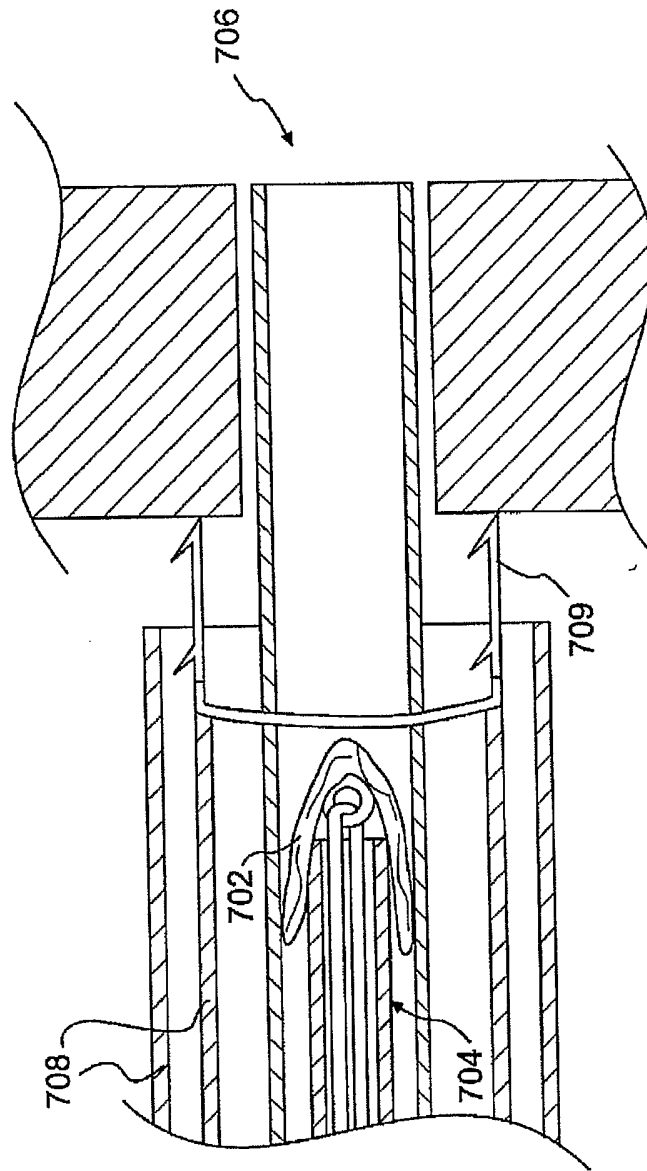

FIG. 13A

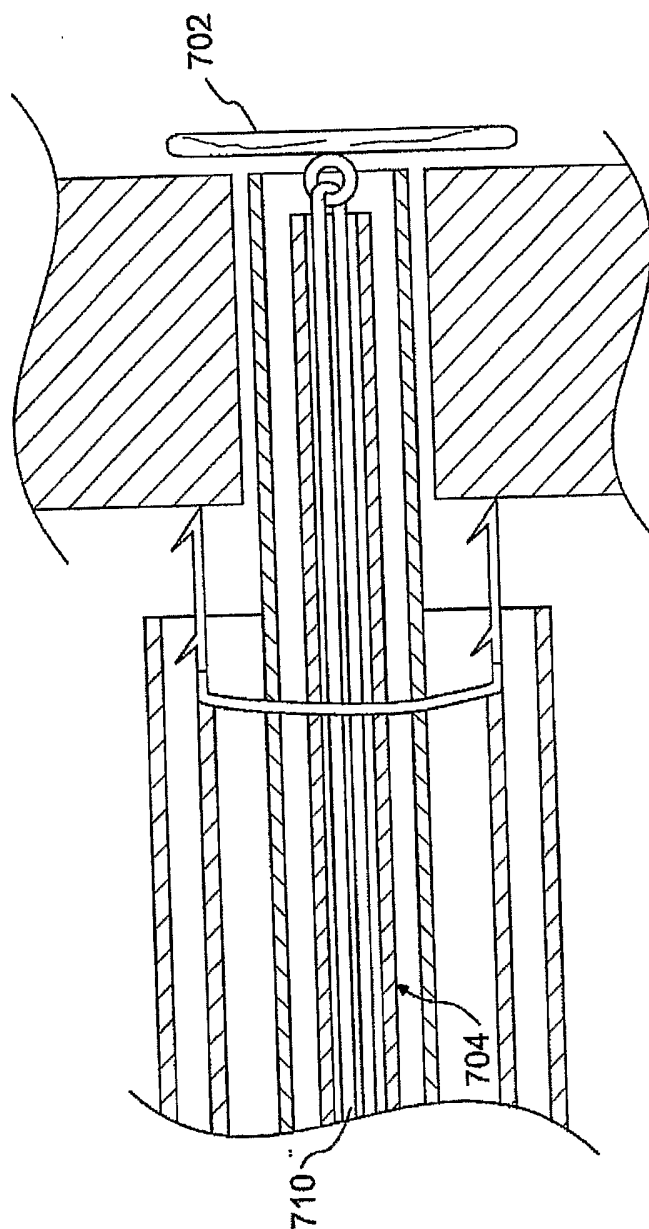

FIG. 13B

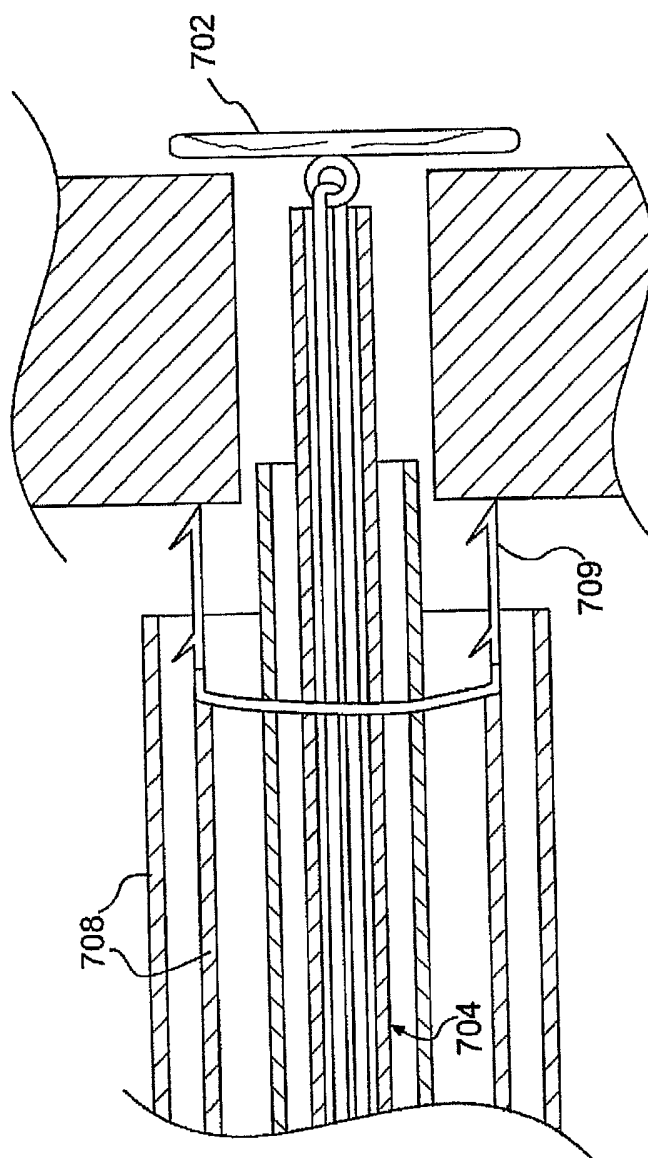

FIG. 13C

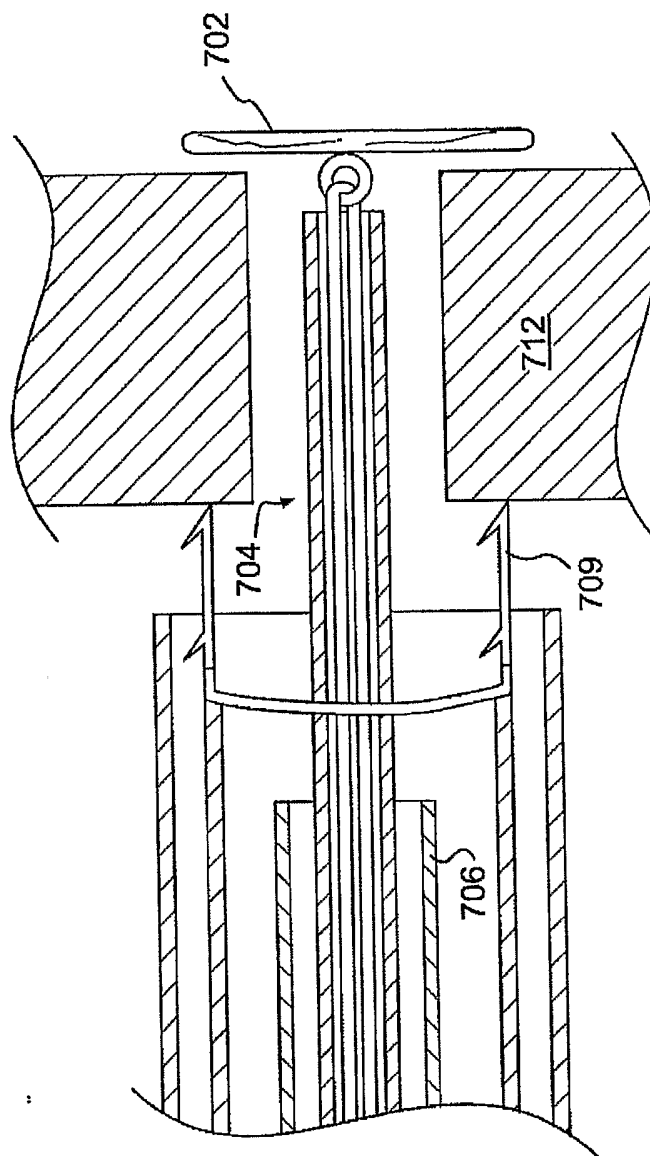

FIG. 14A

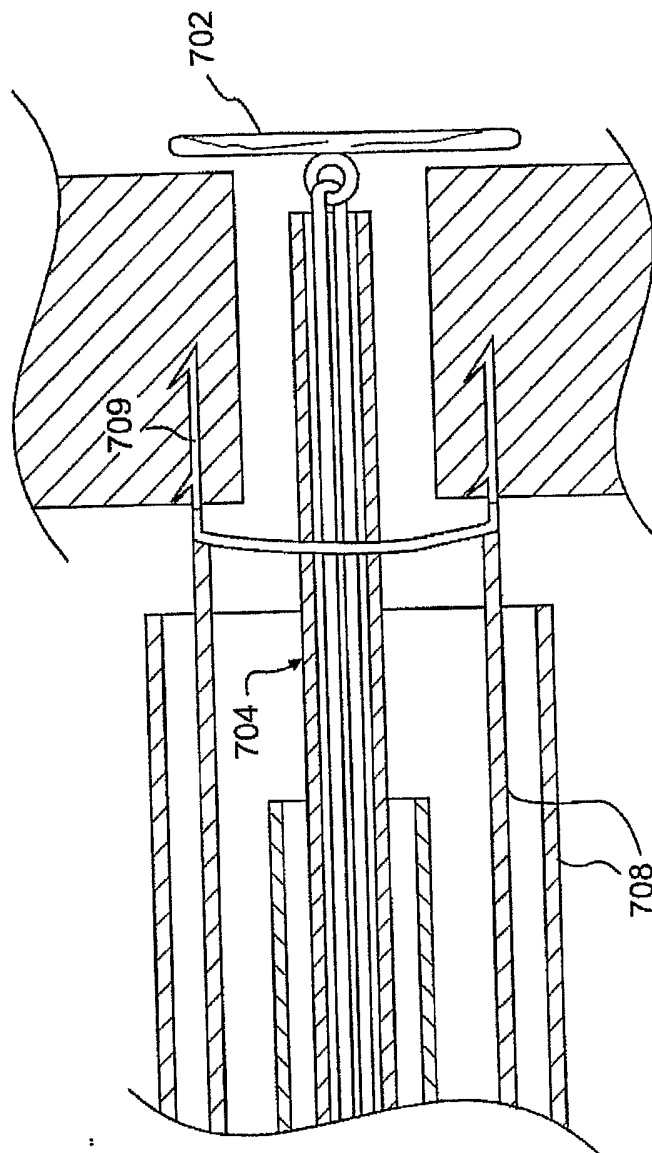
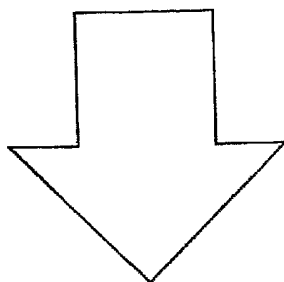

FIG. 14B



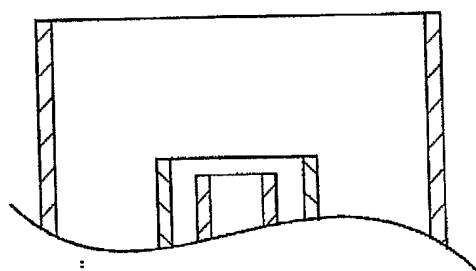
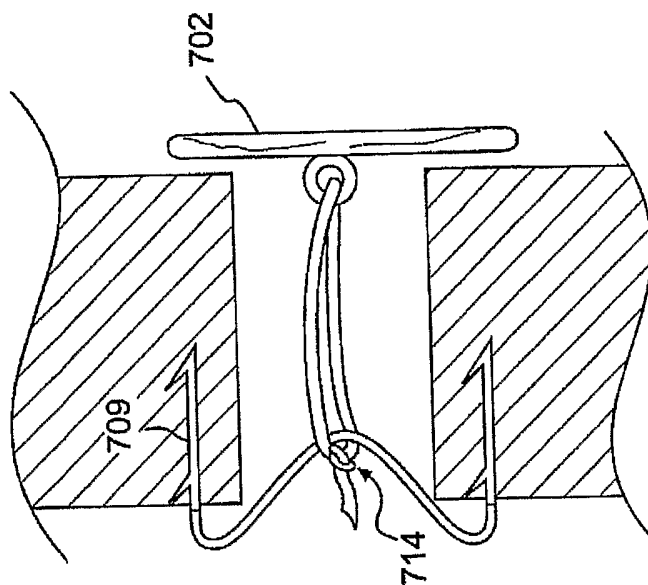

FIG. 14C

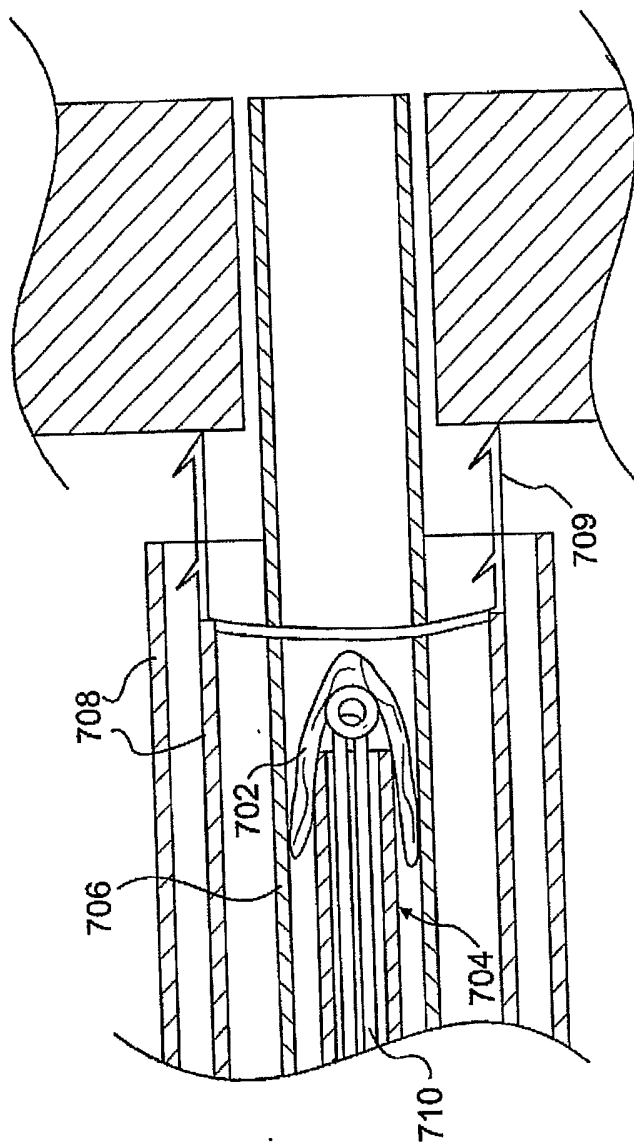
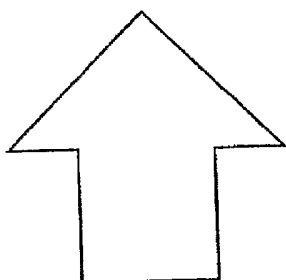

FIG. 15A



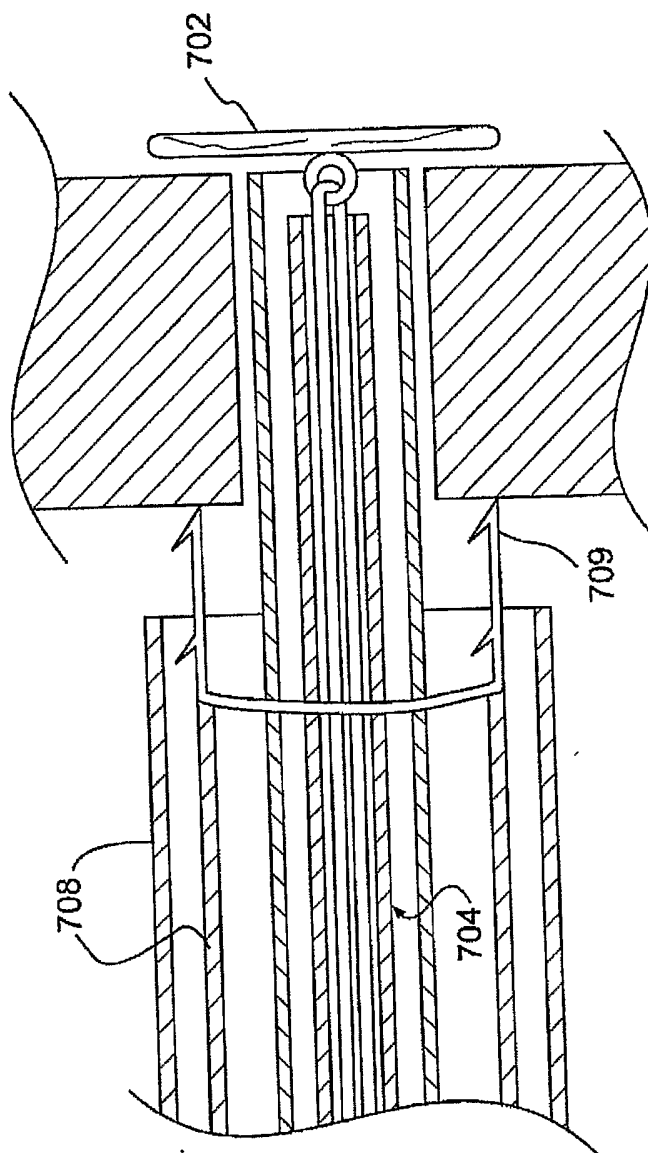

FIG. 15B

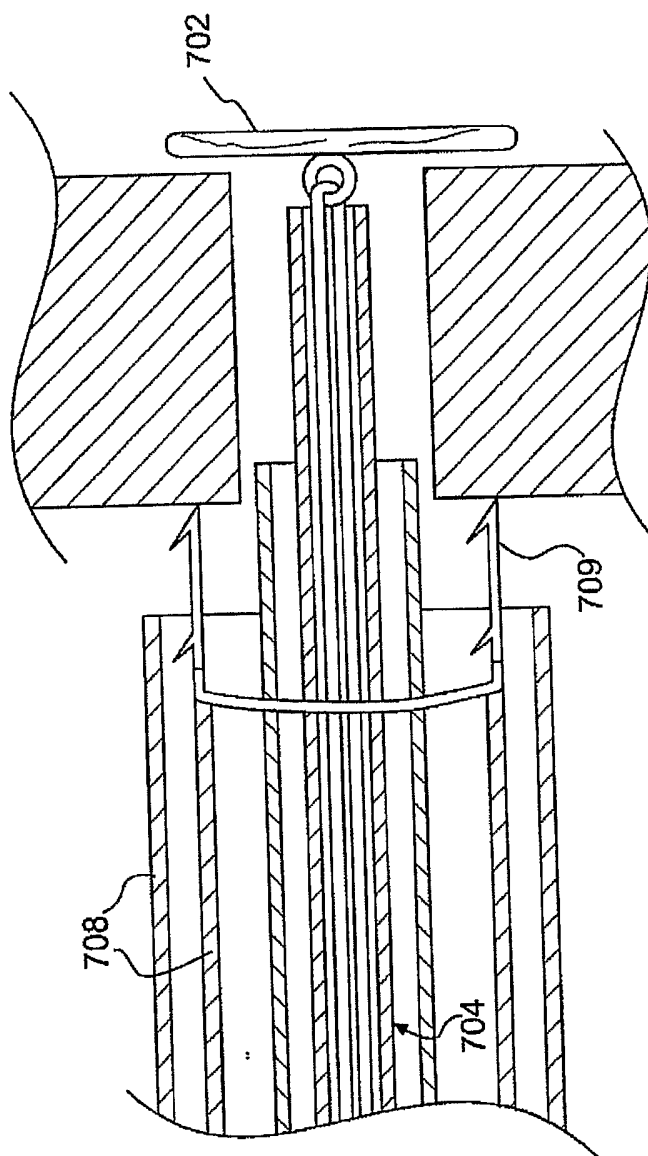

FIG. 15C

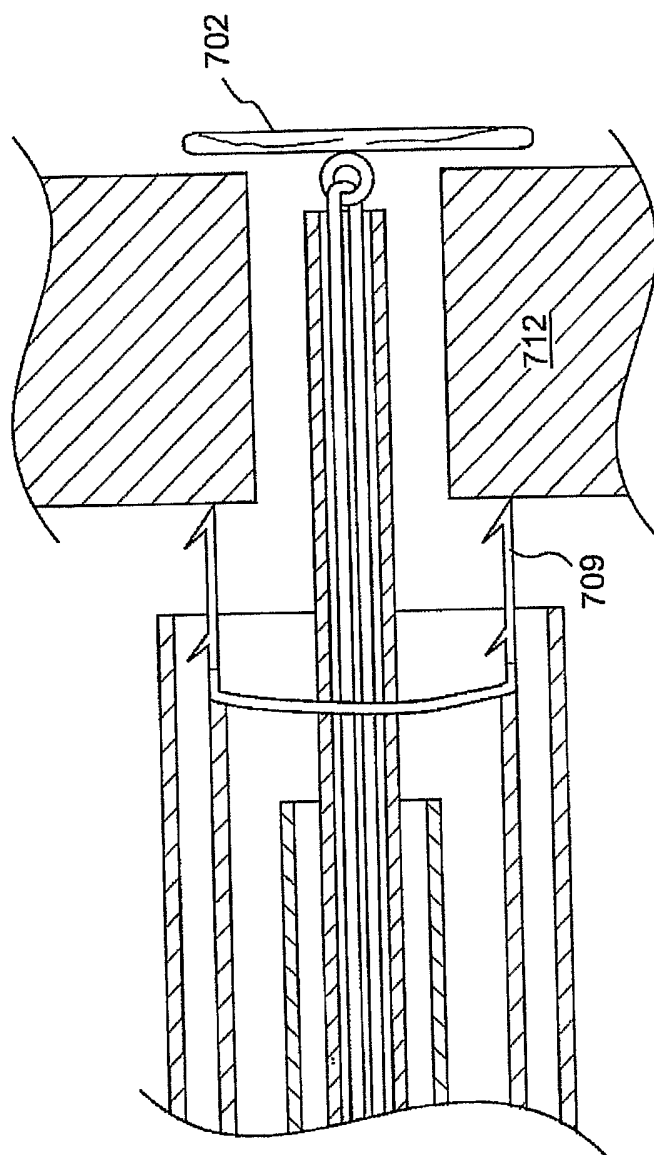

FIG. 16A

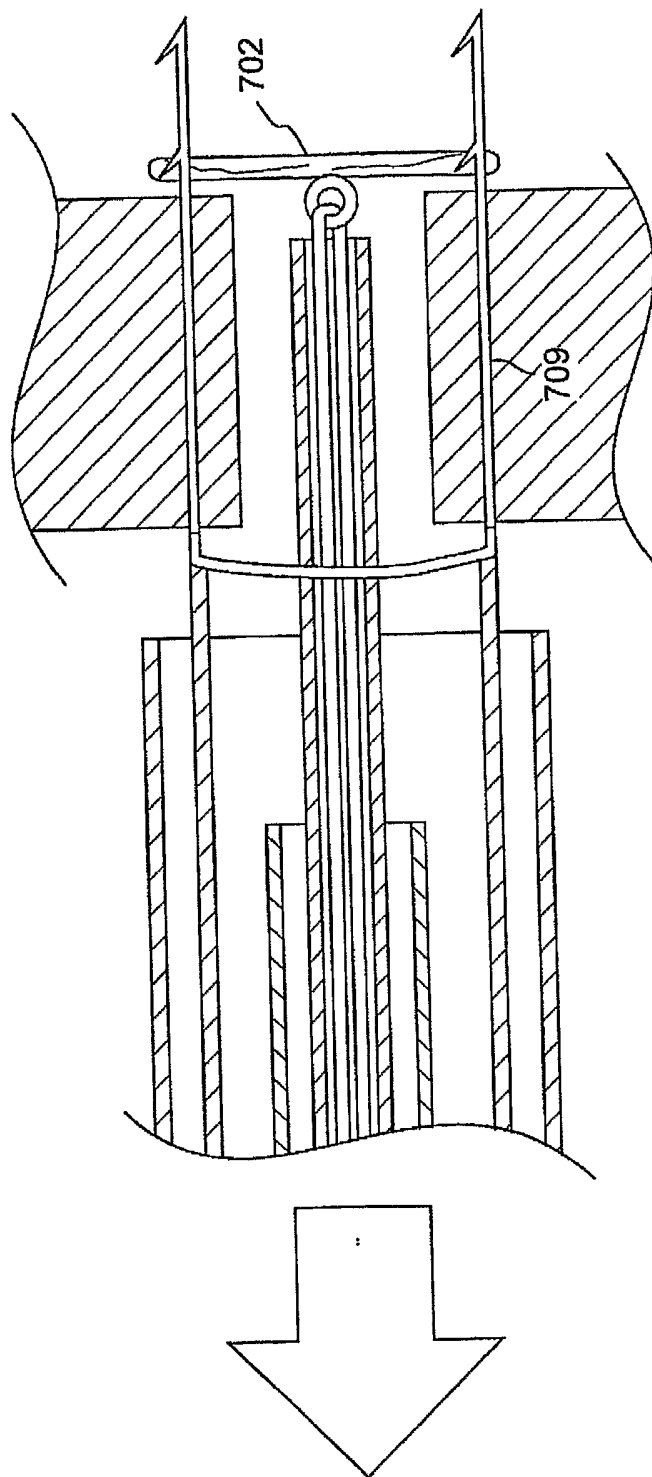

FIG. 16B

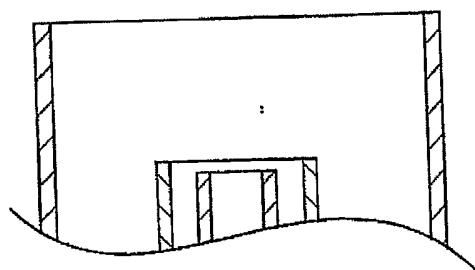
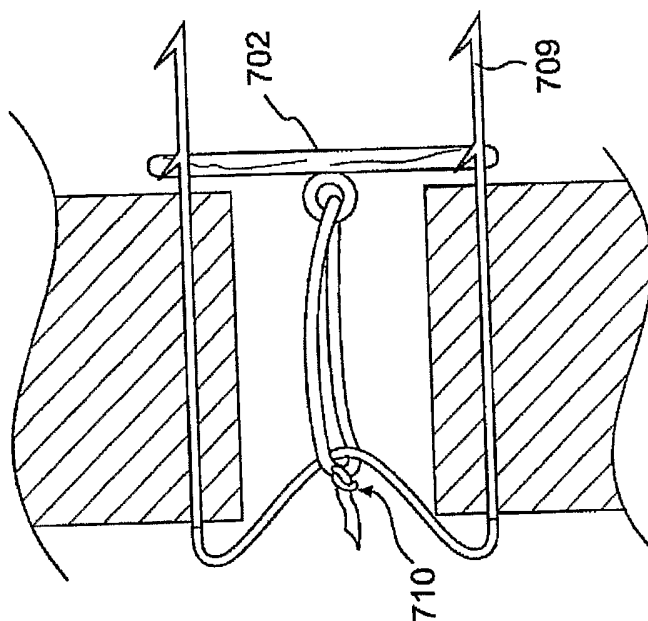

FIG. 16C

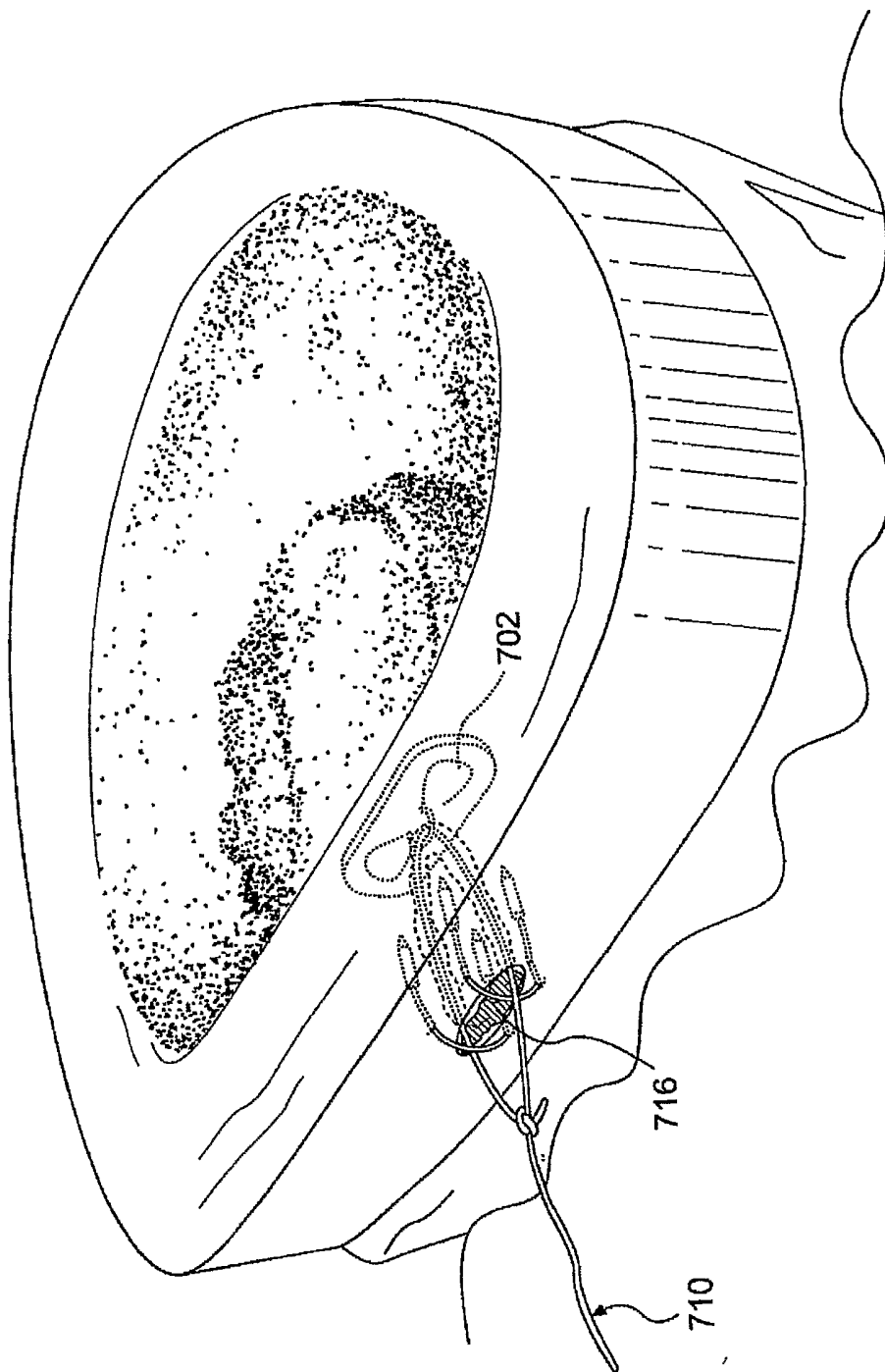

FIG. 17

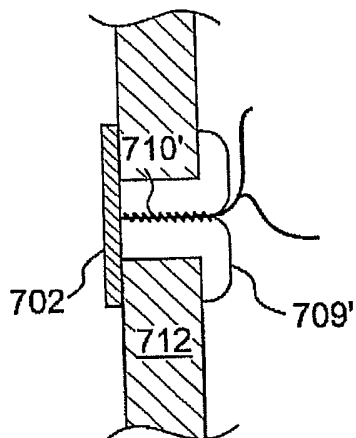

FIG. 18A

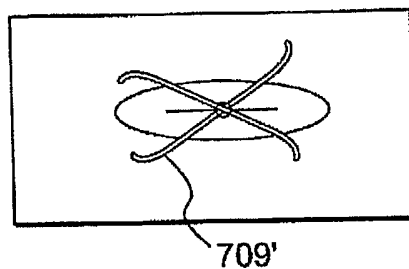

FIG. 18B

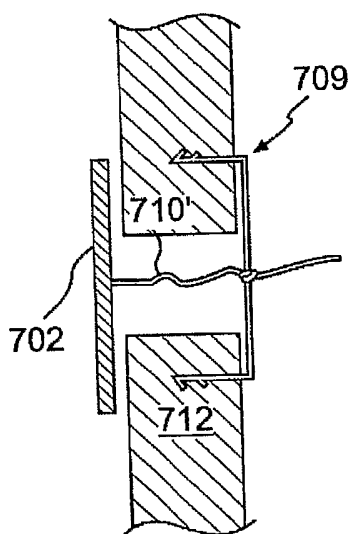

FIG. 18C

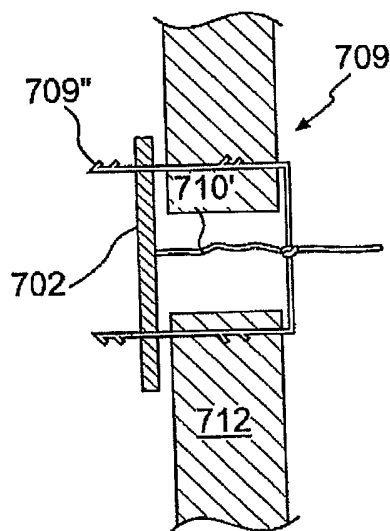

FIG. 18D

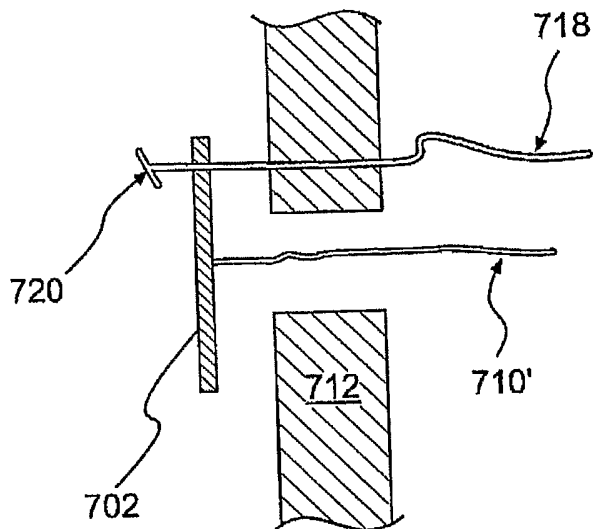

FIG. 18E

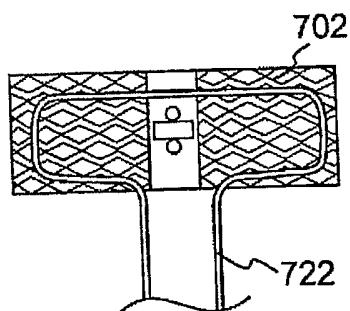

FIG. 19

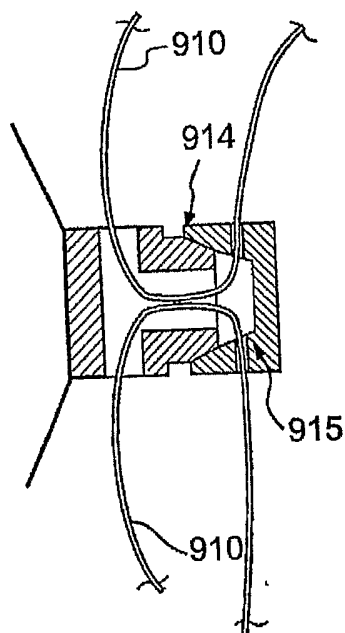

FIG. 20A

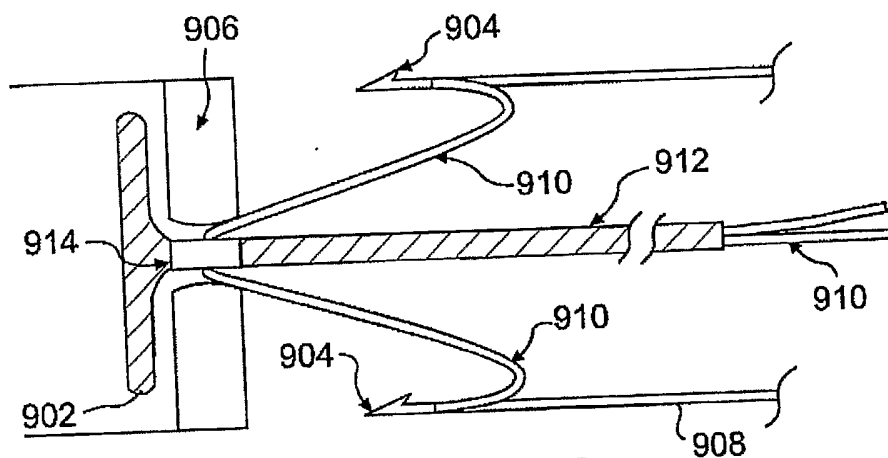

FIG. 20B

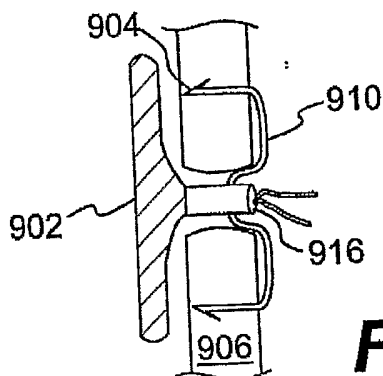

FIG. 20C

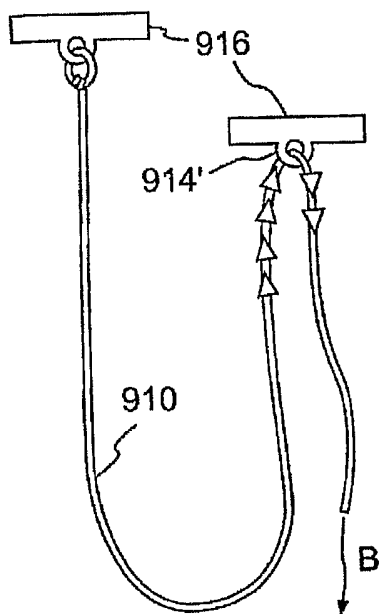

FIG. 21A

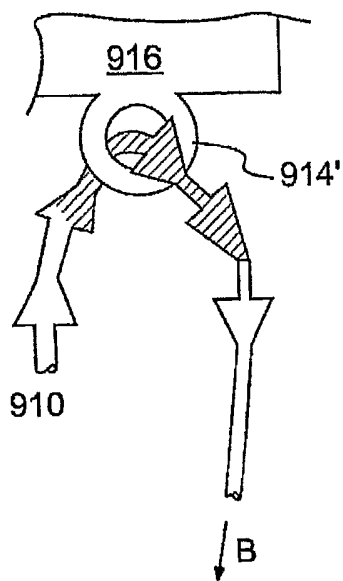

FIG. 21B

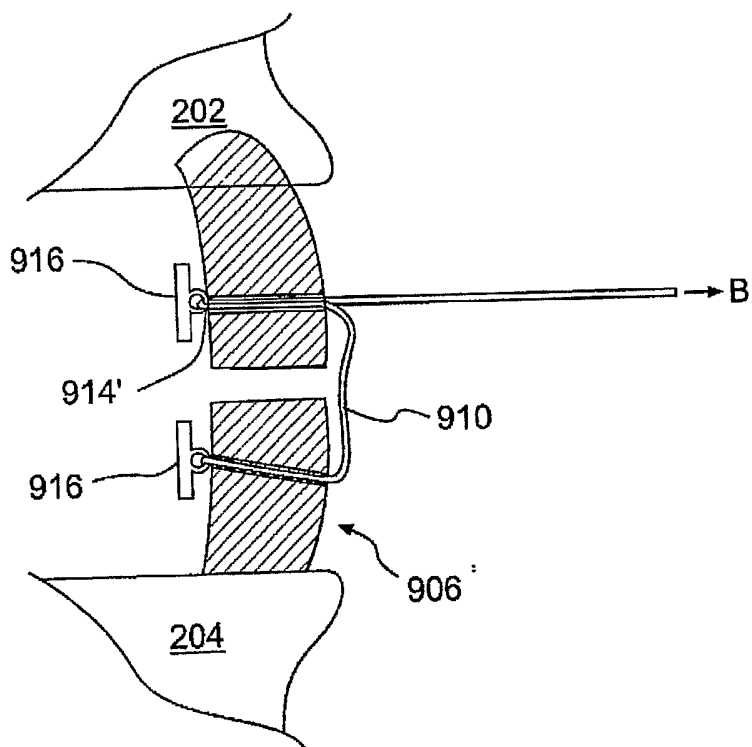

FIG. 21C

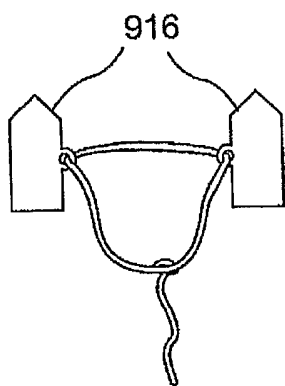

FIG. 22A

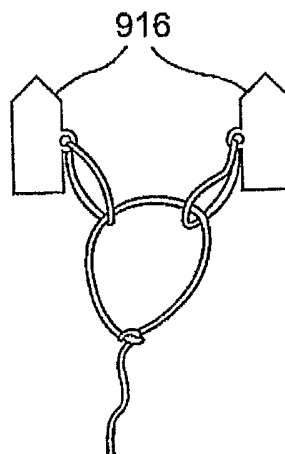

FIG. 22B

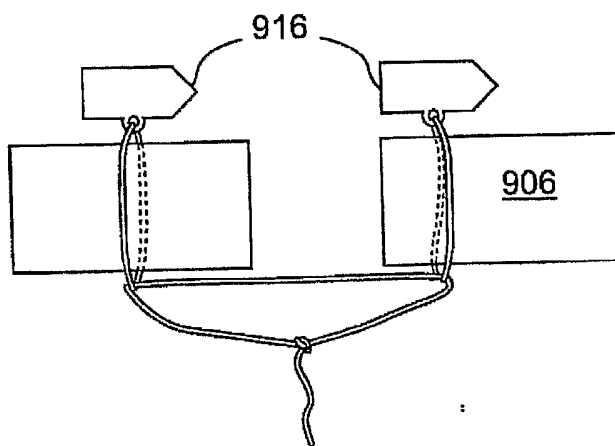

FIG. 22C

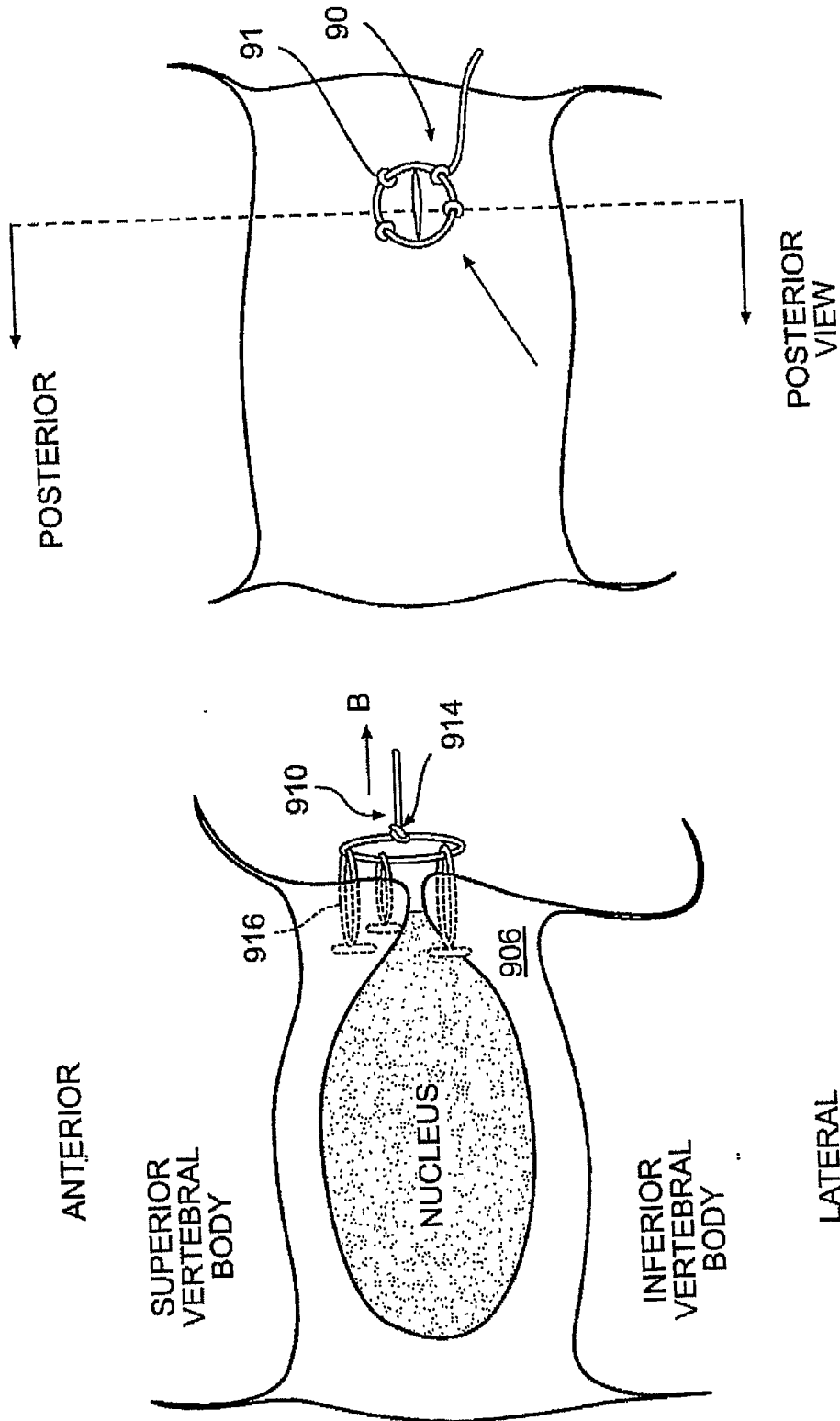

FIG. 23

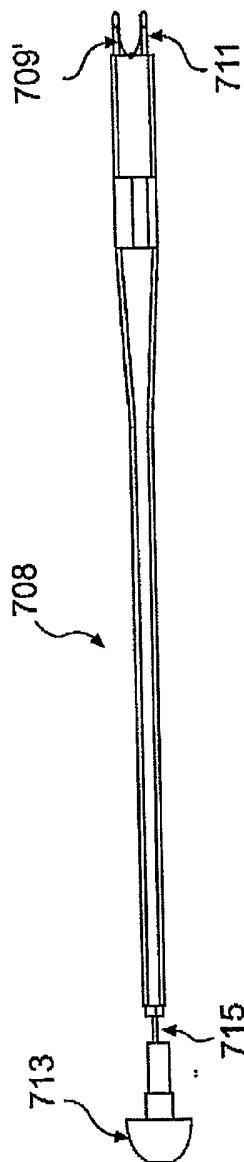

FIG. 24A

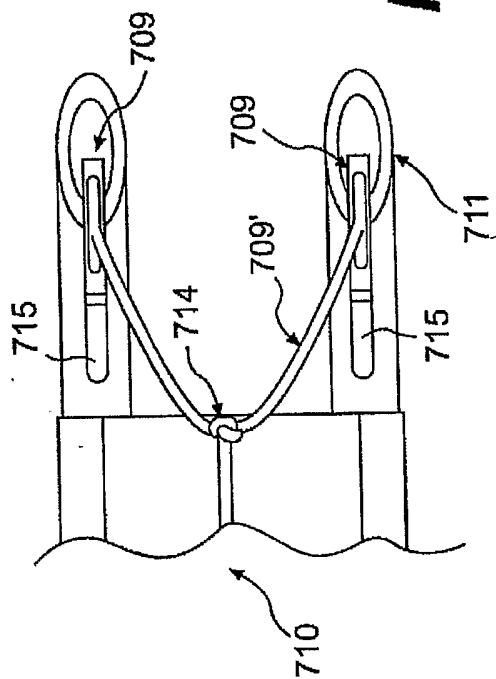

FIG. 24B

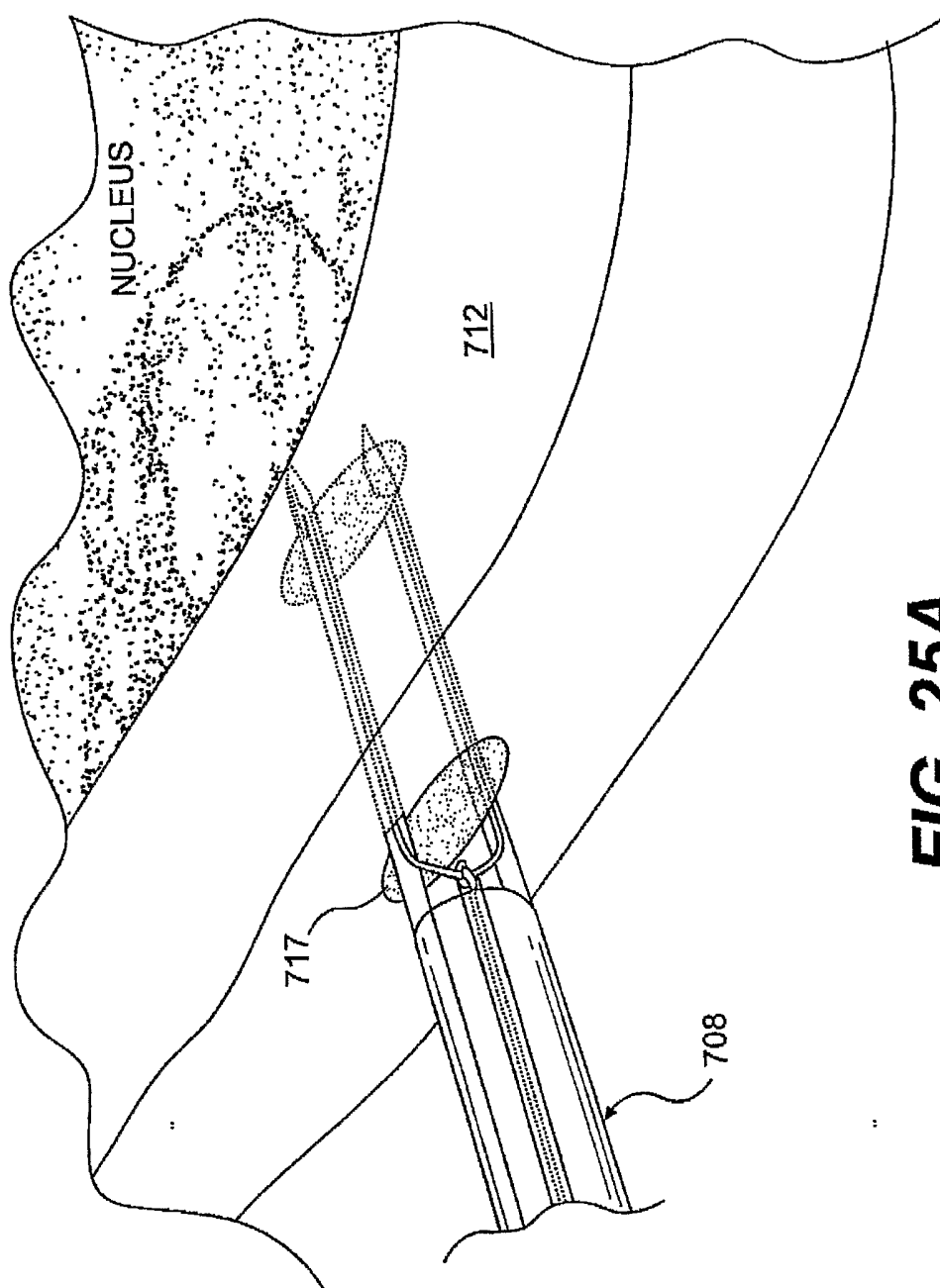

FIG. 25A

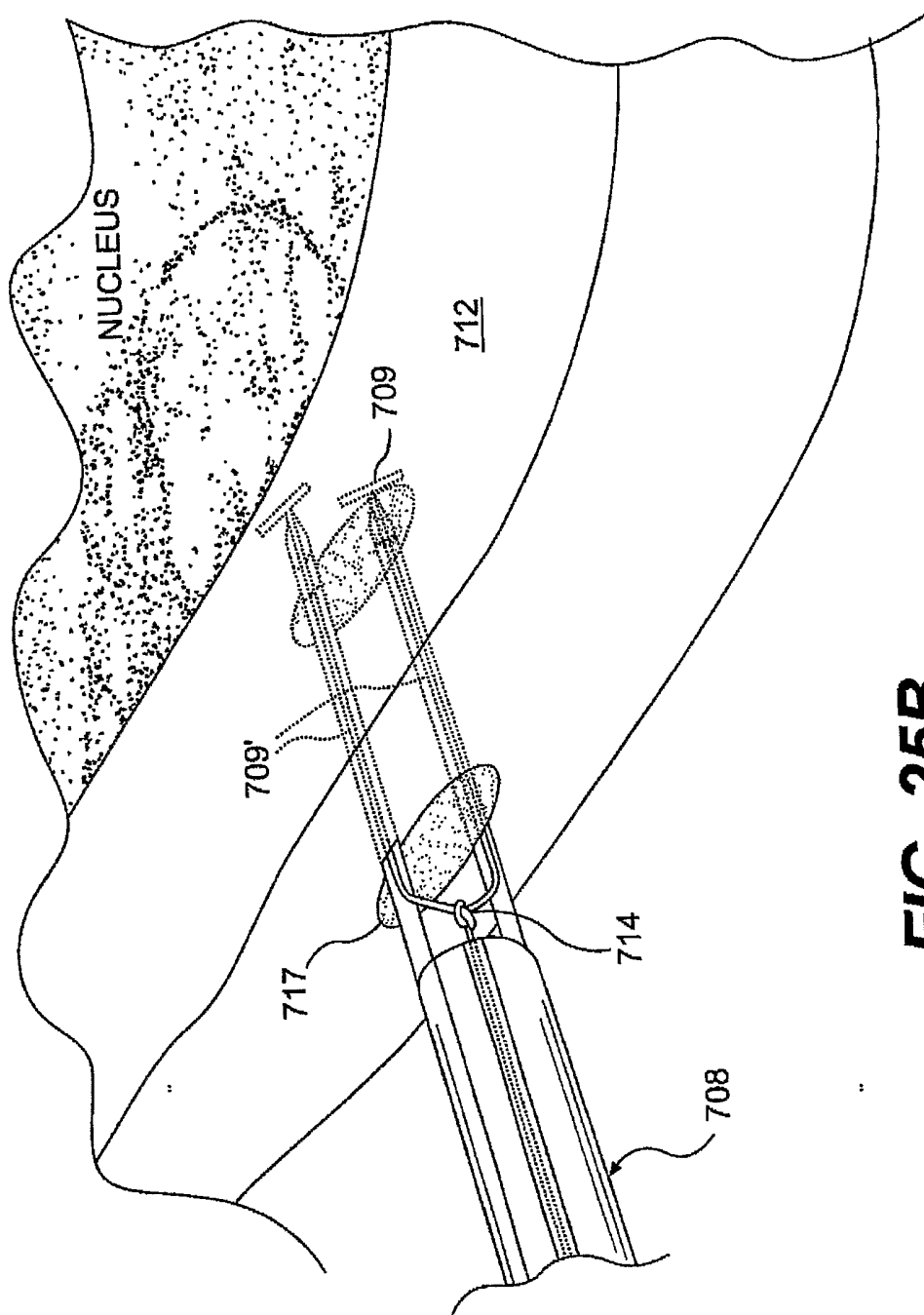

FIG. 25B

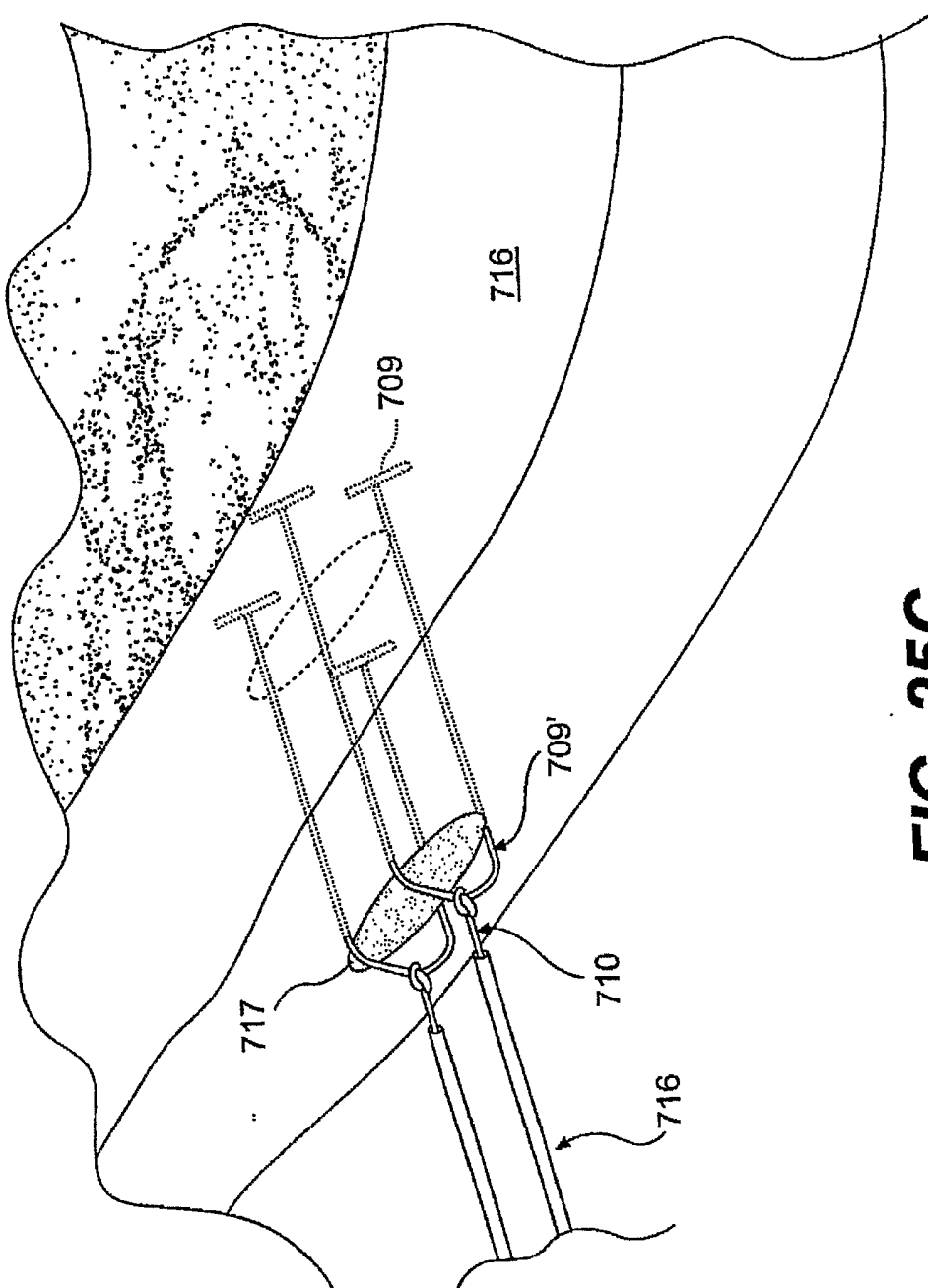

FIG. 25C

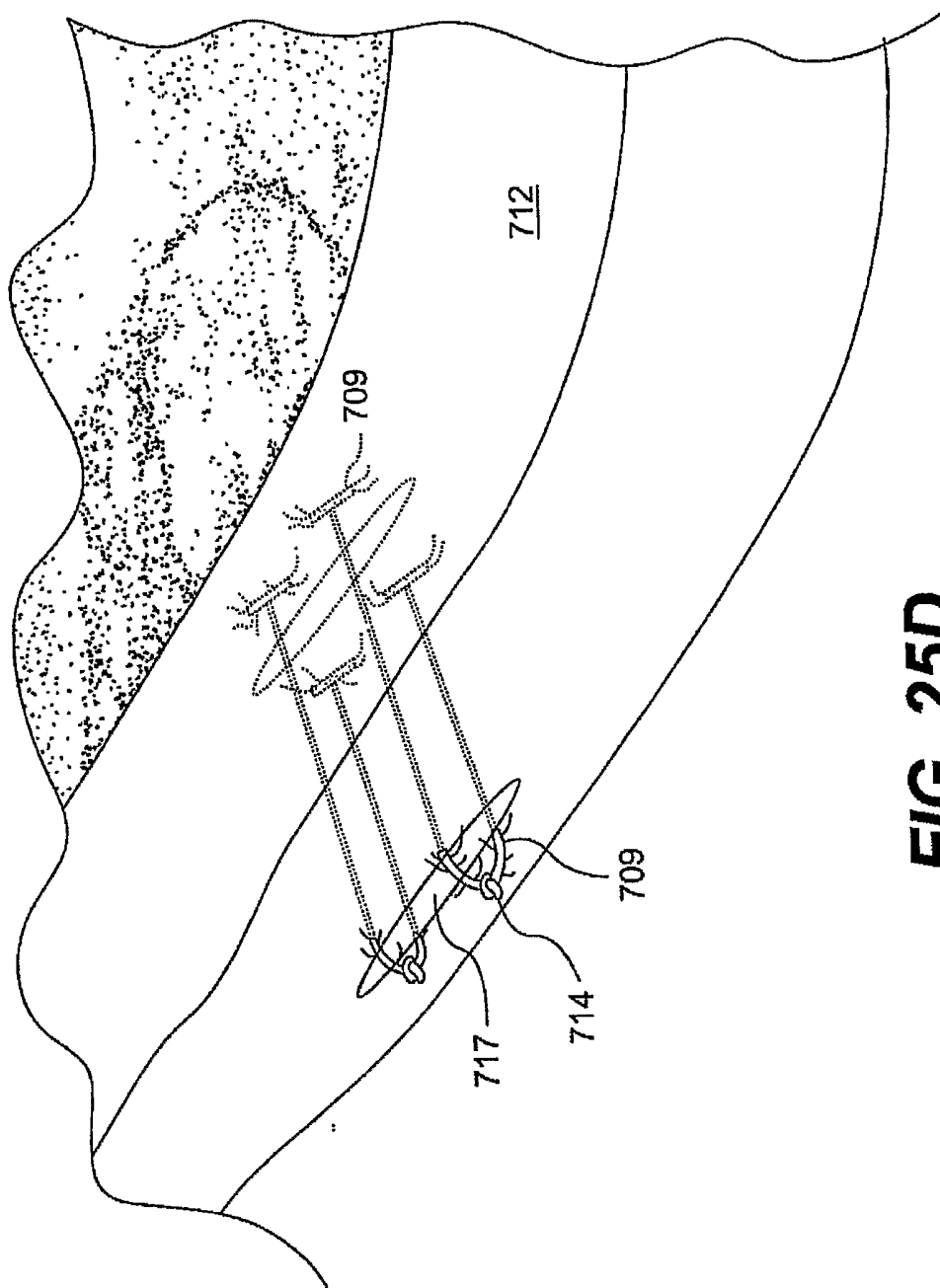

FIG. 25D

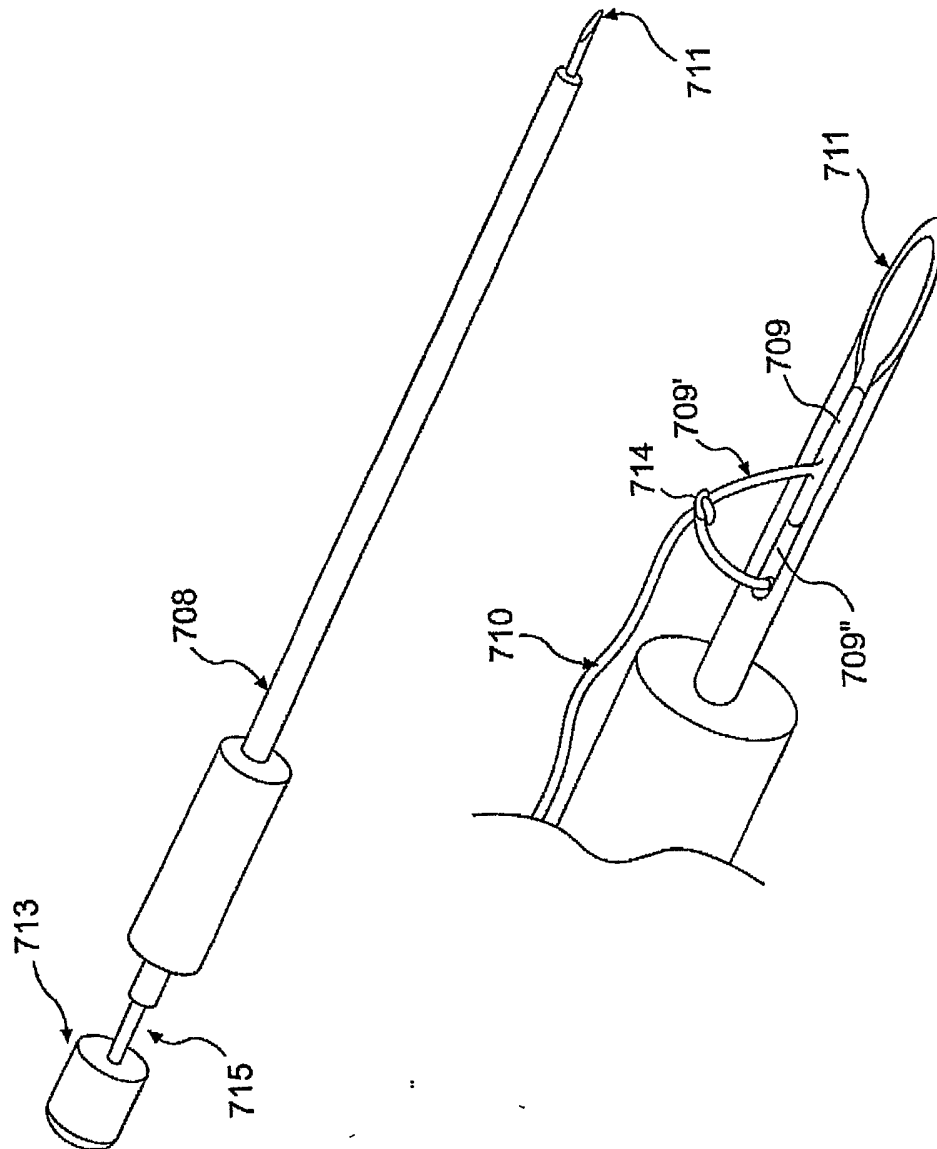

FIG. 26

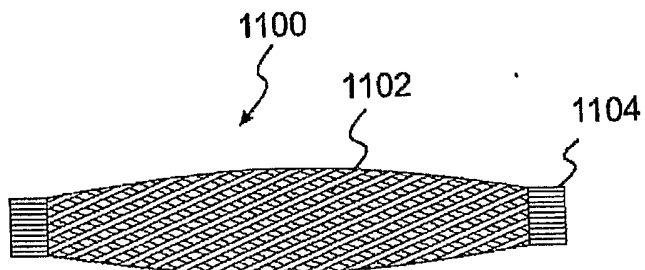

FIG. 27A

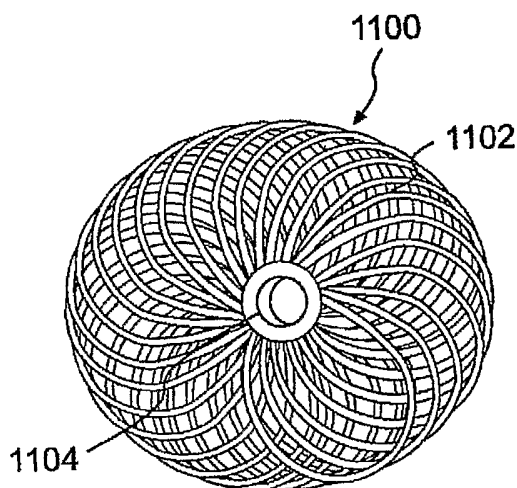

FIG. 27B

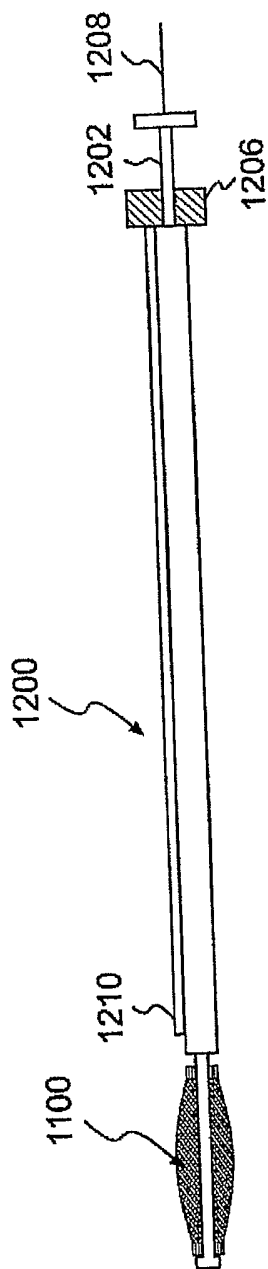

FIG. 28

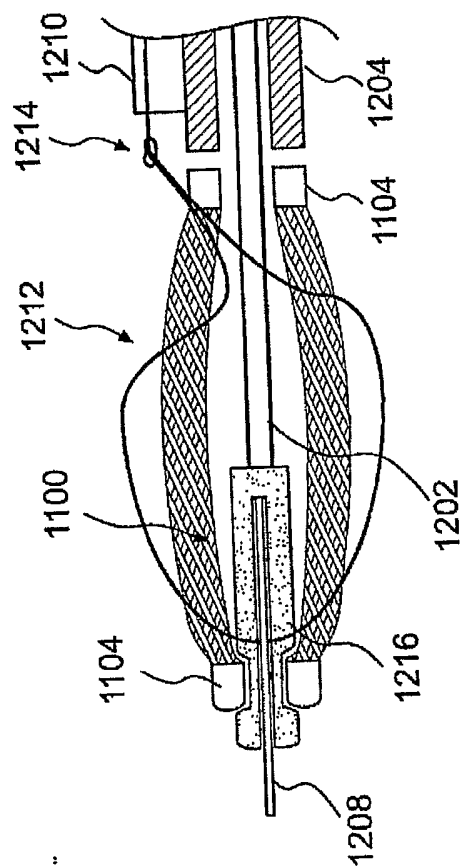

FIG. 29

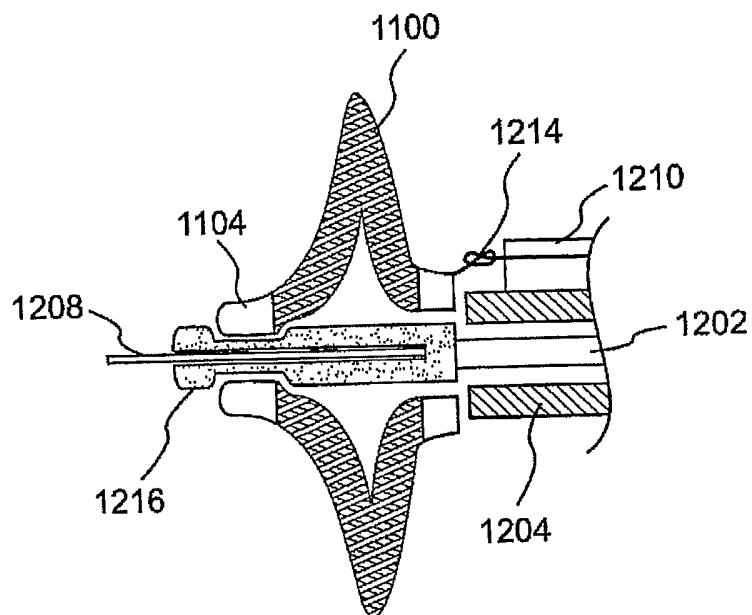

FIG. 30

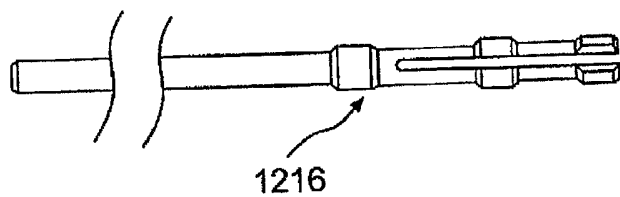

FIG. 31

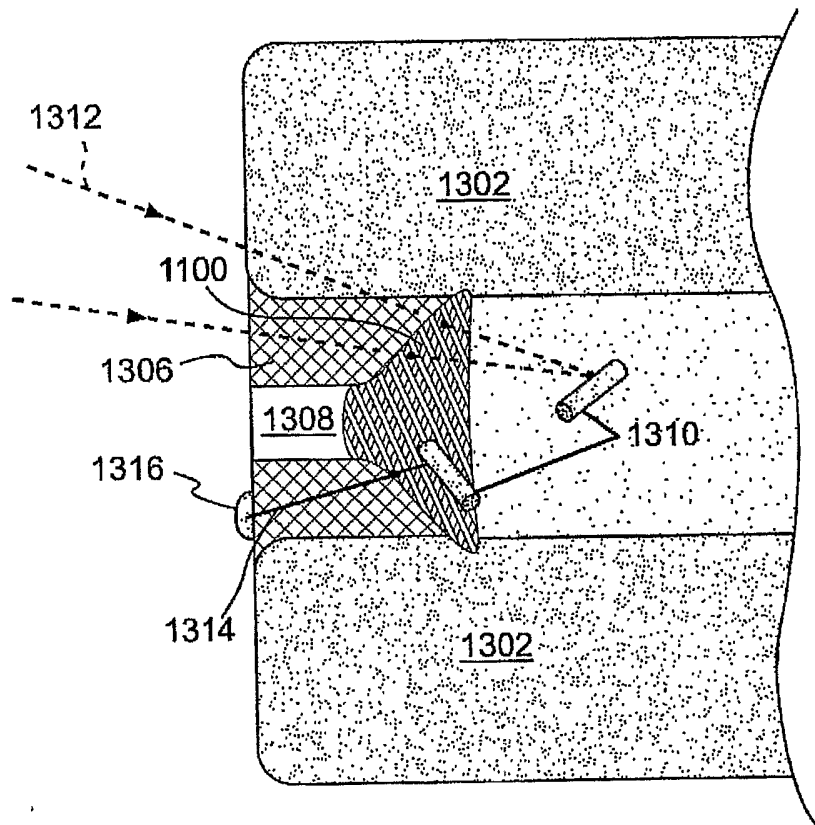

FIG. 32

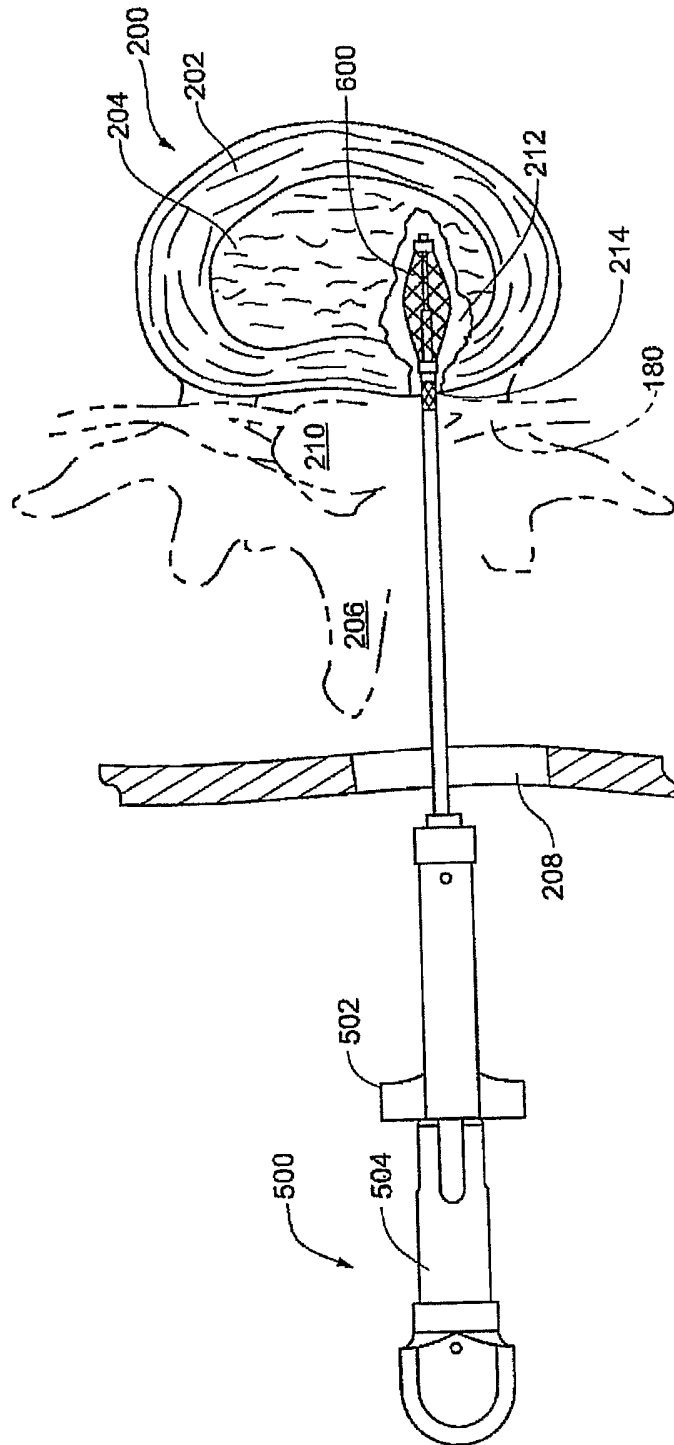
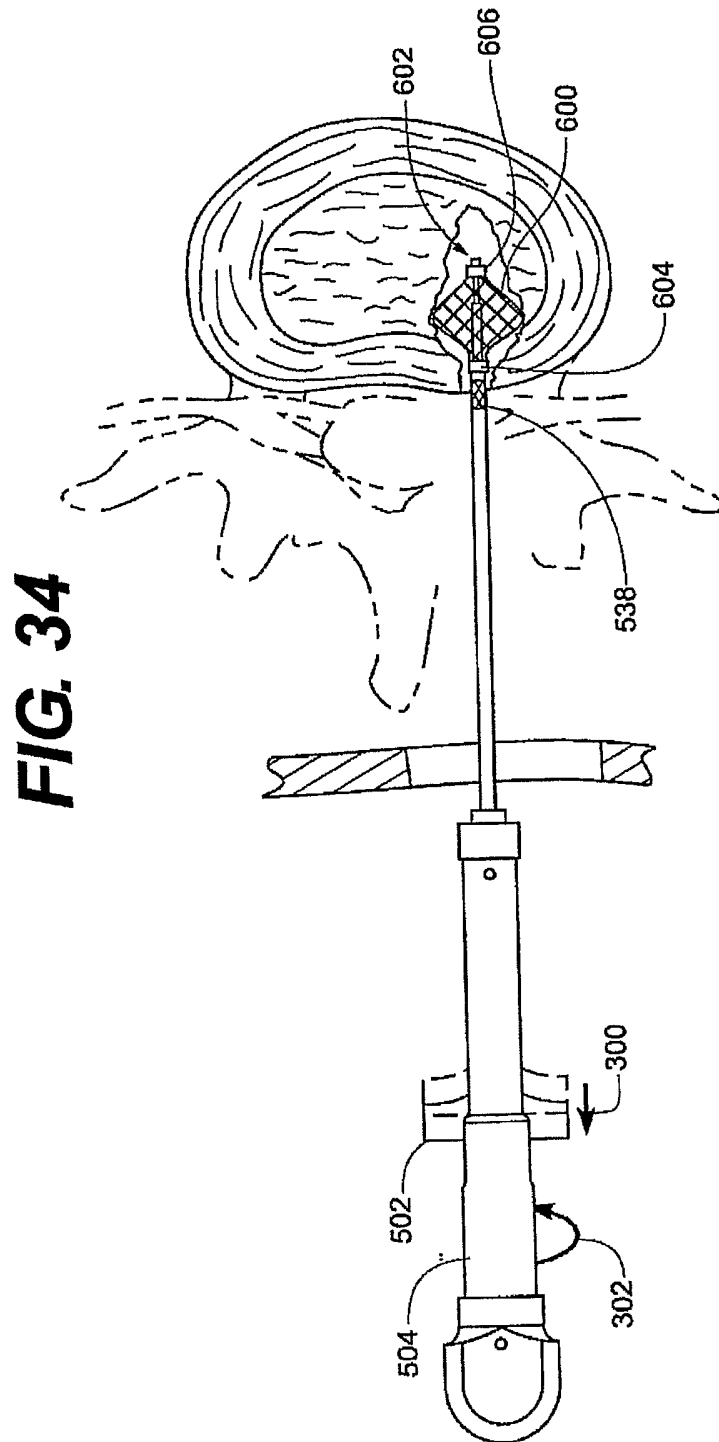
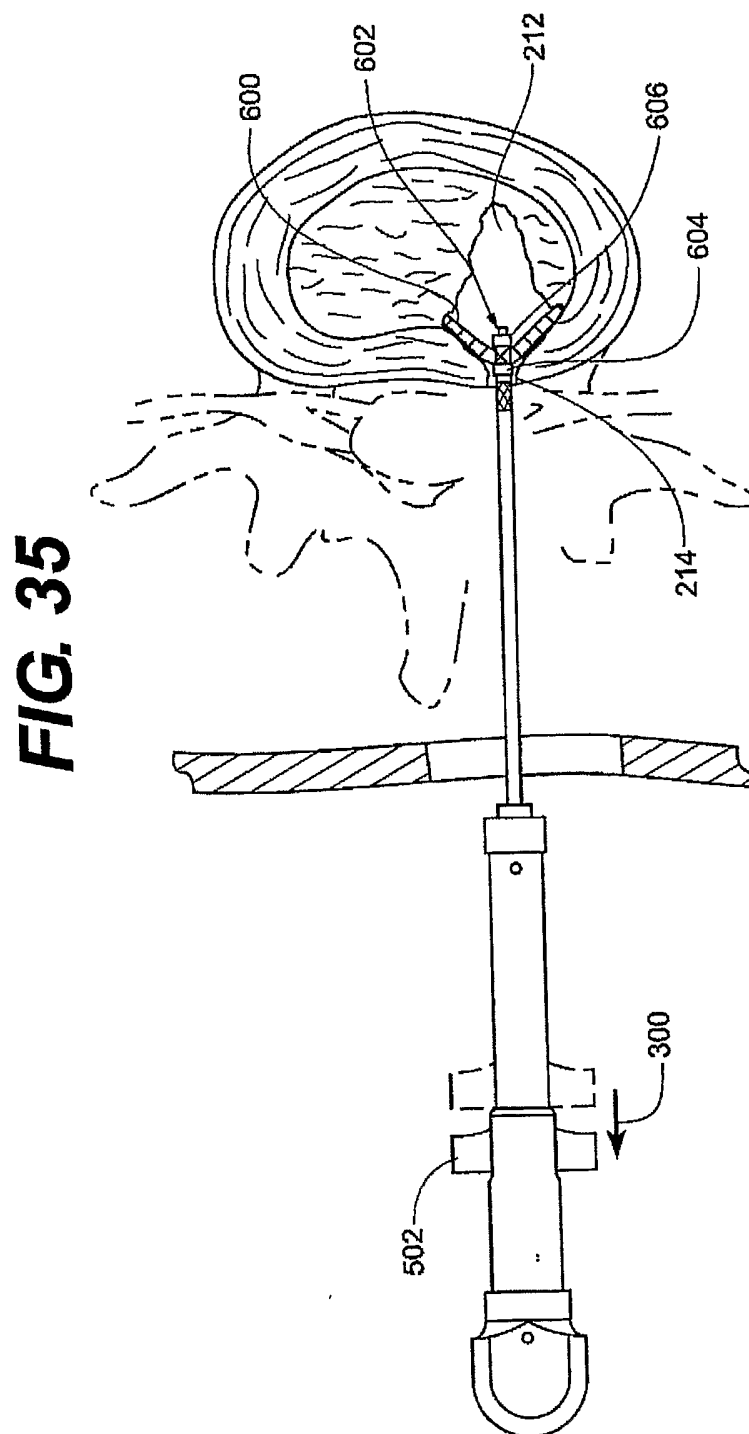

FIG. 33





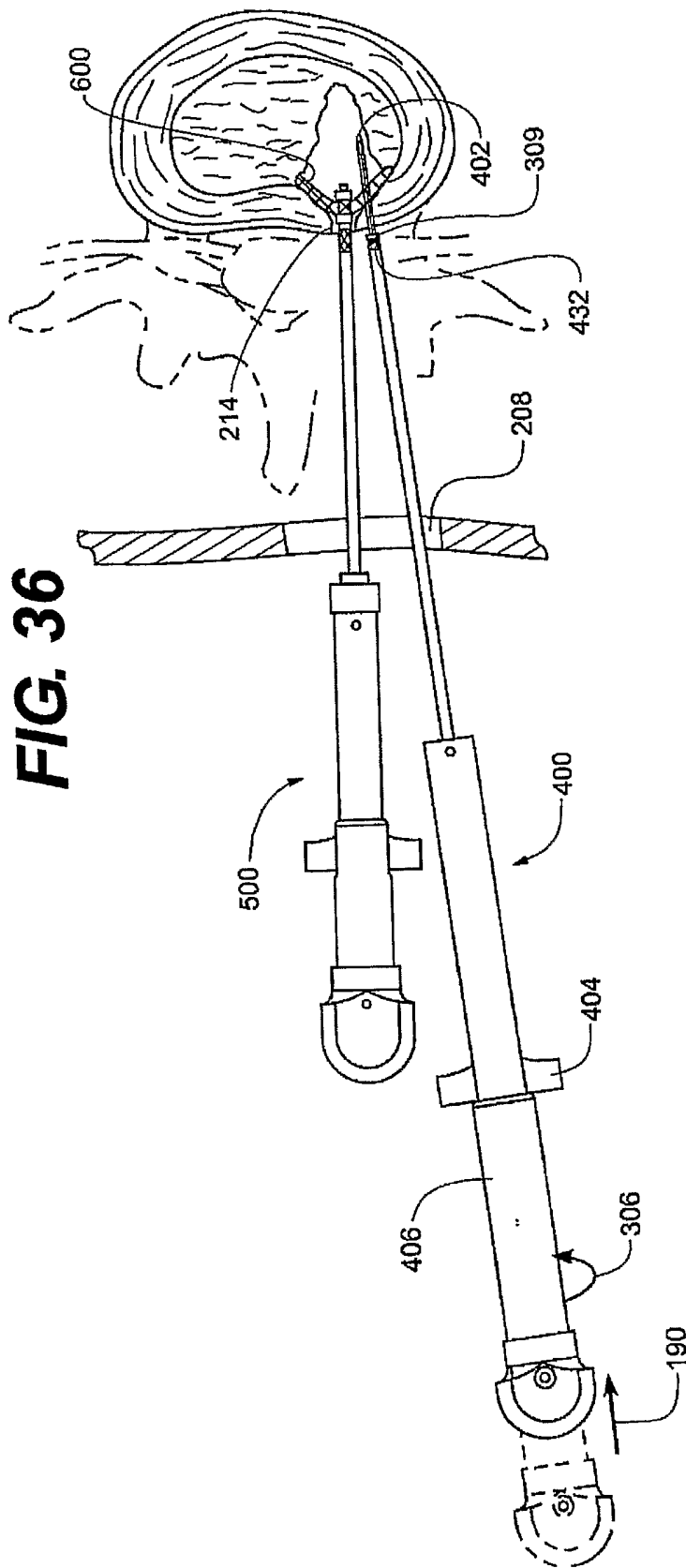

FIG. 36

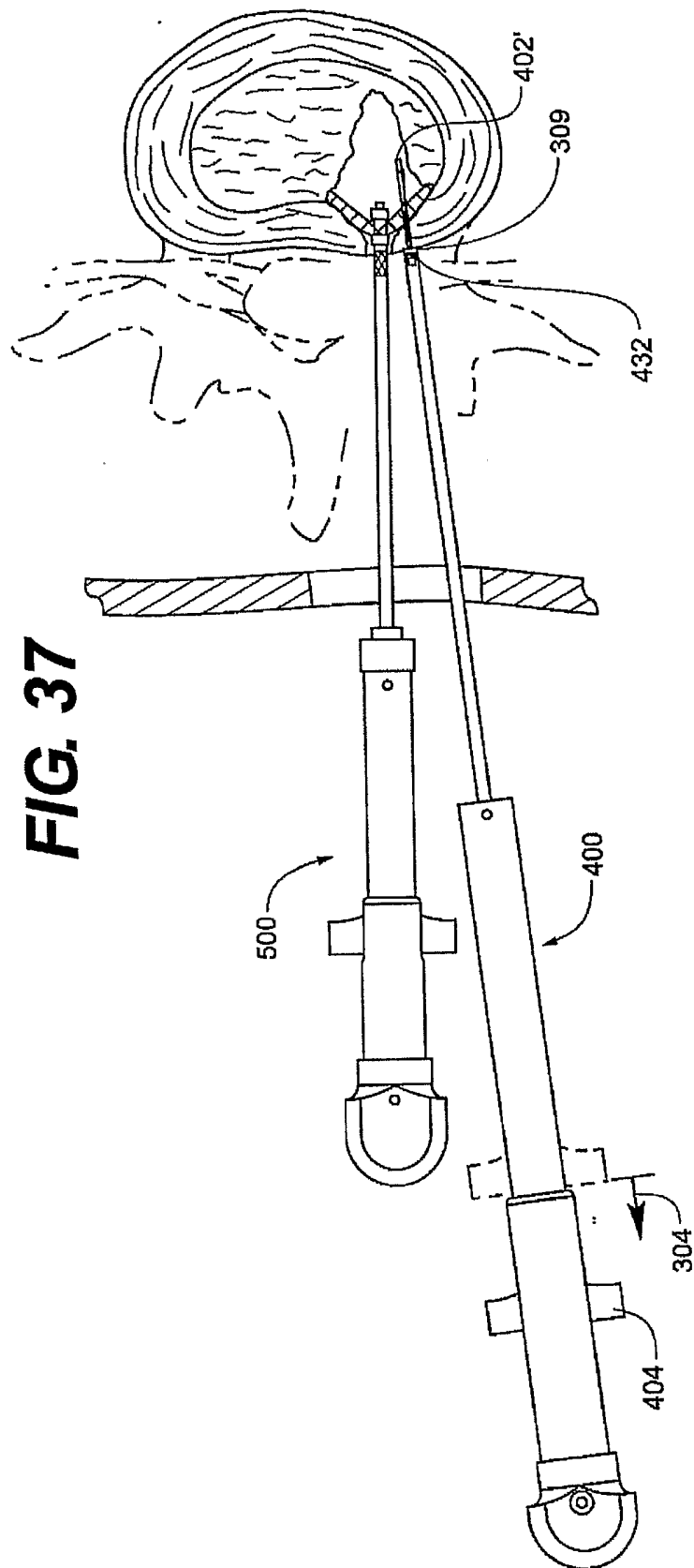
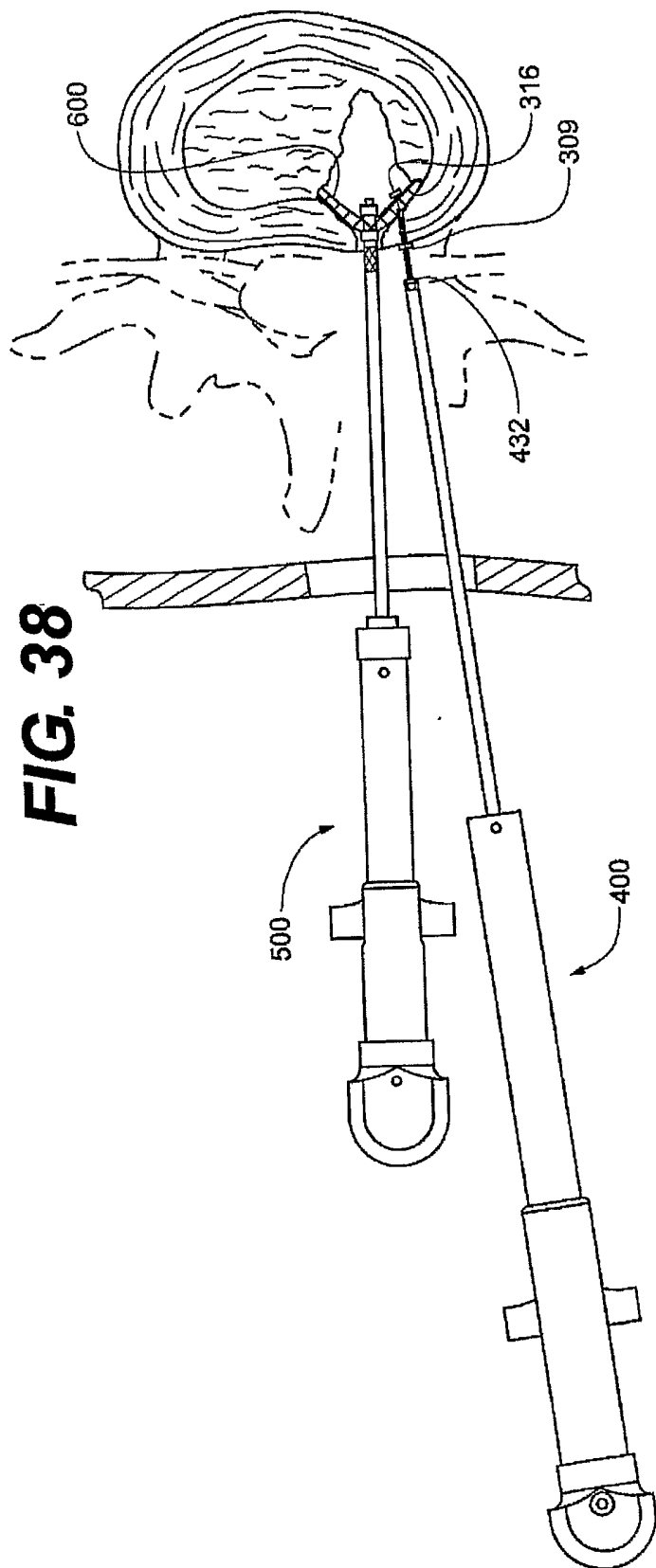
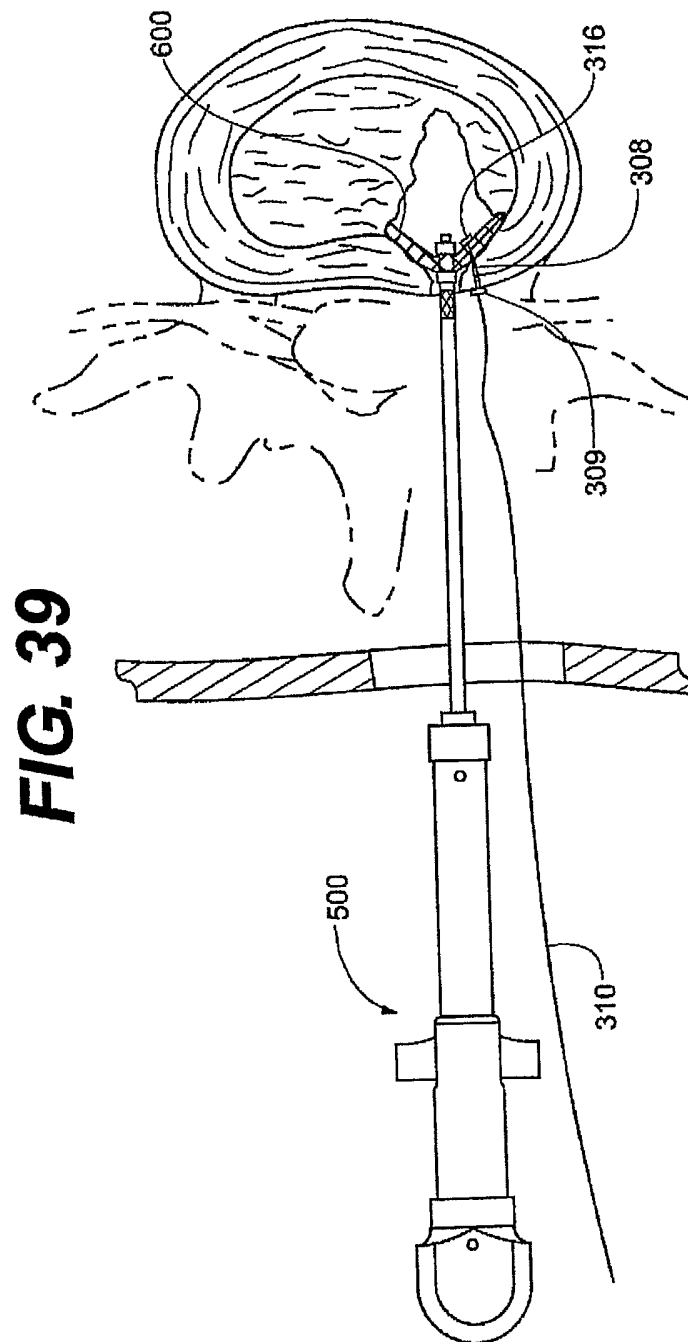

FIG. 37





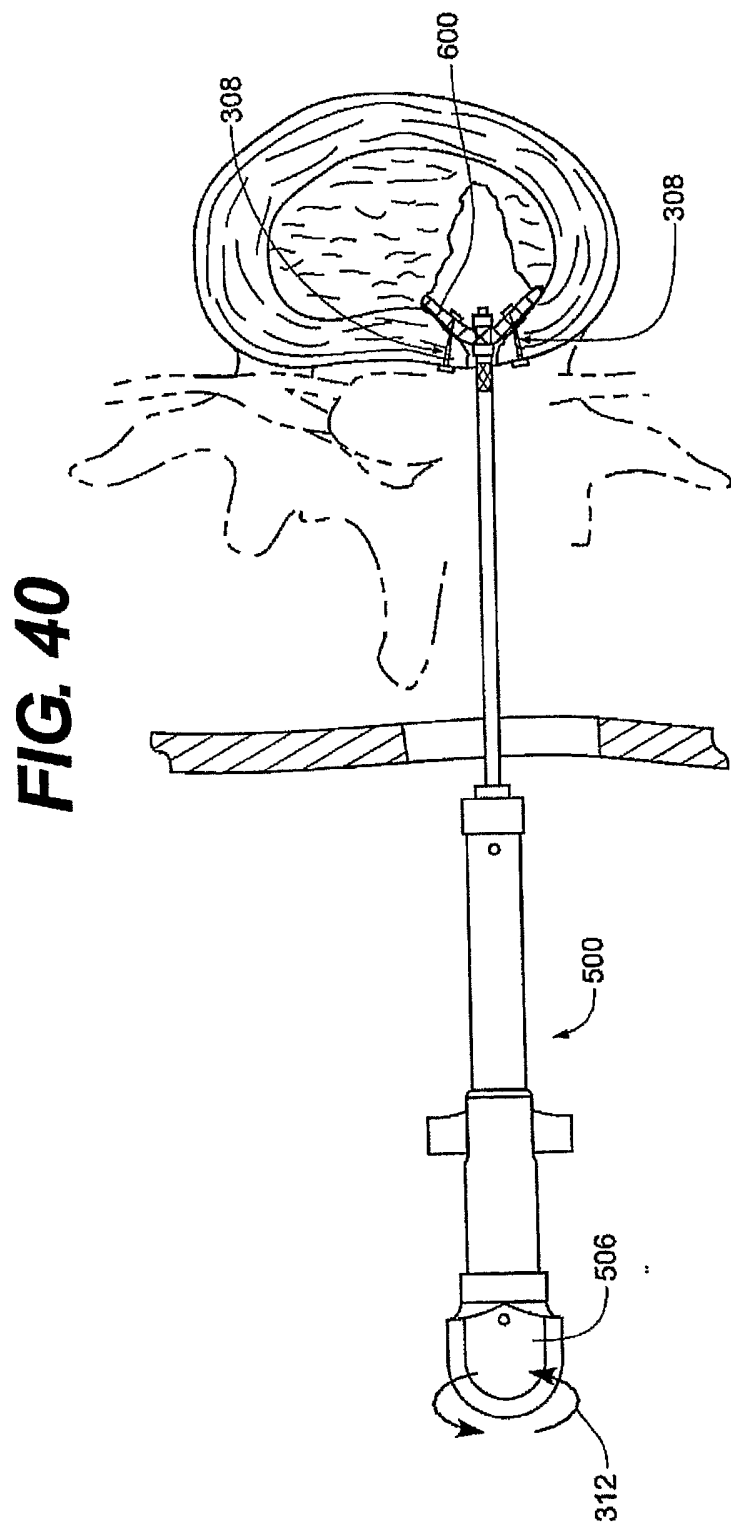

FIG. 40

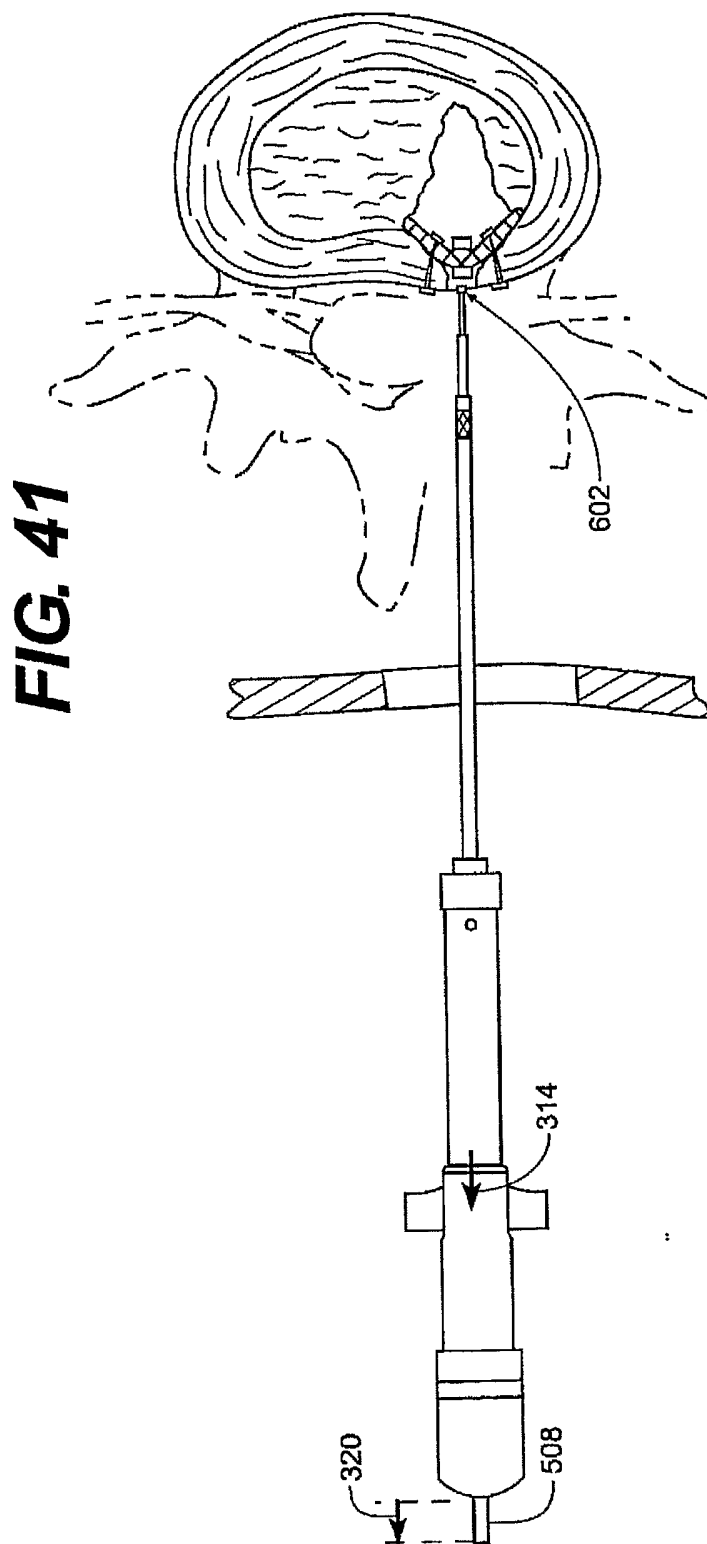

FIG. 42

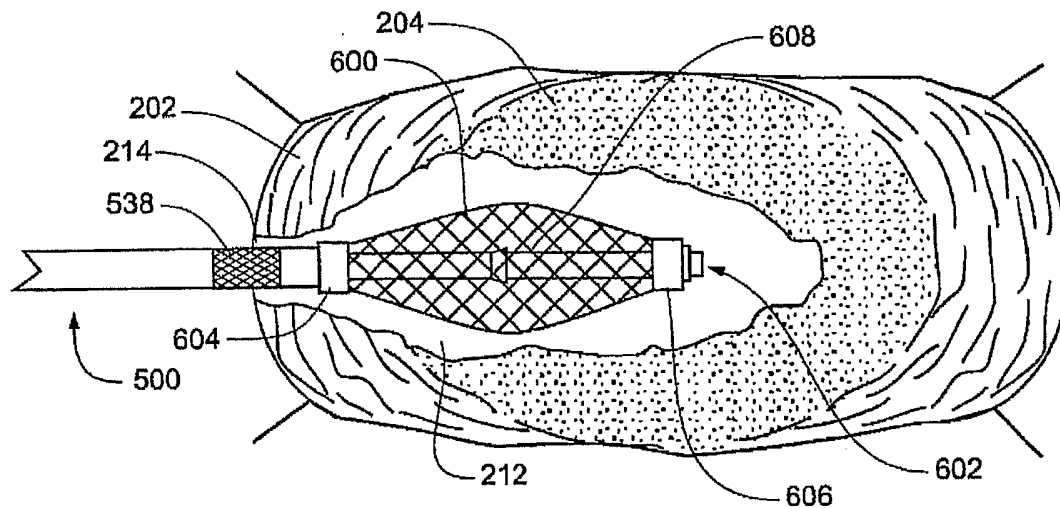

FIG. 43

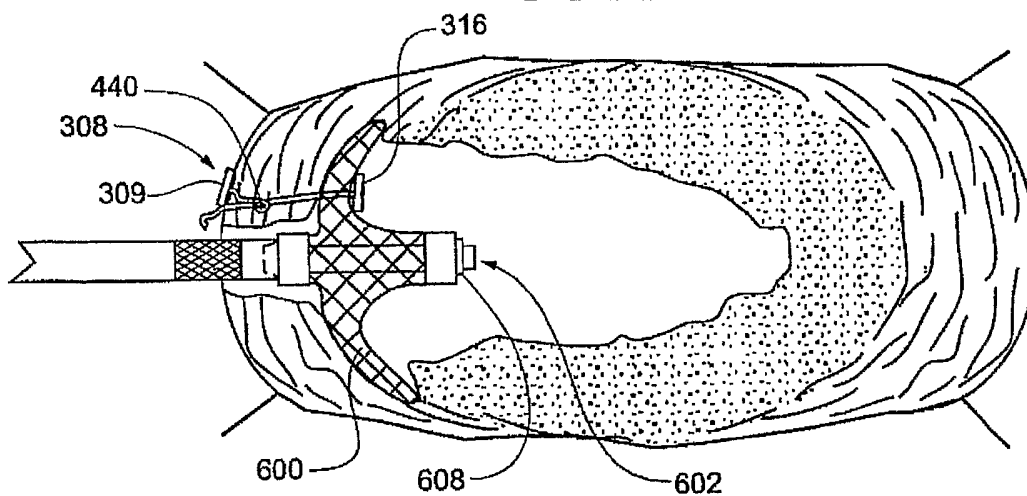

FIG. 44

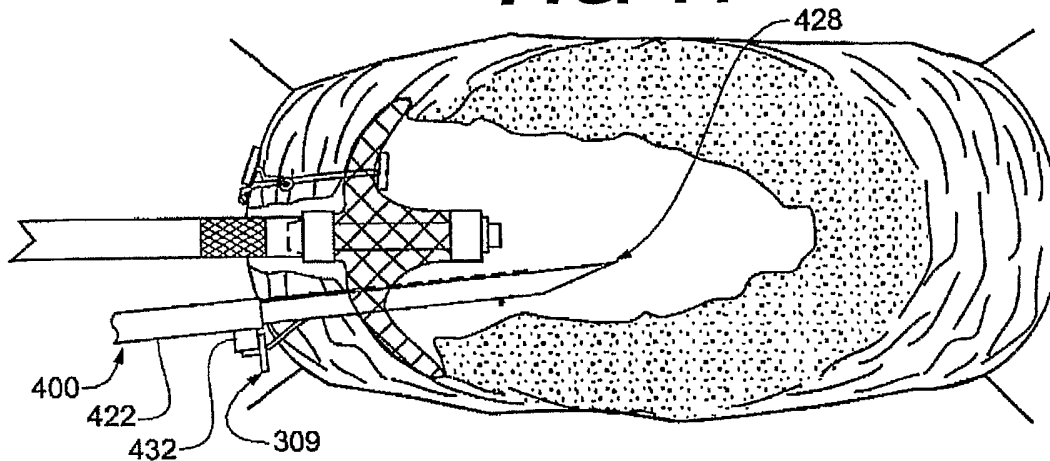

FIG. 45

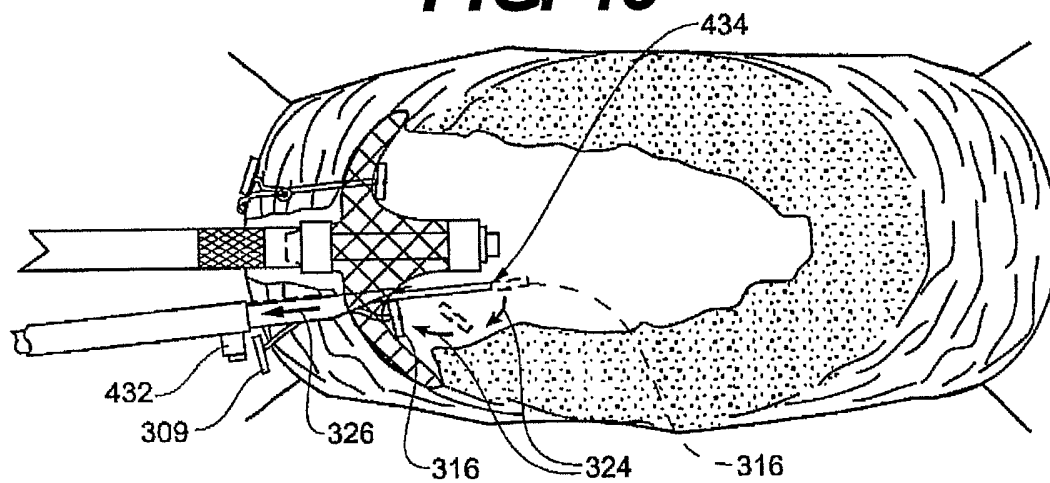

FIG. 46

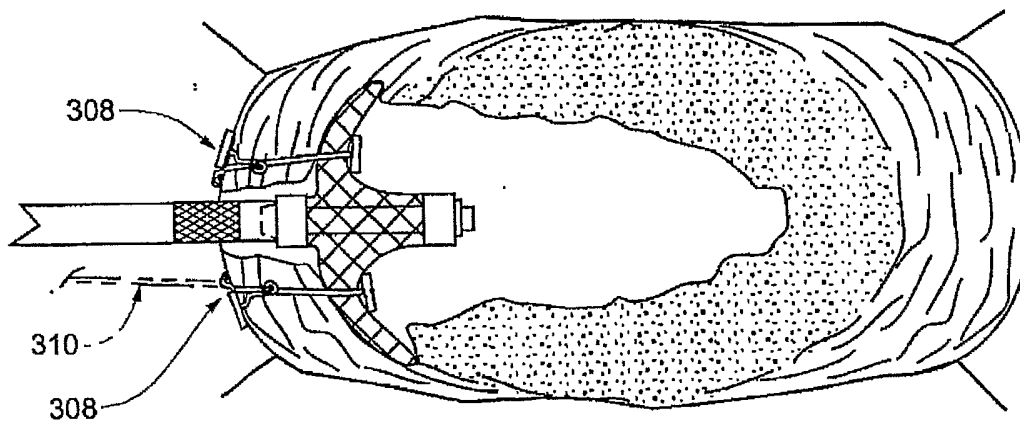

FIG. 47

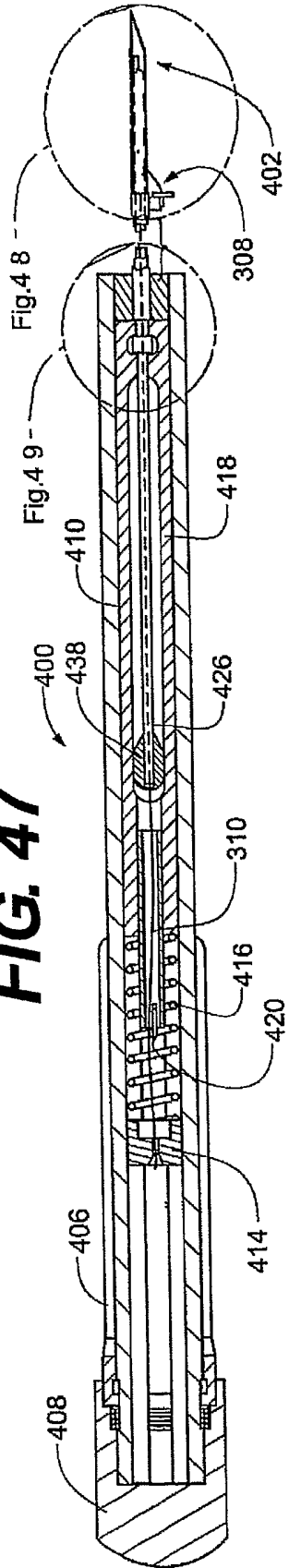

FIG. 48

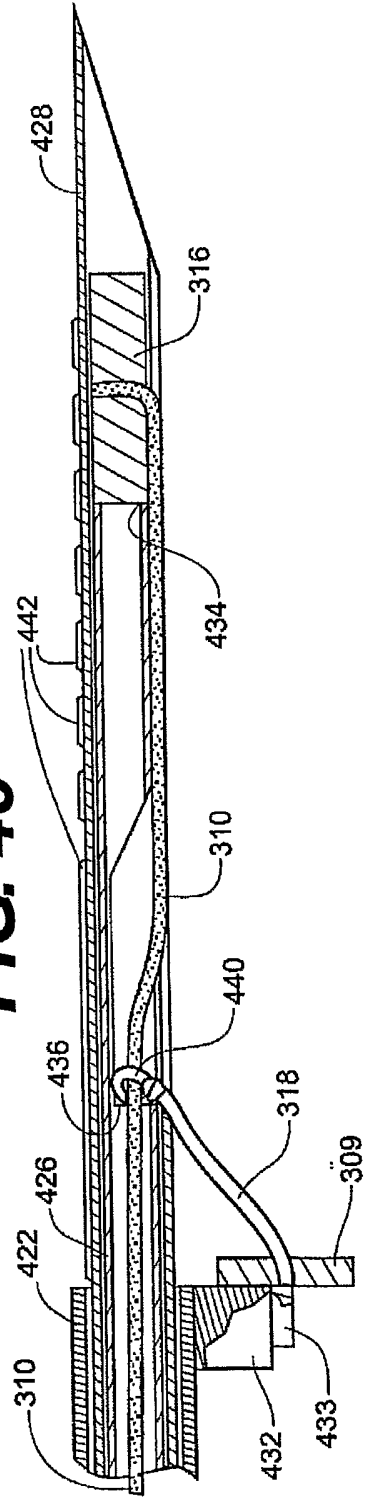
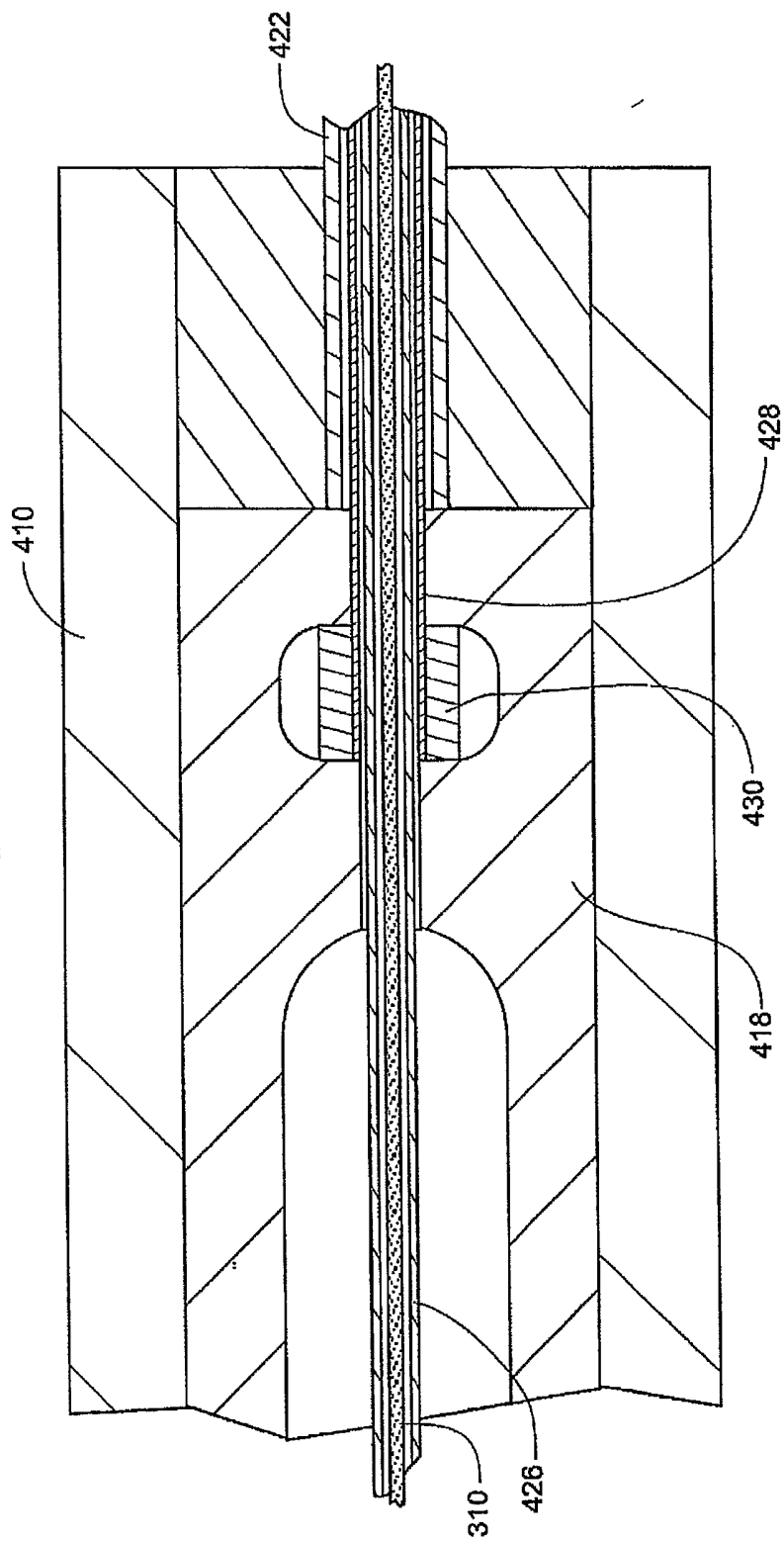

FIG. 49



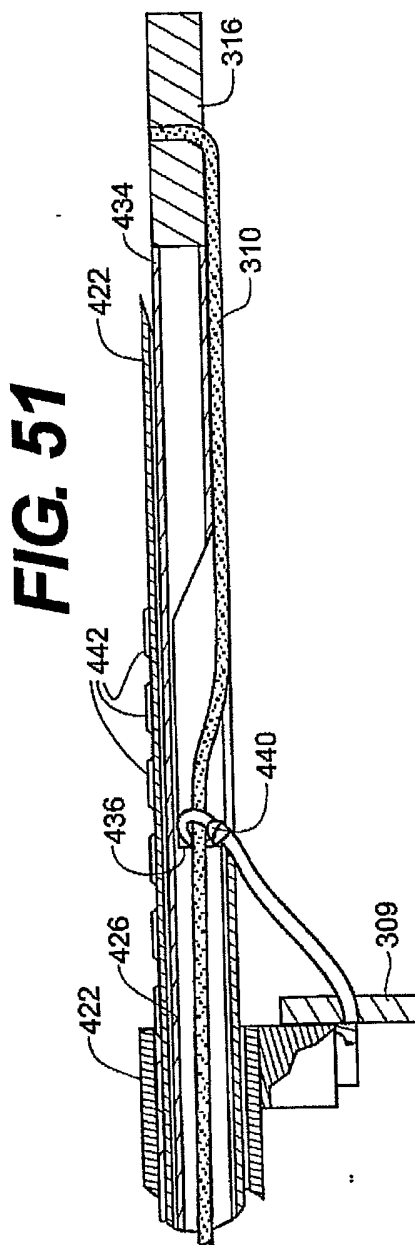
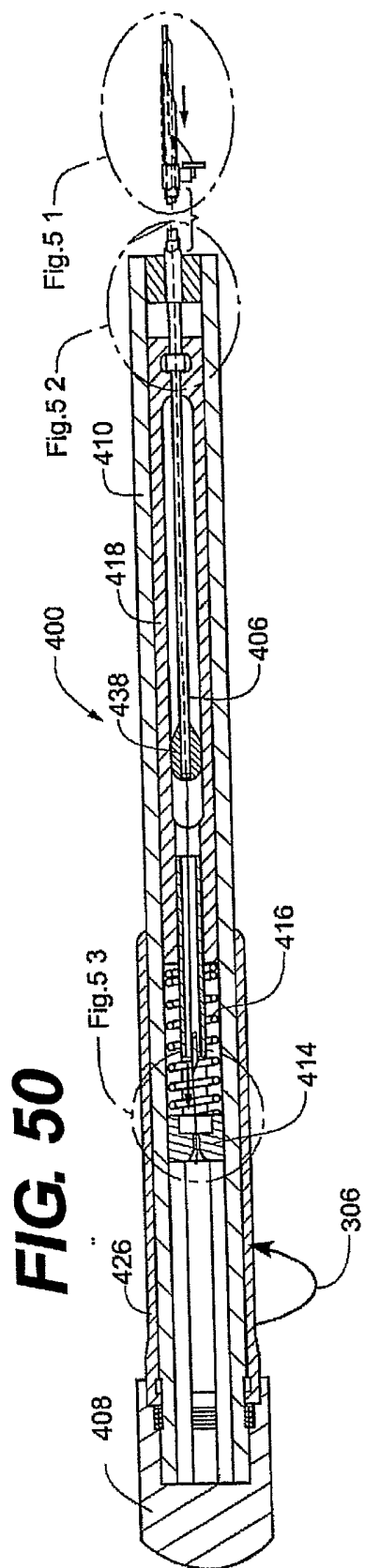

FIG. 52

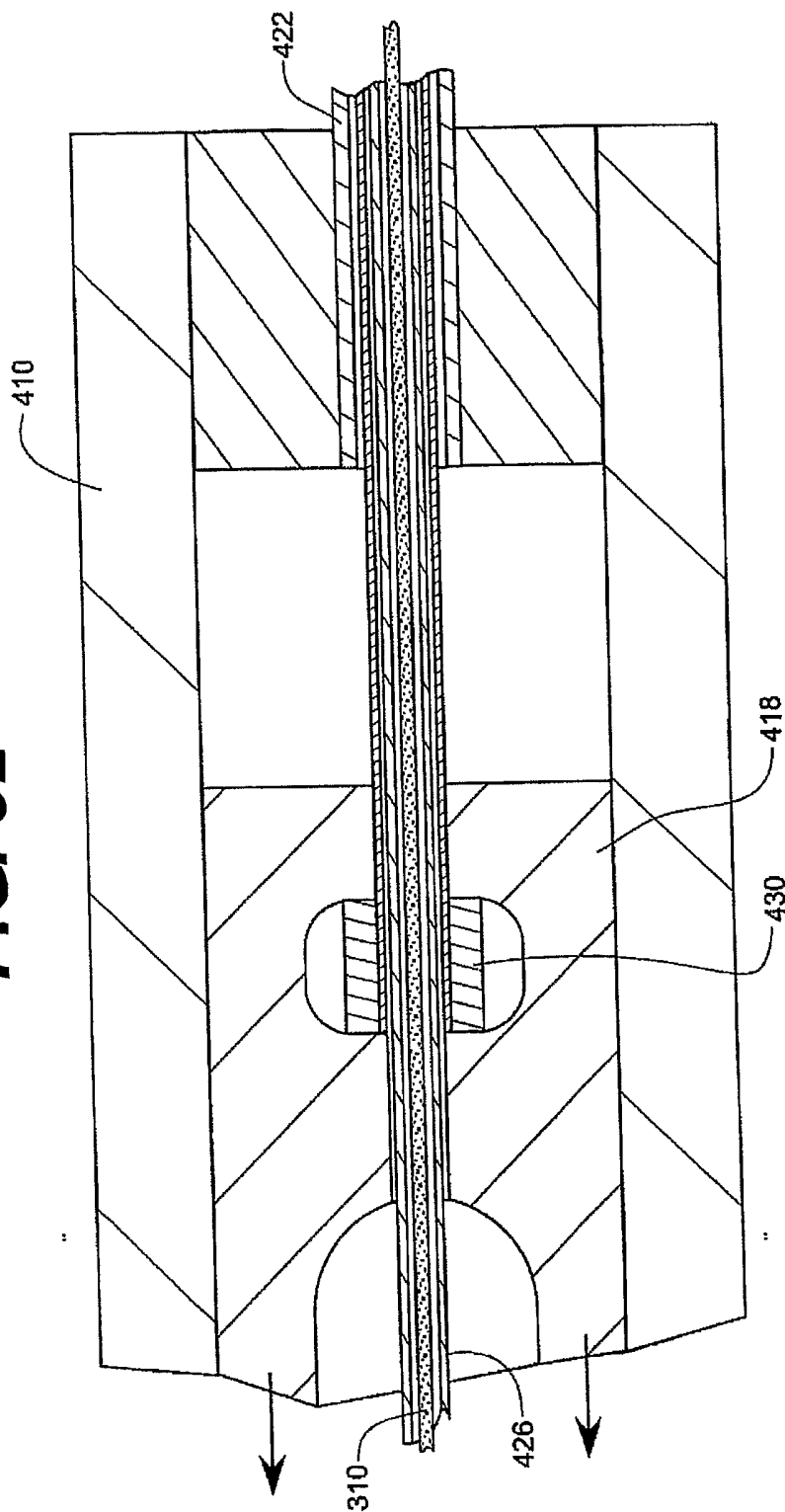
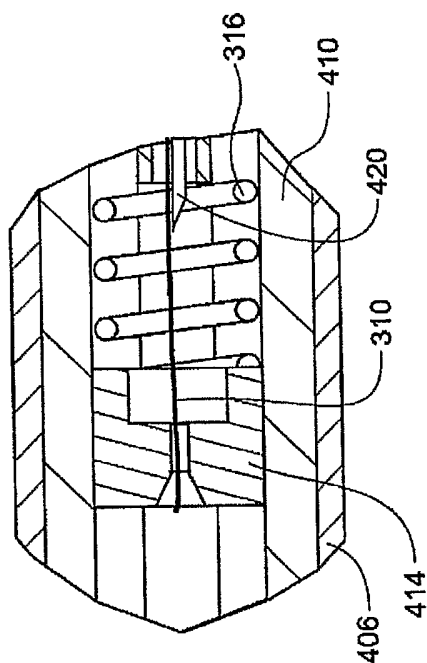

FIG. 53



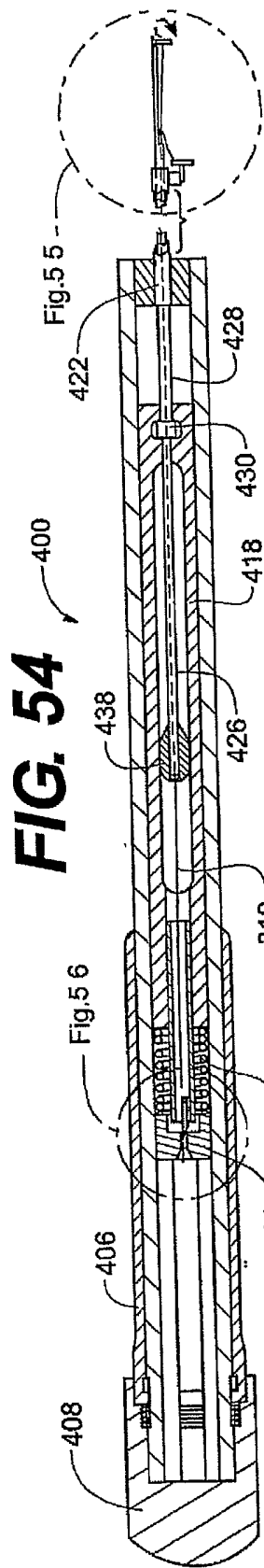

FIG. 54

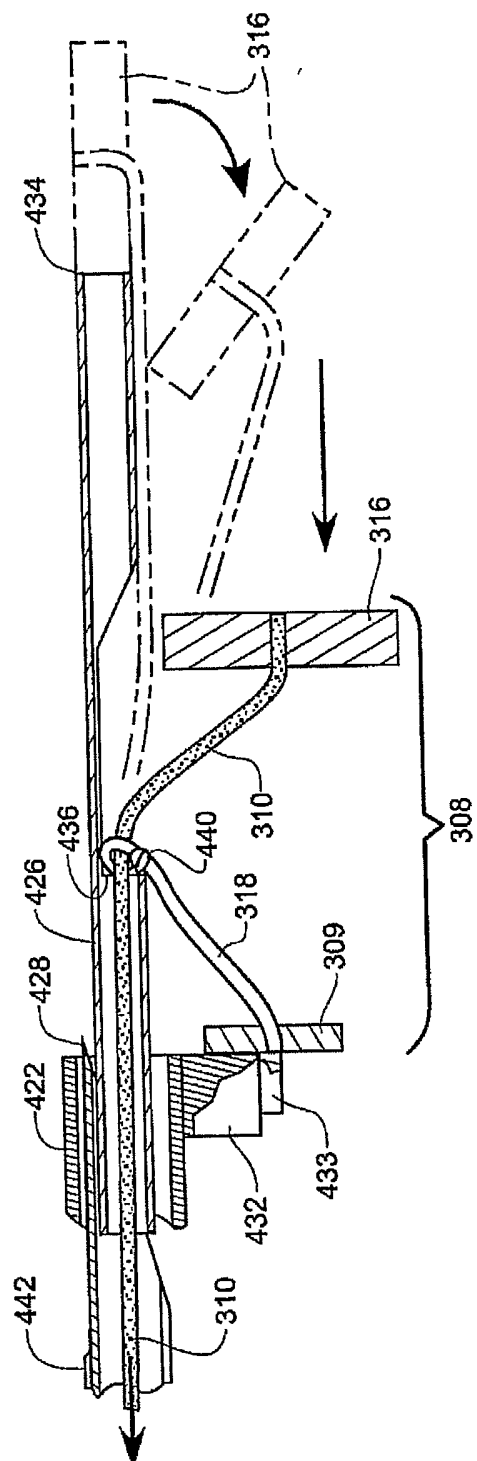
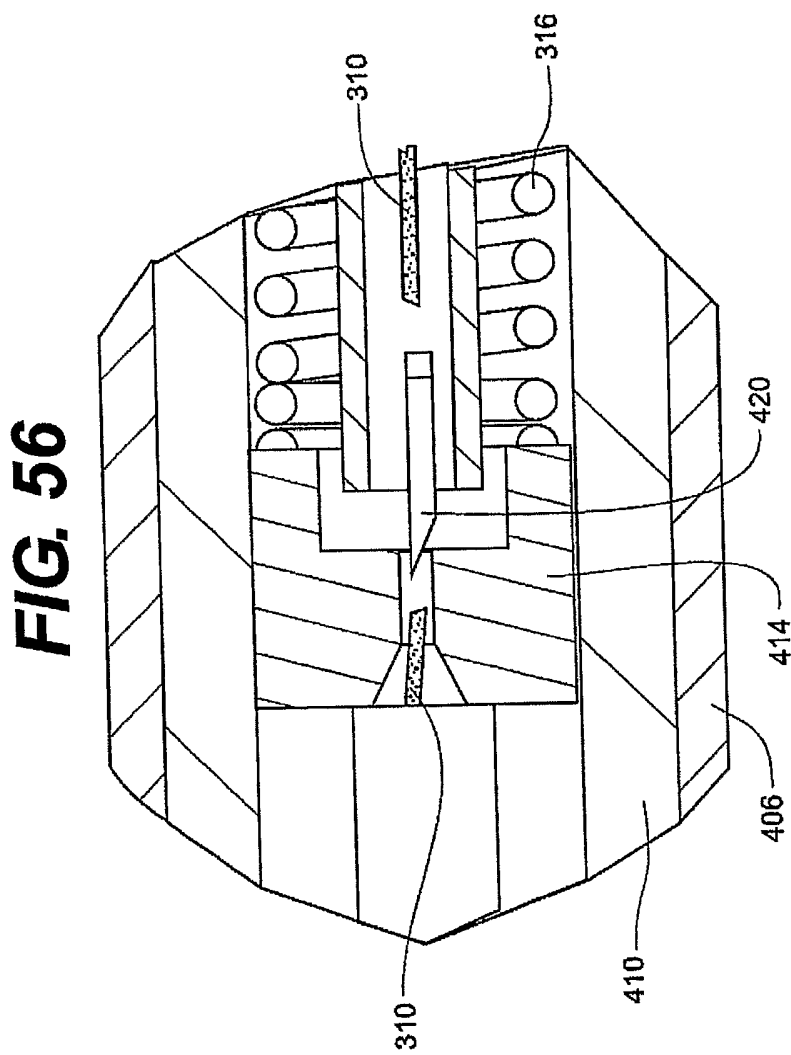
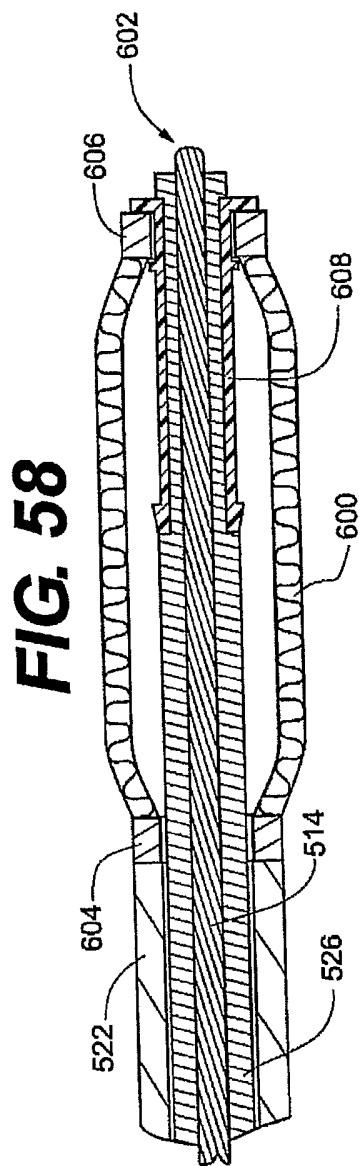
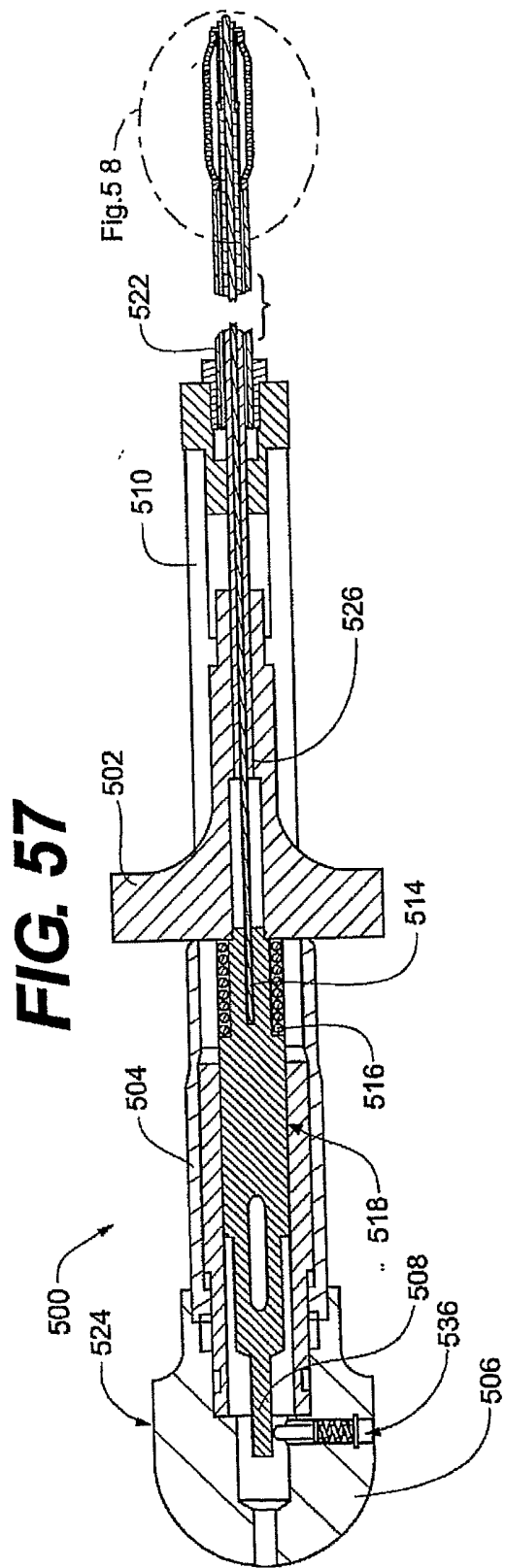

FIG. 55





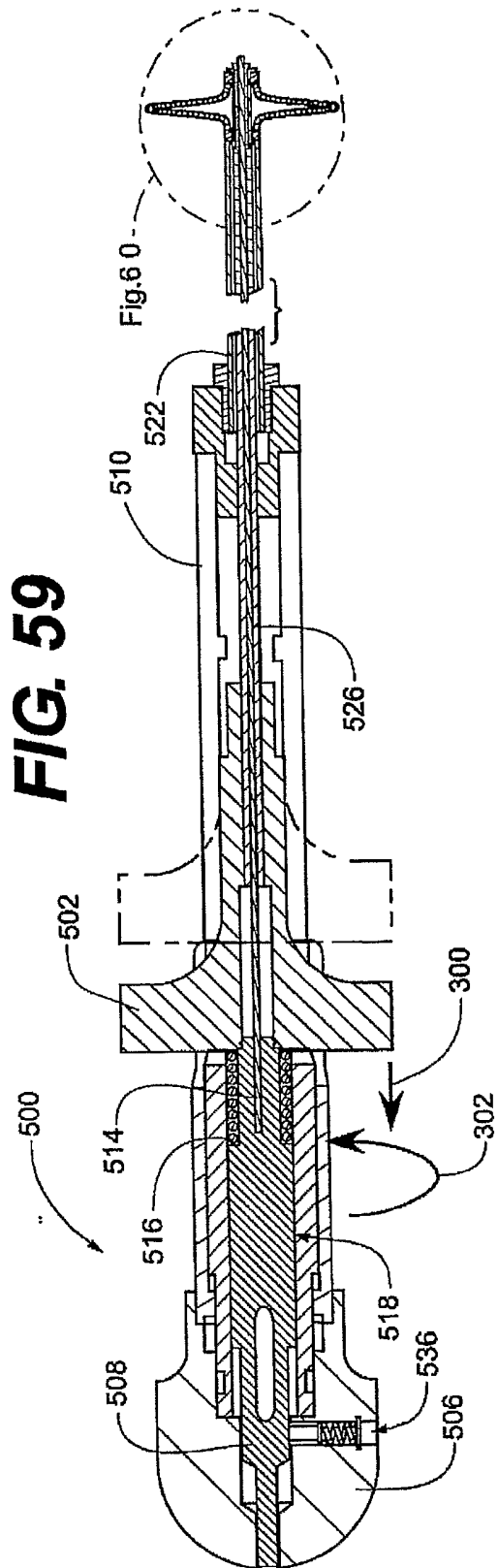

FIG. 59

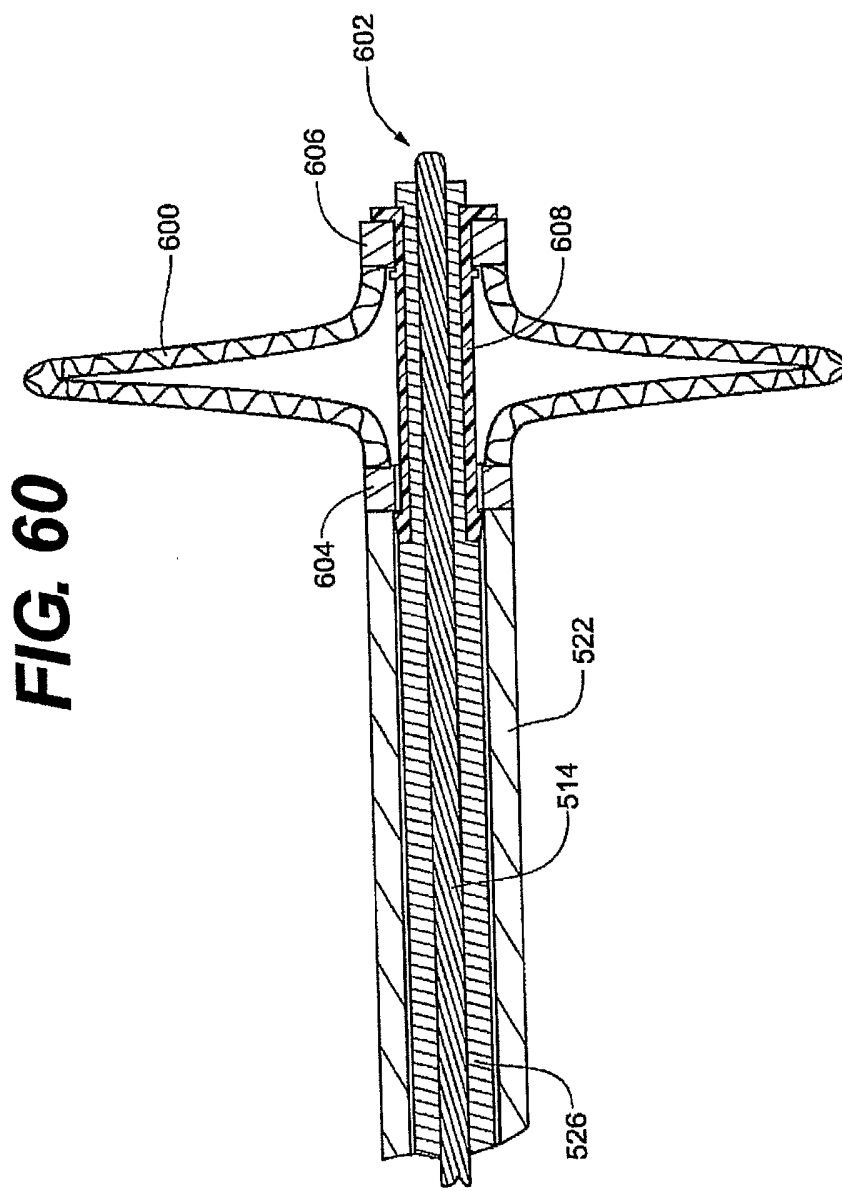
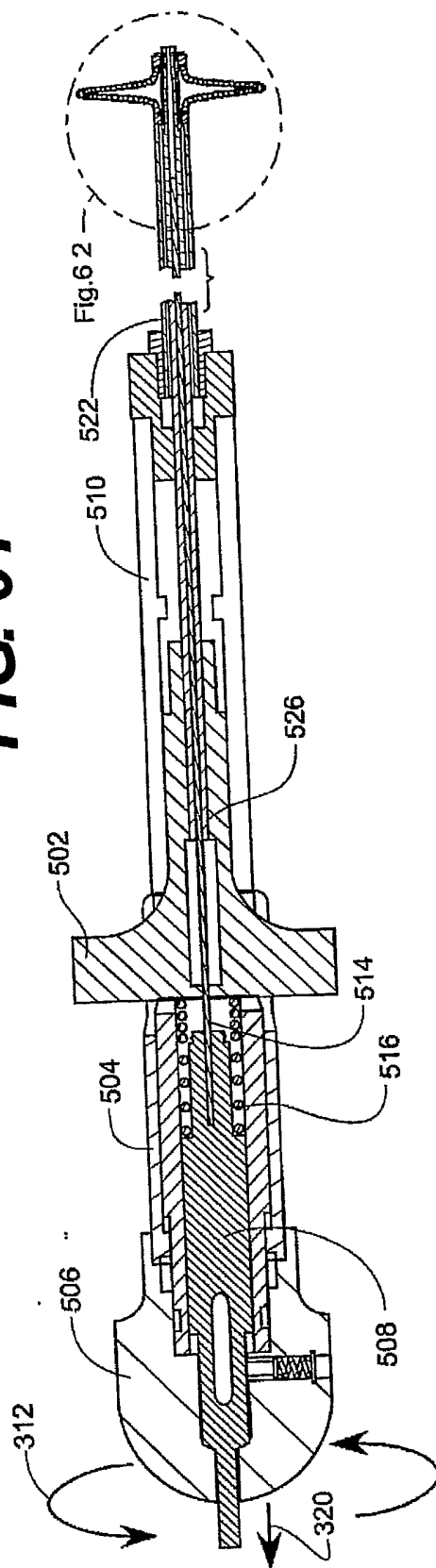

FIG. 60

FIG. 61



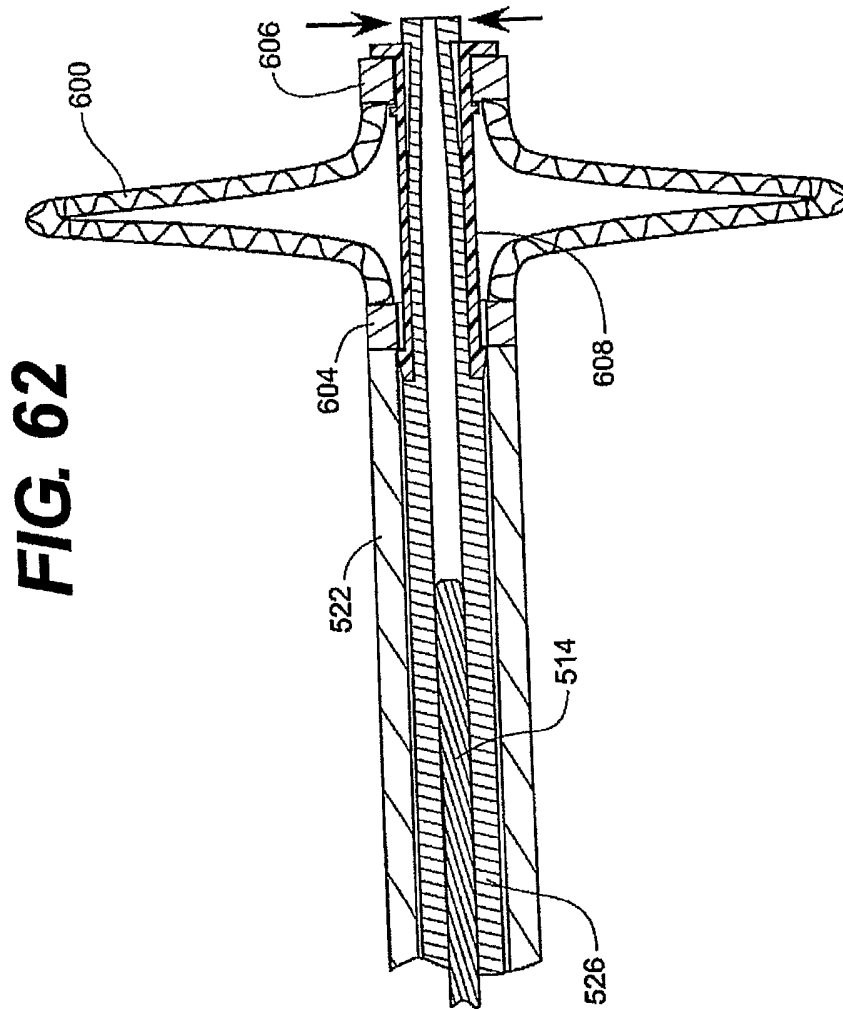

FIG. 62

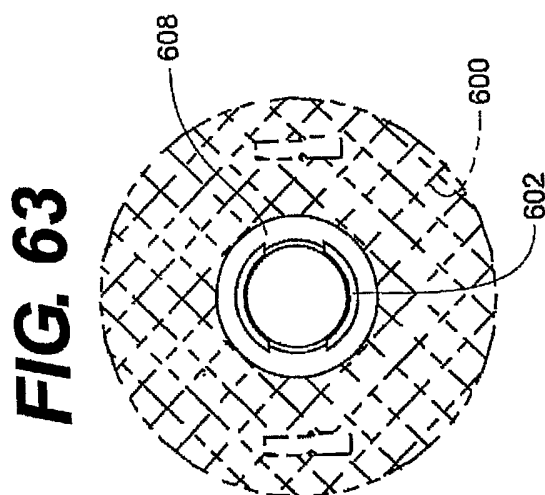
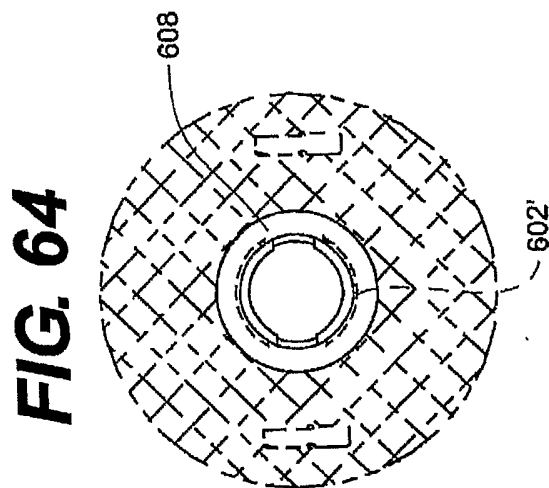

FIG. 65

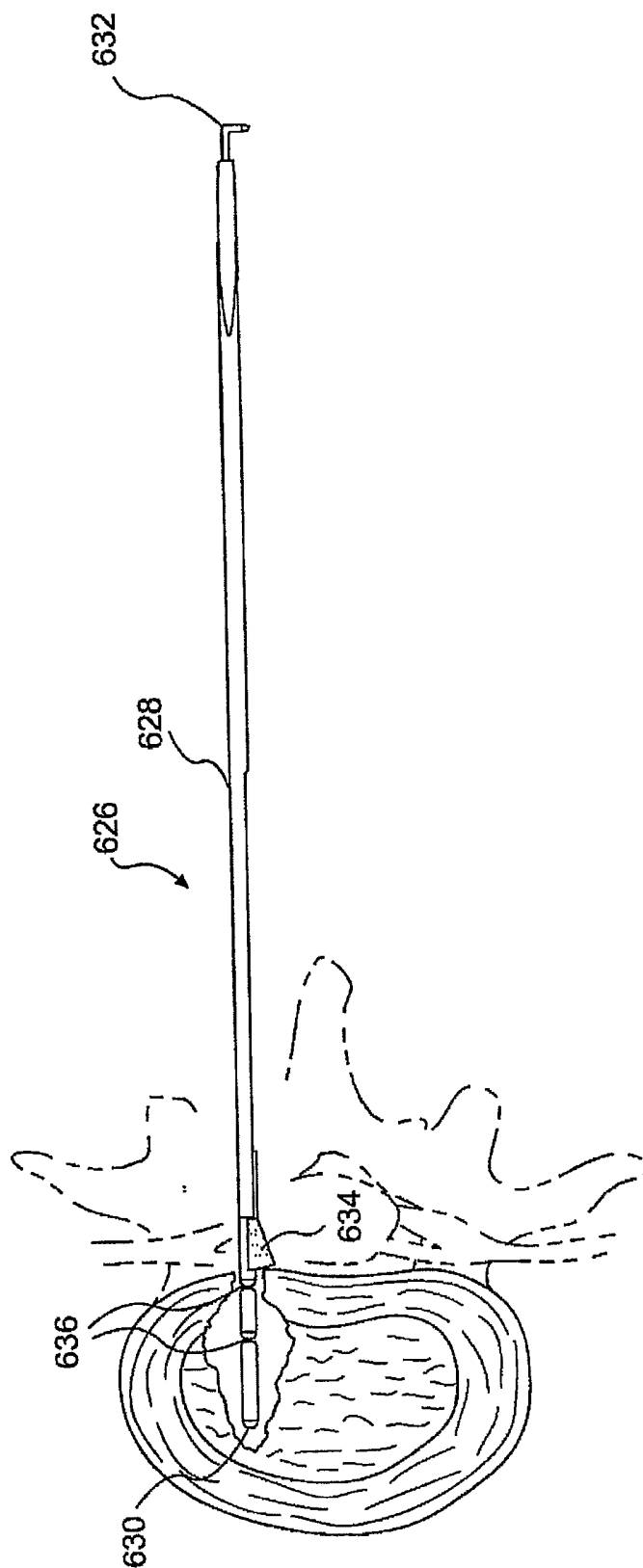

FIG. 66C

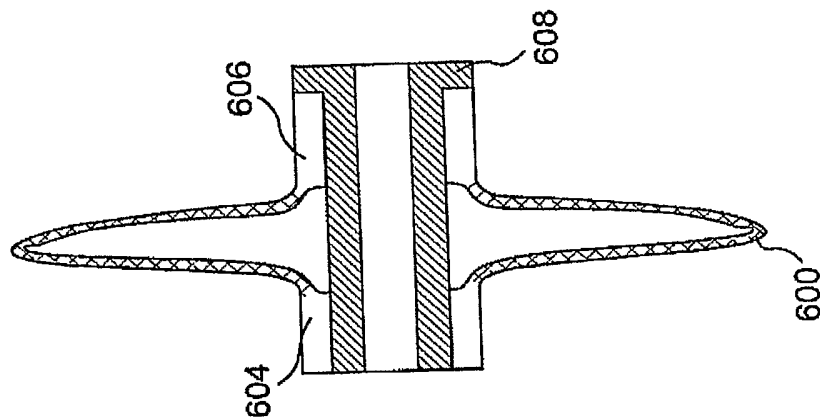

FIG. 66B

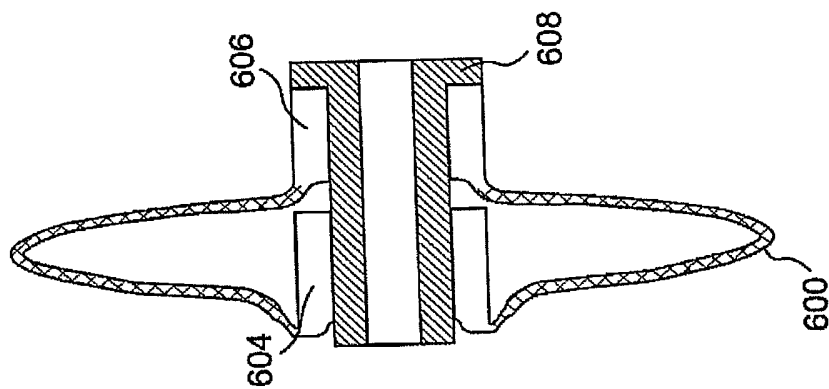

FIG. 66A

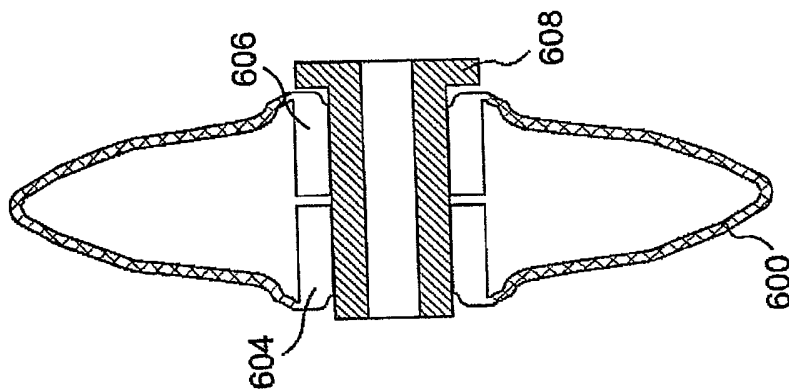

FIG. 67

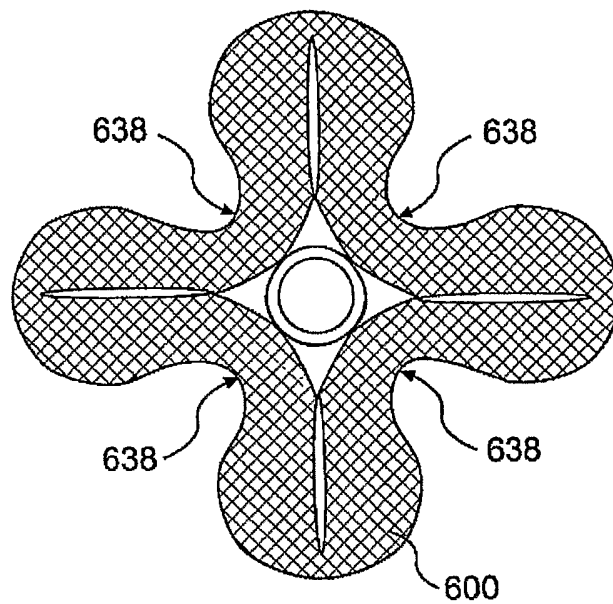

FIG. 68A

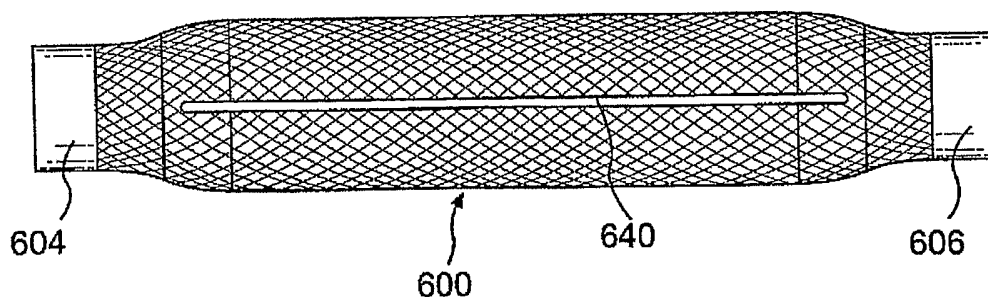

FIG. 68B

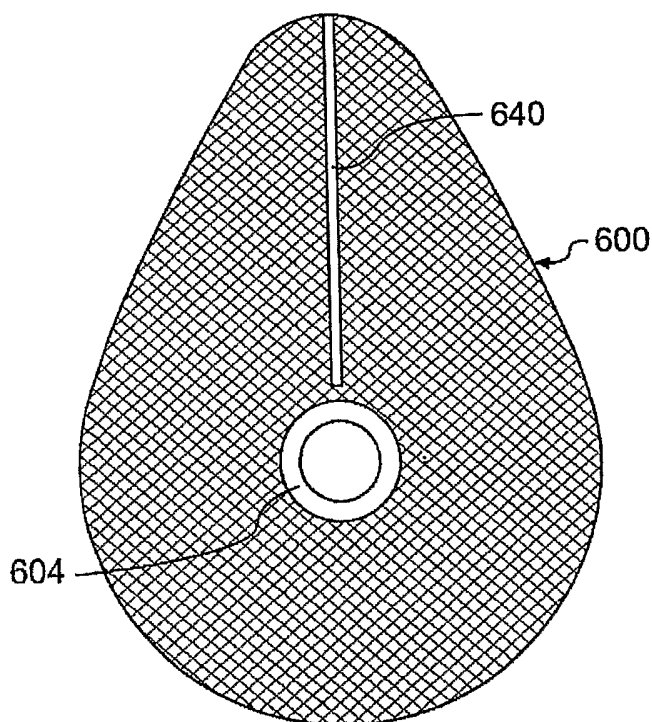

FIG. 69A

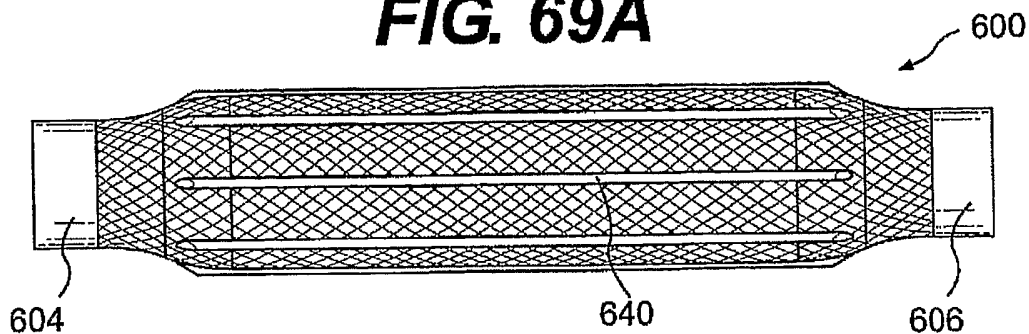

FIG. 69B

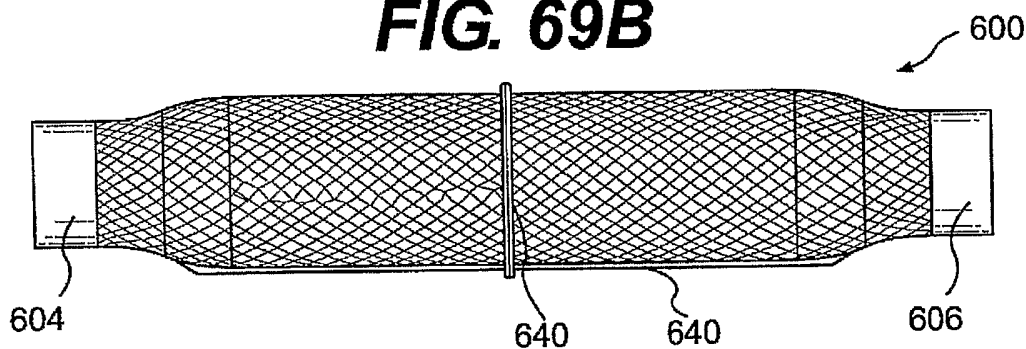

FIG. 69C

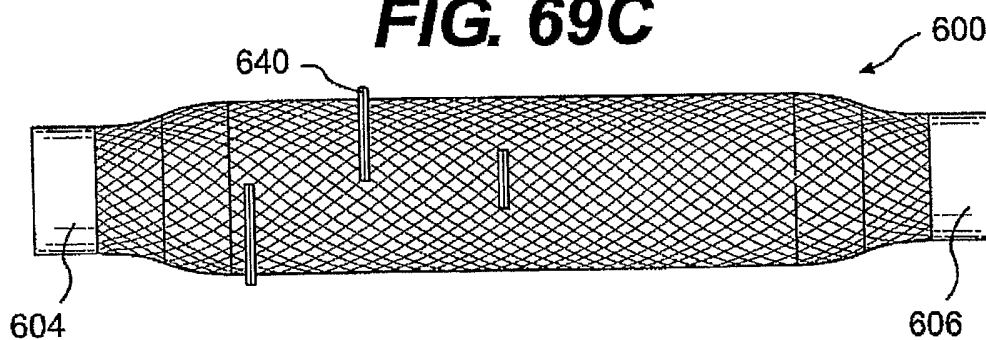
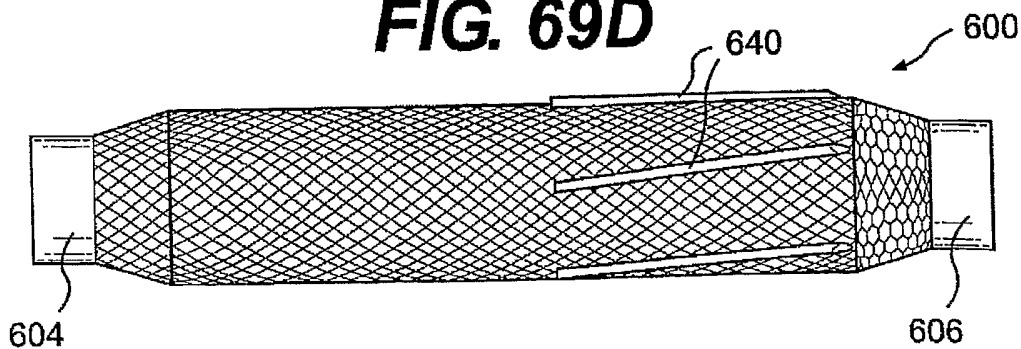

FIG. 69D



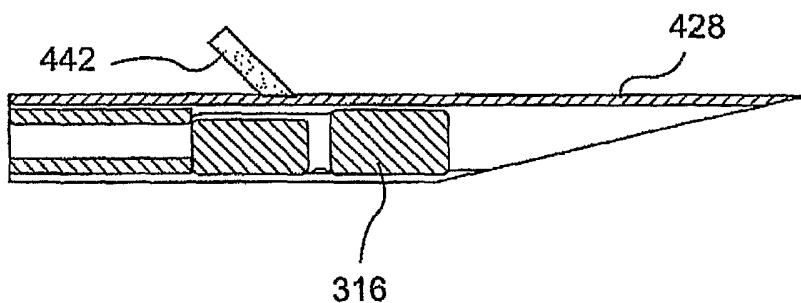

FIG. 70A

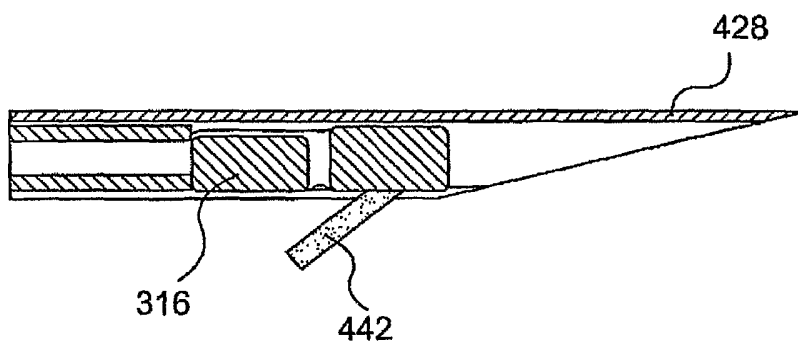

FIG. 70B

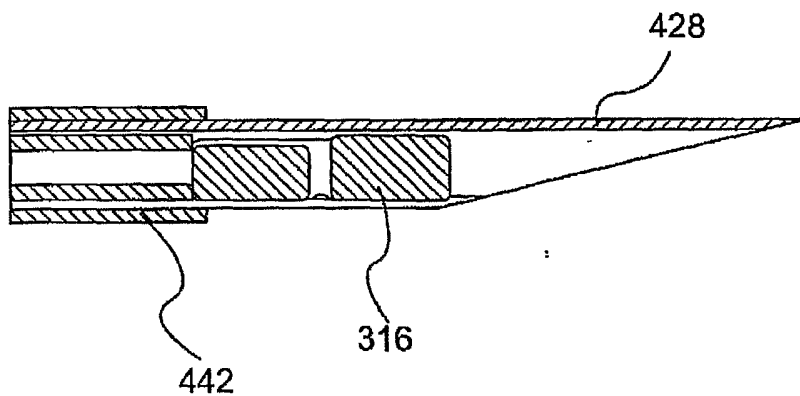

FIG. 70C

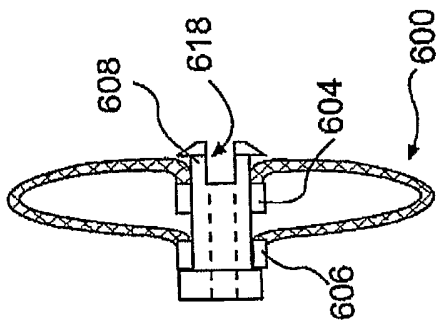

FIG. 71C

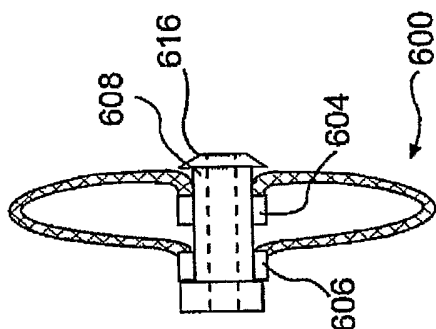

FIG. 71B

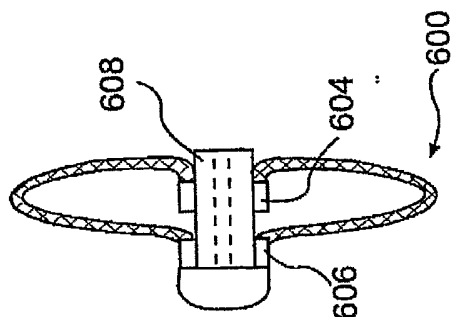

FIG. 71A

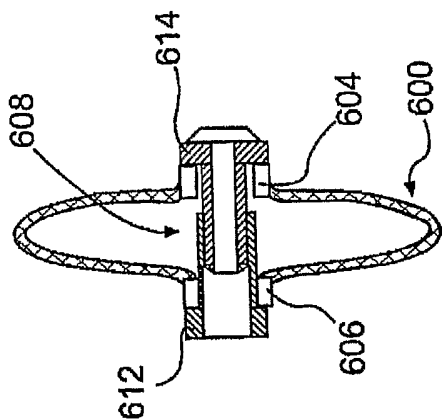

FIG. 71F

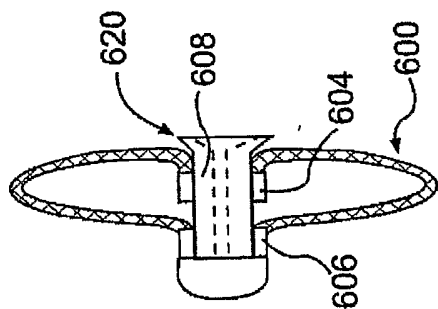

FIG. 71E

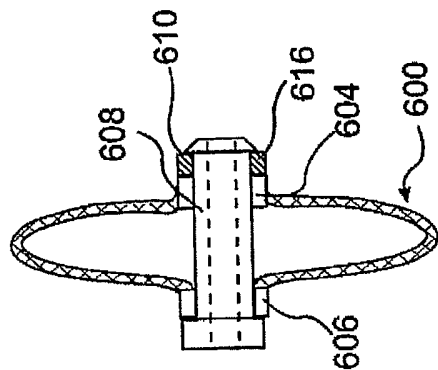

FIG. 71D

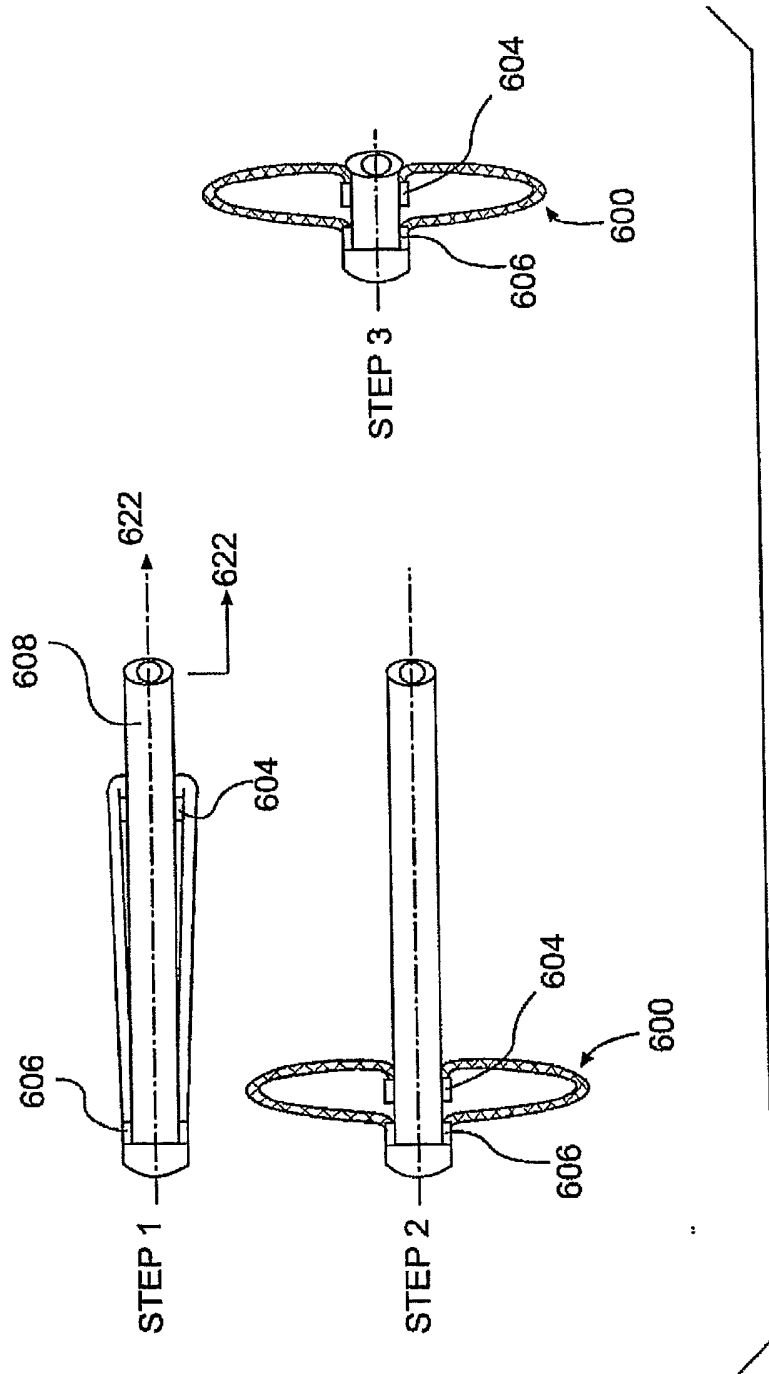

FIG. 71G

FIG. 72A

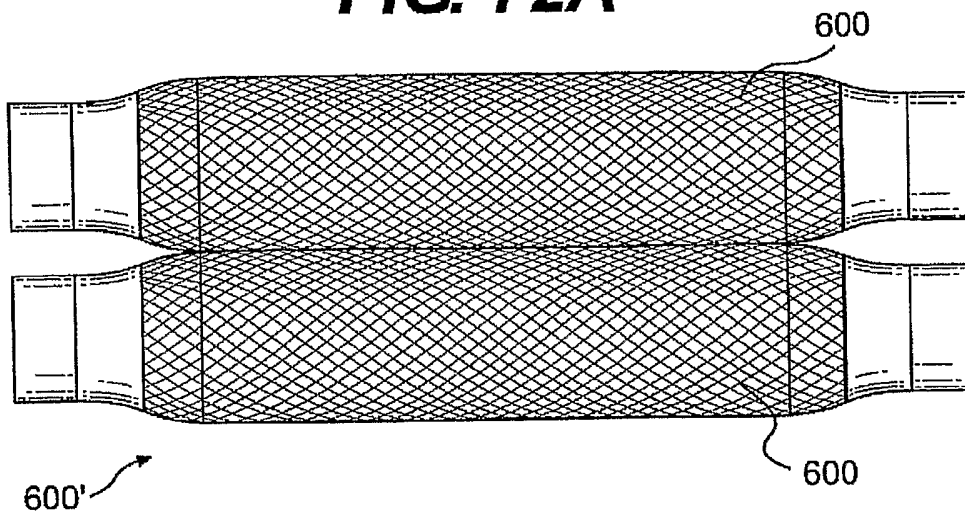

FIG. 72B

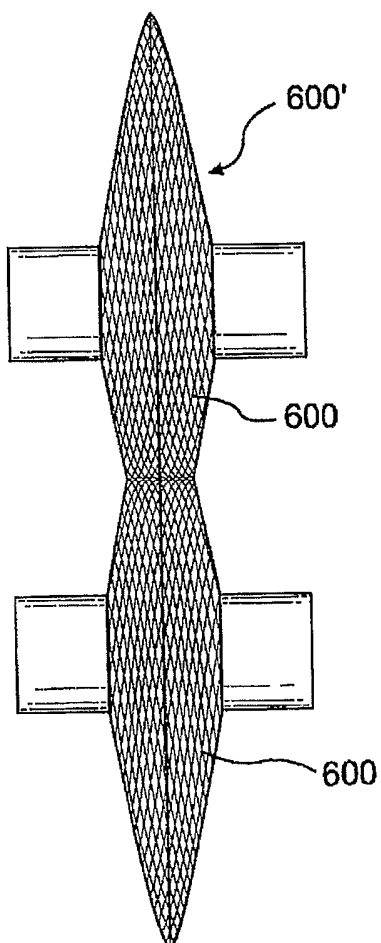

FIG. 73A

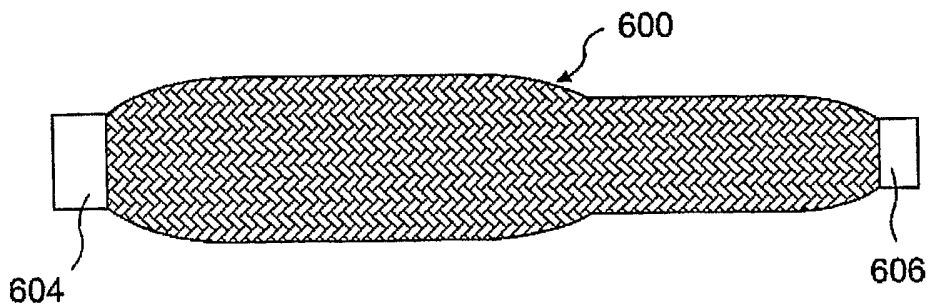

FIG. 73B

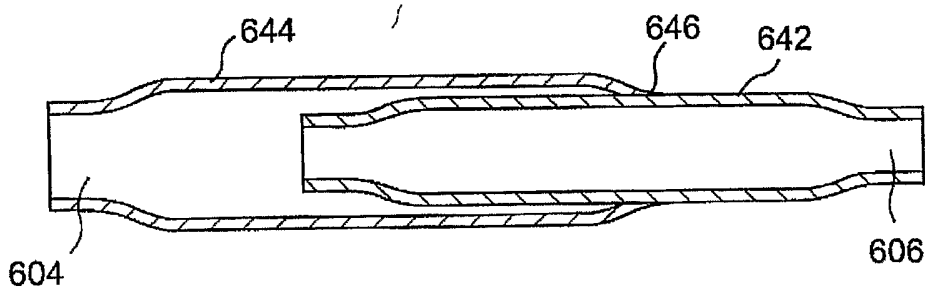
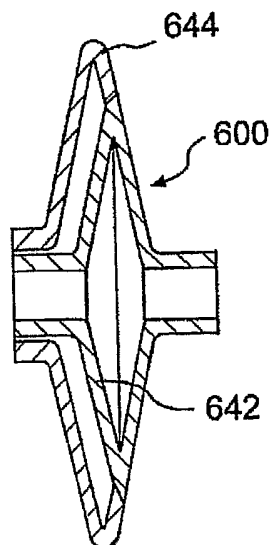

FIG. 73C



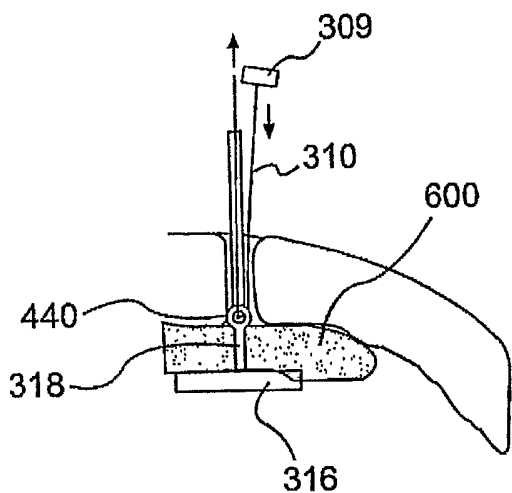

FIG. 74A

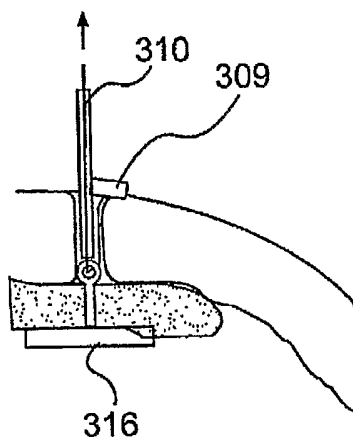

FIG. 74B

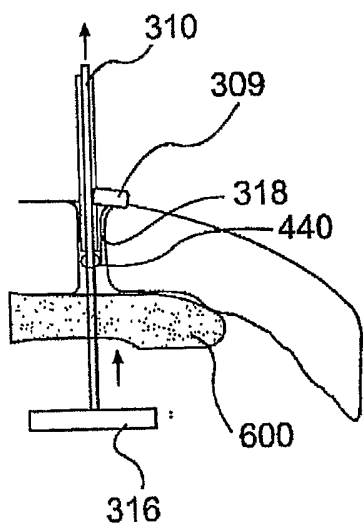

FIG. 75A

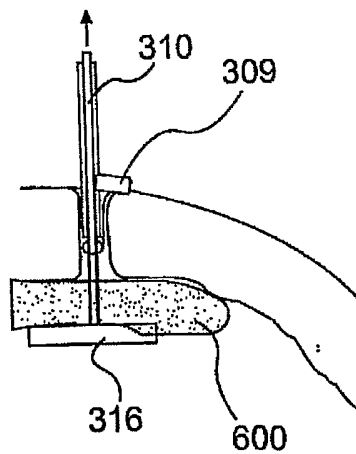

FIG. 75B

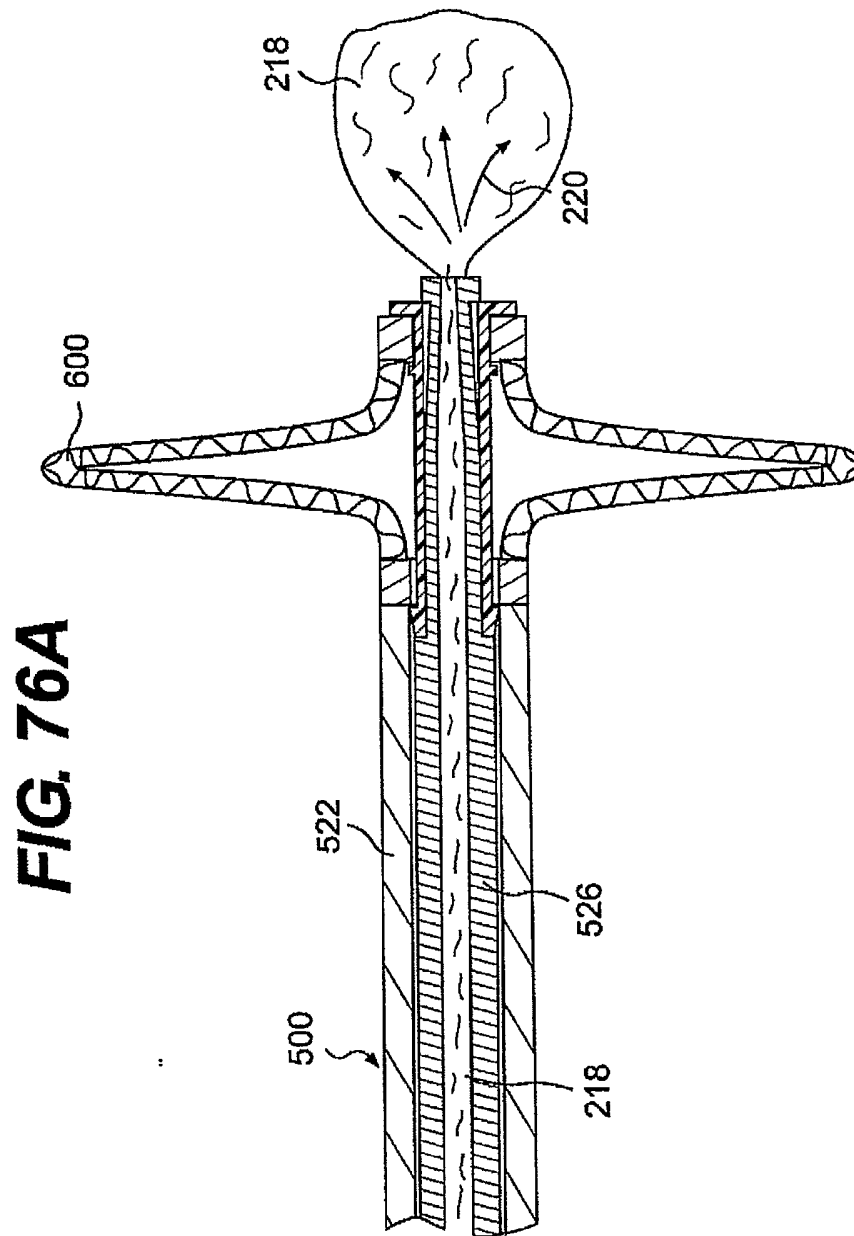

FIG. 76A

FIG. 76B

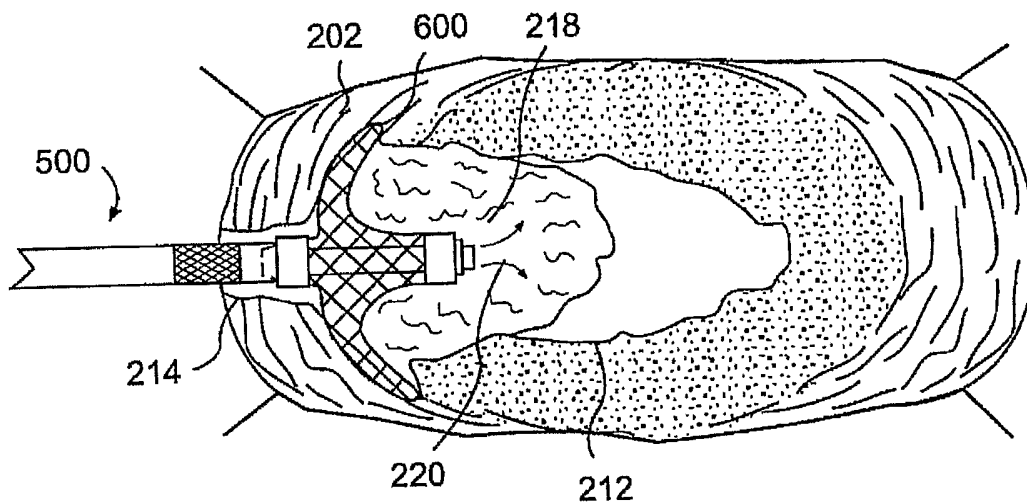

FIG. 77

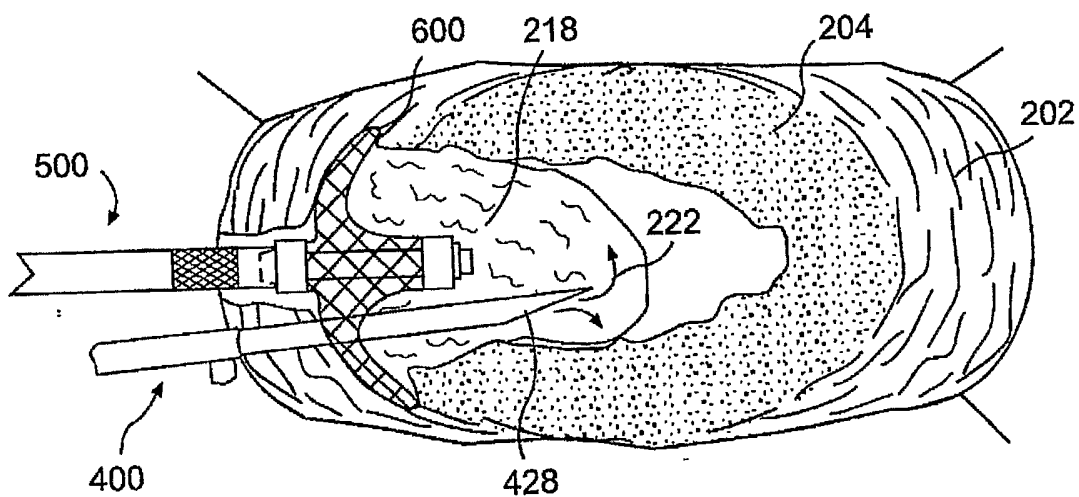

FIG. 78A

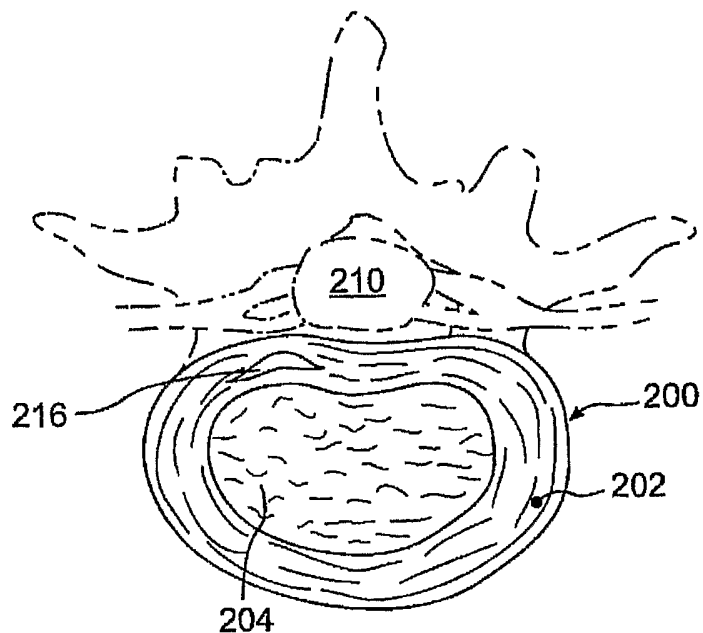
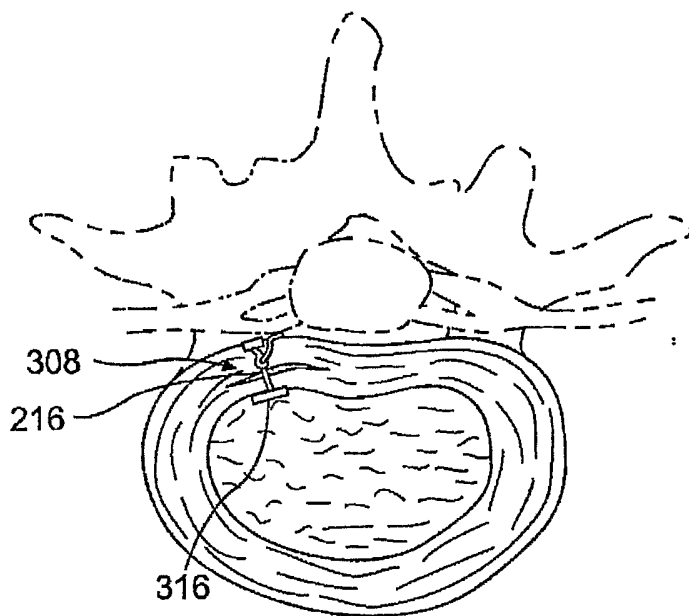

FIG. 78B



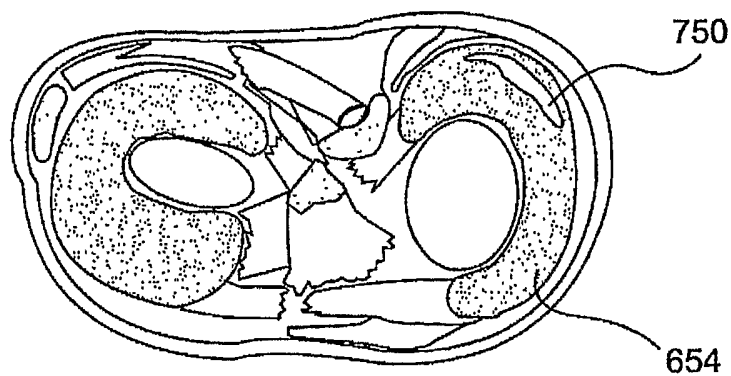

FIG. 79A

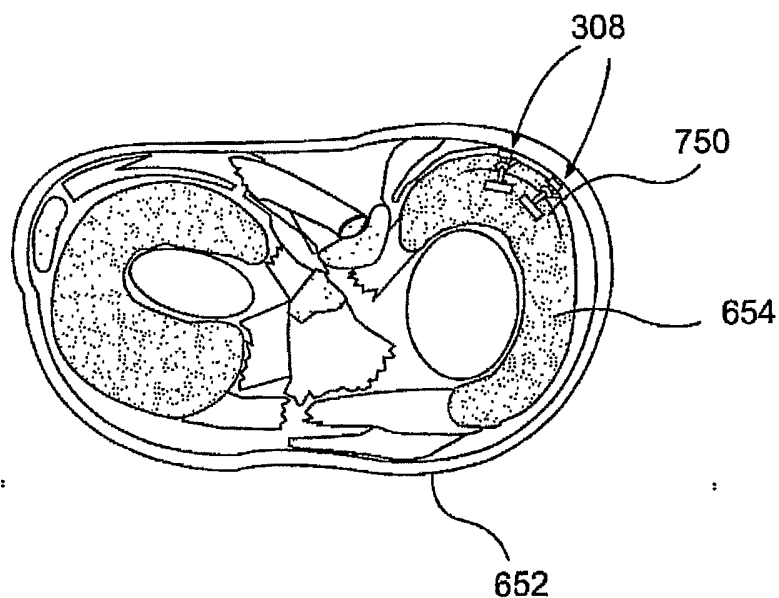

FIG. 79B

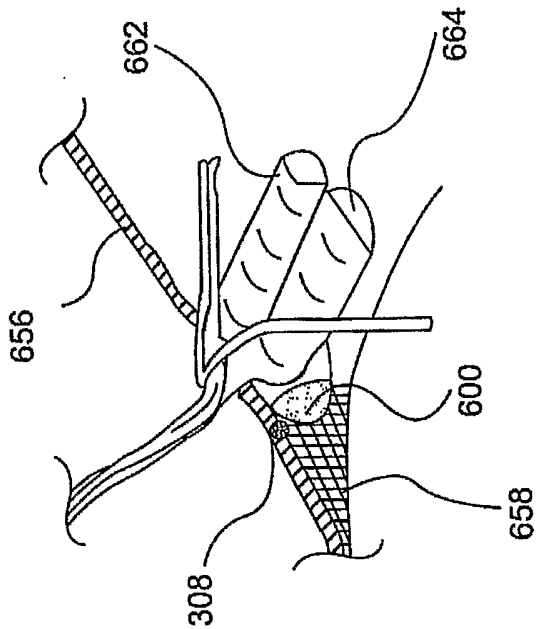

FIG. 80B

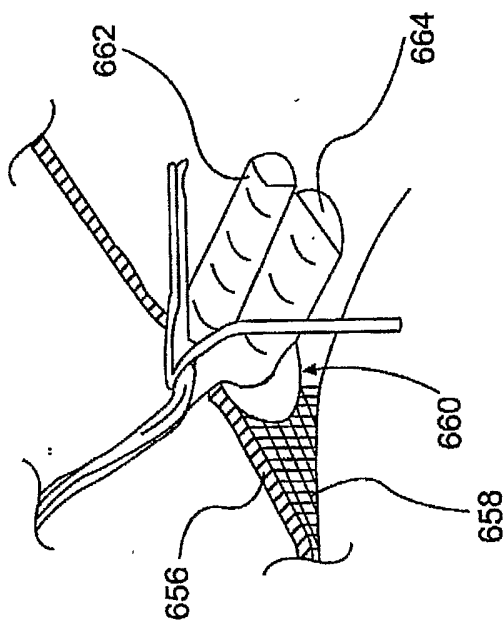

FIG. 80A