

(19) World Intellectual Property
Organization
International Bureau



(43) International Publication Date
6 May 2004 (06.05.2004)

PCT

(10) International Publication Number
WO 2004/037309 A1

- (51) International Patent Classification⁷: **A61L 29/12**, 31/12, B32B 7/10
- (21) International Application Number: PCT/US2003/020861
- (22) International Filing Date: 1 July 2003 (01.07.2003)
- (25) Filing Language: English
- (26) Publication Language: English
- (30) Priority Data:
10/274,633 21 October 2002 (21.10.2002) US
- (71) Applicant: **SCIMED LIFE SYSTEMS, INC.** [US/US];
One SciMed Place, Maple Grove, MN 55311-1566 (US).
- (72) Inventors: **ST. PIERRE, Ernest, J.**; 3 Canadian Geese Road, South Attleboro, MA 02703 (US). **SAHATJIAN, Ronald, A.**; 29 Saddle Club Road, Lexington, MA 02173 (US). **DAYTON, Peter, L.**; 125 Pleasant Street, #307, Brookline, MA 02446 (US). **VAFIADES, David**; 13 Balsam Drive, Bedford, MA 01730 (US).
- (74) Agent: **GAGEL, John, J.**; Fish & Richardson P.C., 225 Franklin Street, Boston, MA 02110-2804 (US).
- (81) Designated States (*national*): AE, AL, AM, AT, AU, AZ, BA, BB, BG, BR, BY, CA, CH, CN, CR, CU, CZ, DE, DK, DM, EE, ES, FI, GB, GD, GE, GH, GM, HR, HU, ID, IL, IN, IS, JP, KE, KG, KP, KR, KZ, LC, LK, LR, LS, LT, LU, LV, MA, MD, MG, MK, MN, MW, MX, NO, NZ, PL, PT, RO, RU, SD, SE, SG, SK, SL, TJ, TM, TR, TT, TZ, UA, UG, UZ, VN, YU, ZA, ZW.
- (84) Designated States (*regional*): ARIPO patent (GH, GM, KE, LS, MW, MZ, SD, SL, SZ, TZ, UG, ZM, ZW), Eurasian patent (AM, AZ, BY, KG, KZ, MD, RU, TJ, TM), European patent (AT, BE, BG, CH, CY, CZ, DE, DK, EE, ES, FI, FR, GB, GR, HU, IE, IT, LU, MC, NL, PT, RO, SE, SI, SK, TR), OAPI patent (BF, BJ, CF, CG, CI, CM, GA, GN, GQ, GW, ML, MR, NE, SN, TD, TG).
- Published:**
— with international search report
- For two-letter codes and other abbreviations, refer to the "Guidance Notes on Codes and Abbreviations" appearing at the beginning of each regular issue of the PCT Gazette.*



WO 2004/037309 A1

(54) Title: COEXTRUDED MULTILAYER MEDICAL DEVICE COMPRISING POLYESTER, POLYAMIDE AND ADHESIVE MATERIAL LAYERS

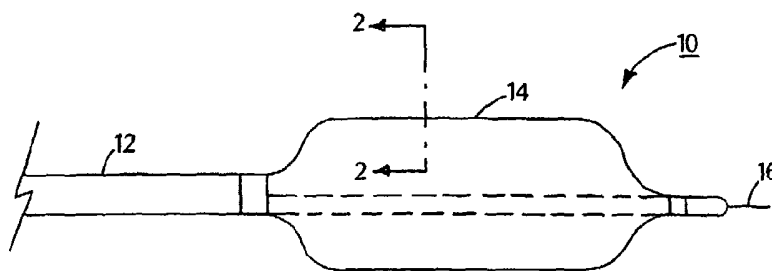

(57) Abstract: Multilayer medical devices, apparatuses for making such devices, and methods of making such devices are disclosed.

COEXTRUDED MULTILAYER MEDICAL DEVICE COMPRISING POLYESTER, POLYAMIDE AND ADHESIVE MATERIAL LAYERS

TECHNICAL FIELD

This invention relates to multilayer medical devices, such as multi-layer balloons.

5

BACKGROUND

Medical procedures can utilize a balloon in different ways. As an example, in some procedures a balloon is used to open an occluded lumen, as in angioplasty. As another example, in certain procedures a balloon is used to position another medical implement, such as a stent or graft, within a lumen. As an additional example, a balloon is used to selectively block a passageway. In additional examples, a balloon is used in various combinations of these procedures.

In some cases, the balloon is positioned on the end of a catheter shaft. The balloon is typically wrapped around the catheter shaft to reduce the radial profile for easier insertion. The catheter is then threaded through the body to position the balloon at a location of treatment and the balloon is inflated. Finally, the balloon is deflated and the catheter is withdrawn from the body.

15

SUMMARY

The invention relates to multi-layer medical devices, such as multi-layer balloons.

20

In one aspect, the invention features a medical device having a wall. The wall includes a first layer including a polyester or a polyester copolymer, a second layer including a polyamide or a polyamide copolymer, and a third layer including an adhesive material. The first, second and third layers are coextruded.

In another aspect, the invention features a medical device having a wall. The wall includes a first layer including a polyester or a polyester copolymer, a second layer including a polyamide or a polyamide copolymer, and a third layer including an adhesive material. The thickness of the first layer is at least about 50 percent of a total thickness of the wall.

25

In a further aspect, the invention features a medical device having a wall. The wall includes a first layer including a polyester or a polyester copolymer, a second layer including a polyamide or a polyamide copolymer, and a third layer including an adhesive material. The thickness of the third layer is less than about 20 percent of a total thickness of the wall.

30

In one aspect, the invention features a medical device having a wall. The wall includes a first layer including a polyester or a polyester copolymer, a second layer including a polyamide or a polyamide copolymer, and a third layer including an adhesive material. The third layer is less than about 0.005 inch thick.

5 In another aspect, the invention features a method of forming a tube. The method includes coextruding first second and third materials to form a wall of the tube with first, second and third layers. The first layer includes a polyester or a polyester copolymer. The second layer includes a polyamide or a polyamide copolymer, and the third layer includes an adhesive material.

10 In a further aspect, the invention features a method of forming a tube. The method includes coextruding multiple polymer layers to form a wall of the tube, and forming the tube into a balloon. The method also includes heating the balloon to a temperature of at least about 50°C at a pressure of at least about 50 pounds per square inch.

15 In one aspect, the invention features an extrusion apparatus. The apparatus includes at least three extruders, and a cross-head in fluid communication with the extruders. The cross-head is capable of holding from about 3.2 cubic centimeters to about five cubic centimeters of a fluid from one of the first extruders.

In another aspect, the invention features an extrusion apparatus that includes a
20 at least three extruders, and a cross-head in fluid communication with the extruders. The cross-head is capable of holding from about two cubic centimeters to about four cubic centimeters of a fluid from one of the extruders.

In a further aspect, the invention features an extrusion apparatus that includes at
25 least three extruders, and a cross-head in fluid communication with the first, second and third extruders. The cross-head is capable of holding from about three cubic centimeters to about 4.5 cubic centimeters of a fluid from one of the extruders.

In certain embodiments, the coextruded polymer wall structure can provide a medical device, such as a balloon, with desirable properties. For example, the medical device can exhibit good hoop strength, toughness, crack resistance, compliance,
30 resistance to delamination and resistance to pinhole formation, while at the same time providing relatively high burst strength and desired dispensability, typically using substantially crystalline, biaxially oriented polymers. While such properties can be advantageous for any size medical device, the properties can be particularly

advantageous for relatively large balloons (e.g., balloons having an inflated diameter of more than about four millimeters, such as more than about 4.25 millimeters, more than about 4.5 millimeters).

In some embodiments, the medical device (e.g., balloon) can undergo no
5 substantial physical degradation when subjected to conditions that are as stressful or more stressful than the intended use conditions of the medical device.

Features, objects and advantages of the invention are in the description, drawings and claims.

DESCRIPTION OF DRAWINGS

10 Fig. 1 is a side view of an embodiment of a balloon catheter system;

Fig. 2 is a cross-section through a section of a wall of a multi-layer balloon taken along the line 2-2 in Fig. 1;

Fig. 3 is a schematic diagram of steps in an embodiment of a process for forming a balloon;

15 Fig. 4 is a schematic diagram of steps in an embodiment a process for forming a tube;

Figs. 5 is a schematic view of an embodiment of an extrusion apparatus; and

Fig. 6 is a cross-sectional view of an embodiment of a cross-head.

DETAILED DESCRIPTION

20 Fig. 1 shows an embodiment of a balloon catheter system 10 including a catheter shaft 12 carrying an inflatable multi-layer balloon 14. A guide wire 16 can be used to deliver balloon 14 to a treatment area (e.g., a coronary artery). Examples of catheter systems are described in, for example, U.S. Patent Nos. 5,195,969 and 5,270,086, which are hereby incorporated by reference. An example of a balloon
25 catheter system is the Ranger[®] system, commercially available from Boston Scientific Scimed, Maple Grove, MN.

Fig. 2 is a cross-sectional view of a wall 18 of balloon 14. Wall 18 includes coextensively coextruded polymer layers 20, 22 and 24, which are formed of a polyester, an adhesive and a polyamide, respectively.

30 In general, layer 20 can be formed of any polyester-containing material (e.g., a substantially pure polyester, a blend containing at least one polyester, a polyester copolymer) appropriate for use in a medical device. Such polymers include, for example, polyester homopolymers and/or copolymers (e.g., block copolymers) of

polyesters. Examples of polyesters include the polyethylene terephthalate (PET) polymers, polybutylene terephthalate (PBT) polymers and blends and combinations thereof. Examples of commercially available polyesters include the Selar PT family of polymers (e.g., Selar PT 8307, Selar PT4274, Selar PTX280), which are commercially available from E. I. DuPont de Nemours (Wilmington, DE), the Cleartuf family of polymers (e.g., Cleartuf 8006), which are commercially available from M&G Polymers (Apple Grove, WV), the Traytuf family of polymers (e.g., Traytuff 1006), which are commercially available from the Shell Chemical (Houston, TX), the Melinar family of polymers, commercially available from E. I. DuPont de Nemours (Wilmington, DE), the Celanex family of polymers, commercially available from Ticona (Summit, NJ), the Riteflex family of polymers, commercially available from Ticona (Summit, NJ), the Hytrel family of polymers (e.g., Hytrel 5556, Hytrel 7246, Hytrel 4056), commercially available from E. I. DuPont de Nemours (Wilmington, DE), and the Arnitel family of polymers (e.g., Arnitel EM630), commercially available from DSM (Erionspilla, IN).

Generally, layer 22 can be formed any adhesive material appropriate for use in a medical device. Typically, the adhesive is a polymer (e.g., a substantially pure polymer, or a blend of polymers). In general, an adhesive refers to a material that is capable of forming a bond with its adjacent layers of materials so that the resulting multilayer device (e.g., a medical device, such as a tube or balloon catheter) can be used for its intended purpose. Preferred adhesive materials maintain their desired adhesive properties (e.g., undergo substantially no chemical degradation) when exposed to process conditions described herein. As an example, in certain embodiments, layer 22 is formed of an ethylene vinyl acetate polymer-containing material, such as a functionalized ethylene vinyl acetate copolymer (e.g., an ethylene vinyl acetate copolymer containing maleic anhydride groups, an ethylene vinyl acetate copolymer containing glycidyl methacrylate groups). As another example, in some embodiments, layer 22 is formed of an anhydride-modified polyolefin. An adhesive can be selected, for example, from the Bynel family of polymers (e.g., Bynel CXA Series, Bynel 1000 Series, Bynel 1123, Bynel 1124, Bynel 11E554, Bynel 11E573, Bynel CXA E-418), commercially available from E. I. DuPont de Nemours (Wilmington, DE), the Plexar family of polymers (e.g., PX360, PX360E, PX380, PX3227, PX3236, PX3277, PX5125, PX5327, PX206, PX209, PX2049, PX165, PX175, PX180, PX909, PX101, PX107A, PX108, PX114, PX1164), commercially available from Equistar Chemicals

(Newark, NJ), and/or the BLOX family of polymers (e.g., BLOX 200 Series), commercially available from the Dow Chemical Company (Midland, MI).

In general, layer 24 can be formed of any polyamide-containing material (e.g., a substantially pure polyamide, a blend containing at least one polyamide) appropriate for use in a medical device. Such polymers include, for example, polyamide homopolymers and/or copolymers (e.g., block copolymers) of polyamides. One type of polyamide includes the nylon family of polymers, including, for example, aliphatic nylons and aromatic nylons. A nonlimiting list of exemplary nylons includes Nylon 12, commercially available from Atofina (Philadelphia, PA), Nylon 6, commercially available from Honeywell (Morristown, NJ), Nylon 6/10, commercially available from BASF (Mount Olive, NJ), Nylon 6/12, commercially available from Ashley Polymers (Cranford, NJ), Nylon 11, Nylon MXD-6, the Grivory family of polymers, commercially available from EMS (Sumter, SC), the Grilamid family of polymers, commercially available from EMS (Sumter, SC), and the Vestamid family of polymers, commercially available from Daicel-Degussa Ltd. Additional polyamides include the Pebax family of polymers (e.g., Pebax 5533, Pebax 2533, Pebax 7033), commercially available from Atofina (Philadelphia, PA) and the Trogamid family from Daicel-Degussa.

One or more of the layers of wall 18 can contain additional material(s). For example, one or more layers of wall 18 can contain one or more additional polymers (e.g., blended therewith), such as liquid crystal polymer(s) (LCPs), polyester(s), polyamide(s), and/or their copolymers. Examples of such materials include the Vectra family of polymers (e.g., Vectra A, Vectra B, Vectra LKX, Vectra LKX 1111) and the Vectran family of polymers (e.g. Vectran V300P), both commercially available from Ticona (Summit, NJ), acrylonitrile-butadiene-styrenes (ABSs), ABS/nylon, ABS/-polyvinyl chlorides (PVCs), ABS/polycarbonate, acrylonitrile copolymers, polyacrylates, polyacrylsulfones, polyethylene naphthalates (PENs), polyetheretherketones (PEEKs), polyethersulfones (PESs), polyetherimides (PEIs), polyetherketones (PEKs), polymethylpentenes, polyphenylene ether, polyphenylene sulfides styrene acrylonitriles (SANs), propylene ethylene vinylacetate, ethylene vinyl alcohols (EVAs), ionomeric polymers, polyethylene type I-IVs, polyolefins, polyurethanes, PVCs, polysiloxanes (silicones), fluorocarbons, such as polychlorotrifluoroethylenes (CTFEs), poly[ethylene-co-chlorotrifluoroethylene]s

(ECTFEs) copolymer ethylene tetrafluoroethylenes (ETFEs), copolymer tetrafluoroethylenes, hexafluoropropylenes (FEPs), perfluoroalkanes (PFAs), and poly[vinylidene fluoride]s (PVDF)s.

The thickness of layers 20, 22 and 24 can be varied as desired.

5 In certain embodiments, the thickness of layer 20 is at least about 50 percent (e.g., at least about 60 percent, at least 70 percent, at least 80 percent) of the total thickness of wall 18. In some embodiments, the thickness of layer 20 is less than about 90 percent (e.g., less than about 80 percent, less than about 70 percent, less than about 60 percent) of the total thickness of wall 18.

10 In certain embodiments, the thickness of layer 24 is at least about one percent (e.g., at least about two percent, at least about five percent, at least about 10 percent, at least about 20 percent, at least about 30 percent, at least about 40 percent) of the total thickness of wall 18. In some embodiments, the thickness of layer 24 is less than about 50 percent (e.g., less than about 40 percent, less than about 30 percent, less than about 20 percent, less than about 10 percent, less than about five percent, less than about two percent) of the total thickness of wall 18.

In some embodiments, layer 22 has a thickness of less than about 0.005 inch (e.g., less than about 0.004 inch, less than about 0.003 inch, less than about 0.002 inch, less than about 0.001 inch, less than about 0.0005 inch, less than about 0.0004 inch, less than about 0.0003 inch, less than about 0.0002 inch, less than about 0.0001 inch, less than about 0.00005 inch).

In general, the balloons can be of any desired shape and size (e.g., coronary balloons, aortic balloons, peripheral balloons, reperfusion balloons, endoscopy balloons, urology balloons and neurology balloons). In certain embodiments, a coronary balloon can have a diameter of from about 1.5 millimeters to about six millimeters. In some embodiments, a peripheral balloon can have a diameter of from about three millimeters to about 12 millimeters. In certain embodiments, an endoscopy and/or urology balloon can have a diameter of from about four millimeters to about 40 millimeters. In some embodiments, a neurology balloon can have a diameter of from about 1.5 millimeters to about five millimeters.

30 The balloon can have a diameter of, for example, at least about one millimeters (e.g., at least about two millimeters, at least about three millimeters). In certain embodiments, the balloons have a relatively large diameter (e.g., at least about four

millimeters, at least about five millimeters, at least about six millimeters, at least about seven millimeters, at least about eight millimeters, at least about nine millimeters, at least about 10 millimeters, at least about 11 millimeters, at least about 12 millimeters, at least about 20 millimeters, at least about 30 millimeters, at least about 40 millimeters).

In some embodiments, the balloon can have a relatively high burst pressure. For example, the balloon can have a burst pressure of at least about 200 psi (e.g., at least about 225 psi, at least about 250 psi, at least about 275 psi, at least about 300 psi, at least about 325 psi, at least about 350 psi, at least about 375 psi, at least about 400 psi, at least about 425 psi, at least about 450 psi). As referred to herein, the burst pressure of a balloon is determined as follows. The balloon is deflated and submerged in a water bath at 37°C. The balloon is then inflated with water at a rate of about 20 psi per second until the balloon bursts.

In certain embodiments, the balloon can have a relatively high degree of compliance. For example, the balloon can have a compliance of at least about two percent (e.g., at least about 2.25%, at least about 2.5%, at least about 2.75%, at least about three percent, at least about 3.25%, at least about 3.5%). As referred to herein, the degree of compliance of a balloon is determined as follows. The balloon is held at 37°C and inflated first to one atmosphere pressure, and then in increments of one atmosphere pressure while measuring the diameter of the balloon. This is done until the balloon reaches the rated burst pressure or until the balloon bursts. A plot of the results is generated, the slope from four atmospheres pressure to the rated burst pressure is calculated, and is the compliance value (diameter versus pressure).

Fig. 3 is a schematic diagram showing steps in a process 300 for making balloon 14. In a step 310, layers 20, 22 and 24 are coextensively coextruded to form a tube. According to a step 320, a preform is formed from the tube. Layers 20, 22 and 24 in the preform are crystallized (e.g., biaxially oriented) during a step 330. In a step 340, a free form balloon is prepared, and the balloon is optionally subjected to a mold heat set in step 350.

Without wishing to be bound by theory, it is believed that making the coextruded balloons with appropriate physical properties (e.g., good hoop strength, layer adhesion, toughness, and/or crack resistance and resistance to pinhole formation) can involve using an extrusion apparatus and/or extrusion conditions that provide a

residence time and adequate pressure for the polymers that is sufficient for appropriate adhesion to occur between the polymer layers but not so severe so that the polymers undergo undesirable degradation, particularly the adhesive layer material(s).

Fig. 4 is a schematic diagram of a system 400 used during step 310 of process 5 300. System 400 includes an extrusion apparatus 410, a cooling bath 420, a take-off apparatus 430, and a cutter 440. Typically, during tube formation, the material(s) from which layers 20, 22 and 24 are dried and then added to pre-heated extrusion apparatus 410. The materials are allowed to melt and a force is applied to the materials to cause them to be coextensively coextruded into the shape of a tube, and to cause the tube-
10 shaped, coextruded materials exit extrusion apparatus 410. Take-off apparatus 430 draws the tube through bath 420, where the tube is cooled, and then draws the cooled tube to cutter 440, where the tubes are cut into desired lengths.

Fig. 5 is a schematic representation of an embodiment of extrusion apparatus 410 having extruders 412, 414 and 416, and a cross-head 418. Extruders 412, 414 and
15 416 have hoppers 413, 415 and 417, respectively.

Fig. 6 is a cross-sectional view of an embodiment of a cross-head 418. Cross-head 418 has a body 600, a die retainer 610, an inner layer flow divider 620, a middle layer flow divider 630, an outer layer flow divider 640, bolts 650 and 660, divider alignment pins 670, 680 and 690, a tip 700, a die 710, a tip retainer 720, a body heater
20 730 and a die retainer heater 740.

In certain embodiments, the respective volumes of cross-head 418 that contain the material(s) that form layers 20, 22 and 24 can be relatively small. For each layer, the volume of cross-head 418 that contains the corresponding material(s) includes a thin portion between the corresponding flow dividers (volume 606 for layer 20, volume
25 604 for layer 22, and volume 602 for layer 24). For each layer, the volume of cross-head 418 that contains the material(s) that form the corresponding layer further includes an additional feed channel volume. The volume in cross-head 418 for the material of layer 22 includes a feed channel volume 605. (The corresponding feed channel volumes for layers 20 and 24 are not visible in the cross-section in Fig. 6).

30 Appropriately designed extrusion apparatuses are available from, for example, Guil Tool and Engineering (West Warwick, RI).

As an example, the volume of cross-head 418 that contains the material(s) from layer 20 is formed is at least about three cubic centimeters (e.g., at least about 3.2 cubic

centimeters, at least about 3.4 cubic centimeters) and/or less than about five cubic centimeters (e.g., less than about 4.5 cubic centimeters, less than about four cubic centimeters). As another example, the of cross-head 418 that contains the material(s) from layer 22 is formed is at least about two cubic centimeters (e.g., at least about 2.2 cubic centimeters, at least about 2.4 cubic centimeters) and/or less than about four cubic centimeters (e.g., less than about 3.5 cubic centimeters, less than about three cubic centimeters). As an additional example, the volume of cross-head 418 that contains the material(s) from layer 24 is formed is at least about three cubic centimeters (e.g., at least about 3.3 cubic centimeters, at least about 3.6 cubic centimeters) and/or less than about 4.5 cubic centimeters (e.g., less than about 4.4 cubic centimeters, less than about 4.3 cubic centimeters).

Typically, extruders 412, 414 and 416 are pre-heated to a desired temperature. For example, extruder 412 may be pre-heated to a temperature of at least about 230°C and/or less than about 315°C (e.g., from about 260°C to about 300°C, from about 275°C to about 290°C), extruder 414 may be pre-heated to a temperature of at least about 175°C and/or less than about 230°C (e.g., from about 190°C to about 210°C, about 200°C), and/or extruder 416 may be pre-heated to a temperature of at least about 190°C and/or less than about 245°C (e.g., from about 200°C to about 225°C, about 200°C). In certain embodiments, extruders 412, 414 and 416 are used to extrude layers 20, 22 and 24, respectively, using these temperatures.

The pressure applied to the melted material(s) in extruders 412, 414 and 416 can be varied as desired. As an example, the pressure applied to the melted material(s) in extruder 412 can be at least about 500 psi (e.g., at least about 1,000 psi, at least about 1,500 psi) and/or less than about 4,000 psi (e.g., less than about 3,000 psi, less than about 2,500 psi), the pressure applied to the melted material(s) in extruder 414 can be at least about 300 psi (e.g., at least about 400 psi, at least about 500 psi) and/or less than about 3,000 psi (e.g., less than about 2,000 psi, less than about 1,500 psi), the pressure applied to the melted material(s) in extruder 416 can be at least about 200 psi (e.g., at least about 300 psi, at least about 400 psi) and/or less than about 1,000 psi (e.g., less than about 900 psi, less than about 800 psi). In certain embodiments, extruders 412, 414 and 416 are used to extrude layers 20, 22 and 24, respectively, using these pressures.

Generally, the temperature of bath 460 is less than the temperature of extrusion apparatus 410. In some embodiments, the temperature of bath 460 is less than about 25°C (e.g., less than about 15°C, less than about 10°C). As an example, bath 460 can be at a temperature of from about 5°C to about 10°C (from about 6°C to about 8°C),
5 such as about 7°C.

In general, the rate at which the tube is drawn through bath 460 can be varied as desired. In certain embodiments, the rate is at least about five feet per minute (e.g., at least about 10 feet per minute, at least about 20 feet per minute, at least about 30 feet per minute) and/or less than about 100 feet per minute (e.g., less than 90 feet per
10 minute, less than about 80 feet per minute, less than about 70 feet per minute, less than about 60 feet per minute, less than about 50 feet per minute). For example, the rate can be from about 20 feet per minute to about 100 feet per minute (e.g., from about 30 feet per minute to about 50 feet per minute), such as about 30 feet per minute.

Steps 320, 330 and 340 can be performed using standard processes, such as
15 disclosed, for example, in U.S. Patent Nos. 5,195,969; 5,270,086 and 5,769,817, which are hereby incorporated by reference. As an example, during step 330 (which can occur before, during or after step 320), a temperature of at least about 120°C and/or less than about 125°C (e.g., about 123.5°C) can be used for at least about three minutes and/or less than about five minutes (e.g., about four minutes). As another example,
20 during step 340, the pressure may be at least about 200 psi to about and/or less than about 300 psi (e.g., from about 245 psi to about 265 psi), and the temperature may be at least about 90°C and less than about 100°C (e.g., from about 90°C to about 95°C).

Without wishing to be bound by theory, it is believed that optional mold heat set
25 step 350 can assist in reducing (e.g., substantially eliminating) the presence of delamination in balloon 14.

The pressure used in step 350 is typically at least about 50 psi (e.g., at least about 100 psi, at least about 200 psi, at least about 225 psi) and/or less than about 400 psi (e.g., less than about 300 psi, less than about 275 psi), such as about 250 psi. The temperature of the balloon in step 350 is usually at least about 50°C (e.g., at least about
30 150°C, at least about 125°C, at least about 140°C) and/or less than about 250°C (e.g., less than about 225°C, less than about 200 °C, less than about 175°C, less than about 160°C), such as from about 145°C to about 150°C. The pressure and temperature are used for at least about five seconds (e.g., at least about 10 seconds, at least about 20

seconds) and/or at most about 50 seconds (e.g., at most about 40 seconds), such as about 30 seconds.

The following examples are illustrative only and not intended as limiting.

In the examples, the burst pressure of a balloon was determined as follows. The
5 balloon was deflated and submerged in a water bath at 37°C. The balloon was then inflated with water at a rate of about 20 psi per second until the balloon burst. The rated burst pressure corresponds to the average pressure at which a balloon burst based on a given population of balloons (e.g., a population of about 30 balloons).

In the examples, the multiple inflation test of a balloon was performed as
10 follows. The balloon was deflated and submerged in a water bath at 37°C. The balloon was inflated to the rated burst pressure of the balloon over the course of about 10 seconds, held at the rated burst pressure for about 30 seconds, and then deflated to a vacuum. A balloon was considered to have passed the multiple inflation test if the inflate/hold/deflate procedure was repeated 40 times with substantially no delamination
15 or defect formation as determined by inspection with a microscope (10X magnification).

Example 1

A three-layer balloon was prepared as follows.

A tube having layers formed of Melinar 5922C (E. I. DuPont de Nemours),
20 Bynel CXA E-418 (E. I. DuPont de Nemours), and PEBAX 6333 (Atofina), respectively, was formed using an extrusion apparatus. The volumes of the portion of the cross-head containing the material was 3.7 cubic centimeters, 2.7 cubic centimeters, and 3.9 cubic centimeters, respectively. The temperatures of the extruders were 550°F, 390°F, and 350°F, respectively. The pressures of the extruders were 2180-2240 psi,
25 1545-1550 psi, and 890-940 psi, respectively. The cooling bath temperature was 45°F, and the line speed was 90 feet per minute. The tube had an inner diameter of 0.0146 inch and an outer diameter of 0.0377 inch.

The tube was formed into a balloon using a balloon formation temperature of 95°C and a balloon pressure of 140 psi. No heat set was used.

30 The balloon had a diameter of 3.0 millimeters, and a length of 20 millimeters. The overall single wall thickness of the balloon was 0.0007 inch. The balloon had a burst pressure of 374 psi (no observed delamination), and a compliance of 3.4%.

Compliance was measured as follows. The balloon was held at 37°C and inflated first to one atmosphere pressure, and then in increments of one atmosphere pressure while measuring the diameter of the balloon. This was done until the balloon reaches the rated burst pressure or until the balloon bursted. A plot of the results was generated, and the slope from four atmospheres pressure to the rated burst pressure was calculated, and was the compliance value (diameter versus pressure).

Example 2

A three-layer balloon was prepared as follows.

A tube having layers formed of Melinar 5922C (E. I. DuPont de Nemours), Blox (Grade XU19080.01, Dow Chemical Company), and Vestamid L210F (Daicel-Degussa Ltd.), respectively, was formed using an extrusion apparatus. The volumes of the portion of the cross-head containing the material was 3.7 cubic centimeters, 2.7 cubic centimeters, and 3.9 cubic centimeters, respectively. The temperatures of the extruders were 610°F, 350°F, and 495°F, respectively. The pressures of the extruders were 4610-4800 psi, 1052-1187 psi, and 2850-2980 psi, respectively. The cooling bath temperature was 45°F, and the line speed was 60 feet per minute. The tube had an inner diameter of 0.027 inch and an outer diameter of 0.063 inch.

The tube was formed into a balloon using a balloon formation temperature of 93°C and a balloon pressure of 340 psi. The heat set temperature was 170°C. The heat set pressure was 200 psi, and the heat set duration was 30 seconds.

The balloon had a diameter of 5.0 millimeters, and a length of 40 millimeters. The overall single wall thickness of the balloon was 0.0011 inch. The balloon had a burst pressure of 377 psi (no observed delamination), a compliance of 3.2% (measured as described in Example 1), and a maximum puncture force of 4.2 pounds.

Example 3

A three-layer balloon was prepared as follows.

A tube having layers formed of Melinar 5922C (E. I. DuPont de Nemours), Bynel CXA E-418 (E. I. DuPont de Nemours), and PEBAX 7033 (Atofina), respectively, was formed using an extrusion apparatus. The volumes of the portion of the cross-head containing the material was 3.7 cubic centimeters, 2.7 cubic centimeters, and 3.9 cubic centimeters, respectively. The temperatures of the extruders were 550°F, 390°F, and 400°F, respectively. The pressures of the extruders were 3020-3090 psi, 1110-1115 psi, and 970-1010 psi, respectively. The cooling bath temperature was

45°F, and the line speed was 30 feet per minute. The tube had an inner diameter of 0.039 inch and an outer diameter of 0.075 inch.

The tube was formed into a balloon using a balloon formation temperature of 95°C and a balloon pressure of 255 psi. The heat set temperature was 170°C. The heat set pressure was 250 psi, and the heat set duration was 30 seconds.

The balloon had a diameter of 7.0 millimeters, and a length of 40 millimeters. The overall single wall thickness of the balloon was 0.0012 inch. The balloon had a burst pressure of 311 psi (no observed delamination), and a compliance of 3.5% (measured as described in Example 1).

10 Example 4

A three-layer balloon was prepared as follows.

A tube having layers formed of Melinar 5922C (E. I. DuPont de Nemours), Bynel CXA E-418 (E. I. DuPont de Nemours), and PEBAX 7233 (Atofina), respectively, was formed using an extrusion apparatus. The volumes of the portion of the cross-head containing the material was 3.7 cubic centimeters, 2.7 cubic centimeters, and 3.9 cubic centimeters, respectively. The temperatures of the extruders were 550°F, 390°F, and 400°F, respectively. The pressures of the extruders were 2970-3080 psi, 1330-1350 psi, and 790-840 psi, respectively. The cooling bath temperature was 45°F, and the line speed was 30 feet per minute.

20 The tube was formed into a balloon using a balloon formation temperature of 92°C and a balloon pressure of 280 psi. The heat set temperature was 170°C. The heat set pressure was 200 psi, and the heat set duration was 30 seconds.

The balloon had a diameter of 7.0 millimeters, and a length of 20 millimeters. The overall single wall thickness of the balloon was 0.0012 inch. The balloon had a burst pressure of 296 psi. The balloon was exposed to the multiple inflation test and showed no signs of delamination (10X magnification) after bursting.

Nine balloons were prepared according to the same method. Each balloon was exposed to the multiple inflation test and showed no signs of delamination (10X magnification) after bursting.

30 Example 5

A three-layer balloon was prepared as follows.

A tube having layers formed of Melinar 5922C (E. I. DuPont de Nemours), Bynel CXA E-418 (E. I. DuPont de Nemours), and Vestamid L2101F (Atofina),

respectively, was formed using an extrusion apparatus. The volumes of the portion of the cross-head containing the material was 3.7 cubic centimeters, 2.7 cubic centimeters, and 3.9 cubic centimeters, respectively. The temperatures of the extruders were 565°F, 300°F, and 350°F, respectively. The pressures of the extruders were 4020-4040 psi, 5 3130-3160 psi, and 2820-2900 psi, respectively. The cooling bath temperature was 45°F, and the line speed was 65 feet per minute.

The tube was formed into a balloon using a balloon formation temperature of 93°C and a balloon pressure of 370 psi. The heat set temperature was 170°C. The heat set pressure was 270 psi, and the heat set duration was 30 seconds.

10 The balloon had a diameter of 5.0 millimeters, and a length of 40 millimeters. The overall single wall thickness of the balloon was 0.0013 inch. The balloon had a burst pressure of 406 psi. The balloon was exposed to the multiple inflation test and showed no signs of delamination (10X magnification) after bursting.

15 19 balloons were prepared according to the same method. Each balloon was exposed to the multiple inflation test and showed no signs of delamination (10X magnification) after bursting.

Example 6

A three-layer balloon was prepared as follows.

A tube having layers formed of Melinar 5922C (E. I. DuPont de Nemours), 20 Blox (Grade XU19080.01, Dow Chemical Company), and Vestamid L2101F (Atofina), respectively, was formed using an extrusion apparatus. The volumes of the portion of the cross-head containing the material was 3.7 cubic centimeters, 2.7 cubic centimeters, and 3.9 cubic centimeters, respectively. The temperatures of the extruders were 540°F, 350°F, and 350°F, respectively. The pressures of the extruders were 6020-6210 psi, 25 3860-3870 psi, and 4070-5220 psi, respectively. The cooling bath temperature was 45°F, and the line speed was 70 feet per minute.

The tube was formed into a balloon using a balloon formation temperature of 93°C and a balloon pressure of 360 psi. The heat set temperature was 170°C. The heat set pressure was 200 psi, and the heat set duration was 60 seconds.

30 The balloon had a diameter of 5.0 millimeters, and a length of 40 millimeters. The overall single wall thickness of the balloon was 0.0013 inch. The balloon had a burst pressure of 405 psi. The balloon was exposed to the multiple inflation test and showed no signs of delamination (10X magnification) after bursting.

Nine balloons were prepared according to the same method. Each balloon was exposed to the multiple inflation test and showed no signs of delamination (10X magnification) after bursting.

Example 7

5 A three-layer balloon was prepared as follows.

A tube having layers formed of Melinar 5922C (E. I. DuPont de Nemours), Bynel CXA E-418 (E. I. DuPont de Nemours), and PEBAX 7233 (Atofina), respectively, was formed using an extrusion apparatus. The volumes of the portion of the cross-head containing the material was 3.7 cubic centimeters, 2.7 cubic centimeters, 10 and 3.9 cubic centimeters, respectively. The temperatures of the extruders were 550°F, 390°F, and 400°F, respectively. The pressures of the extruders were 2610-2700 psi, 1210-1225 psi, and 790-840 psi, respectively. The cooling bath temperature was 45°F, and the line speed was 34 feet per minute.

The tube was formed into a balloon using a balloon formation temperature of 15 93°C and a balloon pressure of 265 psi. The heat set temperature was 170°C. The heat set pressure was 250 psi, and the heat set duration was 30 seconds.

The balloon had a diameter of 7.0 millimeters, and a length of 40 millimeters. The overall single wall thickness of the balloon was 0.0023 inch. The balloon had a burst pressure of 265 psi. The balloon was exposed to the multiple inflation test and 20 showed no signs of delamination (10X magnification) after bursting.

Nine balloons were prepared according to the same method. Each balloon was exposed to the multiple inflation test and showed no signs of delamination (10X magnification) after bursting.

Example 8

25 A three-layer balloon was prepared as follows.

A tube having layers formed of Melinar 5922C (E. I. DuPont de Nemours), Bynel CXA E-418 (E. I. DuPont de Nemours), and Vestamid L2101F (Atofina), respectively, was formed using an extrusion apparatus. The volumes of the portion of the cross-head containing the material was 3.7 cubic centimeters, 2.7 cubic centimeters, 30 and 3.9 cubic centimeters, respectively. The temperatures of the extruders were 550°F, 350°F, and 520°F, respectively. The pressures of the extruders were 5600-5840 psi, 3350-3384 psi, and 3910-3990 psi, respectively. The cooling bath temperature was 45°F, and the line speed was 50 feet per minute.

The tube was formed into a balloon using a balloon formation temperature of 93°C and a balloon pressure of 380 psi. The heat set temperature was 180°C. The heat set pressure was 300 psi, and the heat set duration was 30 seconds.

The balloon had a diameter of 5.0 millimeters, and a length of 40 millimeters.
5 The overall single wall thickness of the balloon was 0.0013 inch. The balloon had a burst pressure of 459 psi. The balloon was exposed to the multiple inflation test and showed no signs of delamination (10X magnification) after bursting.

Nine balloons were prepared according to the same method. Each balloon was exposed to the multiple inflation test and showed no signs of delamination (10X
10 magnification) after bursting.

Example 9

A three-layer balloon was prepared as follows.

A tube having layers formed of Melinar 5922C (E. I. DuPont de Nemours), Bynel CXA E-418 (E. I. DuPont de Nemours), and Vestamid L2101F (Atofina),
15 respectively, was formed using an extrusion apparatus. The volumes of the portion of the cross-head containing the material was 3.7 cubic centimeters, 2.7 cubic centimeters, and 3.9 cubic centimeters, respectively. The temperatures of the extruders were 565°F, 250°F, and 520°F, respectively. The pressures of the extruders were 4220-4240 psi, 2000-2020 psi, and 2200-2280 psi, respectively. The cooling bath temperature was
20 45°F, and the line speed was 45 feet per minute.

The tube was formed into a balloon using a balloon formation temperature of 93°C and a balloon pressure of 305 psi. The heat set temperature was 170°C. The heat set pressure was 200 psi, and the heat set duration was 30 seconds.

The balloon had a diameter of 8.0 millimeters, and a length of 40 millimeters.
25 The overall single wall thickness of the balloon was 0.0013 inch. The balloon had a burst pressure of 316 psi. The balloon was exposed to the multiple inflation test and showed no signs of delamination (10X magnification) after bursting.

Nine balloons were prepared according to the same method. Each balloon was exposed to the multiple inflation test and showed no signs of delamination (10X
30 magnification) after bursting.

While certain embodiments have been described, the invention is not limited to these embodiments.

As an example, the wall of the balloon can include additional layers so that the total number of layers in the wall exceeds three (e.g., at least four layers, at least five layers, at least six layers, at least seven layers, at least eight layers, at least nine layers, at least 10 layers, at least 15 layers, at least 20 layers, at least 30 layers, at least 40 layers, at least 50 layers).

As another example, layers 20, 22 and 24 need not be coextensive along their entire length. For example, there may be one or more interruptions (e.g., points of noncontact) between layers 20, 22 and/or 24.

In embodiments, a multilayer wall as described above can be attached to the surface of another, separately formed tube (e.g., by adhesive) which may be used in a medical device (e.g., a catheter body) or further processed (e.g., to form a balloon).

Furthermore, the balloons can be used in various medical procedures. As an example, the balloons can be used to open an occluded lumen, as in angioplasty. As another example, the balloons can be used to position another medical implement, such as a stent or graft, within a lumen. As an additional example, the balloons can be used to selectively block a passageway. In additional examples, the balloons can be used in various combinations of these procedures.

In addition, the methods can be used to form medical devices other than a balloon, such as a catheter shaft.

Other embodiments are in the claims.

Claims

1. A medical device having a wall that comprises:
a first layer including a first layer material selected from the group consisting of polyesters and polyester copolymers;
5 a second layer including a second layer material selected from the group consisting of polyamides and polyamide copolymers; and
a third layer including an adhesive material,
wherein the first, second and third layers are coextruded.
- 10 2. The medical device of claim 1, wherein the third layer is between the first and second layers.
3. The medical device of claim 1, wherein the first layer is disposed along a first surface of the third layer, and the second layer is disposed along a second surface of the
15 second layer.
4. The medical device of claim 1, wherein a thickness of the first layer is at least about 50 percent of a total thickness of the wall.
- 20 5. The medical device of claim 1, wherein a thickness of the second layer is less than about 20 percent of a total thickness of the wall.
6. The medical device of claim 1, wherein the adhesive material comprises an adhesive polymer.
25
7. The medical device of claim 6, wherein the adhesive polymer comprises an ethylene vinyl acetate polymer.
8. The medical device of claim 1, wherein the third layer has a thickness of less
30 than about 0.005 inch.
9. The medical device of claim 1, wherein the medical device comprises a device selected from the group consisting of balloons, tubes and catheter shafts.

10. The medical device of claim 1, wherein the medical device comprises a balloon.
11. The medical device of claim 10, wherein the balloon has a diameter of at least
5 about one millimeter.
12. The medical device of claim 1, wherein the first layer material and the second layer material are biaxially oriented.
- 10 13. The medical device of claim 1, wherein the wall further includes additional layers of an adhesive material and additional layers comprising materials selected from the group consisting of polyesters, polyester copolymers, polyamides and polyamide copolymers,
wherein the layers in the wall are coextruded, and alternating layers of the wall
15 comprise adhesive material.
14. A medical device having a wall that comprises:
a first layer including a first layer material selected from the group consisting of polyesters and polyester copolymers;
20 a second layer including a second layer material selected from the group consisting of polyamides and polyamide copolymers; and
a third layer including an adhesive material,
wherein at thickness of the first layer is at least about 50 percent of a total
thickness of the wall.
25
15. The medical device of claim 14, wherein the thickness of the first layer is at least about 60 percent of the total thickness of the wall.
16. The medical device of claim 14, wherein the thickness of the first layer is at
30 least about 70 percent of the total thickness of the wall.
17. The medical device of claim 14, wherein the third layer is between the first and second layers.

18. The medical device of claim 14, wherein the first layer is disposed along a first surface of the third layer, and the second layer is disposed along a second surface of the second layer.
- 5
19. The medical device of claim 14, wherein at thickness of the second layer is less than about 20 percent of the total thickness of the wall.
20. The medical device of claim 14, wherein the adhesive material comprises an
10 adhesive polymer.
21. The medical device of claim 20, wherein the adhesive polymer comprises an ethylene vinyl acetate polymer.
- 15 22. The medical device of claim 14, wherein the third layer a thickness of less than about 0.005 inch.
23. The medical device of claim 14, wherein the medical device comprises a device selected from the group consisting of balloons, tubes and catheter shafts.
- 20
24. The medical device of claim 14, wherein the medical device comprises a balloon.
25. The medical device of claim 24, wherein the balloon has a diameter of at least
25 about one millimeter.
26. The medical device of claim 14, wherein the first layer material and the second layer material are biaxially oriented.
- 30 27. The medical device of claim 14, wherein the wall further includes additional layers of an adhesive material and additional layers comprising materials selected from the group consisting of polyesters, polyester copolymers, polyamides and polyamide copolymers,

wherein the layers in the wall are coextruded, and alternating layers of the wall comprise adhesive material.

28. A medical device having a wall that comprises:
- 5 a first layer including a first layer material selected from the group consisting of polyesters and polyester copolymers;
- a second layer including a second layer material selected from the group consisting of polyamides and polyamide copolymers; and
- a third layer including an adhesive material,
- 10 wherein at thickness of the third layer is less than about 20 percent of a total thickness of the wall.
29. The medical device of claim 28, wherein the thickness of the third layer is less than about 10 percent of the total thickness of the wall.
- 15
30. The medical device of claim 28, wherein the thickness of the third layer is less than about five percent of the total thickness of the wall.
31. The medical device of claim 28, wherein the third layer is between the first and
- 20 second layers.
32. The medical device of claim 28, wherein the first layer is disposed along a first surface of the third layer, and the second layer is disposed along a second surface of the second layer.
- 25
33. The medical device of claim 28, wherein the adhesive material comprises an adhesive polymer.
34. The medical device of claim 33, wherein the adhesive polymer comprises an
- 30 ethylene vinyl acetate polymer.
35. The medical device of claim 28, wherein the third layer has a thickness of less than about 0.005 inch.

36. The medical device of claim 28, wherein the medical device comprises a device selected from the group consisting of balloons, tubes and catheter shafts.
- 5 37. The medical device of claim 28, wherein the medical device comprises a balloon.
38. The medical device of claim 37, wherein the balloon has a diameter of at least about one millimeter.
- 10 39. The medical device of claim 28, wherein the first layer material and the second layer material are biaxially oriented.
40. The medical device of claim 28, wherein the wall further includes additional
15 layers of an adhesive material and additional layers comprising materials selected from the group consisting of polyesters, polyester copolymers, polyamides and polyamide copolymers,
wherein the layers in the wall are coextruded, and alternating layers of the wall comprise adhesive material.
- 20 41. A medical device having a wall that comprises:
a first layer including a first layer material selected from the group consisting of polyesters and polyester copolymers;
a second layer including a second layer material selected from the group
25 consisting of polyamides and polyamide copolymers; and
a third layer including an adhesive material,
wherein the third layer is less than about 0.005 inch thick.
42. The medical device of claim 41, wherein the third layer is less than about 0.004
30 inch thick.
43. The medical device of claim 41, wherein the third layer is less than about 0.003 inch thick.

44. The medical device of claim 41, wherein the third layer is between the first and second layers.
- 5 45. The medical device of claim 41, wherein the first layer is disposed along a first surface of the third layer, and the second layer is disposed along a second surface of the second layer.
- 10 46. The medical device of claim 41, wherein the adhesive material comprises an adhesive polymer.
47. The medical device of claim 41, wherein the adhesive polymer comprises an ethylene vinyl acetate polymer.
- 15 48. The medical device of claim 41, wherein the medical device comprises a device selected from the group consisting of balloons, tubes and catheter shafts.
49. The medical device of claim 41, wherein the medical device comprises a balloon.
- 20 50. The medical device of claim 49, wherein the balloon has a diameter of at least about one millimeter.
51. The medical device of claim 41, wherein the first layer material and the second layer material are biaxially oriented.
- 25 52. The medical device of claim 41, wherein the wall further includes additional layers of an adhesive material and additional layers comprising materials selected from the group consisting of polyesters, polyester copolymers, polyamides and polyamide copolymers,
- 30 wherein the layers in the wall are coextruded, and alternating layers of the wall comprise adhesive material.

53. A method of forming a tube, the method comprising:
coextruding first, second and third materials to form a wall of the tube with first, second and third layers, the first layer including a first layer material selected from the group consisting of polyesters and polyester copolymers, the second layer including a second layer material selected from the group consisting of polyamides and polyamide copolymers, the third layer including an adhesive material; and
5 wherein the first layer comprises a polyester, the second layer comprises a polyamide and the third layer comprises an adhesive.
- 10 54. The method of claim 53, wherein the first layer material is heated to a temperature of from about 230°C to about 315°C during coextrusion.
55. The method of claim 53, wherein the second layer material is heated to a temperature of from about 190°C to about 245°C during coextrusion.
- 15 56. The method of claim 53, wherein the adhesive is heated to a temperature of from about 175°C to about 230°C during coextrusion.
57. The method of claim 53, wherein a pressure of at least about 500 pounds per square inch is applied to the first layer material during coextrusion.
- 20 58. The method of claim 53, wherein a pressure of at least about 250 pounds per square inch is applied to the second layer during extrusion.
- 25 59. The method of claim 53, wherein a pressure of at about 250 pounds per square inch is applied to the adhesive during extrusion.
60. The method of claim 53, wherein the method further includes drawing the coextruded tube.
- 30 61. The method of claim 63, wherein the coextruded tube is drawn at a rate of at least about 10 feet per minute.

62. The method of claim 63, further comprising passing the drawn tube through a bath having a temperature of less than about 25°C.
63. The method of claim 62, further comprising forming the coextruded tube into a
5 medical device.
64. The method of claim 63, wherein the medical device comprises a balloon.
65. The method of claim 63, further comprising heating the medical device to a
10 temperature of at least about 50°C.
66. The method of claim 65, wherein the medical device is heated for at least about
10 seconds.
- 15 67. The method of claim 65, wherein the medical device is exposed to a pressure of
at least about 100 pounds per square inch while being heated.
68. A method of forming a tube, the method comprising:
coextruding multiple polymer layers to form a wall of the tube;
20 forming the tube into a balloon; and
heating the balloon to a temperature of at least about 50°C at a pressure of at
least about 50 pounds per square inch.
69. The method of claim 68, wherein the balloon is heated to a temperature of at
25 least about 100°C.
70. The method of claim 68, wherein the balloon is heated to a temperature of at
least about 200°C.
- 30 71. The method of claim 68, wherein the balloon is exposed to a pressure of at least
about 100 pounds per square inch while being heated.

72. The method of claim 68, wherein the balloon is exposed to a pressure of at least about 200 pounds per square inch while being heated.
73. The method of claim 68, wherein the balloon is heated for at least about 10
5 seconds.
74. A balloon having a wall that comprises:
a first layer including a first layer material selected from the group consisting of polyesters and polyester copolymers;
10 a second layer including a second layer material selected from the group consisting of polyamides and polyamide copolymers; and
a third layer including an adhesive material,
wherein the balloon has a diameter of more than about four millimeters, the balloon has a burst pressure of more than about 200 psi, the balloon has a compliance
15 of more than about two percent, and the first, second and third layers are coextruded.
75. The balloon of claim 74, wherein the burst pressure more than about 225 psi.
76. The balloon of claim 74, wherein the burst pressure is more than about 250 psi
20
77. The balloon of claim 74, wherein the compliance is more than about 2.25%.
78. The balloon of claim 74, wherein the compliance is more than about 2.5%.
- 25 79. The balloon of claim 74, wherein the diameter is more than about 4.25 millimeters.
80. The balloon of claim 74, wherein the diameter is more than about 4.5
30 millimeters.

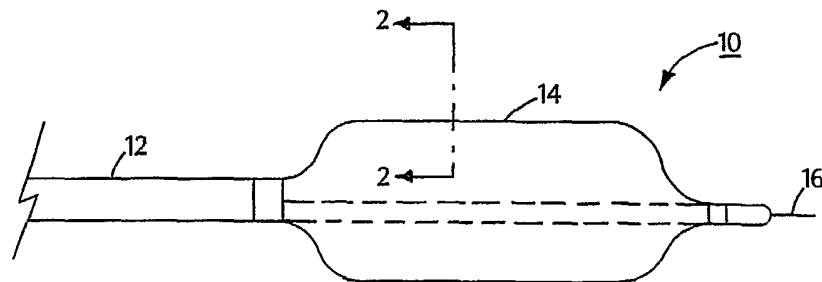

FIG. 1

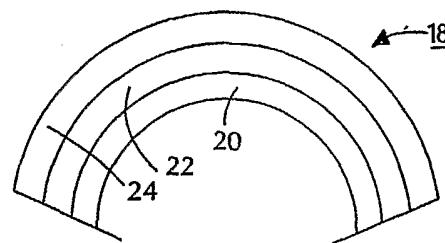
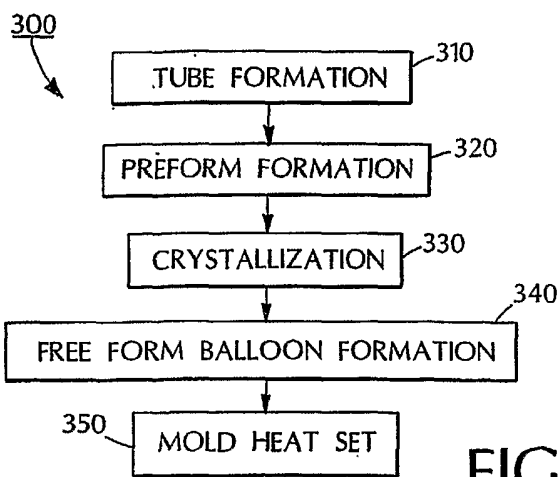

FIG. 2

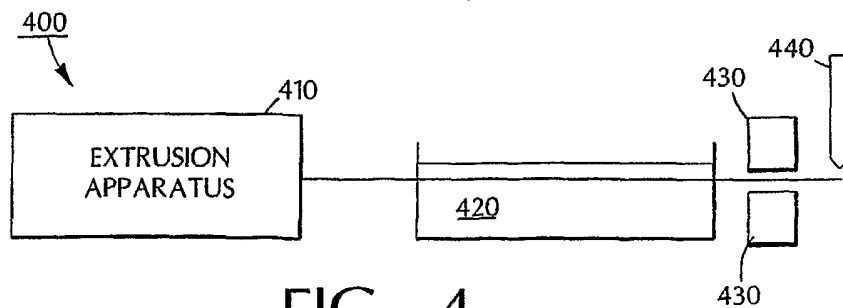

FIG. 4

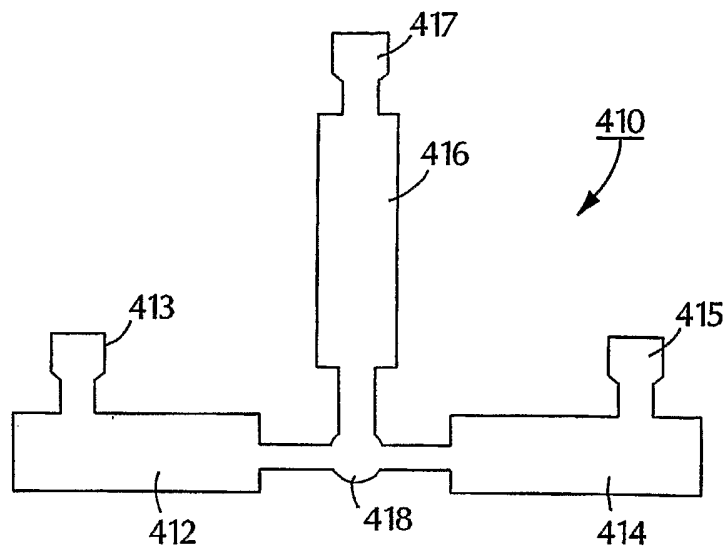

FIG. 5

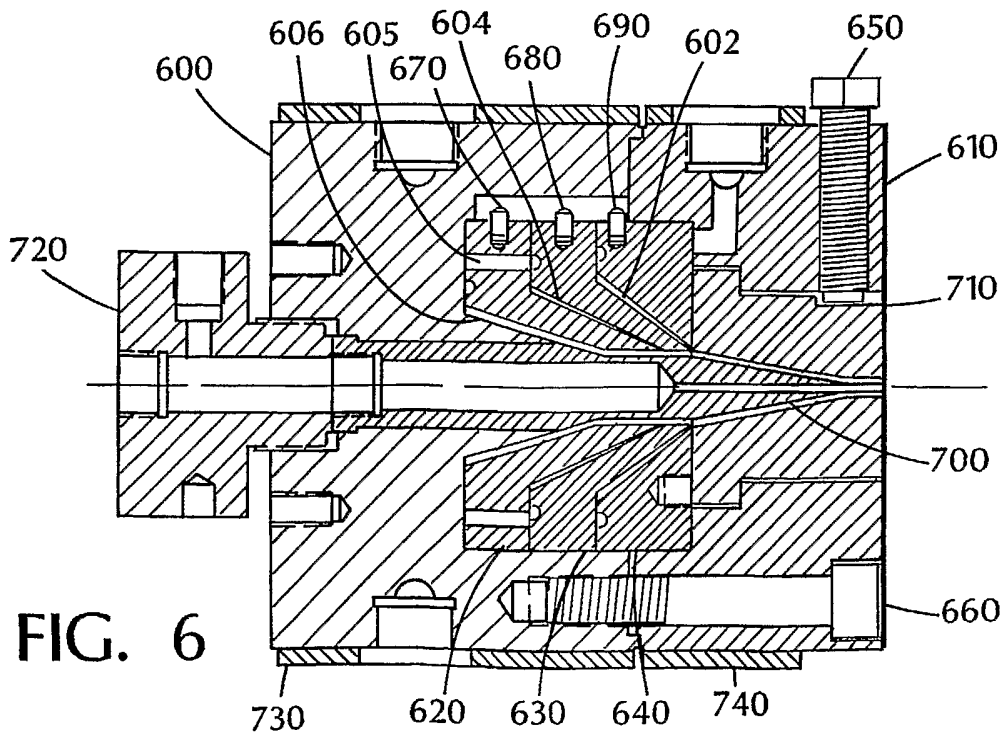

FIG. 6

INTERNATIONAL SEARCH REPORT

A. CLASSIFICATION OF SUBJECT MATTER
 IPC 7 A61L29/12 A61L31/12 B32B7/10

According to International Patent Classification (IPC) or to both national classification and IPC

B. FIELDS SEARCHED
 Minimum documentation searched (classification system followed by classification symbols)
 IPC 7 A61L B32B

Documentation searched other than minimum documentation to the extent that such documents are included in the fields searched

Electronic data base consulted during the international search (name of data base and, where practical, search terms used)
 EPO-Internal, WPI Data, PAJ, EMBASE, BIOSIS, MEDLINE, COMPENDEX

C. DOCUMENTS CONSIDERED TO BE RELEVANT

Category *	Citation of document, with indication, where appropriate, of the relevant passages	Relevant to claim No.
X	US 6 136 258 A (PEDERSON SR BRIAN A ET AL) 24 October 2000 (2000-10-24) column 5, line 60 - column 6, line 20	68-73
Y	column 2, line 40 - line 49	1-67, 74-80
Y	US 6 136 394 A (KARSTEN PETRUS J A) 24 October 2000 (2000-10-24) column 1, line 44 - column 2, line 16 column 2, line 53 - line 67 column 3, line 1 - line 5	1-67, 74-80
Y	EP 0 803 264 A (SCHNEIDER EUROP AG) 29 October 1997 (1997-10-29) column 2, line 50 - column 3, line 20 column 4, line 15 - line 36	1-67, 74-80
	-/--	

Further documents are listed in the continuation of box C. Patent family members are listed in annex.

* Special categories of cited documents :

A document defining the general state of the art which is not considered to be of particular relevance

E earlier document but published on or after the international filing date

L document which may throw doubts on priority claim(s) or which is cited to establish the publication date of another citation or other special reason (as specified)

O document referring to an oral disclosure, use, exhibition or other means

P document published prior to the international filing date but later than the priority date claimed

T later document published after the international filing date or priority date and not in conflict with the application but cited to understand the principle or theory underlying the invention

X document of particular relevance; the claimed invention cannot be considered novel or cannot be considered to involve an inventive step when the document is taken alone

Y document of particular relevance; the claimed invention cannot be considered to involve an inventive step when the document is combined with one or more other such documents, such combination being obvious to a person skilled in the art.

* & * document member of the same patent family

Date of the actual completion of the international search 16 October 2003	Date of mailing of the international search report 03/11/2003
---	---

Name and mailing address of the ISA European Patent Office, P.B. 5818 Patentlaan 2 NL - 2280 HV Rijswijk Tel. (+31-70) 340-2040, Tx. 31 651 epo nl, Fax: (+31-70) 340-3016	Authorized officer Bochelen, D
--	--

INTERNATIONAL SEARCH REPORT

Internati	Application No
PCT/US	03/20861

C.(Continuation) DOCUMENTS CONSIDERED TO BE RELEVANT

Category °	Citation of document, with indication, where appropriate, of the relevant passages	Relevant to claim No.
Y	US 5 356 709 A (LO YING-CHENG ET AL) 18 October 1994 (1994-10-18) column 1, line 58 -column 2, line 39; claim 1 -----	1-67, 74-80
Y	US 5 270 086 A (HAMLIN ROBERT N) 14 December 1993 (1993-12-14) column 5, line 61 -column 6, line 4; figure 6 -----	1-67, 74-80
A	US 6 335 101 B1 (BAUMANN FRANZ-ERICH ET AL) 1 January 2002 (2002-01-01) the whole document -----	1-80

INTERNATIONAL SEARCH REPORT

ation on patent family members

Internati Application No

PCT/LJ 03/20861

Patent document cited in search report		Publication date	Patent family member(s)	Publication date
US 6136258	A	24-10-2000	US 5195969 A	23-03-1993
			US 6482348 B1	19-11-2002
			CA 2107690 A1	27-10-1992
			DE 69217928 D1	10-04-1997
			DE 69217928 T2	31-07-1997
			DE 69231210 D1	03-08-2000
			DE 69231210 T2	30-11-2000
			EP 0581873 A1	09-02-1994
			EP 0742030 A2	13-11-1996
			EP 0953364 A2	03-11-1999
			JP 3418872 B2	23-06-2003
			JP 6507101 T	11-08-1994
			JP 2003047661 A	18-02-2003
			US 5366442 A	22-11-1994
			WO 9219316 A1	12-11-1992
US 6136394	A	24-10-2000	BE 1010914 A3	02-03-1999
			CA 2226443 A1	11-08-1998
			EP 0858882 A1	19-08-1998
EP 0803264	A	29-10-1997	EP 0803264 A1	29-10-1997
			AT 229356 T	15-12-2002
			AU 705840 B2	03-06-1999
			AU 1645497 A	30-10-1997
			CA 2199333 A1	26-10-1997
			DE 69625329 D1	23-01-2003
			DE 69625329 T2	02-10-2003
			EP 1287845 A2	05-03-2003
			ES 2188687 T3	01-07-2003
			JP 10033684 A	10-02-1998
			US 6319228 B1	20-11-2001
			US 2002022824 A1	21-02-2002
US 5356709	A	18-10-1994	AT 164086 T	15-04-1998
			AU 661781 B2	03-08-1995
			AU 4248693 A	13-12-1993
			BR 9305523 A	18-10-1994
			CA 2112412 A1	12-05-1993
			DE 69317508 D1	23-04-1998
			DE 69317508 T2	05-11-1998
			EP 0597065 A1	18-05-1994
			ES 2116450 T3	16-07-1998
			JP 7507948 T	07-09-1995
			JP 3234927 B2	04-12-2001
			MX 9302802 A1	31-05-1994
			NO 940120 A	13-01-1994
			NZ 252603 A	26-01-1996
			SG 50378 A1	20-07-1998
			WO 9323093 A1	25-11-1993
US 5270086	A	14-12-1993	US 6132824 A	17-10-2000
			AT 91638 T	15-08-1993
			AU 626103 B2	23-07-1992
			AU 6317290 A	28-03-1991
			CA 2025962 A1	26-03-1991
			DE 69002295 D1	26-08-1993
			DE 69002295 T2	04-11-1993
			DK 420488 T3	30-08-1993

INTERNATIONAL SEARCH REPORT

In addition on patent family members

Internation	Application No.
PCT/US J3/20861	

Patent document cited in search report	Publication date	Patent family member(s)	Publication date
US 5270086 A		EP 0420488 A1	03-04-1991
		ES 2043289 T3	16-12-1993
		IE 903431 A1	24-04-1991
		JP 10043287 A	17-02-1998
		JP 3205064 A	06-09-1991
		JP 5075432 B	20-10-1993
		NO 904145 A , B,	26-03-1991
US 6335101 B1 01-01-2002		DE 19908640 A1	31-08-2000
		BR 0000682 A	23-01-2001
		CN 1268432 A , B	04-10-2000
		EP 1031411 A2	30-08-2000
		JP 2000246854 A	12-09-2000