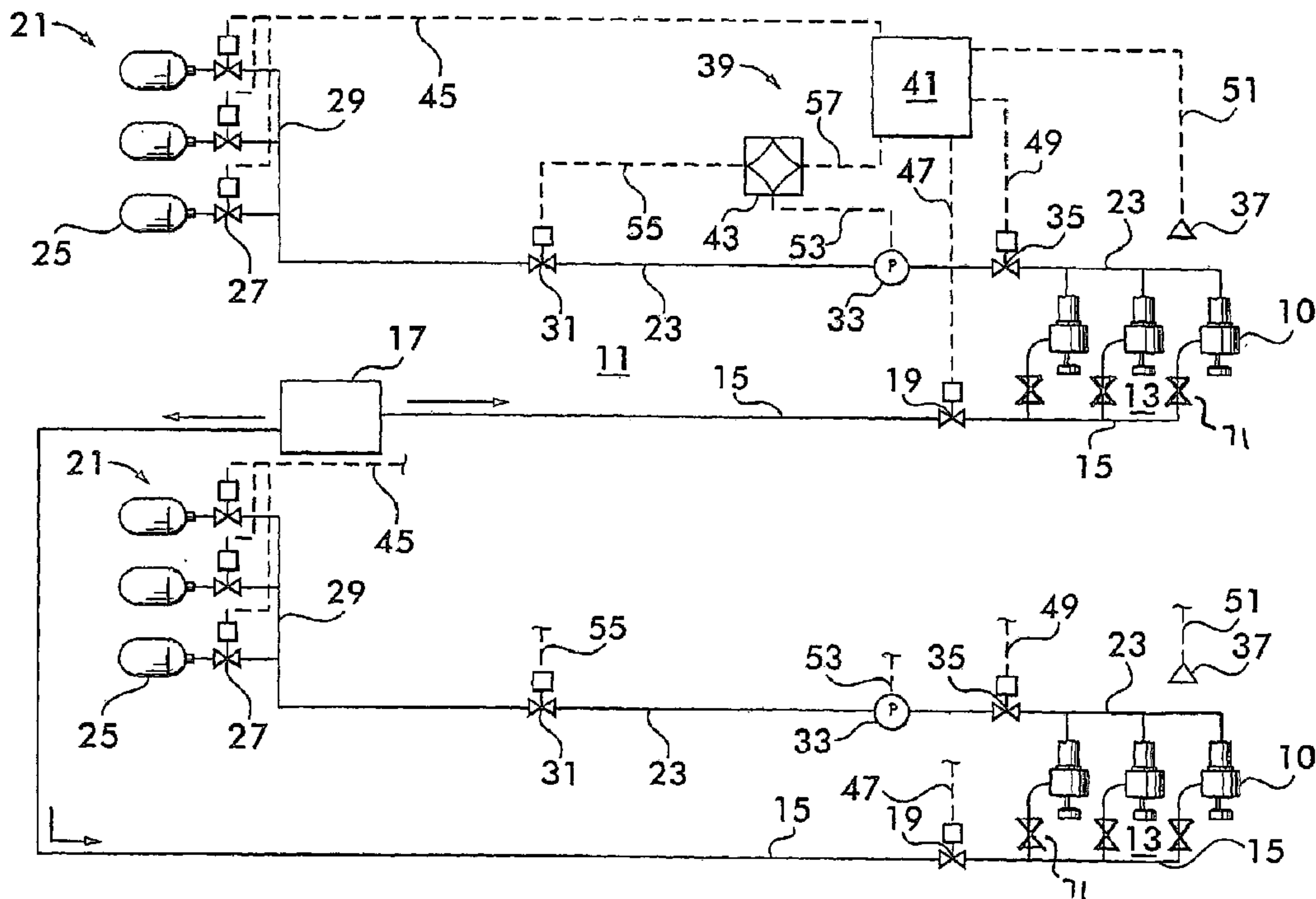




(86) Date de dépôt PCT/PCT Filing Date: 2007/10/31  
 (87) Date publication PCT/PCT Publication Date: 2008/05/15  
 (45) Date de délivrance/Issue Date: 2012/07/10  
 (85) Entrée phase nationale/National Entry: 2009/05/05  
 (86) N° demande PCT/PCT Application No.: US 2007/022873  
 (87) N° publication PCT/PCT Publication No.: 2008/057331  
 (30) Priorité/Priority: 2006/11/06 (US60/864,480)

(51) Cl.Int./Int.Cl. *A62C 35/00* (2006.01),  
*A62C 2/00* (2006.01), *A62C 3/00* (2006.01),  
*A62C 31/07* (2006.01), *A62C 35/11* (2006.01),  
*A62C 35/68* (2006.01), *B05B 1/26* (2006.01)  
 (72) Inventeurs/Inventors:  
 REILLY, WILLIAM J., US;  
 BALLARD, ROBERT J., US;  
 BLEASE, KEVIN J., US;  
 IDE, STEPHEN R., US  
 (73) Propriétaire/Owner:  
 VICTAULIC COMPANY, US  
 (74) Agent: BERESKIN & PARR LLP/S.E.N.C.R.L.,S.R.L.

(54) Titre : SYSTEME DE SUPPRESSION DE FEU A DOUBLE EXTINCTION UTILISANT DES DISTRIBUTEURS BASSE  
 PRESSION A HAUTE VITESSE  
 (54) Title: DUAL EXTINGUISHMENT FIRE SUPPRESSION SYSTEM USING HIGH VELOCITY LOW PRESSURE  
 EMITTERS



(57) Abrégé/Abstract:

A fire suppression system is disclosed. The system includes a gaseous extinguishing agent and a liquid extinguishing agent. At least one emitter is in fluid communication with the liquid and gas. The emitter is used to establish a gas stream, atomize and entrain the liquid into the gas stream and discharge the resulting liquid-gas stream onto the fire. A method of operating the system is also disclosed. The method includes establishing a gas stream having first and second shock fronts using the emitter, atomizing and entraining the liquid with the gas at one of the two shock fronts to form a liquid-gas stream, and discharging the stream onto the fire. The method also includes creating a plurality of shock diamonds in the liquid-gas stream discharged from the emitter.



(12) INTERNATIONAL APPLICATION PUBLISHED UNDER THE PATENT COOPERATION TREATY (PCT)

(19) World Intellectual Property Organization  
International Bureau(43) International Publication Date  
15 May 2008 (15.05.2008)

PCT

(10) International Publication Number  
**WO 2008/057331 A3**

## (51) International Patent Classification:

A62C 35/00 (2006.01) A62C 2/00 (2006.01)  
 A62C 35/11 (2006.01) A62C 3/00 (2006.01)  
 A62C 31/07 (2006.01) B05B 1/26 (2006.01)  
 A62C 35/68 (2006.01)

## (21) International Application Number:

PCT/US2007/022873

(22) International Filing Date: 31 October 2007 (31.10.2007)

(25) Filing Language: English

(26) Publication Language: English

## (30) Priority Data:

60/864,480 6 November 2006 (06.11.2006) US

(71) Applicant (for all designated States except US): **VICTAULIC COMPANY** [US/US]; 4901 Kesslersville Road, Easton, PA 18040 (US).

## (72) Inventors; and

(75) Inventors/Applicants (for US only): **REILLY, William, J.** [US/US]; 209 Hampton Court, Langhorne, PA 19047 (US). **BALLARD, Robert, J.** [US/US]; 4102 Redbud Drive, Whitehall, PA 18052 (US). **BLEASE, Kevin, J.** [US/US]; 141 Parker Avenue, Easton, PA 18042 (US). **IDE, Stephen, R.** [US/US]; 1012 Clearfield Road, Nazareth, PA 18064 (US).

(74) Agent: **CHIONCHIO, John A.**; Synnestvedt & Lechner LLP, Suite 2600, 1101 Market Street, Philadelphia, PA 19107-2950 (US).

(81) Designated States (unless otherwise indicated, for every kind of national protection available): AE, AG, AL, AM, AT, AU, AZ, BA, BB, BG, BH, BR, BW, BY, BZ, CA, CH, CN, CO, CR, CU, CZ, DE, DK, DM, DO, DZ, EC, EE, EG, ES, FI, GB, GD, GE, GH, GM, GT, HN, HR, HU, ID, IL, IN, IS, JP, KE, KG, KM, KN, KP, KR, KZ, LA, LC, LK, LR, LS, LT, LU, LY, MA, MD, ME, MG, MK, MN, MW, MX, MY, MZ, NA, NG, NI, NO, NZ, OM, PG, PH, PL, PT, RO, RS, RU, SC, SD, SE, SG, SK, SL, SM, SV, SY, TJ, TM, TN, TR, TT, TZ, UA, UG, US, UZ, VC, VN, ZA, ZM, ZW.

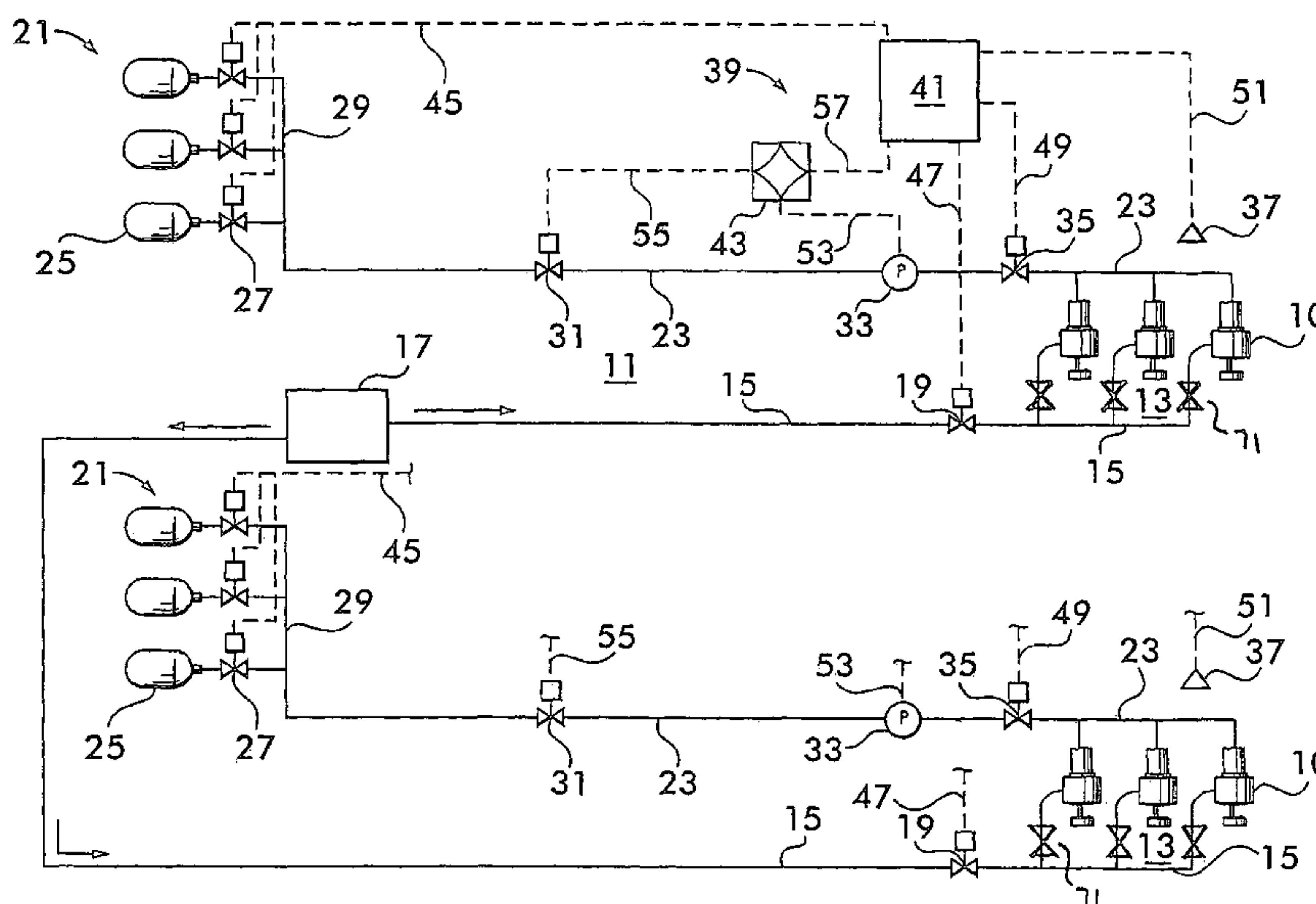
(84) Designated States (unless otherwise indicated, for every kind of regional protection available): ARIPO (BW, GH, GM, KE, LS, MW, MZ, NA, SD, SL, SZ, TZ, UG, ZM, ZW), Eurasian (AM, AZ, BY, KG, KZ, MD, RU, TJ, TM), European (AT, BE, BG, CH, CY, CZ, DE, DK, EE, ES, FI, FR, GB, GR, HU, IE, IS, IT, LT, LU, LV, MC, MT, NL, PL, PT, RO, SE, SI, SK, TR), OAPI (BF, BJ, CF, CG, CI, CM, GA, GN, GQ, GW, ML, MR, NE, SN, TD, TG).

## Declaration under Rule 4.17:

— of inventorship (Rule 4.17(iv))

[Continued on next page]

(54) Title: DUAL EXTINGUISHMENT FIRE SUPPRESSION SYSTEM USING HIGH VELOCITY LOW PRESSURE EMITTERS



(57) Abstract: A fire suppression system is disclosed. The system includes a gaseous extinguishing agent and a liquid extinguishing agent. At least one emitter is in fluid communication with the liquid and gas. The emitter is used to establish a gas stream, atomize and entrain the liquid into the gas stream and discharge the resulting liquid-gas stream onto the fire. A method of operating the system is also disclosed. The method includes establishing a gas stream having first and second shock fronts using the emitter, atomizing and entraining the liquid with the gas at one of the two shock fronts to form a liquid-gas stream, and discharging the stream onto the fire. The method also includes creating a plurality of shock diamonds in the liquid-gas stream discharged from the emitter.

WO 2008/057331 A3

**WO 2008/057331 A3**



**Published:**

— *with international search report*

**(88) Date of publication of the international search report:**  
20 November 2008

**DUAL EXTINGUISHMENT FIRE SUPPRESSION SYSTEM  
USING HIGH VELOCITY LOW PRESSURE EMITTERS**

Cross-Reference to Related Application

5           This application is based on and claims priority to U.S. Provisional Application No. 60/864,480, filed November 6, 2006.

Field of the Invention

10           This invention concerns fire suppression systems using devices for emitting two or more extinguishing agents in a flow stream projected away from the device onto a fire.

15           Background of the Invention

          Fire control and suppression sprinkler systems generally include a plurality of individual sprinkler heads which are usually ceiling mounted about the area to be protected. The sprinkler heads are normally  
20 maintained in a closed condition and include a thermally responsive sensing member to determine when a fire condition has occurred. Upon actuation of the thermally responsive member, the sprinkler head is opened, permitting pressurized water at each of the  
25 individual sprinkler heads to freely flow therethrough for extinguishing the fire. The individual sprinkler heads are spaced apart from each other by distances determined by the type of protection they are intended to provide (e.g., light or ordinary hazard conditions)  
30 and the ratings of the individual sprinklers, as

determined by industry accepted rating agencies such as Underwriters Laboratories, Inc., Factory Mutual Research Corp. and/or the National Fire Protection Association.

5

In order to minimize the delay between thermal actuation and proper dispensing of water by the sprinkler head, the piping that connects the sprinkler heads to the water source is, in many instances, at all  
10 times filled with water. This is known as a wet system, with the water being immediately available at the sprinkler head upon its thermal actuation. However, there are many situations in which the sprinkler system is installed in an unheated area, such  
15 as warehouses. In those situations, if a wet system is used, and in particular, since the water is not flowing within the piping system over long periods of time, there is a danger of the water within the pipes freezing. This will not only adversely affect the  
20 operation of the sprinkler system should the sprinkler heads be thermally actuated while there may be ice blockage within the pipes but, such freezing, if extensive, can result in the bursting of the pipes, thereby destroying the sprinkler system. Accordingly,  
25 in those situations, it is the conventional practice to have the piping devoid of any water during its non-activated condition. This is known as a dry fire protection system.

30

When actuated, traditional sprinkler heads release a spray of fire suppressing liquid, such as water, onto

the area of the fire. The water spray, while somewhat effective, has several disadvantages. The water droplets comprising the spray are relatively large and will cause water damage to the furnishings or goods in the burning region. The water spray also exhibits limited modes of fire suppression. For example, the spray, being composed of relatively large droplets providing a small total surface area, does not efficiently absorb heat and therefore cannot operate efficiently to prevent spread of the fire by lowering the temperature of the ambient air around the fire. Large droplets also do not block radiative heat transfer effectively, thereby allowing the fire to spread by this mode. The spray furthermore does not efficiently displace oxygen from the ambient air around the fire, nor is there usually sufficient downward momentum of the droplets to overcome the smoke plume and attack the base of the fire.

With these disadvantages in mind, devices, such as resonance tubes, which atomize a fire suppressing liquid, have been considered as replacements for traditional sprinkler heads. Resonance tubes use acoustic energy, generated by an oscillatory pressure wave interaction between a gas jet and a cavity, to atomize a liquid that is injected into the region near the resonance tube where the acoustic energy is present.

Unfortunately, resonance tubes of known design and operational mode generally do not have the fluid flow

characteristics required to be effective in fire protection applications. The volume of flow from the resonance tube tends to be inadequate, and the water particles generated by the atomization process have relatively low velocities. As a result, these water particles are decelerated significantly within about 8 to 16 inches of the sprinkler head and cannot overcome the plume of rising combustion gas generated by a fire. Thus, the water particles cannot get to the fire source for effective fire suppression. Furthermore, the water particle size generated by the atomization is ineffective at reducing the oxygen content to suppress a fire if the ambient temperature is below 55°C. Additionally, known resonance tubes require relatively large gas volumes delivered at high pressure. This produces unstable gas flow which generates significant acoustic energy and separates from deflector surfaces across which it travels, leading to inefficient atomization of the water.

20

Systems which use only an inert gas to extinguish a fire also suffer certain disadvantages, the primary disadvantage being the reduction in oxygen concentration necessary to extinguish a fire. For example, a gaseous system that uses pure nitrogen will not extinguish flames until the oxygen content at the fire is 12% or lower. This concentration is significantly less than the known safe breathable limit of 15%. Persons without breathing apparatus exposed to an oxygen concentration of 12% have less than 5 minutes before they lose consciousness for lack of oxygen. At

30

oxygen concentration of 10% the exposure limit is about one minute. Thus, such systems present a hazard to persons trying to escape or fight the fire.

5           There is clearly a need for a fire suppression system having an atomizing emitter that can discharge both liquid and gaseous extinguishing agents and which operates more efficiently than known resonance tubes. Such an emitter would ideally use smaller volumes of  
10 gas at lower pressures to produce sufficient volume of atomized liquid particles having a smaller size distribution while maintaining significant momentum upon discharge so that the liquid particles may overcome the fire smoke plume and be more effective at  
15 fire suppression.

#### Summary of the Invention

The invention concerns a fire suppression system comprising a gaseous extinguishing agent and a liquid  
20 extinguishing agent. At least one emitter is used to atomize and entrain the liquid extinguishing agent in the gaseous extinguishing agent and discharge the gaseous and liquid extinguishing agents on a fire. A gas conduit conducts the gaseous extinguishing agent to  
25 the emitter. A piping network conducts the liquid extinguishing agent to the emitter. A first valve in the gas conduit controls pressure and flow rate of the gaseous extinguishing agent to the emitter. A second valve in the piping network controls pressure and flow  
30 rate of the liquid extinguishing agent to the emitter. A pressure transducer measures pressure within the gas

conduit. A fire detection device is positioned proximate to the emitter. A control system is in communication with the first and second valves, the pressure transducer and the fire detection device. The control system receives signals from the pressure transducer and the fire detection device and opens the valves in response to a signal indicative of a fire from the fire detection device. The control system actuates the first valve so as to maintain a predetermined pressure of the gaseous extinguishing agent within the gas conduit for operation of the emitter.

Preferably, the emitter comprises a nozzle having an inlet connected with the gas conduit downstream of the first valve and an outlet. A duct is connected in fluid communication with the piping network downstream of the second valve. The duct has an exit orifice positioned adjacent to the outlet. A deflector surface is positioned facing the outlet in spaced relation thereto. The deflector surface has a first surface portion oriented substantially perpendicularly to the nozzle and a second surface portion positioned adjacent to the first surface portion and oriented non-perpendicularly to the nozzle. The liquid extinguishing agent is dischargeable from the orifice, and the gaseous extinguishing agent is dischargeable from the nozzle outlet. The liquid extinguishing agent is entrained with the gaseous extinguishing agent and atomized thereby forming a liquid-gas stream that

impinges on the deflector surface and flows away therefrom onto the fire.

Preferably, the deflector surface is positioned so  
5 that the gaseous extinguishing agent forms a first shock front between the outlet and the deflector surface, and a second shock front is formed proximate to the deflector surface. The duct is positioned and oriented such that the liquid extinguishing agent,  
10 discharged from the exit orifice, is entrained with the gaseous extinguishing agent proximate to one of the shock fronts. The deflector surface may also be positioned so that shock diamonds form in the liquid-gas stream.

15

The invention also encompasses a method of operating a fire suppression system. The system has an emitter comprising a nozzle having an inlet connected in fluid communication with a pressurized source of  
20 gaseous extinguishing agent and an outlet. A duct is connected in fluid communication with a pressurized source of liquid extinguishing agent. The duct has an exit orifice positioned adjacent to the outlet. A deflector surface is positioned facing the outlet in  
25 spaced relation thereto. The method comprises:

(a) discharging the liquid extinguishing agent from the exit orifice;

(b) discharging the gaseous extinguishing agent from the outlet;

30 (c) establishing a first shock front between the outlet and the deflector surface;

(d) establishing a second shock front proximate to the deflector surface;

(e) entraining the liquid extinguishing agent in the gaseous extinguishing agent to form a liquid-gas  
5 stream; and

(f) projecting the liquid-gas stream from the emitter.

The method may also include establishing a  
10 plurality of shock diamonds in the liquid-gas stream.

The liquid extinguishing agent may be entrained with the gaseous extinguishing agent proximate to one of the shock fronts.

15

#### Brief Description of the Drawings

Figures 1 and 1A are schematic diagrams illustrating exemplary embodiments of dual extinguishment fire suppression systems according to  
20 the invention;

Figure 2 is a longitudinal sectional view of a high velocity low pressure emitter used in the fire suppression system shown in Figure 1;

25

Figure 3 is a longitudinal sectional view showing a component of the emitter depicted in Figure 2;

Figure 4 is a longitudinal sectional view showing  
30 a component of the emitter depicted in Figure 2;

Figure 5 is a longitudinal sectional view showing a component of the emitter depicted in Figure 2;

Figure 6 is a longitudinal sectional view showing  
5 a component of the emitter depicted in Figure 2;

Figure 7 is a diagram depicting fluid flow from the emitter based upon a Schlieren photograph of the emitter shown in Figure 2 in operation; and  
10

Figure 8 is a diagram depicting predicted fluid flow for another embodiment of the emitter.

#### Detailed Description of the Embodiments

15 Figure 1 illustrates, in schematic form, an example dual extinguishment fire suppression system 11 according to the invention. System 11 includes a plurality of high velocity low pressure emitters 10, described in detail below. Emitters 10 are arranged in  
20 a potential fire hazard zone 13, the system comprising one or more such zones, each zone having its own bank of emitters. For clarity, only one zone is described herein, it being understood that the description is applicable to additional fire hazard zones as shown.

25 The emitters 10 are connected via a piping network 15 to a source of pressurized liquid extinguishing agent 17. Examples of practical liquid agents include synthetic compounds such as heptafluoropropane (sold  
30 under the tradename Novec™ 1230), bromochloro-difluoromethane and bromotrifluoromethane. Water is

also feasible, and especially de-ionized water for use near charged electrical equipment. De-ionized water reduces electrical arcing due to its low conductivity.

5           It is preferred to control the flow of liquid to each emitter 10 using individual flow control devices 71 positioned immediately upstream of each emitter. Preferably the individual control devices include a flow cartridge and a strainer to protect the flow  
10 cartridge and the emitter. The flow cartridge operates autonomously to provide a constant flow rate over a known pressure range and is useful to compensate for variations in water pressure at the source as well as frictional head loss due to long pipe runs and  
15 intervening joints such as elbows. Proper operation of the emitters, described below, is ensured by controlling the flow at each emitter. A liquid control valve 19 may be used to control the flow of liquid from the source 17 to the emitters 10, with fine control of  
20 the flow rate managed by the individual flow control devices 71.

The emitters are also in fluid communication with a source of pressurized gaseous extinguishing agent 21  
25 through a gas conduit network 23. Candidate gaseous extinguishing agents include mixtures of atmospheric gases such as Inergen™ (52% nitrogen, 40% argon, 8% carbon dioxide) and Argonite™ (50% argon and 50% nitrogen) as well as synthetic compounds such as  
30 fluoroform, 1,1,1,2,2-pentafluoroethane and 1,1,1,2,3,3,3-heptafluoropropane. The gaseous

extinguishing agent may be maintained in banks of high-pressure cylinders 25 as shown in Figure 1. Cylinders 25 may be pressurized up to 2,500 psig. For large systems which require large volumes of gas, one or more  
5 lower pressure tanks (about 350 psig) having volumes on the order of 30,000 gallons may be used. Alternately, large volume high pressure tanks (for example 30 cubic feet at a pressure of 2600 psi) may also be used. In a further practical embodiment, shown in Figure 1A, the  
10 gaseous extinguishing agent may be stored in a single tank 73 common to all emitters 10 in all of the fire hazard zones 13.

Valves 27 of cylinders 25 (or tank 73) are  
15 preferably maintained in an open state in communication with a high pressure manifold 29. Gas flow rate and pressure from the manifold to the gas conduit 23 are controlled by a high pressure gas control valve 31. Pressure in the conduit 23 downstream of the high  
20 pressure control valve 31 is measured by a pressure transducer 33. Flow of gas to the emitters 10 in each fire hazard zone 13 is further controlled by a low pressure valve 35 downstream of the pressure transducer.

25

Each fire hazard zone 13 is monitored by one or more fire detection devices 37. These detection devices operate in any of the various known modes for fire detection, such as sensing of flame, heat, rate of  
30 temperature rise, smoke detection or combinations thereof.

The system components thus described are coordinated and controlled by a control system 39, which comprises, for example, a microprocessor 41  
5 having a control panel display (not shown), resident software, and a programmable logic controller 43. The control system communicates with the system components to receive information and issue control commands as follows.

10

Each cylinder valve 27 is monitored as to its status (open or closed) by a supervisory loop 45 that communicates with the microprocessor 41, which provides a visual indication of the cylinder valve status.  
15 Liquid control valve 19 is also in communication with microprocessor 41 via a communication line 47, which allows the valve 19 to be monitored and controlled (opened and closed) by the control system. Similarly, gas control valve 35 communicates with the control  
20 system via a communication line 49, and the fire detection devices 37 also communicate with the control system via communication lines 51. The pressure transducer 35 provides its signals to the programmable logic controller 43 over communication line 53. The  
25 programmable logic controller is also in communication with the high pressure gas valve 31 over communication line 55, and with the microprocessor 41 over communication line 57.

30

In operation, fire detectors 37 sense a fire event and provide a signal to the microprocessor 41 over

communication line 51. The microprocessor actuates the logic controller 43. Note that controller 43 may be a separate controller or an integral part of the high pressure control valve 31. The logic controller 43 receives a signal from the pressure transducer 33 via communication line 53 indicative of the pressure in the gas conduit 23. The logic controller 43 opens the high pressure gas valve 31 while the microprocessor 41 opens the gas control valve 35 and the liquid control valve 19 using respective communication lines 49 and 47. Gaseous extinguishing agent from tanks 25 and liquid extinguishing agent from source 17, are thus permitted to flow through gas conduit 23 and liquid piping network 15 respectively. Preferred liquid extinguishing agent pressure for proper operation of the emitters 10 is between about 1 psig and about 50 psig as described below. The flow cartridges or other such flow control devices 71 maintain the required liquid flow rate. The logic controller 43 operates valve 31 to maintain the correct pressure of gaseous extinguishing agent (between about 29 psia and about 60 psia) and flow rate to operate the emitters 10 within the parameters as described below. For a 1/2 inch emitter tests show nitrogen supplied at pressure of 25 psi and a flow rate of 150 scfm is effective.

The dual extinguishing agents discharged by the emitters 10 work together to extinguish the fire in the presence of an oxygen concentration of no lower than 15%. This is significantly better than various gas only systems such as those which use nitrogen and

require a reduction of oxygen concentration of 12% or lower before the fire will be extinguished. It is advantageous to maintain an oxygen concentration of at least 15% if possible, as 15% is a known safe level and provides a breathable atmosphere. In action, the gaseous extinguishing agent reduces the fire plume temperature to the critical adiabatic temperature of the fire. (This is the temperature at which the fire will self-extinguish.) In addition to lowering the fire plume temperature, the gaseous component acts to decrease the oxygen concentration as well. The liquid extinguishing agent acts as a heat sink to absorb heat from the fire and thereby suppress it.

Upon sensing that the fire is extinguished, the microprocessor 41 closes the gas and liquid valves 35 and 19, and the logic controller 43 closes the high pressure control valve 31. The control system 39 continues to monitor all the fire hazard zones 13, and in the event of another fire or the re-flashing of the initial fire the above described sequence is repeated.

Figure 2 shows a longitudinal sectional view of a high velocity low pressure emitter 10 according to the invention. Emitter 10 comprises a convergent nozzle 12 having an inlet 14 and an outlet 16. Outlet 16 may range in diameter between about 1/8 inch to about 1 inch for many applications. Inlet 14 is in fluid communication with a pressurized supply of gaseous extinguishing agent, for example, the cylinders 25 (see also Figure 1), that provides the gaseous extinguishing

agent to the nozzle at a predetermined pressure and flow rate. It is advantageous that the nozzle 12 have a curved convergent inner surface 20, although other shapes, such as a linear tapered surface, are also  
5 feasible.

A deflector surface 22 is positioned in spaced apart relation with the nozzle 12, a gap 24 being established between the deflector surface and the  
10 nozzle outlet. The gap may range in size between about 1/10 inches to about 3/4 inches. The deflector surface 22 is held in spaced relation from the nozzle by one or more support legs 26.

15 Preferably, deflector surface 22 comprises a flat surface portion 28 substantially aligned with the nozzle outlet 16, and an angled surface portion 30 contiguous with and surrounding the flat portion. Flat portion 28 is substantially perpendicular to the gas  
20 flow from nozzle 12, and has a minimum diameter approximately equal to the diameter of the outlet 16. The angled portion 30 is oriented at a sweep back angle 32 from the flat portion. The sweep back angle may range between about 15° and about 45° and, along with  
25 the size of gap 24, determines the dispersion pattern of the flow from the emitter.

Deflector surface 22 may have other shapes, such as the curved upper edge 34 shown in Figure 3 and the  
30 curved edge 36 shown in Figure 4. As shown in Figures 5 and 6, the deflector surface 22 may also include a

closed end resonance tube 38 surrounded by a flat portion 40 and a swept back, angled portion 42 (Figure 5) or a curved portion 44 (Figure 6). The diameter and depth of the resonance cavity may be approximately  
5 equal to the diameter of outlet 16.

With reference again to Figure 2, an annular chamber 46 surrounds nozzle 12. Chamber 46 is in fluid communication with a pressurized liquid supply, for  
10 example, the liquid extinguishing agent source 17 of Figure 1 that provides the liquid extinguishing agent to the chamber at a predetermined pressure and flow rate. A plurality of ducts 50 extend from the chamber 46. Each duct has an exit orifice 52 positioned  
15 adjacent to nozzle outlet 16. The exit orifices have a diameter of about 1/32 inch to about 1/8 inch. Preferred distances between the nozzle outlet 16 and the exit orifices 52 range between about 1/64 inch to about 1/8 inch as measured along a radius line from the  
20 edge of the nozzle outlet to the closest edge of the exit orifice. Liquid extinguishing agent flows from the pressurized supply 17 into the chamber 46 and through the ducts 50, exiting from each orifice 52 where it is atomized by the flow of gaseous  
25 extinguishing agent from the pressurized gas supply that flows through the nozzle 12 and exits through the nozzle outlet 16 as described in detail below.

Emitter 10, when configured for use in a fire  
30 suppression system, is designed to operate with a preferred gas pressure between about 29 psia to about

60 psia at the nozzle inlet 14 and a preferred liquid extinguishing agent pressure between about 1 psig and about 50 psig in chamber 46.

5           Operation of the emitter 10 is described with reference to Figure 7 which is a drawing based upon Schlieren photographic analysis of an operating emitter.

10           Gaseous extinguishing agent 85 exits the nozzle outlet 16 at about Mach 1 and impinges on the deflector surface 22. Simultaneously, liquid extinguishing agent 87 is discharged from exit orifices 52.

15           Interaction between the gaseous extinguishing agent 85 and the deflector surface 22 establishes a first shock front 54 between the nozzle outlet 16 and the deflector surface 22. A shock front is a region of flow transition from supersonic to subsonic velocity.  
20           Liquid extinguishing agent 87 exiting the orifices 52 does not enter the region of the first shock front 54 in this mode of operation of the emitter.

          A second shock front 56 forms proximate to the  
25           deflector surface at the border between the flat surface portion 28 and the angled surface portion 30. Liquid extinguishing agent 87 discharged from the orifices 52 is entrained with the gaseous extinguishing agent 85 proximate to the second shock front 56 forming  
30           a liquid-gas stream 60. One method of entrainment is to use the pressure differential between the pressure

in the gas flow jet and the ambient. Shock diamonds 58 form in a region along the angled portion 30, the shock diamonds being confined within the liquid-gas stream 60, which projects outwardly and downwardly from the emitter. The shock diamonds are also transition regions between super and subsonic flow velocity and are the result of the gas flow being overexpanded as it exits the nozzle. Overexpanded flow describes a flow regime wherein the external pressure (i.e., the ambient atmospheric pressure in this case) is higher than the gas exit pressure at the nozzle. This produces oblique shock waves which reflect from the free jet boundary 89 marking the limit between the liquid-gas stream 60 and the ambient atmosphere. The oblique shock waves are reflected toward one another to create the shock diamonds.

Significant shear forces are produced in the liquid-gas stream 60, which ideally does not separate from the deflector surface, although the emitter is still effective if separation occurs as shown at 60a. The liquid extinguishing agent entrained proximate to the second shock front 56 is subjected to these shear forces which are the primary mechanism for atomization. The liquid extinguishing agent also encounters the shock diamonds 58, which are a secondary source of atomization.

Thus, the emitter 10 operates with multiple mechanisms of atomization which produce liquid particles 62 less than 20  $\mu\text{m}$  in diameter, the majority

of the particles being measured at less than 10  $\mu\text{m}$ .  
The smaller droplets are buoyant in air. This  
characteristic allows them to maintain proximity to the  
fire source for greater fire suppression effect.

5 Furthermore, the particles maintain significant  
downward momentum, allowing the liquid-gas stream 60 to  
overcome the rising plume of combustion gases resulting  
from a fire. Measurements show the liquid-gas stream  
having a velocity of about 7,000 ft/min 18 inches from  
10 the emitter, and a velocity greater than 1,700 ft/min 8  
feet from the emitter. The flow from the emitter is  
observed to impinge on the floor of the room in which  
it is operated. The sweep back angle 32 of the angled  
portion 30 of the deflector surface 22 provides  
15 significant control over the included angle 64 of the  
liquid-gas stream 60. Included angles of about  $120^\circ$   
are achievable. Additional control over the dispersion  
pattern of the flow is accomplished by adjusting the  
gap 24 between the nozzle outlet 16 and the deflector  
20 surface.

During emitter operation it is further observed  
that the smoke layer that accumulates at the ceiling of  
a room during a fire is drawn into the stream of  
25 gaseous extinguishing agent 85 exiting the nozzle and  
is entrained in the flow 60. This adds to the multiple  
modes of extinguishment characteristic of the emitter  
as described below.

30 The emitter causes a temperature drop due to the  
atomization of the liquid extinguishing agent into the

extremely small particle sizes described above. This  
absorbs heat and helps mitigate spread of combustion.  
The flow of liquid extinguishing agent entrained in the  
flow of gaseous extinguishing agent replace the oxygen  
5 in the room with gases that cannot support combustion.  
Further oxygen depleted gases in the form of the smoke  
layer that is entrained in the flow also contributes to  
the oxygen starvation of the fire. It is observed,  
however, that the oxygen level in the room where the  
10 emitter is deployed does not drop below about 15%. The  
liquid extinguishing agent particles and the entrained  
smoke create a fog that blocks radiative heat transfer  
from the fire, thus, mitigating spread of combustion by  
this mode of heat transfer. The mixing and the  
15 turbulence created by the emitter also helps lower the  
temperature in the region around the fire.

The emitter is unlike resonance tubes in that it  
does not produce significant acoustic energy. Jet  
20 noise (the sound generated by air moving over an  
object) is the only acoustic output from the emitter.  
The emitter's jet noise has no significant frequency  
components higher than about 6 kHz (half the operating  
frequency of well known types of resonance tubes) and  
25 does not contribute significantly to atomization.

Furthermore, the flow from the emitter is stable  
and does not separate from the deflector surface (or  
experiences delayed separation as shown at 60a) unlike  
30 the flow from resonance tubes, which is unstable and

separates from the deflector surface, thus leading to inefficient atomization or even loss of atomization.

Another emitter embodiment 101 is shown in Figure  
5 8. Emitter 101 has ducts 50 that are angularly oriented toward the nozzle 12. The ducts are angularly oriented to direct the liquid extinguishing agent 87 toward the gaseous extinguishing agent 85 so as to entrain the liquid in the gas proximate to the first  
10 shock front 54. It is believed that this arrangement will add yet another region of atomization in the creation of the liquid-gas stream 60 projected from the emitter 11.

15 Fire suppression systems using emitters and dual extinguishing agents according to the invention achieve multiple fire extinguishment modes which are well suited to control the spread of fire while using less gas and liquid than known systems which use water.  
20 Systems according to the invention are especially effective and efficient in ventilated fire conditions.

**CLAIMS**

What is claimed is:

- 5 1. A fire suppression system, comprising: a gaseous extinguishing agent; a liquid extinguishing agent; at least one emitter for atomizing and entraining said liquid extinguishing agent in said gaseous extinguishing agent and discharging said gaseous and liquid extinguishing agents on a fire; a gas conduit conducting said gaseous extinguishing agent to said emitter; a piping  
10 network conducting said liquid extinguishing agent to said emitter; a first valve in said gas conduit controlling pressure and flow rate of said gaseous extinguishing agent to said emitter; a second valve in said piping network controlling pressure and flow rate of said liquid extinguishing agent to said emitter; a pressure transducer measuring pressure within said gas conduit; a  
15 fire detection device positioned proximate to said emitter, said emitter comprising: a nozzle having an inlet and an outlet and an unobstructed bore therebetween, said outlet having a diameter, said inlet connected with said gas conduit downstream of said first valve; a duct connected in fluid communication with said piping network downstream of said second valve,  
20 said duct having an exit orifice positioned adjacent to said nozzle outlet; a deflector surface positioned facing said nozzle outlet, said deflector surface being positioned in spaced relation to said nozzle outlet and having a first surface portion comprising a flat surface oriented substantially perpendicularly to a gas flow from said nozzle and a second surface portion comprising an  
25 angled surface surrounding said flat surface, said flat surface having a wetted area defined by a minimum diameter approximately equal to said outlet diameter; and a control system in communication with said first and second valves, said pressure transducer and said fire detection device, said control system receiving signals from said pressure transducer and said fire detection  
30 device and opening said valves in response to a signal indicative of a fire from said fire detection device.

2. A system according to claim 1, further comprising: a plurality of compressed gas tanks comprising a source of pressurized gaseous extinguishing agent; and a high pressure manifold providing fluid communication between said compressed gas tanks and said gas conduit  
5 upstream of said first valve.
3. A system according to claim 1 or 2, further comprising a flow control device positioned in said piping network between said emitter and said second valve.
- 10 4. A system according to claim 3, wherein said flow control device comprises a flow cartridge.
5. A system according to any one of claims 1 to 3, further comprising: a plurality of said emitters distributed over a plurality of fire hazard zones; and a  
15 plurality of flow control devices positioned in said piping network between each one of said emitters and said second valve.
6. A system according to claim 5, wherein said flow control devices each comprise a flow cartridge.  
20
7. A system according to any one of claims 1 to 6, wherein said gaseous extinguishing agent has a pressure between about 29 psia and about 60 psia in said gas conduit.
- 25 8. A system according to any one of claims 1 to 7, wherein said liquid extinguishing agent has a pressure between about 1 psig and about 50 psig in said piping network.
9. A system according to any one of claims 1 to 8, wherein said duct is  
30 angularly oriented toward said nozzle.
10. A system according to any one of claims 1 to 9, wherein said liquid

extinguishing agent is entrained with said gaseous extinguishing agent proximate to a shock front.

11. A fire suppression system, comprising: a gaseous extinguishing agent; a  
5 liquid extinguishing agent; at least one emitter for atomizing and entraining  
said liquid extinguishing agent in said gaseous extinguishing agent and  
discharging said gaseous and liquid extinguishing agents on a fire; a gas  
conduit conducting said gaseous extinguishing agent to said emitter; a piping  
network conducting said liquid extinguishing agent to said emitter; a first valve  
10 in said gas conduit controlling pressure and flow rate of said gaseous  
extinguishing agent to said emitter; a second valve in said piping network  
controlling pressure and flow rate of said liquid extinguishing agent to said  
emitter; a pressure transducer measuring pressure within said gas conduit; a  
fire detection device positioned proximate to said emitter, said emitter  
15 comprising: a nozzle having an inlet and an outlet and an unobstructed bore  
therebetween, said outlet having a diameter, said inlet being connected in  
fluid communication with said gas conduit downstream of said first valve; a  
duct connected in fluid communication with said piping network downstream  
of said second valve, said duct having an exit orifice positioned adjacent to  
20 said nozzle outlet; a deflector surface positioned facing said nozzle outlet in  
spaced relation thereto and having a first surface portion comprising a flat  
surface oriented substantially perpendicularly to a gas flow from said nozzle  
and a second surface portion comprising a curved surface surrounding said  
flat surface, said flat surface having a wetted area defined by a minimum  
25 diameter approximately equal to said outlet diameter; and a control system in  
communication with said first and second valves, said pressure transducer  
and said fire detection device, said control system receiving signals from said  
pressure transducer and said fire detection device and opening said valves in  
response to a signal indicative of a fire from said fire detection device.

30

12. A system according to any one of claims 1 to 11, further comprising a closed end cavity positioned within said deflector surface and surrounded by said flat surface.

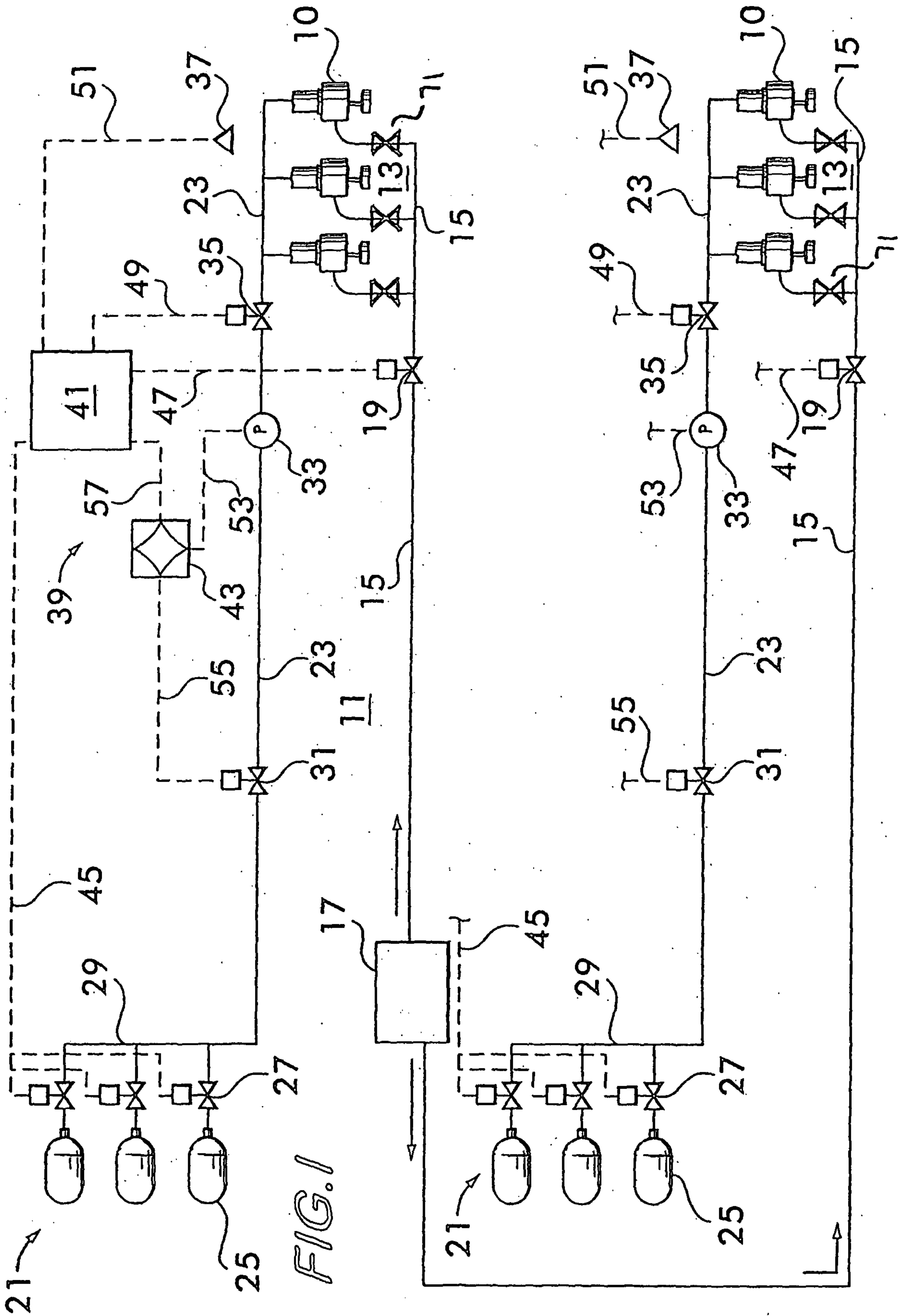
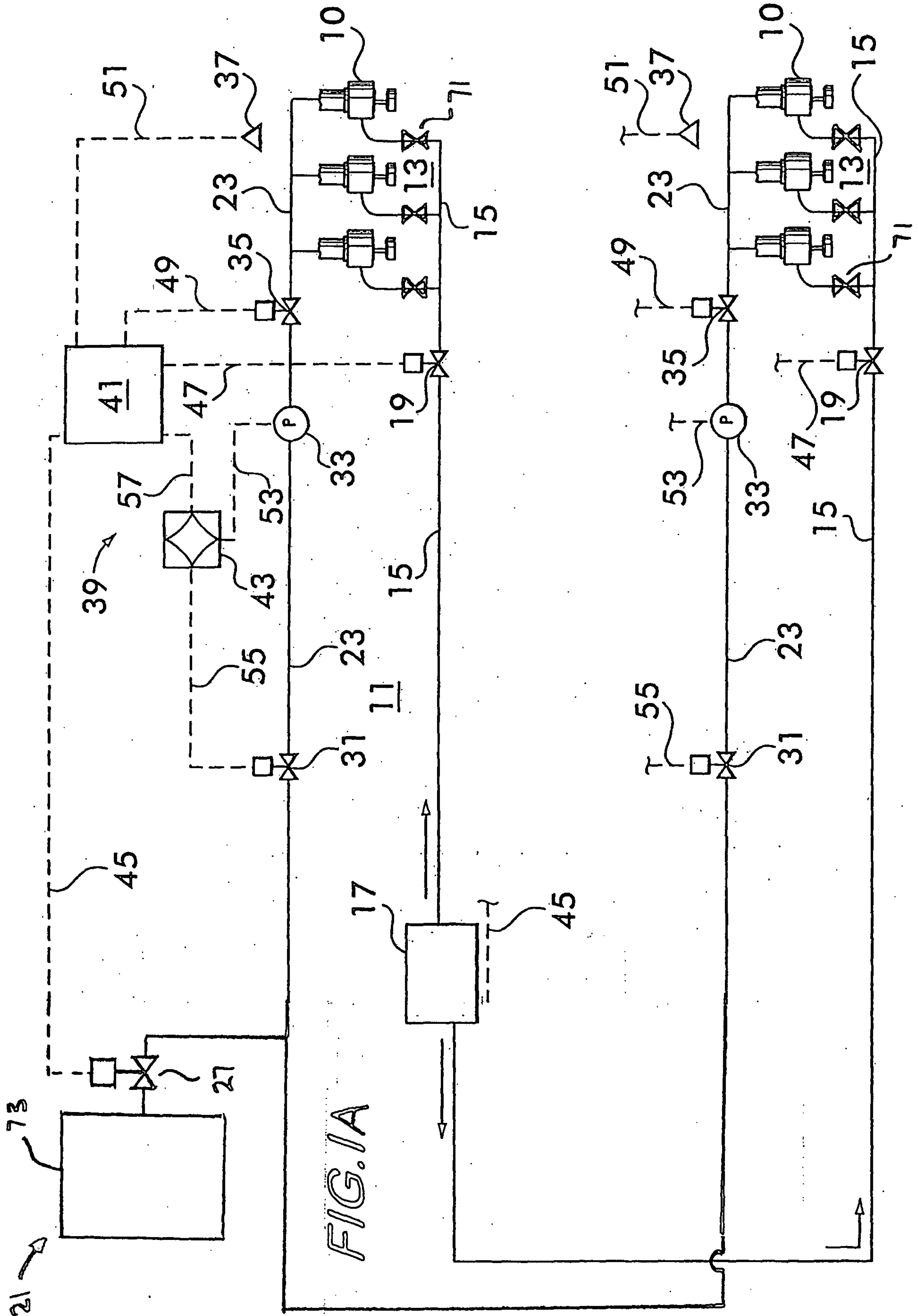
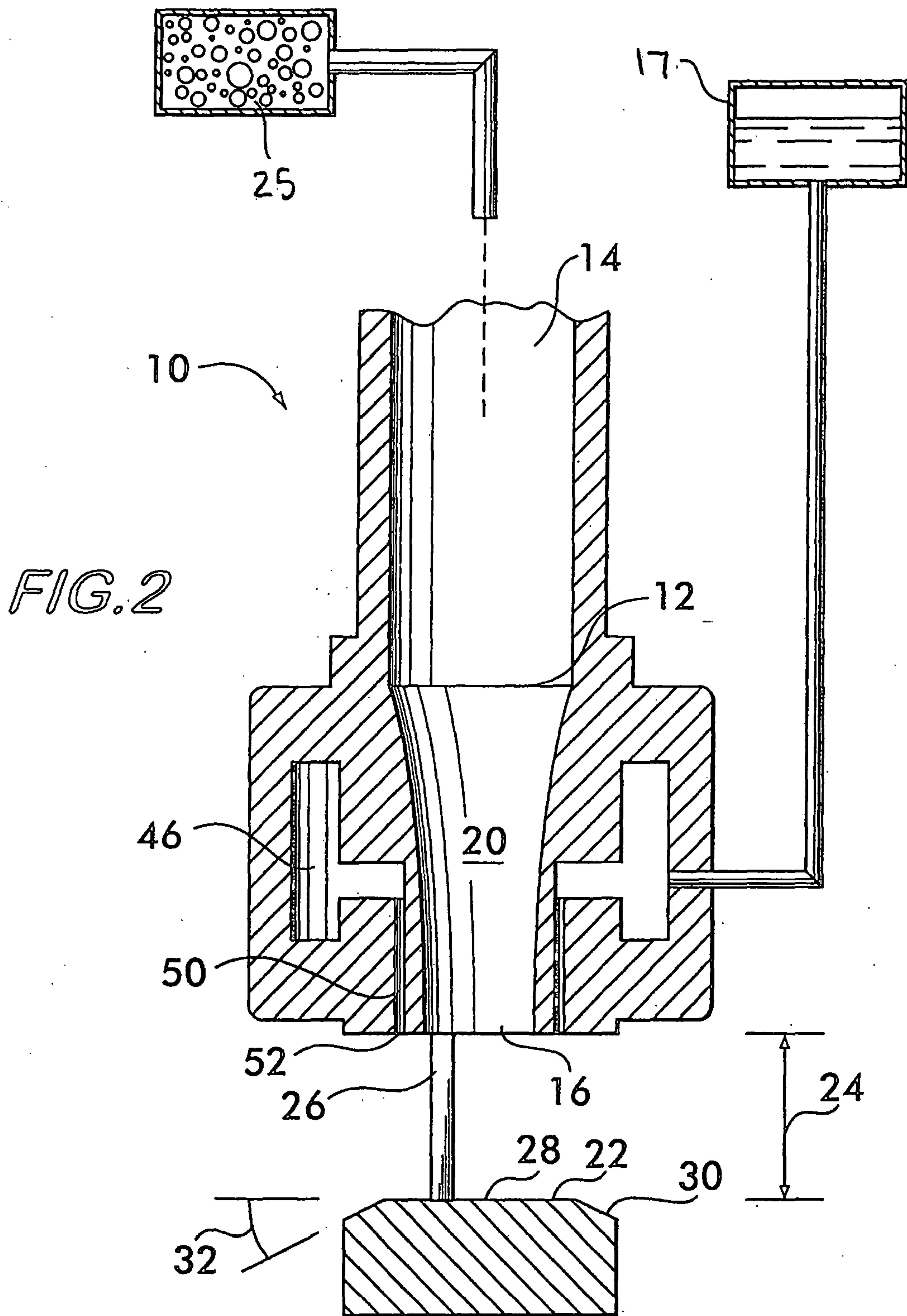
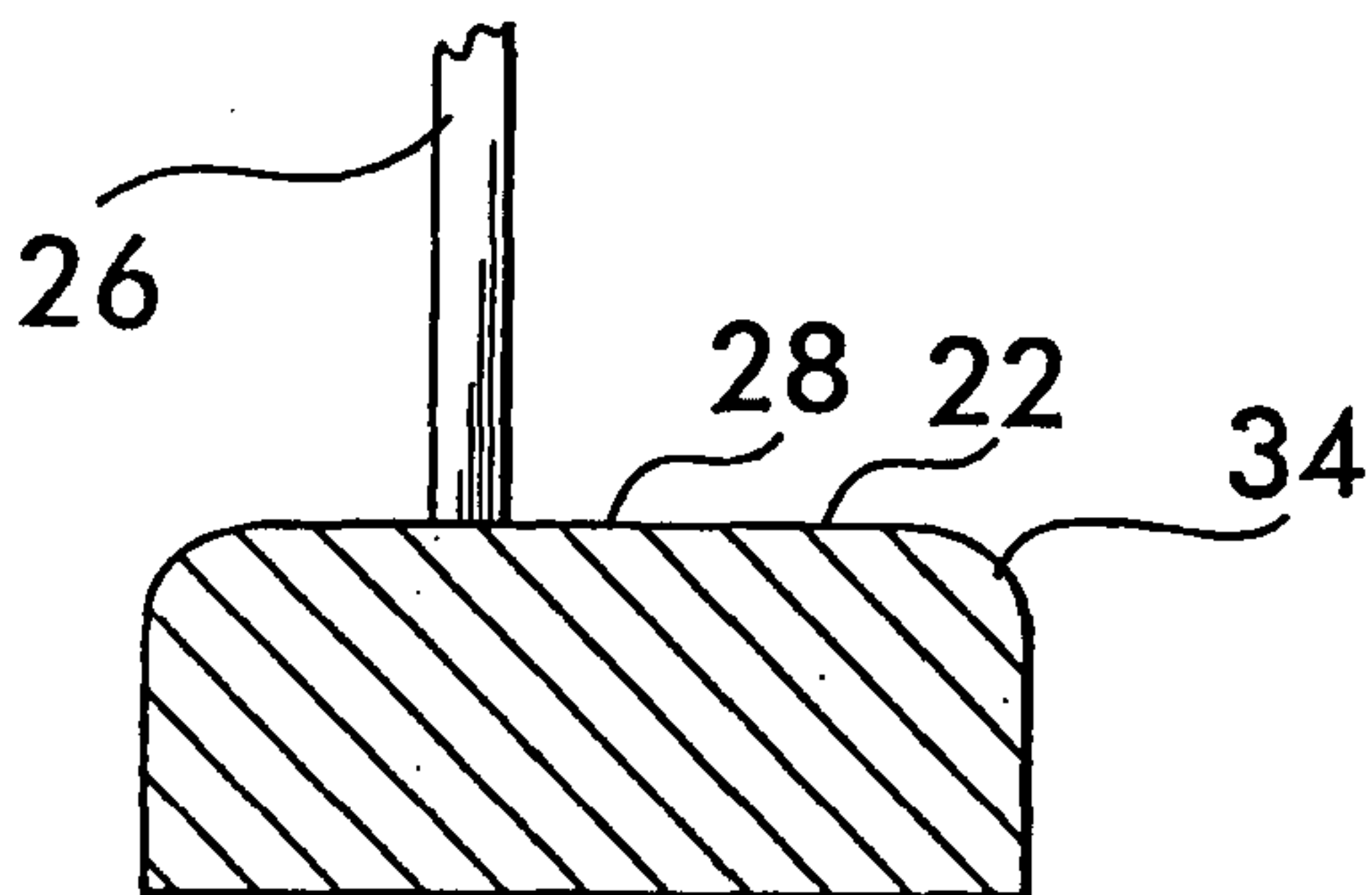


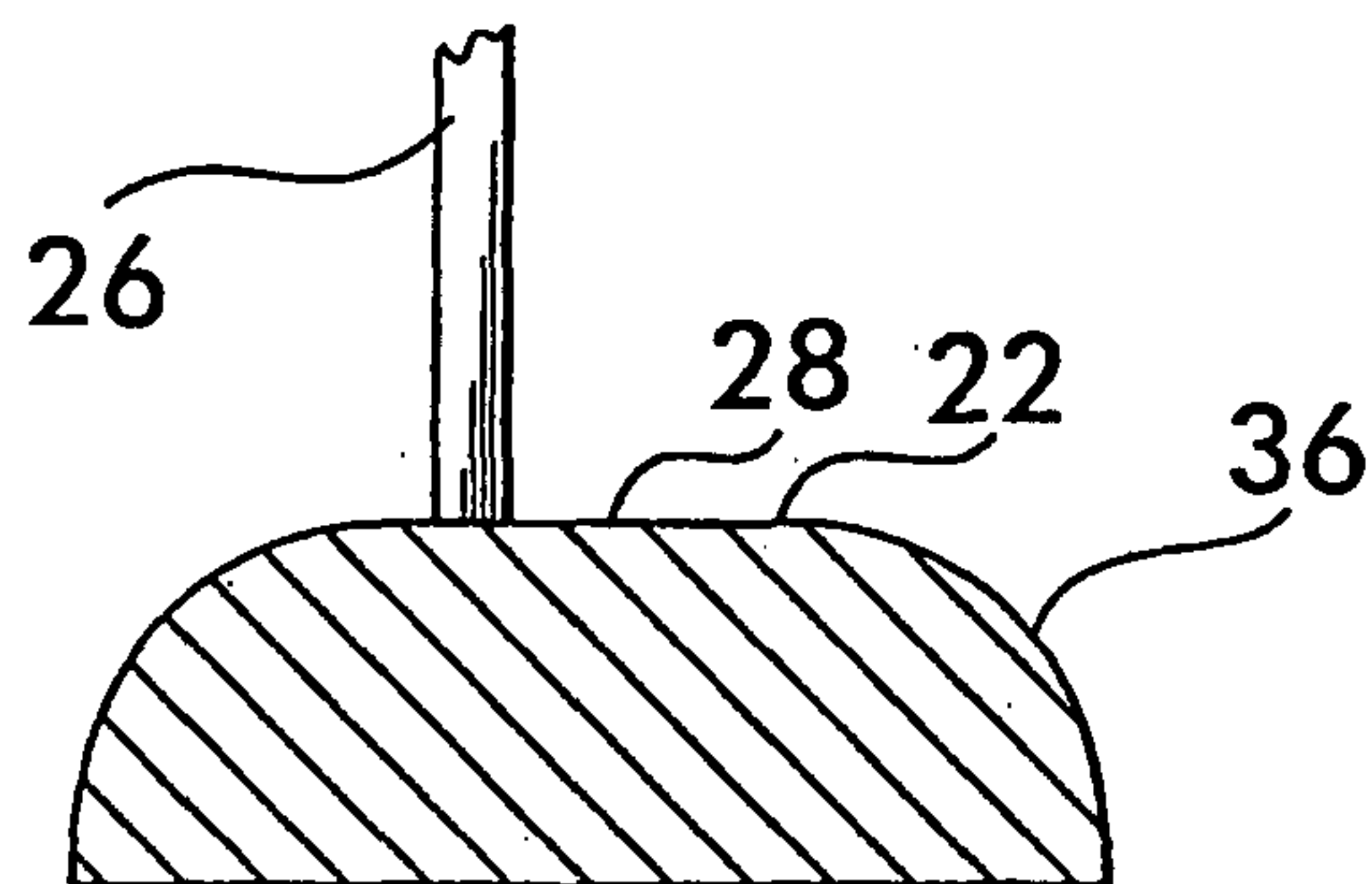
FIG. 1



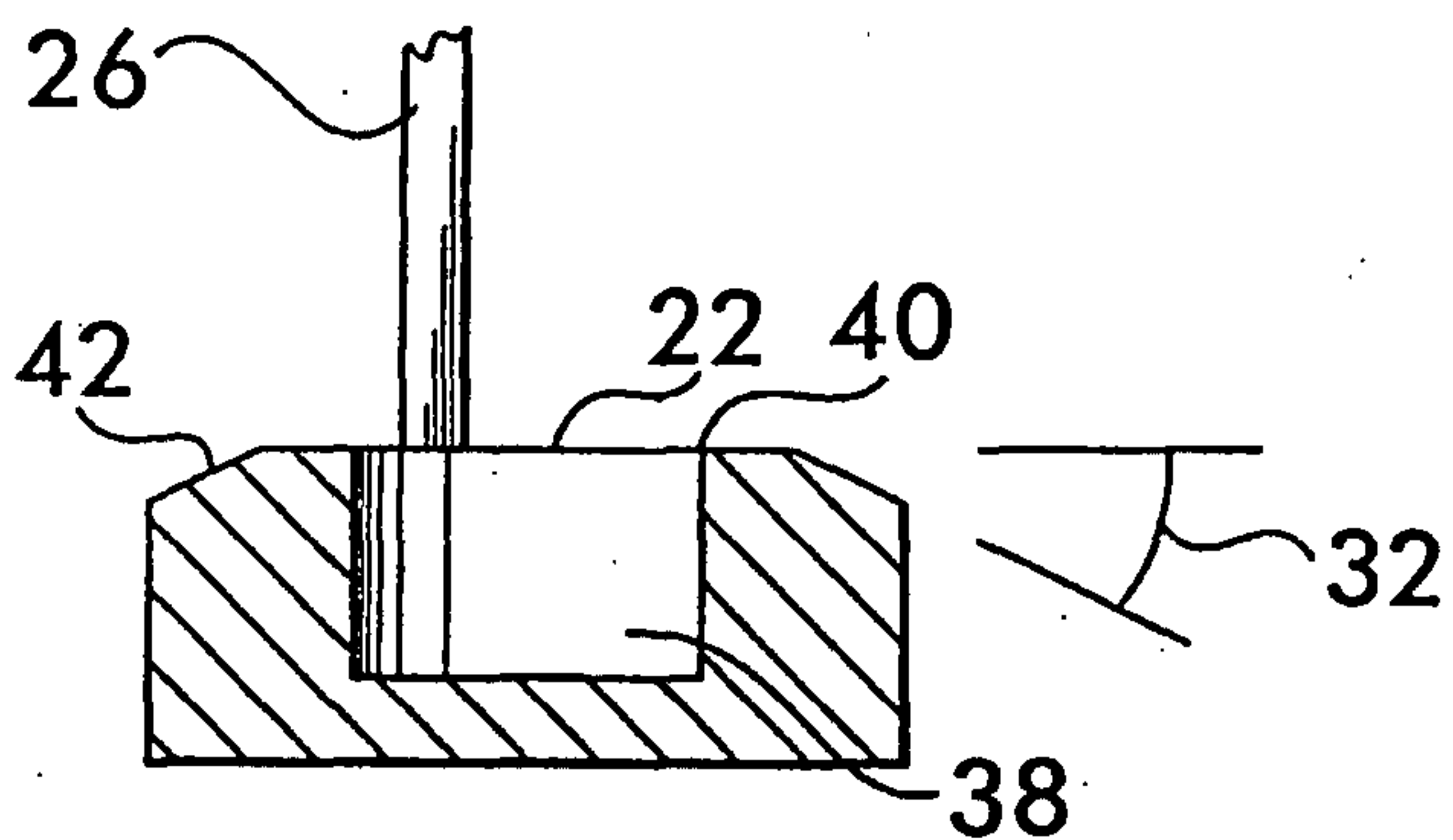




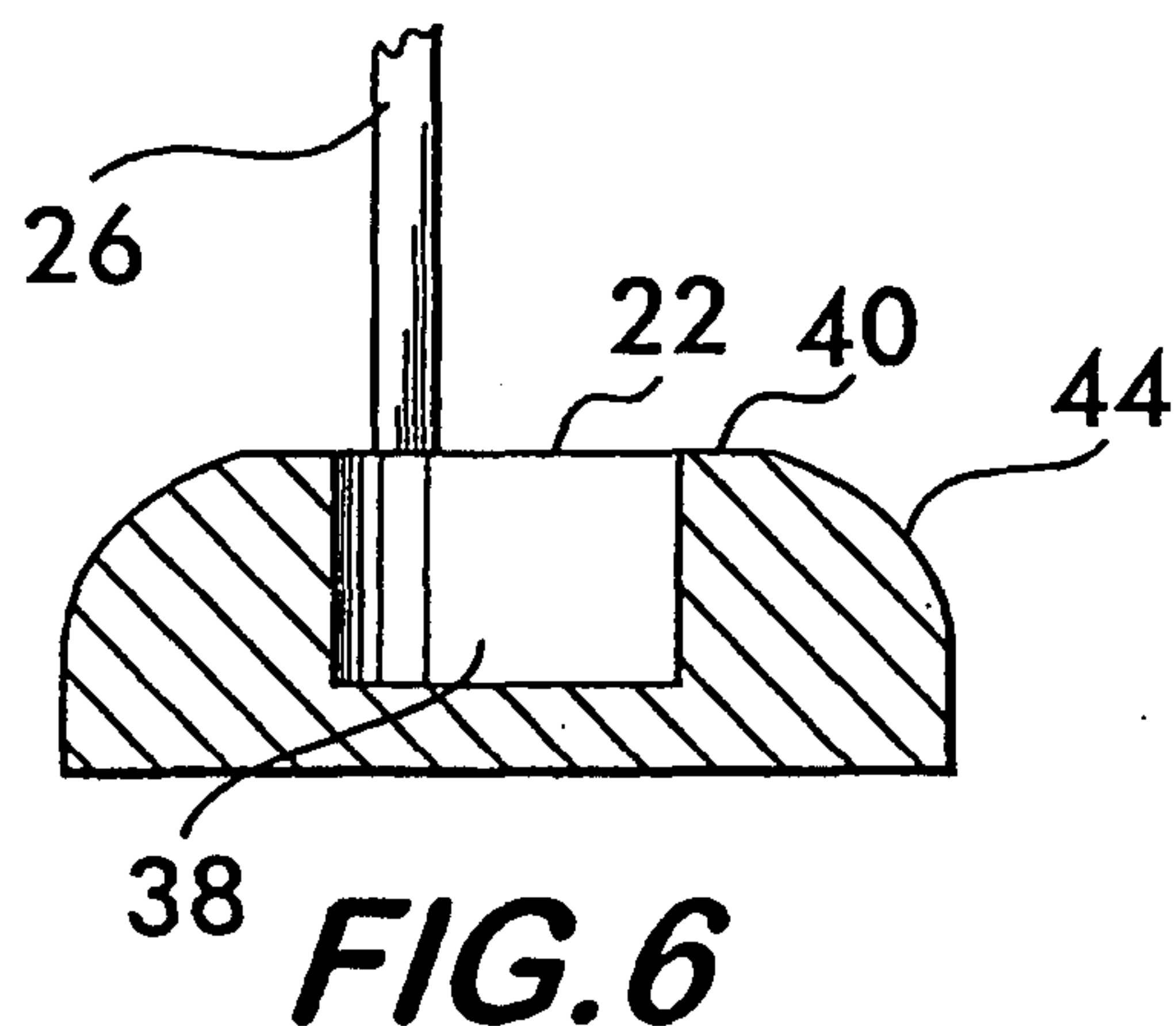
**FIG. 3**



**FIG. 4**



**FIG. 5**



**FIG. 6**

FIG. 7

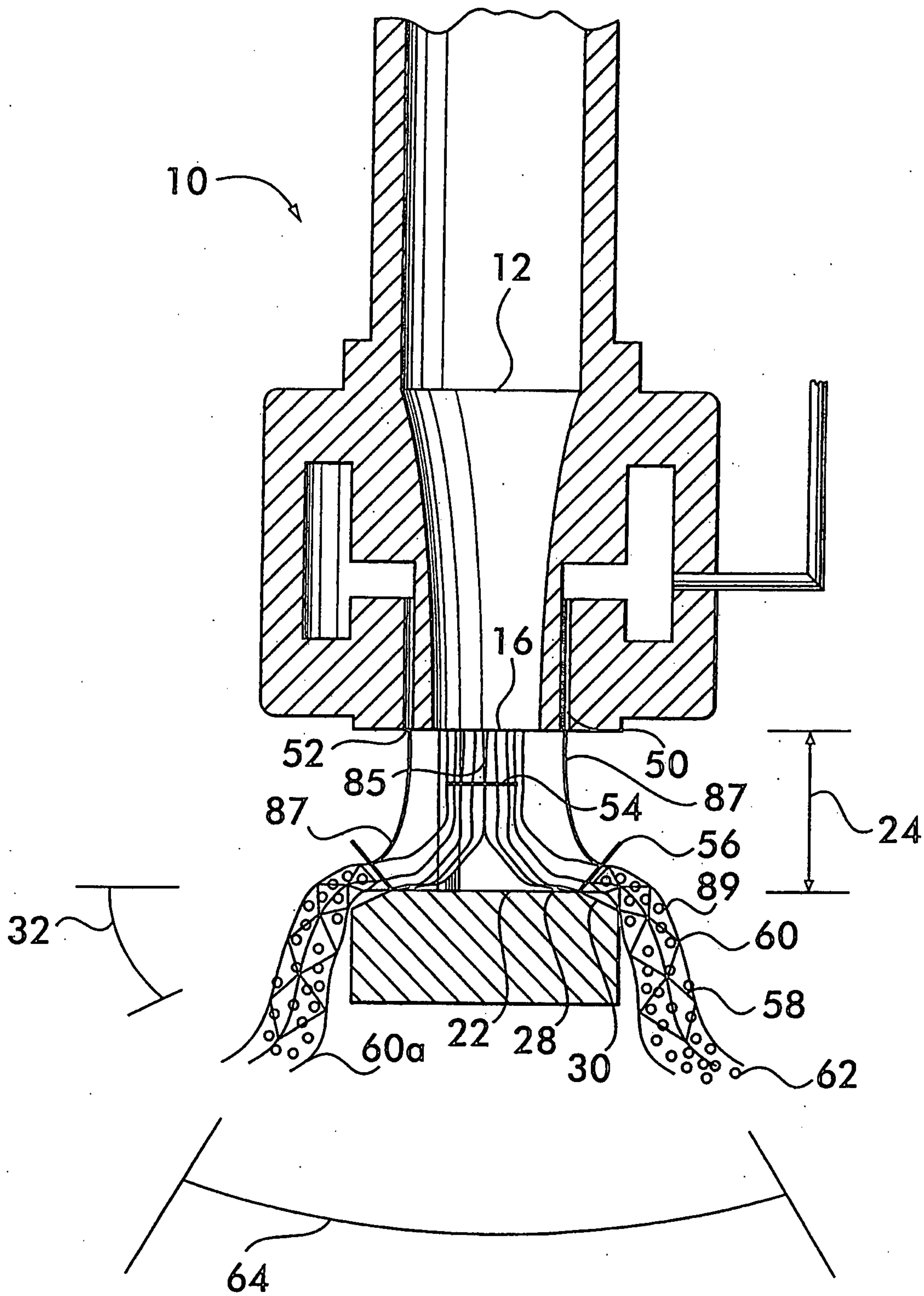


FIG. 8

