

**(12) STANDARD PATENT**  
**(19) AUSTRALIAN PATENT OFFICE**

(11) Application No. **AU 2013244983 B2**

(54) Title  
**Device for closing bags or the like, having improved tactile and sound effects, resultant bag, and production method**

(51) International Patent Classification(s)  
**B65D 33/25 (2006.01)**

(21) Application No: **2013244983** (22) Date of Filing: **2013.04.02**

(87) WIPO No: **WO13/150027**

(30) Priority Data

(31) Number	(32) Date	(33) Country
<b>1253041</b>	<b>2012.04.03</b>	<b>FR</b>

(43) Publication Date: **2013.10.10**

(44) Accepted Journal Date: **2017.08.10**

(71) Applicant(s)  
**S2F Flexico**

(72) Inventor(s)  
**Delasalle, William**

(74) Agent / Attorney  
**FPA Patent Attorneys Pty Ltd, Level 43 101 Collins Street, Melbourne, VIC, 3000, AU**

(56) Related Art  
**US 2006/0008184**  
**US 2004/0261229**  
**US 5509734**  
**US 6021557**  
**EP 0510797**  
**US 5647100**

(12) DEMANDE INTERNATIONALE PUBLIÉE EN VERTU DU TRAITÉ DE COOPÉRATION EN MATIÈRE DE BREVETS (PCT)

(19) Organisation Mondiale de la  
Propriété Intellectuelle  
Bureau international



WIPO | PCT



(10) Numéro de publication internationale

WO 2013/150027 A1

- (51) Classification internationale des brevets :  
B65D 33/25 (2006.01)
- (21) Numéro de la demande internationale :  
PCT/EP2013/056938
- (22) Date de dépôt international :  
2 avril 2013 (02.04.2013)
- (25) Langue de dépôt : français
- (26) Langue de publication : français
- (30) Données relatives à la priorité :  
1253041 3 avril 2012 (03.04.2012) FR
- (71) Déposant : S2F FLEXICO [FR/FR]; 1, route de Méru, F-60119 Henonville (FR).
- (72) Inventeur : DELASALLE, William; 7 rue de la Croix Mathieu, F-60119 Cresnes (FR).
- (74) Mandataire : REGIMBEAU; 20, rue de Chazelles, F-75847 Paris Cedex 17 (FR).
- (81) États désignés (sauf indication contraire, pour tout titre de protection nationale disponible) : AE, AG, AL, AM,

AO, AT, AU, AZ, BA, BB, BG, BH, BN, BR, BW, BY, BZ, CA, CH, CL, CN, CO, CR, CU, CZ, DE, DK, DM, DO, DZ, EC, EE, EG, ES, FI, GB, GD, GE, GH, GM, GT, HN, HR, HU, ID, IL, IN, IS, JP, KE, KG, KM, KN, KP, KR, KZ, LA, LC, LK, LR, LS, LT, LU, LY, MA, MD, ME, MG, MK, MN, MW, MX, MY, MZ, NA, NG, NI, NO, NZ, OM, PA, PE, PG, PH, PL, PT, QA, RO, RS, RU, RW, SC, SD, SE, SG, SK, SL, SM, ST, SV, SY, TH, TJ, TM, TN, TR, TT, TZ, UA, UG, US, UZ, VC, VN, ZA, ZM, ZW.

- (84) États désignés (sauf indication contraire, pour tout titre de protection régionale disponible) : ARIPO (BW, GH, GM, KE, LR, LS, MW, MZ, NA, RW, SD, SL, SZ, TZ, UG, ZM, ZW), eurasien (AM, AZ, BY, KG, KZ, RU, TJ, TM), européen (AL, AT, BE, BG, CH, CY, CZ, DE, DK, EE, ES, FI, FR, GB, GR, HR, HU, IE, IS, IT, LT, LU, LV, MC, MK, MT, NL, NO, PL, PT, RO, RS, SE, SI, SK, SM, TR), OAPI (BF, BJ, CF, CG, CI, CM, GA, GN, GQ, GW, ML, MR, NE, SN, TD, TG).

Publiée :

— avec rapport de recherche internationale (Art. 21(3))

(54) Title : DEVICE FOR CLOSING BAGS OR THE LIKE, HAVING IMPROVED TACTILE AND SOUND EFFECTS, RESULTANT BAG, AND PRODUCTION METHOD

(54) Titre : DISPOSITIF DE FERMETURE POUR SACHETS OU ÉQUIVALENTS AYANT UN EFFET TACTILE ET SONORE AMÉLIORÉ, SACHET AINSI OBTENU ET PROCÉDÉ DE RÉALISATION

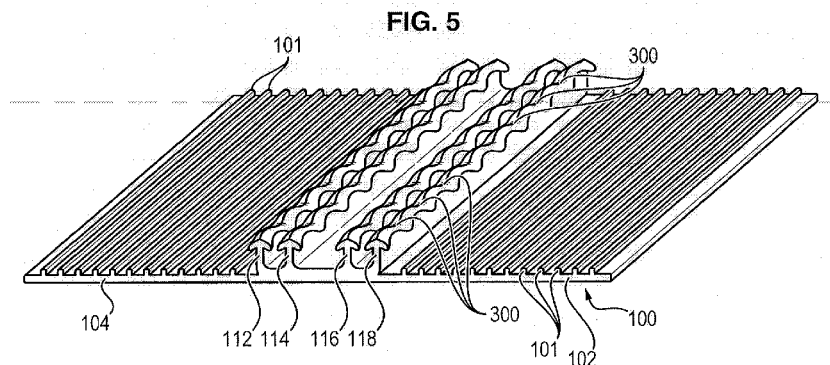

(57) Abstract : The present invention relates to a device for closing bags or the like, including two complementary profile members (A, B), characterized in that each of the two complementary profile members includes at least two profiled attachment elements (112, 114, 116, 118) for which form a multiple closure, in that said profiled elements for attachment have flattened portions (300) distributed over the length thereof, and in that said profiled attachment elements are supported by at least one respective support mat (102, 104) on which said profiled attachment elements are integrally formed, wherein the support mat is to be attached onto a support wall (500) and has a width (14) that is greater than the total width (13) of the profiled attachment elements.

(57) Abrégé : La présente invention concerne un dispositif de fermeture pour sachets ou équivalents comprenant deux profilés complémentaires (A, B), caractérisé par le fait que chacun des deux profilés complémentaires comprend au moins deux éléments profilés d'accrochage (112, 114, 116, 118) formant une fermeture multiple, que ces éléments profilés d'accrochage présentent

[Suite sur la page suivante]



WO 2013/150027 A1

---

un écrasement séquentiel (300) réparti sur leur longueur et que lesdits éléments profilés d'accrochage sont portés par au moins un voile support respectif (102, 104) sur lequel ils sont venus de matière, le voile support étant destiné à être fixé sur une paroi support (500) et ayant une largeur (14) supérieure à la largeur totale (13) des éléments profilés d'accrochage.

DEVICE FOR CLOSING BAGS OR THE LIKE, HAVING IMPROVED  
TACTILE AND SOUND EFFECTS, RESULTANT BAG, AND  
PRODUCTION METHOD

5           The present invention relates to the field of  
closing devices for bags, sacs or the like.

More precisely, the present invention relates to  
closing devices based on two complementary profile  
members 10, 20 carried on respective opposite support  
10 walls 12, 22, as shown by way of non-limiting examples  
in appended Figures 1 and 2.

Numerous variant embodiments of the devices  
illustrated in Figures 1 and 2 have already been  
proposed and fall within the field of the present  
15 invention.

Figure 1 illustrates an exemplary embodiment  
according to which the aforementioned complementary  
profile members are made up of complementary  
male/female members, the male member including a stem  
20 14 integral with the wall 12 and equipped with a  
widened protuberance 15 at its top, while the female  
member 20 consists of a groove 24 with convergent edges  
having in cross-section a cavity complementary to the  
protuberance 15.

25           Figure 2 represents another variant embodiment  
according to which the complementary profile members  
10, 20 consist of hooks 11 and 21.

The general aim of the present invention is to  
propose improvements to such known profile members so  
30 as to generate a tactile sensation and a sound effect  
during closing and opening of the aforementioned  
device, that is respectively during engagement of  
profile members 10, 20 and separation thereof.

Different arrangements have already been proposed  
35 in order to generate such tactile sensations and sound

effects during closing and opening of the  
aforementioned device.

Examples of such known arrangements are described  
in documents WO96/28063, US 5070584, EP 0446760, EP  
5 0510797 and US 5007146. As can be seen in the appended  
Figure 3, the known arrangement usually consist of  
creating a periodic deformation or cutout 30 along one  
of the two profile members, for example the male  
profile member 10 as illustrated in Figure 3, so as to  
10 thus define a succession of hard points and weak points  
in the respective engagement of the members 10, 20.

The means thus proposed do indeed allow the  
generation of a certain tactile and acoustic effect.  
The effects thus obtained thanks to the means hitherto  
15 proposed remain limited, however.

Reference to any prior art in the specification is  
not an acknowledgment or suggestion that this prior art  
forms part of the common general knowledge in any  
jurisdiction or that this prior art could reasonably be  
20 expected to be understood, regarded as relevant, and/or  
combined with other pieces of prior art by a skilled  
person in the art.

In this context, the particular goal of the  
present invention is to improve the known arrangements  
25 of the prior art, so as to reinforce the tactile  
sensation and the sound effect.

#### SUMMARY OF THE INVENTION

30 The above goal is attained within the scope of the  
present invention thanks to a closure device for bags  
or the like including two complementary profile  
members, characterized by the fact that each of the two  
complementary profile members includes at least two  
35 profiled attachment elements forming a multiple

closure, and a support mat configured to be fixed on a support wall of a bag, wherein the attachment elements comprise sequential crushings distributed over their length, wherein each attachment element comprises a stem, wherein outside surfaces of the outermost stems of the attachment elements are separated by a distance, said distance defining a total width of the multiple closure, wherein the support mat comprises a base integral with the attachment elements, and a support web, said support web being integral with the base and extending from one of the outermost stems of the attachment elements, wherein the support web has a width greater than the total width of the respective multiple closure.

15 The Applicant has determined that the very specific triple combination in conformity with the present invention including 1) multiplication of the closure members, 2) sequential crushings and 3) the support mat integrally formed with the attachment elements, generates an improved effect compared with the prior art, thanks to a resonance phenomenon initiated at the attachment elements and propagated in vibratory mode at the support mat, leading to an amplification effect.

25 The present invention also relates to bags or sacks equipped with such a closure device.

The present disclosure also includes a method for making such closure devices or bags including a sequential crushings step.

30 According to other advantageous features of the invention:

- two support mats are provided, integrally formed with the attachment elements, respectively on either side thereof,

- the width of each mat is less than five times the width of the profiled attachment elements,
- preferably, the width of each mat is on the order of twice the width of the profiled attachment elements,
- 5 - the part of the support mat located facing the profiled attachment elements has a convex shape domed outward from the closure,
- the thickness of the support mat facing the profiled attachment elements is greater than the  
10 thickness of the mat on the outside of the profiled attachment elements,
- the closure is implemented in polyethylene or polypropylene,
- the pitch of the sequential crushings is comprised  
15 between 2 and 7.5 mm.

Other features, goals and advantages of the present invention will appear upon reading the detailed description which follows, and with regard to the appended drawings, given by way of non-limiting  
20 examples and wherein:

- Figures 1 and 2, described previously, show a cross-section view of a closure device in conformity with two variant embodiments of the prior art, capable of being used within the scope of the present  
25 invention,
- Figure 3 shows a partial perspective view of a closure device having periodic cutouts conforming to the prior art,
- Figure 4 shows a schematic cross-section view of a  
30 closure device conforming to a first variant embodiment of the present invention,
- Figure 5 shows a partial perspective view of the same closure device, illustrating more precisely the sequential crushings conforming to the present  
35 invention,

- Figure 6 shows a schematic view of the closure device illustrated in Figure 4, in the closed position, that is in the position with the two attachment member assemblies assembled,

5 - Figures 7, 8, 9 and 10 show cross-section view of four variants of closure devices conforming to the present invention,

- Figure 11 shows a plan view of the closure device illustrated in Figure 5 and showing sequential  
10 crushings,

- Figures 12 and 13 show schematically, in a cross-section view of the closure device, two variant embodiments of tools capable of being used for making the closure device conforming to the present invention,

15 - Figures 14 and 15 illustrate schematically a tactile and acoustic effect reinforced thanks to the use of a closure device including a portion of domed support mat facing profiled attachment elements, and

- Figure 16 shows a schematic perspective view of a  
20 bag conforming to the present invention, Figure 16 showing more precisely a partial enlarged view of the multiple closure used for this bag, emphasizing the attachment of the closure, through support mats, to the film of the bag.

25 Shown on appended Figure 4 is a closure device conforming to the present invention, including two complementary members A and B consisting of two parallel support mats 100, 200 respectively bearing one of two complementary profile member assemblies 110,  
30 210.

As previously indicated, each of the two complementary profile member assemblies 110, 210, includes at least two profiled attachment elements forming a multiple closure.



More precisely, according to the non-limiting embodiment illustrated in Figure 4, the two assemblies 110, 210 are symmetrical and each include four profiled attachment elements 112, 114, 116 and 118; 212, 214, 216 and 218. According to this Figure 4, each of the profiled attachment elements 112, 114, 116 and 118; 212, 214, 216 and 218 consists of a profile member with a constant straight section along the entire closure, shaped like an arrowhead. Indeed, each of these profiled attachment elements includes a stem, for example 113, generally orthogonal to a mat 100 or 200 and integral with a mat 100 or 200 provided, at its free end opposite to the mat 100 or 200, with an enlarged head, for example 115. The enlarged head 115 can be symmetrical with respect to the median plane of the stem 113 orthogonal to the mat 100 or 200, or asymmetrical with respect to said median plane. Advantageously, the facets of the enlarged head 115 oriented toward the support mats 100 or 200 converge at least slightly toward the respective support mat, away from the stem 113, so as to form undercuts which reinforce the mutual attachment of the profile members 112, 114, 116 and 118; 212, 214, 216 and 218 provided respectively on the two mats 100 and 200.

More precisely, according to the particular embodiment shown in Figure 4, the 4 profiled attachment elements 112, 114, 116 and 118; 212, 214, 216 and 218 are distributed into two groups of two members 112 and 114 on the one hand, 116 and 118 on the other hand; respectively 212 and 214 on the one hand, 216 and 218 on the other hand. There exists between these two groups (112 and 114 on the one hand, 116 and 118 on the other hand) a gap 11 greater than the gap 12 existing between the two profiled attachment elements (112 and 114) of one and the same group. The first group of

profiled attachment elements 112, 114 integral with a first mat 100 is designed to cooperate, as can be seen in Figure 6, with the first group of profiled attachment elements 212, 214 integral with the second mat 200, while the second group of profiled attachment elements 116, 118 integral with the first mat 100 is designed to cooperate with the second group of profiled attachment elements 216, 218 integral with the second mat 200. To this end, the gap 12 between the two profiled attachment elements (112 and 114 for example) of one and the same group is designed to allow the insertion of an opposite attachment profile member (214 for example), while allowing its subsequent withdrawal, by elastic deformation of the material, if a sufficient pull-out force is applied between the mats 100 and 200.

By way of a non-limiting example, the gap 12 between the two profiled attachment elements (112 and 114 for example) of one and the same group can be on the order of 1 mm, while the gap 11 between the two groups of profiled attachment elements can be on the order of 3 to 4 mm.

The total width 13 or transverse dimension of the profiled attachment elements, corresponding to the distance separating the outside surfaces of the outermost stems, can thus be on the order of 6 mm.

As a variant, the two attachment profile member assemblies 110 and 210 can be asymmetrical.

As indicated previously, within the scope of the present invention the profiled attachment elements are sequentially crushed along the entire closure.

As will be explained in detail hereafter, the crushing of the two complementary profile members 110, 210 generate a series of hard points and weak points during the engagement and the separation of the members A and B of the closure.

The pitch of the crushing is preferably comprised between 2 and 7.5mm, for example on the order of 2.5mm.

In Figure 5, the crushing is shown schematically under reference symbol 300.

5 The making of such sequential crushings will be described later on.

Moreover, as was also previously indicated, according to the present invention, the profiled attachment elements 112, 114, 116 and 118; 212, 214, 10 216 and 218 are carried by support mats 100, 200 formed integrally, the width whereof is greater than the total width 13 of the profiled attachment elements.

More precisely, according to the invention, preferably, two support mat segments 102, 104 and 202, 15 204 are thus provided on either side of the profiled attachment elements and each having a width 14 less than five times the total width 13 of the profiled attachment elements.

More precisely, also preferably, the width 14 of 20 each mat segment 102, 104 and 202, 204 is on the order of twice the width 13 of the profiled attachment elements.

It will also be noted, on examining Figure 4, that preferably the thickness 15 of the support mat facing 25 the profiled attachment elements is greater than the thickness 16 of the mat on the outside of the profiled attachment elements.

The thickness 15 of the support mat facing the profiled attachment elements can thus be on the order 30 of twice the thickness 16 of the mat on the outside of the profiled attachment elements.

The closure can be implemented in any appropriate, preferably polyolefin-based, materials. Advantageously, these are polyethylene or polypropylene.

As indicated earlier, the Applicant has determined that the very specific previously mentioned triple combination conforming to the present invention and including 1) multiplication of the closure members 112, 114, 116 and 118; 212, 214, 216 and 218, 2) sequential crushings 300 and 3) the support mat 100, 200 integrally formed with the attachment elements 112, 114, 116 and 118; 212, 214, 216 and 218, generates an effect that is improved compared to the prior art, thanks to a resonance phenomenon initiated at the attachment elements 112, 114, 116 and 118; 212, 214, 216 and 218 and propagated in vibratory mode at the support mat 100, 200 through the thick base of the mat located facing the attachment elements 112, 114, 116 and 118; 212, 214, 216 and 218, leading to an amplification effect.

The closure conforming to the present invention does indeed allow the generation of a sound effect greater than that obtained with a conventional closure conforming to the prior art.

It will be noted that the profile member sections 102, 104, 202 and 204 located on the outside of the profiled attachment elements can comprise, on their inner surfaces or their outer surfaces, ribs 101, 201 facilitating manipulation of the closure.

The complementary closure profile members 110 and 210 exhibit, prior to sequential crushings, a constant cross-section over their length. They are preferably made by extrusion.

The geometry of the profiled attachment elements 112, 114, 116 and 118; 212, 214, 216 and 218 can be the subject of numerous embodiments.

Certain of these variants are illustrated in the appended Figures 7 to 10.

The embodiment of Figure 7 differs from the embodiment illustrated in Figure 6 in that the outermost profiled attachment elements 112, 118 and 212, 218 are not shaped like arrowheads but rather like  
5 hooks, concave toward the center of the closure.

The embodiment of Figure 8 differs from the embodiment illustrated in Figure 7 in that an additional arrowhead-shaped attachment member 119, 219 is provided in the center of each closure member, so  
10 that each closure member thus includes 5 profiled attachment elements 112, 114, 119, 116 and 118; 212, 214, 219, 216 and 218 evenly distributed in width, the outermost members hook-shaped and the others arrowhead-shaped.

The embodiment of Figure 9 differs from the embodiment illustrated in Figure 4 in that, comparably to Figure 8, an additional arrowhead-shaped attachment member 119, 219 is provided at the center of each closure member, so that each closure member includes 5  
20 arrowhead-shaped profiled attachment elements 112, 114, 119, 116 and 118; 212, 214, 219, 216 and 218, evenly distributed in width.

The embodiment illustrated in Figure 10 differs from the embodiments previous described in that the  
25 part 150 of the support web located facing the profiled attachment elements 112, 114, 116 and 118; 212, 214, 216 and 218 has a domed shape, convex toward the outside of the closure. The domed geometry of the central portion 150 of the support web, convex outward,  
30 is generally accompanied by an adjacent transition portion of the mats themselves 102, 104 and 202, 204, inversely concave outward, as can be seen in Figures 14 and 15. In Figures 14 and 15, the central convex outward domed portion is designated Co, while the  
35 adjacent portions of the concave outward mats are

2013244983 13 Jul 2017

designated Ca. The segments of mats 102, 104 and 202, 204 outside these concave portions Ca are generally flat.

5 This domed geometry of the support mat makes it possible to reinforce the tactile and acoustic effect generated during opening, and to a certain extent during engagement, of the closure. The effect resulting from this crowning is shown schematically in Figures 14 and 15.

10 In these Figures 14 and 15 have been shown the locations of sequential crushings 300 along the base portion 150 of the closure. A person skilled in the art will understand, upon examining Figures 14 and 15, that during an attempted opening, that is separation of the  
15 two closure members A and B, the geometry of the base 150 of the support mat (and this, even for the concave portions Ca of the mats), changes from a domed section over most of the length of the closure and a generally rectilinear section at the last crushed portion 300n of  
20 the profiled attachment elements still engaged. And when this crushed portion 300n, formerly rectilinear and formerly engaged between members A and B, releases under the influence of the pull between the members A and B, the central portion 150 of the closure, located  
25 at the zone 300n, suddenly becomes convex again (conversely, the portions of the mats located at the zone 300n, and which coincide with the otherwise concave portions Ca, suddenly become concave again), while the following crushed portion 300n+1 becomes  
30 rectilinear, and so on over the length of the closure, thus contributing to the tactile and acoustic effect.

According to yet another variant conforming to the present invention, it is possible to combine the different embodiments illustrated in Figures 4 and 7 to  
35 10, in that the member A of the closure can conform to

any one of these embodiments while the other member B of the same closure conforms to another embodiment.

5 Within the scope of the present invention, the closure device including the two closure profile members 110, 210 is made separately from a bag, then applied and bonded, by thermal welding for example, onto the films 500 constituting a bag.

10 The Applicant has observed that the interface thus defined, between the surface of the support mats 100, 200 and the facing surface of the films 500 of the bag, makes it possible to confine the vibrations, generated by the sequential crushings during opening, within the support mats 100, 200 or at the very least to limit the propagation of these vibrations within the films 500, 15 and thus to accentuate the tactile and acoustic effect compared with the prior art.

As previously indicated, within the scope of the present invention, the complementary profile members 110, 210 are sequentially crushed along the entire 20 length of the closure with a crushing pitch comprised between 2 and 7.5 mm, for example on the order of 2.5 mm.

The crushing means can be the subject of various embodiments.

25 Figures 5 and 11 illustrate crushing zones 300 obtained on the peaks of the profiled attachment elements 112, 114, 116 and 118; 212, 214, 216 and 218 and covering the entire width 17 of the profile members, considered perpendicular to their lengthwise 30 direction.

Preferably, the two members A and B are subject to identical crushing with identical pitch.

As shown in Figure 12, the sequential crushing can be accomplished, within the scope of the present 35 invention, separately on each individual member A and B

2013244983 13 Jul 2017

of the closures. Thus what is shown on Figure 12 is crushing of a profiled attachment elements using a ribbed roller 400 with peripheral protrusions 410 having the desired pitch for the sequential crushing 300, pressing on one side of the closure device, preferably on the side of the attachment elements, and a simple backup roller 420, located on the opposite side, that is preferably on the outer face of the support mats. The roller 400 and backup roller 420 are guided or driven in rotation, about respective axes of rotation 402, 422 parallel to one another and to the support mats and perpendicular to the direction of movement of the closure, by any appropriate means.

As a variant, as shown in Figure 13, the sequential crushing can be accomplished within the scope of the present invention, simultaneously on both members A and B of the closure when these members A and B are engaged. Thus what is shown in Figure 13 is the simultaneous crushing of the profiled attachment elements of both members A and B using two ribbed rollers 400, 430 with peripheral protrusions 410, 434 with the pitched desired for the sequential crushing 300, respectively located on either side of the closure. Rollers 400, 430 are guided or driven in rotation, about respective axes of rotation 402, 432, parallel to one another and to the support mats and perpendicular to the direction of movement of the closure, by any appropriate means. This variant of the present invention makes it possible to obtain a considerable periodic deformation of the two complementary profile members 110, 210 while still ensuring their ability to engage and separate, inasmuch as the crushing 300 that is accomplished is perfectly complementary, because it is accomplished with the two profile members in the closed position.



The ribs provided on the rollers for accomplishing crushing are advantageously of a generally domed shape to avoid shearing the material of the crushed profile members, and to avoid removing matter in said profile members during crushing. The ribs provided on the rollers are thus designed to form the crushed portions in the shape of waves with continuously-changing curvature, as seen for example in Figure 5. The Applicant has determined that this arrangement makes it possible to obtain a closure which, in the closed state, has sealing properties with regard to fluids, whether gaseous or liquid, greater than those of closures conforming to the prior art.

Both rollers 400, 430 are preferably synchronized so that their respective protrusions simultaneously press on the profile members 110, 210 to crush them.

It is observed in Figure 11 that the sequential crushings lead to periodic flaring of the attachment elements in width transversely to the lengthwise direction.

When, as illustrated in Figure 13, the sequential crushing is accomplished according to the present invention in the assembled position of the members A and B, it is ensured that the cross-sections of the profiled attachment elements, while distorted in the widening sense, remain perfectly matched, complementary to a certain degree and compatible both for closure, that is for being put into engagement, and opening, that is separation.

It will be noted that the presence of closure segments with constant cross-section between two crushed portions 300, and hence the ease of engagement of these segments between two crushed portions 300 makes it possible, by simply sliding between the fingers of a user, to extend the engagement obtained at

such constant cross-section segments toward the deformed crushed portions 300.

Reinforcement of the tactile sensation and of the sound effect obtained thanks to the present invention results in particular from the transmission of vibrations to the support mats while confining said vibrations within the support mats.

The Applicant has in fact observed that the sound and tactile effect was considerably attenuated when similar sequential crushing was accomplished on closure profile members integrally formed directly on the films 500 constituting the bag.

Within the scope of the present invention, the crushing is preferably carried out so that an enlargement is obtained, in the direction of the width of the profile members, equal to at least 5% of the original width, preferably greater than 10% of said width.

The crushing rollers 400, 430, and the backup roller 420 if any, can be heated in order to reinforce the deformation by crushing of the closure profile members and ensure that they are kept in their sequentially crushed position.

However, if the material allows it, the crushing can be accomplished using simple rollers 400, 430 at ambient temperature.

According to yet another variant, the sequential crushings can be accomplished with rollers at ambient temperature, but operating on a "softened" closure, that is one deformed by hot extrusion, directly after extrusion.

Figure 16 illustrates a bag conforming to the present invention. Seen in Figure 16 is a series of crushed portions distributed over the length of the closure device.

2013244983 13 Jul 2017

Of course, the present invention is not limited to the particular embodiments which have just been described, but extends to any variation conforming to its spirit.

5           The Applicant has also observed that the invention makes it possible to obtain a remarkably fluid-tight closure device compared to the prior art. Besides its previously mentioned features, a good seal is obtained particularly when the height of the crushed portions is  
10 less than the total height of the profile members, and even more precisely when the height of the crushed portions is less than the height of the flared head 115. Indeed, the stem 113 of the profile members is thereby protected. And the assured cooperation between  
15 the crushed heads of the facing profile members put into engagement, combined with the plurality of stems which must be bypassed, in the closed position of a bag, to pass from the inside of a bag to the outside, forms an effective labyrinth constituting an effective  
20 seal with regard to fluids contained in the bags, whether said fluids are gaseous or liquid.

## CLAIMS

The claims defining the invention are as follows:

- 5           1. A closure device for bags including two complementary profile members,  
          wherein each of the two complementary profile members includes at least two profiled attachment elements forming a multiple closure, and a support mat  
10           configured to be fixed on a support wall of a bag,  
          wherein the attachment elements comprise sequential crushings distributed over their length,  
          wherein each attachment element comprises a stem,  
          wherein outside surfaces of the outermost stems of  
15           the attachment elements are separated by a distance, said distance defining a total width of the multiple closure,  
          wherein the support mat comprises a base integral with the attachment elements, and a support web, said  
20           support web being integral with the base and extending from one of the outermost stems of the attachment elements,  
          wherein the support web has a width greater than the total width of the respective multiple closure.
- 25
2. The device according to Claim 1, wherein the support mat comprises two support webs integral with the corresponding base, wherein one of the support webs extends from a first side of the base while the other  
30           of the support webs extends from a second side of the base.
3. The device according to Claim 1, wherein the width of each support web is less than five times the  
35           total width of the corresponding multiple closure.

4. The device according to Claim 1, wherein the width of each support web is twice the total width of the corresponding multiple closure.

5

5. The device according to Claim 1, wherein the base has a domed shape that is convex to the outside of the closure.

10

6. The device according to Claim 5, wherein a portion of each support web located immediately outside the multiple closure and adjacent to the aforementioned convex outward domed base has a shape that is concave to the outside of the closure.

15

7. The device according to Claim 1, wherein a thickness of the base is greater than a thickness of the support web.

20

8. The device according to Claim 1 made of polyethylene or polypropylene.

25

9. The device according to Claim 1, characterized in that a pitch of the sequential crushings is comprised between 2 and 7.5 mm.

30

10. The device according to Claim 1, wherein the complementary profile members each include four attachment elements.

11. The device according to Claim 10, wherein the at least two attachment elements are distributed in groups of two.

12. The device according to Claim 1, wherein the complementary profile members each include five attachment elements.

5 13. The device according to Claim 1, wherein the attachment elements are arrowhead-shaped or hook-shaped.

10 14. The device according to Claim 1, wherein the sequential crushing is accomplished in the form of waves with continuous variation of curvature and over a crushing height less than a height of the profile members and more precisely still preferably over a crushing height less than the height of a flared head.

15

15. Bags or sacks equipped with a closure device according to one of Claims 1 to 14.

**FIG. 1**  
Prior art

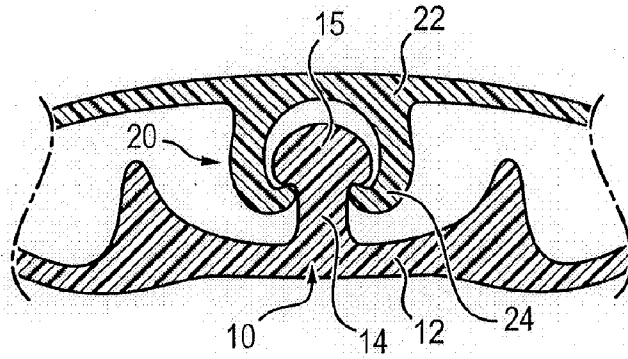

**FIG. 2**  
Prior art

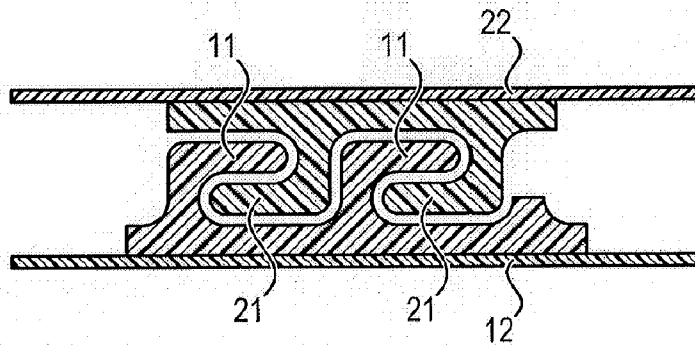

**FIG. 3**  
Prior art

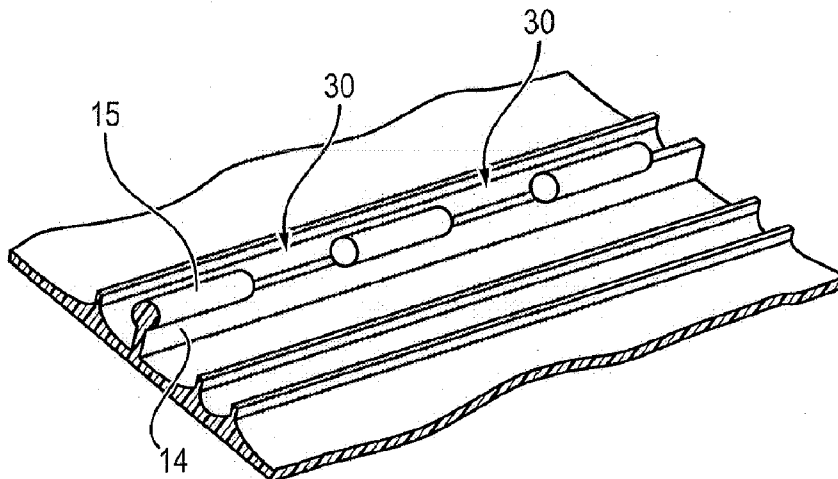

FIG. 4

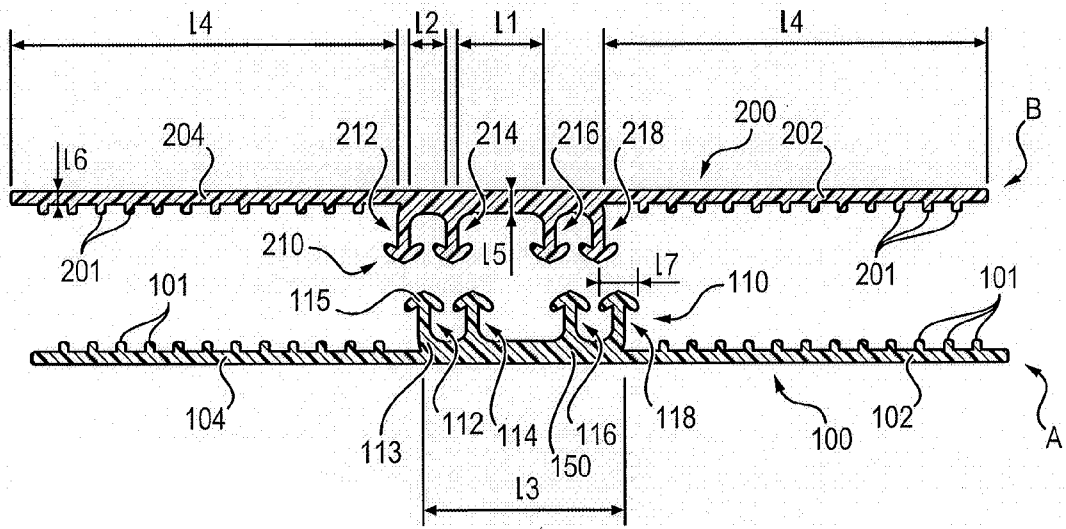

FIG. 5

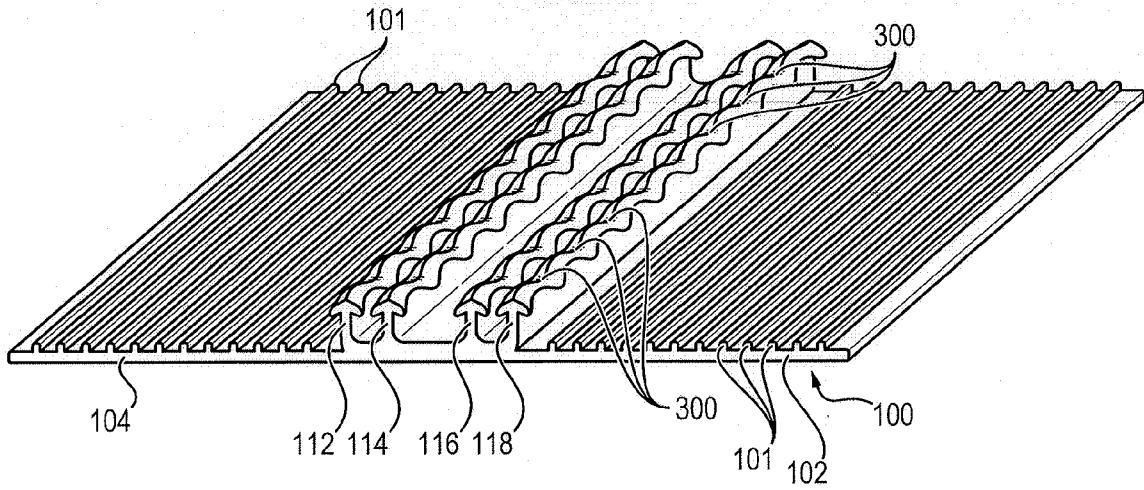



FIG. 6

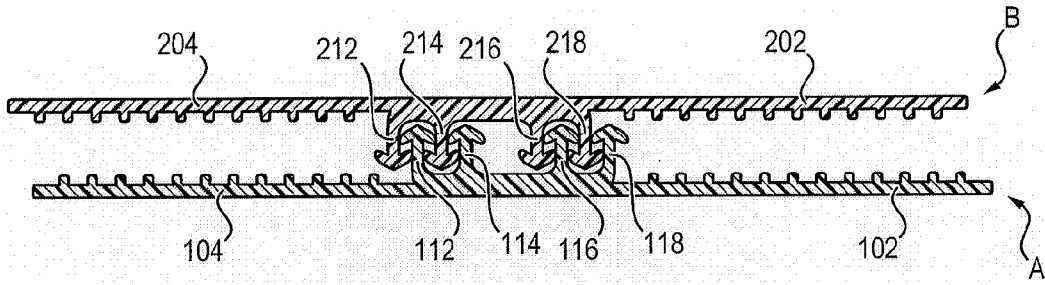

FIG. 7

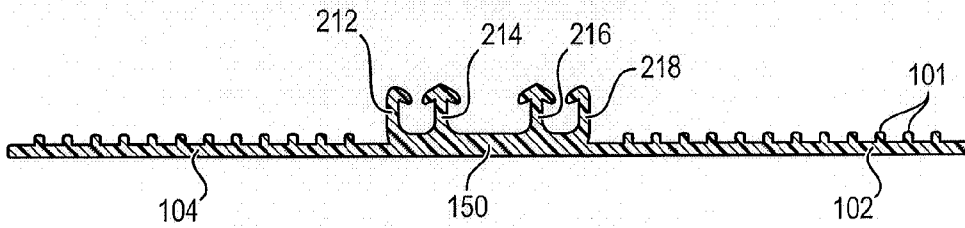

FIG. 8

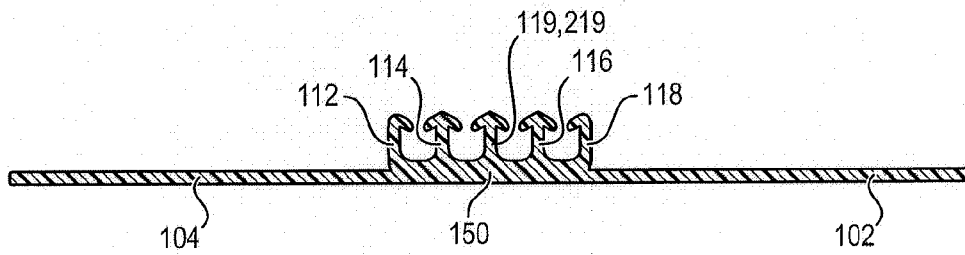

FIG. 9

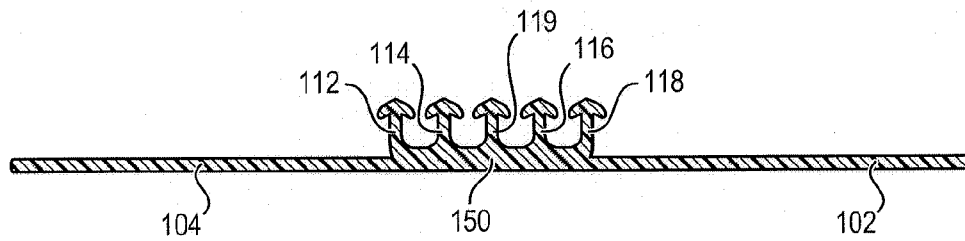

FIG. 10

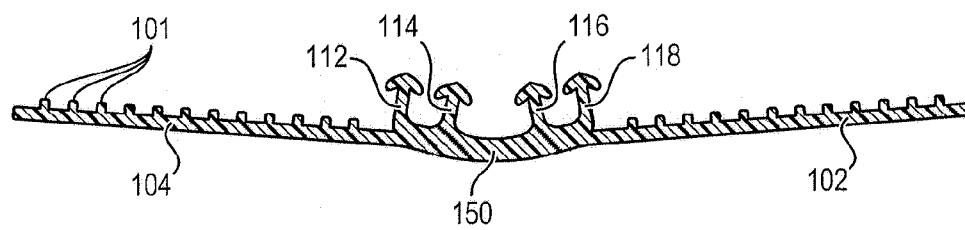

FIG. 11

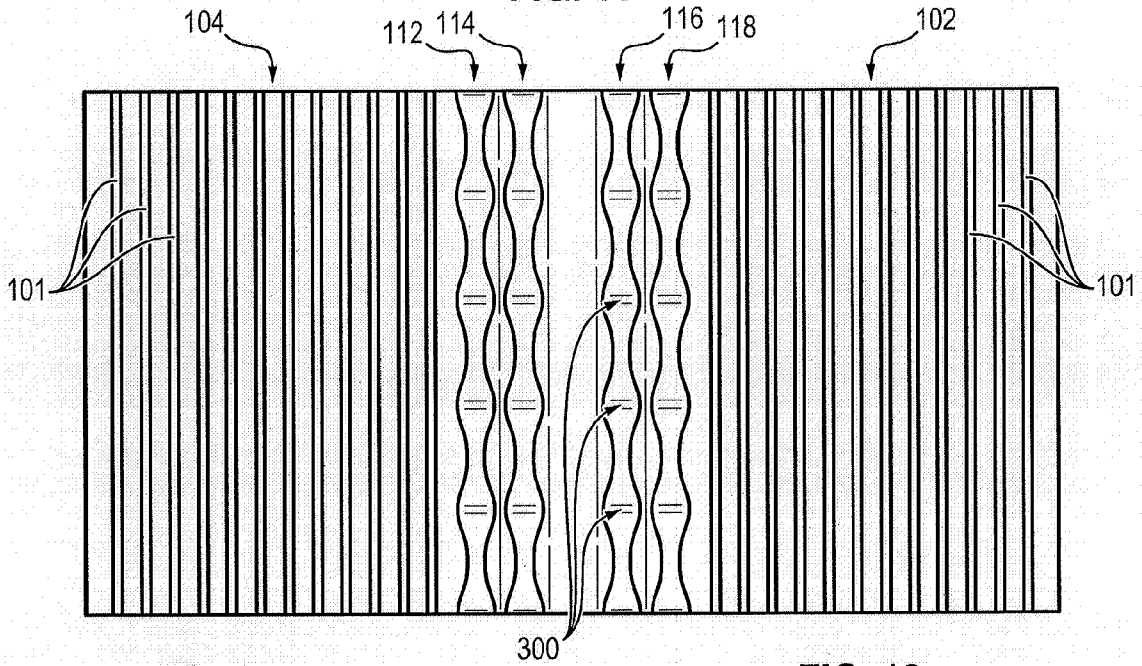

FIG. 12

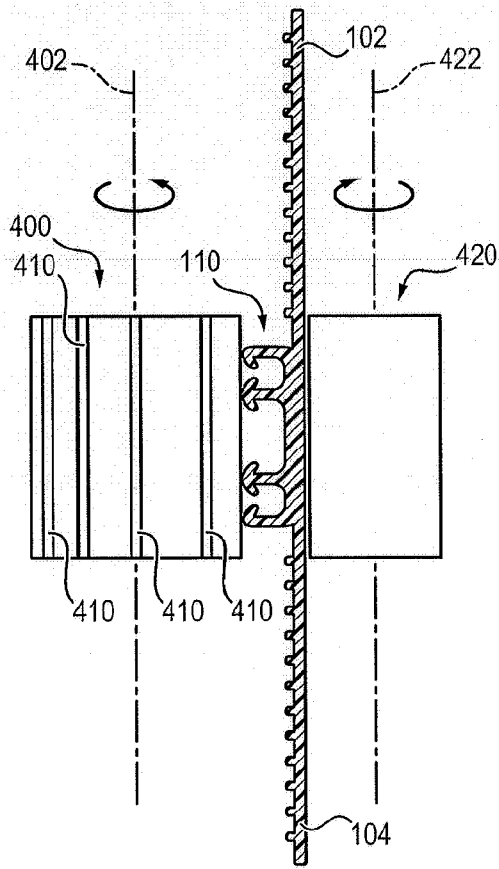

FIG. 13

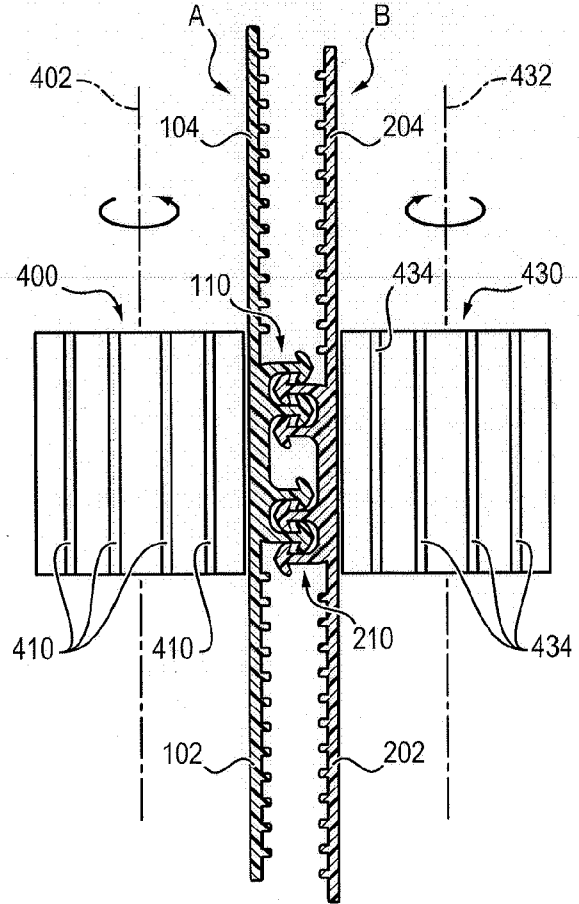

FIG. 14

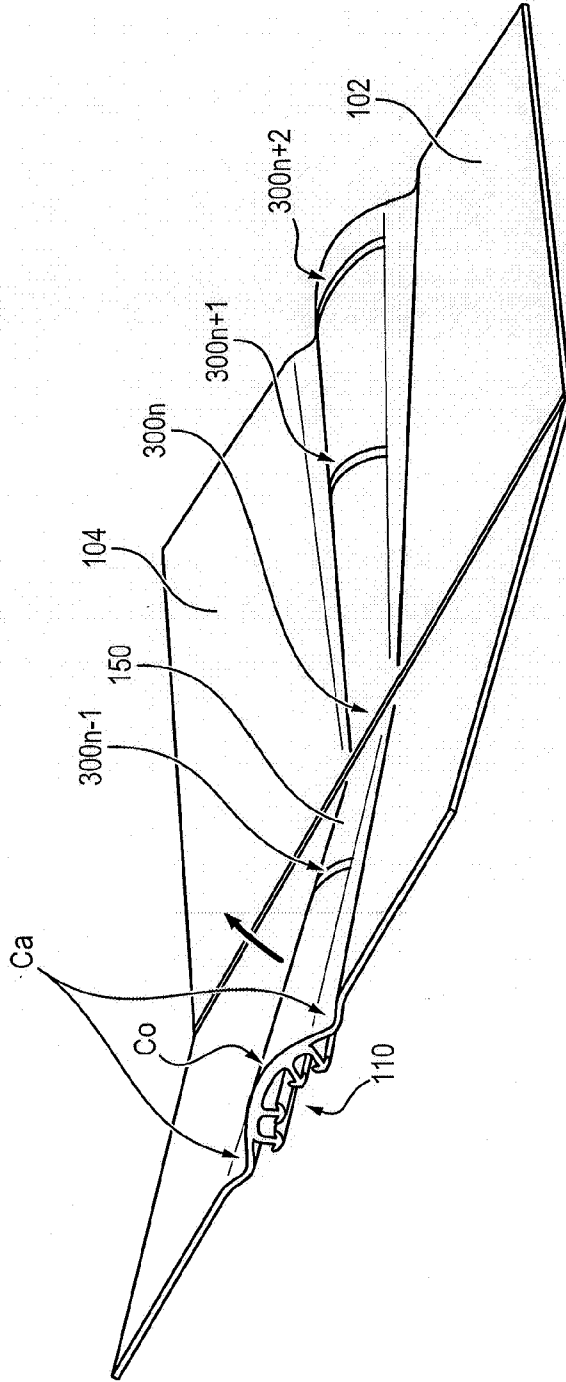

FIG. 15

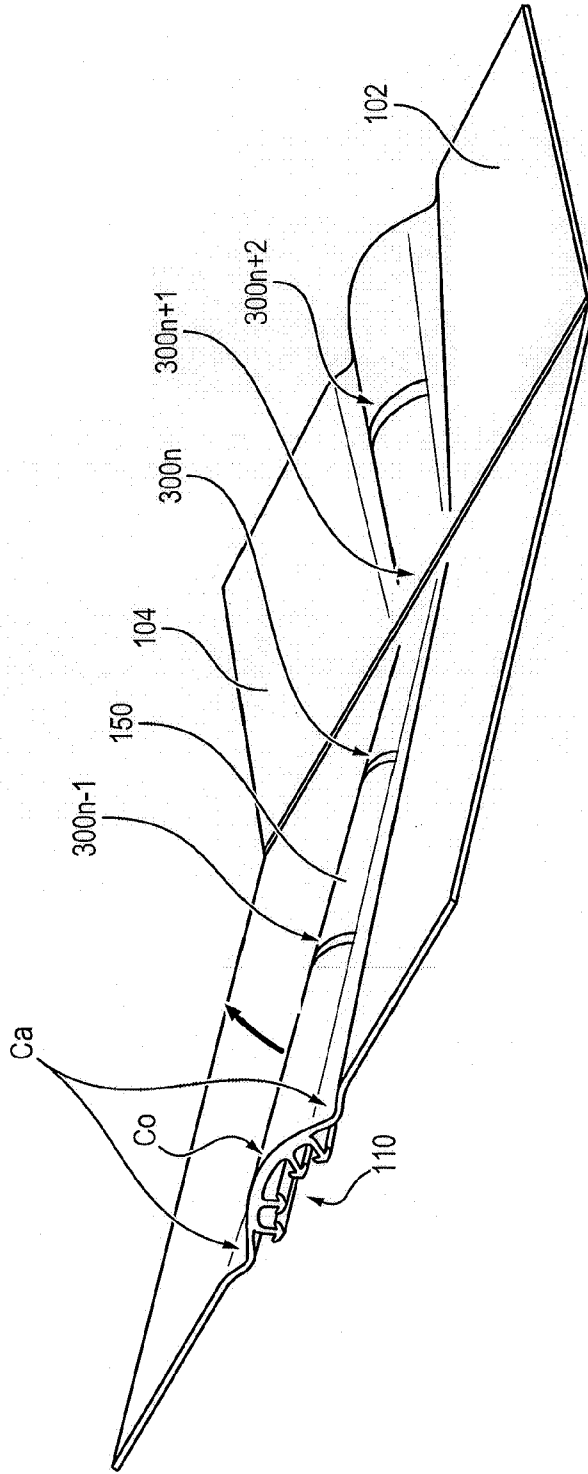

FIG. 16

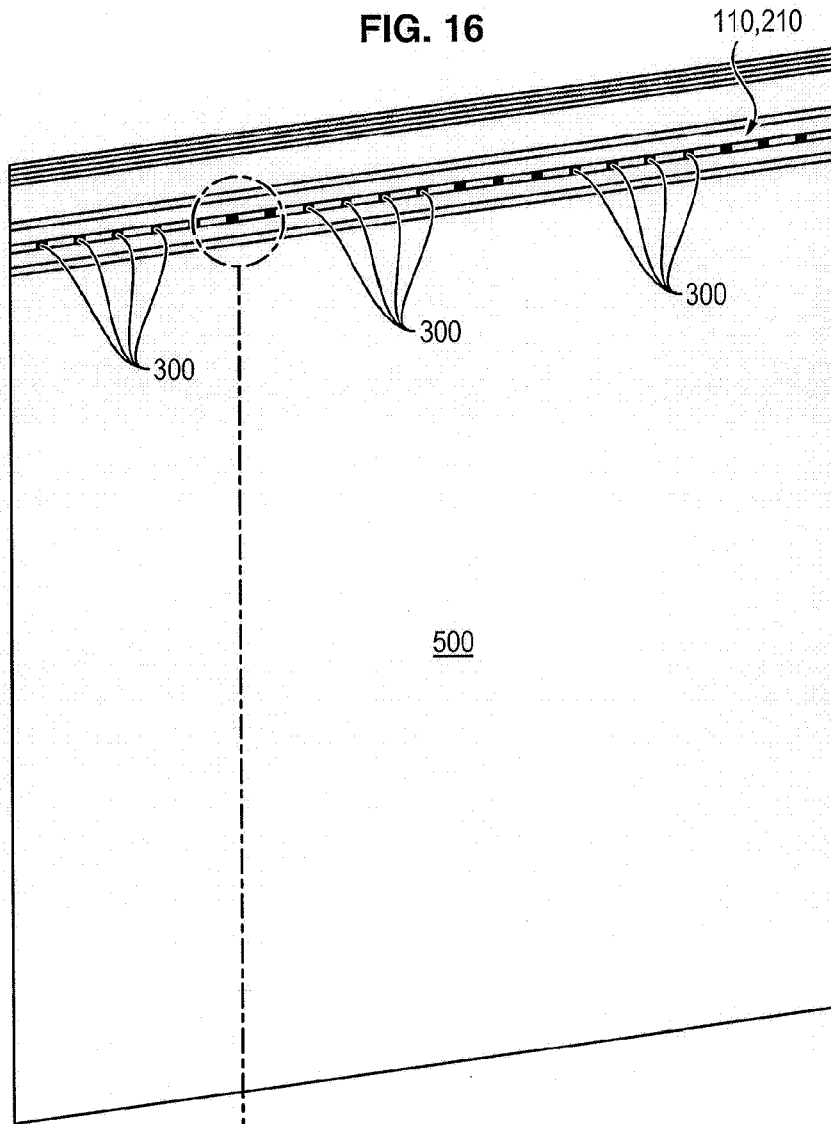

FIG. 16bis

