



(12) **EUROPEAN PATENT APPLICATION**

(43) Date of publication:
08.10.2008 Bulletin 2008/41

(51) Int Cl.:
E02F 5/28 (2006.01)

(21) Application number: **08153180.8**

(22) Date of filing: **21.03.2008**

(84) Designated Contracting States:
AT BE BG CH CY CZ DE DK EE ES FI FR GB GR HR HU IE IS IT LI LT LU LV MC MT NL NO PL PT RO SE SI SK TR
 Designated Extension States:
AL BA MK RS

(71) Applicant: **Schots, Roeland**
3540 Herk-de-Stad (BE)

(72) Inventor: **Schots, Roeland**
3540, Herk-de-Stad (BE)

(74) Representative: **Bird, William Edward**
Bird Goen & Co.
Klein Dalenstratt 42A
3020 Winksele (BE)

(30) Priority: **23.03.2007 BE 200700145**
08.06.2007 BE 200700290

(54) **Device for clearing and/or excavating trenches**

(57) A device for clearing material from a trench comprises a collecting element (110) for storing cleared material (920) in a collecting volume (112). The device furthermore comprises a rotatable element, which is rotatable about an axis and comprises a screw (200) for moving

cleared material. The screw (200) is rotatably arranged about an axis (202) and extends from inside the collecting volume (112) to outside the collecting volume (112) through an opening (120) in the front wall (118). A part of the rotatable element outside the collecting volume (112) protrudes below the bottom side (116).

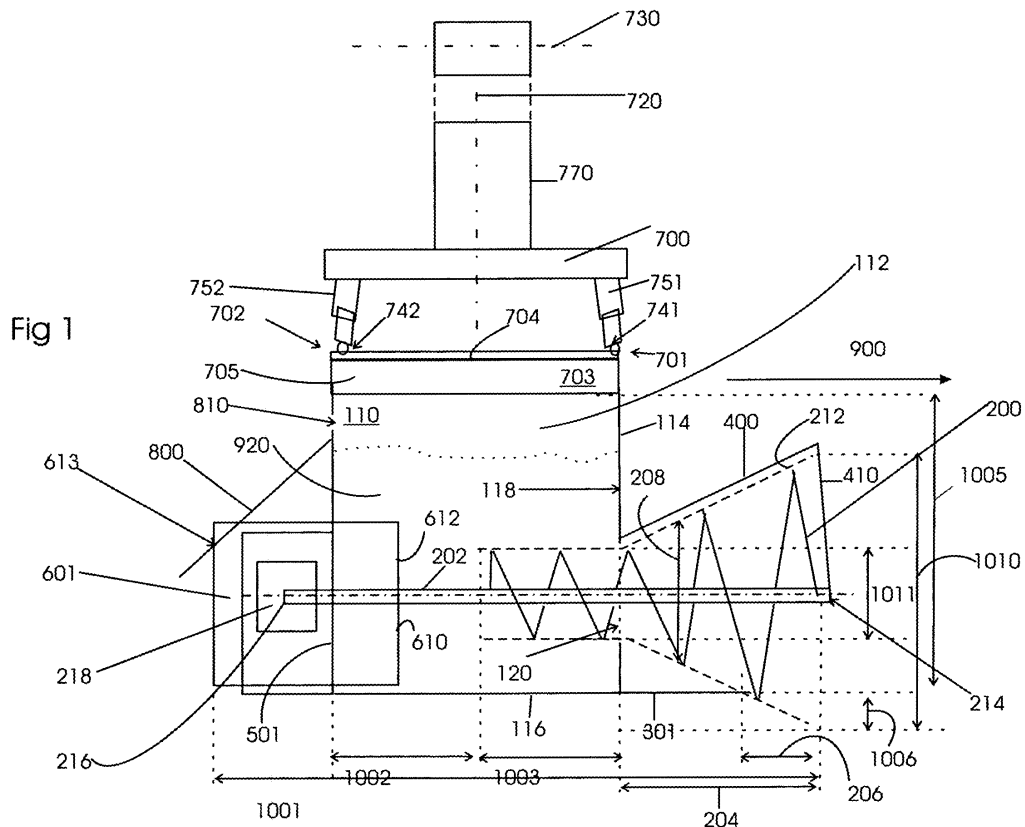

Description

Technical field of the invention

[0001] The present invention relates to a device for clearing and/or excavating trenches.

Background of the invention

[0002] Over time, trenches, for example for draining farmland or running alongside paths, drives, lanes or roads, become polluted and possibly blocked. This is not only caused by litter which ends up in the trenches, but also, and in many cases, by natural products which end up in the trenches, such as branches, leaves, grasses, plants, and by soil or sand which is carried along by water flowing in the trench in the form of mud or sludge, and which slowly builds up sediment on the bottom of the trench and between the grasses and plants which grow on said bottom. After some time, this material forms an obstruction for the water which is supposed to flow through the trench.

[0003] It is known to more or less regularly clear out trenches using excavators. These excavators make with an excavator bucket repeated digging movements in the transverse direction of the trench. This often causes irregularities in the depth of the trench. The bottom of the trench then show pits in which initially again accumulation of sediment and litter will occur. Furthermore, repeatedly clearing out by excavators leads to the trenches becoming wider as, in many cases, a part of the trench wall is also excavated. In addition, careless digging can cause undermining of the trench banks. Finally, in many cases, plants are often completely, i.e. including the roots, removed, from the trench, as a result of which the fauna only slowly recovers.

[0004] An alternative method is disclosed in BE1009679A3. A trench profiling device is provided, having a profiling cutter which comprises, at one end, an open container having a bottom, upright side walls and an upright rear wall, and two rotating cutting elements which are connected thereto and which are rotatably arranged next to one another, opposite the open end of the container, with their bottom side virtually at the height of the bottom of the container. The vegetation on the trench walls is cut by means of the cutting elements, for example rotating knives. The vegetation on the bottom is likewise cut by means of a knife. The cut material is thrown into a receiving unit, together with the material which is in the trench.

Summary of the invention

[0005] According to the present invention, a device is provided for clearing and/or excavating and/or deepening trenches, which device partially or even completely solves the drawbacks which have been experienced hitherto with the known techniques and devices.

[0006] This object is achieved by providing a device for clearing trenches and/or excavating and deepening trenches and a method for clearing and/or excavating and deepening trenches according to the present invention.

[0007] According to the present invention, the device comprises a receiving device, at least one base plate, a means for moving cleared material away from the front of the base plate in a direction opposite to the direction of clearing or excavation, wherein the means for moving cleared material comprises at least one rotatable element, which is rotatably arranged about an axis, the axis being arranged in the direction of movement and making an angle of 0° to 80° to a horizontal plane and wherein a part of the rotatable element extends in front of and below the level of the base plate.

[0008] According to the invention, the rotatable element may comprise a screw.

[0009] Furthermore, at least that part of the screw which is situated above base plate and in front of the base plate may have a diameter which increases in the direction of clearing.

[0010] Furthermore, the front side of the base plate, together with the screw, may form a cutting device.

[0011] The rotatable element may comprise at least one knife.

[0012] Furthermore, the receiving device may comprise a collecting element, in which the means for moving cleared material is arranged such that this means moves the cleared material towards the collecting element.

[0013] The shape of the rotatable element may be adapted to throw the cleared material in the direction of into the collecting element upon rotation.

[0014] The device according to the present invention may also comprise guiding elements for guiding the cleared material thrown up by the rotatable element towards the collecting element.

[0015] The device according to the present invention may also comprise a protective cover which surrounds at least the upper side of that part of the rotatable element which extends in front of the front wall of the collecting element.

[0016] The collecting element may also be provided with at least one, optionally laterally movable, side plate for smoothing an upright trench wall.

[0017] The device according to the present invention may be provided with a suspension means in order to suspend the device from a carrier by means of at least one suspension point, wherein the suspension means comprises an element for varying the orientation of the longitudinal direction (direction of clearing) of the device.

[0018] Said suspension means may also comprise means for rotating the device about a horizontal axis, so that the device can be inclined forwards or backwards.

[0019] The device has the advantage that a trench can be cleared in the longitudinal direction, as the collecting element can move through the trench in the longitudinal direction, for example can slide, over the bottom of the

trench. The device furthermore has the advantage that while it moves through the trench, during which process the screw rotates in order to take material to be cleared, after having been loosened, if required, to the collecting volume in the collecting element, it does not have a tendency to push itself out of the trench in the vertical direction. By means of the rotatable element, for example the screw, which protrudes under the bottom side, the bottom of the trench just in front of the device is loosened up at the bottom of the trench wall. This loosened-up material will either be carried off to the collecting volume by the screw or will flow or spread out along and underneath the wall of the device. If this material on the bottom of the trench had not been loosened up, this material would offer resistance to the device moving through the trench, and would try to stop the movement of the device. This would result in an upward force being exerted on the device.

[0020] The device furthermore allows clearing the trench in one flowing movement between successive culverts, which results in a time saving compared to the discontinuous movements of a prior-art excavator. The use of a device according to an embodiment of the present invention also results in a smoother, more even, straighter and more uniform bottom and trench wall after clearing, which may, in turn, improve the quality of the trench wall and bottom and/or restore them to a desired state. It is possible to produce a trench with a flowing, continuous and sloping line. The clearing operation according to the present invention is also plant-friendly and does not require all vegetation, including roots, to be completely removed from the trench. The fauna and flora of the cleared trenches can thus recover quickly after the clearing, and, thus the shape and dimension of the trench after the clearing will match the desired shape and desired straightness and smoothness of the bottom and walls. In particular, there will only be little damage to the flora which grows on the trench walls as a result of the clearing operation, so that the strength of the trench wall is hardly in any danger, if at all.

[0021] Furthermore, the amount of cleared material can be limited to the amount which is strictly necessary. The shape of the device according to embodiments of the present invention ensures that hardly any soil material is removed from the walls, which is often the case with conventional clearing. This also reduces the costs of the clearing, as conveying and processing cleared material is often an expensive process step, the costs of which are proportional to the volume of cleared material.

[0022] The device according to embodiments of the present invention furthermore has the advantage that relatively large objects which form part of the material to be cleared can be removed more easily and less often lead to blockages in the device. Furthermore, the device according to the invention is robust, requires little maintenance and is little susceptible to damage.

[0023] It will be clear to those skilled in the art that the dimensions of the rotatable element, such as the dimen-

sions of the screw, as well as the dimensions of the collecting element can be adapted to the type of the trench to be cleared and to the dimensions thereof. If desired, more than one rotatable element, which may or may not be identical, for example several screws are placed next to one another in an identical or similar manner. This plurality of rotatable elements may extend through the same or through different openings in the front wall. For at least one of the rotatable elements, a part of this rotatable element protrudes outside the collecting volume under the bottom side. In a similar manner, it is possible to clear relatively wide and/or deep trenches using a plurality of rotatable elements. At least one, but also several or even all, of this plurality of rotatable elements may comprise a screw which protrudes under the bottom side.

[0024] According to one embodiment, at least that part of the screw outside the collecting volume which protrudes under the bottom side may be provided with knives, for example on that part of the screw which projects furthest in front of the front wall. These knives, which form part of the screw, may be provided at the largest diameter of the screw, so that they do not loosen up the material to be cleared and enable this loosened-up material to be moved by the rotary movement of the screw. It is even sufficient for the knives, which form part of the screw and which are provided at the largest diameter of the screw, to protrude under the bottom side.

[0025] In some embodiments of the device, the axis of the rotatable element, that is the axis of the screw, may make an angle greater than 0° with the longitudinal direction. The axis makes an angle with the longitudinal direction between 0° and 80° , for example between 0° and 60° , such as between 0° and 45° , or even between 0° and 20° or between 0° and 10° .

[0026] In this embodiment, the axis of the rotatable element and the longitudinal direction therefore do not run parallel. The angle is preferably between 1° and 10° . The angle may, if desired, be adjustable, so that the angle and the length by which the rotatable element protrudes under the bottom side can be adapted to the requirements and to the type of trench which is to be cleared.

[0027] According to some embodiments, along part of the axis of the screw outside the collecting volume, the diameter of the screw may increase along the axis in a direction from the front wall to the end of the screw which projects in front of the front wall.

[0028] A part of the screw which projects in front of the front wall may, for example, have a conical profile, i.e. a screw in which the diameter of the screw increases along the axis of the screw in a well-defined direction from one point along the axis to another point along the axis. The diameter of the screw is twice the perpendicular distance of the axis to the furthest point of the screw at this point of the axis.

[0029] According to an alternative embodiment, at least that part of the screw which projects in front of the front wall may have a profile in which the screw diameter increases in a stepped manner in the direction of clearing,

for example from the front wall of the collecting element in the direction of clearing.

[0030] The screw may be built into the device, with an axis, that is the axis of the rotatable element, extending parallel to the longitudinal direction, which facilitates construction, while the screw, due to the increasing diameter, can still protrude under the bottom side of the wall.

[0031] The device according to the invention may comprise a means in order to vary or adjust the angle between the axis and the longitudinal direction. The device may also comprise a means to vary or adjust the distance between the rotatable element and the front wall of the collecting element. Furthermore, the device may comprise a means to vary or adjust the length by which a part of the rotatable element, which is in front of the collecting element, protrudes under the bottom side upon rotation about the axis in at least one rotary position.

[0032] According to an alternative embodiment, the rotating element consists of one or more knives and the device comprises a rotatable screw which is arranged partly or completely independently from the rotating element and which works partly or completely independently. If desired, the operation of the rotatable screw and the operation of the rotatable element may be adapted to one another, for example may be synchronized.

[0033] Alternatively, the device may also comprise a conveyor belt. Cleared material which is transferred to the conveyor belt by the rotatable element can be conveyed further in the direction of the collecting element by the conveyor belt, for example as far as into the collecting volume.

[0034] According to some embodiments, the device may furthermore comprise at least one base plate which extends in front of the front wall of the collecting element and which, preferably, is in line with the bottom side of the collecting element, which base plate, together with the screw, forms a cutting device.

[0035] The cross section of the base plate and the bottom side of the collecting element is preferably curved, partly adapted to the cross-sectional profile of the trench.

[0036] The base plate and the outer circumference of the screw perform a scissor movement with respect to one another. Grasses or objects which end up between these two parts are cut. The base plate closely adjoins a portion of the circumference of the screw.

[0037] Material which is stuck in the bottom of the trench, for example grasses or plants, is cut and can thus be cleared. However, such grasses are not pulled out, so that, after clearing has taken place, the grasses can grow again and can reinforce the bottom and partly also the walls of the trench.

[0038] According to some embodiments of the device, the rotatable element may be designed to throw the cleared material in the direction of into the collecting element upon rotation.

[0039] According to some embodiments, the shape and orientation of the rotatable element, for example one or more knives or cutter knives, may be chosen such that

loosened-up material on the bottom of the trench, and also material which is cut during the clearing operation, is thrown backwards to the collecting element by rotation of the rotatable element, if desired even through an opening in the front wall of the collecting element, or over a rim of the collecting element, as far as into a collecting volume. The rotatable element, upon rotation, transfers a force onto the cleared material which ensures that the cleared material is propelled towards the collecting element, if desired in the direction of and through the opening in the front wall of the collecting element. The shape of the rotatable element and the direction of the rotation axis of the rotatable element ensure that the force which is exerted on the cleared material is directed towards and in the direction of the collecting element. Thus, it is advantageous to have a rotation axis which is at an angle to the longitudinal direction of the device of between 0° and 80°, preferably between 0° and 60°, such as between 0° and 45°, or even between 0° and 20° or between 0° and 10°. The rotation axis of the rotatable element may be tilted sideways and/or backwards or may be arranged so as to be tiltable. The sideward and/or backward tilting of the rotation axis is advantageous. The axis may be tilted only sideways or only backwards, or both sideways and backwards.

[0040] The rotatable element, in specific embodiments one or more knives, for example cutter knives, may have a shape which is designed to cause or amplify a backward throwing movement.

[0041] The one or more knives or cutter knives may be fitted on a holder, for example a disc-shaped holder, which is coupled to the axis. The device may be provided with means to facilitate installation of the rotatable elements on the axis and removal of the rotatable elements therefrom. This has the advantage that rotatable elements can be quickly replaced or exchanged in case of an unplanned or planned service. This also has the advantage that rotatable elements can easily be adapted to the desired shape of the trenches to be cleared by fitting a rotatable element, the dimensions of which are adapted to the desired trench profile.

[0042] The device offers the advantage that when various trenches of different dimensions, for example different widths, have to be cleared, the device can easily be adapted by mounting a disc (provided with one or more knives or cutter knives), the dimensions of which disc are adapted to the specific dimensions of the trench. The orientation of the rotation axis of the rotatable element can also be used to adapt the shape of the rotatable element to the shape of the trench. By turning the axis to one of the sides, the width of the volume which is cleared will be reduced. By turning the axis upwards or downwards, the shape of the bottom of the trench will change from a more circular shape to an elliptical shape.

[0043] The cleared material which is thrown backwards may be thrown directly into the collecting volume of the collecting element or may be thrown onto a conveying mechanism which furthermore comprises a con-

veyor belt and/or a rotatable screw. Cleared material which is passed onto the conveying mechanism, for example the conveyor belt or screw, by the rotatable element, may be taken further by the conveying mechanism, for example the conveyor belt or screw, in the direction of the collecting element, for example as far as into the collecting volume. In order to achieve further distribution of cleared material in the collecting volume of the collecting element, a distributing unit, for example an additional screw, may furthermore be provided in the collecting volume.

[0044] According to some embodiments, the device may comprise a protective cover which surrounds the upper side of that part of the screw which extends in front of the front wall, and preferably the entire part of the rotatable element which extends in front of the front wall.

[0045] The device comprising a rotatable element which is designed to throw the cleared material in the direction of or into the collecting element upon rotation, may furthermore be provided with one or more guiding elements in order to guide the thrown material in the direction of the collecting element or, if desired, the conveying mechanism, for example a screw or a conveyor belt. The guiding elements may form a protective cover which also surrounds and protects at least this part of the rotatable element against undesirable contact with, for example limbs or overhanging branches from trees.

[0046] The material which is loosened up by means of the rotatable element and is taken further to the collecting volume of the collecting element, is prevented from escaping by the guiding element or the guiding elements.

[0047] The protective cover also increases the suction power of the screw.

[0048] According to some embodiments, the device may furthermore comprise a supporting arm which connects the first end of the axis of the rotatable element, which first end is situated in front of the front wall of the collecting element, to the collecting element.

[0049] At this end, the axis of the rotatable element is supported so that the permanent positioning of the axis in the collecting element can be ensured more easily.

[0050] According to some embodiments, the device may furthermore comprise a motor which is coupled to the second end of the axis.

[0051] At the front side of the entire system, the device has no components which could prevent easy movement of the device through the trench in the longitudinal direction.

[0052] The motor may be situated outside the collecting volume. As a result, the device has fewer problems coping with the soiling effect that the cleared material and sludge have on the motor.

[0053] According to some embodiments, at least one, optionally laterally movable, side plate may be coupled to the outer wall for smoothing an upright trench wall, which side plate is preferably attached to the outer wall on the front side in the longitudinal direction.

[0054] On the rear side, the side plate or the side plates

may, if desired, be positioned at a distance from the side wall, so that at least the rear side of the plate pushes against the trench wall when the device is moved through the trench in the longitudinal direction. Loosened material, which could flow past the device, is in this manner pushed against the trench wall, where it can, in time, reinforce the trench wall. If desired, the side plate is hingedly secured to the outer wall, to the front side in the longitudinal direction, and means are provided in order to adjust or vary the distance between the outer wall and side plate on the rear side of the side plate. It is, for example, possible to use adjustable springs to adjust the force between the side plate and trench wall. Alternatively, hydraulic plungers may be provided.

[0055] According to some embodiments, the device may have a suspension means in order to suspend the device from a carrier by means of at least one suspension point, in which the suspension means comprises an element for varying the orientation of the longitudinal direction.

[0056] This may be achieved by providing a frame, for example a rigid construction, to which the collecting element can be fastened. Two hydraulic plungers may, for example, be mounted on the frame, one on the side of the frame which is directed towards the front wall, and one on the side of the frame which is directed towards the rear wall. By actuating the plungers, the front or rear side of the device can be moved up or down, as a result of which the inclination of the longitudinal direction changes.

[0057] When the device is suspended from a vehicle, the longitudinal direction of the device can be adjusted independently from the orientation of the vehicle, so that the device is able to follow the profile of the trench bottom more accurately during clearing.

[0058] According to a further aspect of the present invention, a method for clearing a trench is provided. The method comprises:

- providing a device according to the first aspect of the present invention;
- lowering the device into the trench to be cleared;
- moving the device through the trench in longitudinal direction while rotating the element about its axis for collecting cleared material in the collecting volume;
- raising the device from the trench;
- removing the cleared material from the collecting volume of the device.

[0059] The advantage of the method is that it is a continuous, and therefore time-saving clearing movement, which allows the bottom and the side walls of the trenches to be smoothed again in a satisfactory manner. The bottom and side walls no longer have any discontinuities which were caused by successive excavating movements. In addition, grasses and plants on the bottom and along the side walls of the trenches are cut and not pulled out, so that the cleared trenches will soon be covered by

vegetation again. The ecological balance of the trench is not affected as much as it is with certain prior-art clearing methods and can recover quickly.

[0060] According to some embodiments of the method according to the present invention, the device can be suspended from a vehicle. The removal of the cleared material from the collecting volume of the device is effected by pouring out the cleared material into a receptacle intended for the purpose, for example into a high-walled container which is moved by the vehicle from which the device is suspended.

[0061] According to some embodiments of the method according to the present invention, the cleared material can furthermore be discharged into a settling container for separating sludge and water.

[0062] According to some embodiments of the method according to the present invention, the settling container may be a substantially rectangular container having a bottom, a front wall, a rear wall and a first and second side wall, which together form a watertight volume. On the upper side, the rear wall may be provided with an opening for allowing water to flow out.

[0063] According to some embodiments of the method according to the present invention, the settling container may be arranged in an inclined position so that the front wall is in a higher position than the rear wall.

[0064] During settling, the excess water can be removed via the opening which, for example, can be connected to a line for discharging the water, for example to a collecting tank or back into the trench.

[0065] According to some embodiments of the method according to the present invention, the settling container may furthermore be provided with at least one dividing wall, positioned between the front wall and the rear wall, an upper side of the dividing wall being provided with an opening for allowing water to flow out.

[0066] The openings may be provided with movable, for example rotatable, shutters, which makes it possible to open or close the openings. In the closed position, water is prevented from flowing through the openings to the adjacent compartment or outside the container.

[0067] The rear wall of the container may be provided with a chamber for collecting the water which flows from the opening in the rear wall. The chamber has an opening. The chamber is provided with a passage or passage opening for discharging the water collected in the chamber to outside the chamber. The passage of this chamber may have a connection for connecting discharge lines, for example a suitable rapid coupling.

[0068] According to some embodiments of the method, water which is separated from sludge and cleared material in the settling container can be discharged by placing the settling container at an angle. In this case, the water is allowed to flow through the opening in the rear wall to the chamber. To this end, the shutters are opened partially or completely. This water in the chamber may then be returned to the trench via the passage and, if desired, via a pipe system. Alternatively, the chamber

is connected to a vacuum chamber via the passage, for example of a cess pit or cess pool, and the water is sucked out by means of suitable suction lines connected to the connection. The chamber may, if desired, be provided with safety valves. If the container has to be lifted, for example hoisted onto a trailer in order to be moved, the shutters are preferably closed. This prevents water from flowing through the openings while the container is at an angle of inclination during lifting, which is sufficiently large to bring the water up to the openings.

[0069] The settling containers are preferably placed on a site where they are filled. Once filled, they are lifted onto a trailer, as a result of which one side, for example the front side, of the container is raised. As the cleared material often is highly liquid, the cleared material then runs against the relatively opposite side, which is for example the rear side. In order to prevent the cleared material from flowing over the rear wall, the container therefore has a maximum filling level and/or maximum angles of inclination of the bottom and base area, above which the container should or must not be lifted. As the angle between the bottom of the settling container and base area is determined by the dimensions of the container and trailer, the filling level of the container is limited. By providing a dividing wall, the maximum angle of inclination can be increased, or alternatively, the container can, at certain angles, be filled to a higher level, without this resulting in the cleared material overflowing while lifting the container onto the trailer. Furthermore, the dividing wall and/or the rear wall may be provided with an additional protective plate or upright wall, which protrudes above the container volume. This further prevents water from flowing over the dividing wall or rear wall while the container is inclined, for example while the container is being hoisted onto a trailer.

[0070] The invention makes it possible to carry out the clearing with a relatively low energy consumption and thus only requires relatively little power from, for example, the vehicle to which the device is coupled, compared to the prior-art systems which use reduced pressure or suction systems to move cleared material.

[0071] The device according to the invention may be designed and used for clearing trenches, which trenches are situated either on the left-hand side or on the right-hand side of the vehicle. If desired, provisions may be made to make it possible to clear trenches on both sides of the vehicle. Thus, for example, the directions of rotation of the axes and motors may be adjustable, that is to say may be clockwise or counterclockwise, as desired by the operator.

[0072] The device according to the invention is also suitable for excavating or deepening trenches in which the material which is released in the process can be removed in a simple manner.

[0073] Separate and preferred aspects of the invention are defined in the attached independent and dependent claims. Features of the dependent claims may be suitably combined with the features of the independent claims

and with the features of other dependent claims, and not only in the manner as explicitly defined in the claims.

[0074] The reference numerals as used below refer to the attached drawings. Other features, characteristics and advantages of the present invention will become clear from the following detailed description in combination with the attached figures which illustrate the principles of the invention by way of example.

Short description of the figures

[0075]

Fig. 1 schematically shows a cross-section along a longitudinal direction of the device according to a first embodiment of the invention.

Fig. 2 shows a diagrammatic front view of the device from Fig. 1.

Fig. 3 shows a diagrammatic top view of the device from Fig. 1.

Fig. 4 schematically shows a cross-section along a longitudinal direction of a device according to a second embodiment of the invention.

Fig. 5 shows a diagrammatic front view of the device from Fig. 4.

Fig. 6 shows a diagrammatic top view of the device from Fig. 4.

Fig. 7 schematically shows a cross-section along a longitudinal direction of a third embodiment of the invention.

Fig. 8 shows a diagrammatic front view of the device from Fig. 7.

Fig. 9 shows a diagrammatic top view of the device from Fig. 7.

Fig. 10 schematically shows the use of a device according to the invention for clearing a trench.

Fig. 11 schematically shows how the cleared material is transferred to a settling container and how water can be removed from such a container.

Fig. 12 shows details of a settling container which can be used with the method illustrated in Fig. 11.

[0076] In the figures, identical or similar elements are denoted by the same reference numerals.

Description of illustrative embodiments

[0077] The present invention will be described by means of certain embodiments and with reference to certain drawings. However, the invention is not limited to the illustrated embodiments. The drawings and figures are only diagrammatic and do not limit the invention to the elements which are illustrated. In the drawings and figures, the dimensions of some elements may have been increased and not been drawn to scale for illustrative purposes. The dimensions and relative dimensions do not necessarily correspond to the actual dimensions of physical embodiments.

[0078] Furthermore, the terms first, second, third and similar terms are only used to distinguish between various identical elements and these terms do not necessarily denote a specific sequence, neither in time, nor in space, order or of any other kind. It will be clear that, under suitable circumstances, the terms are interchangeable and that the embodiments of the invention described herein can operate in a sequence which is different from that described or illustrated in the present application.

[0079] It should be noted that the terms "contain" and "comprise" should not be interpreted as being limited to the elements, parts, components or the like which are mentioned thereafter. This term does not exclude further steps, elements, parts, components or the like. It indicates the presence of elements, parts, components or the like, but does not exclude the presence of one or more elements, parts, components or the like, or groups of elements, parts, components or the like. Thus, the scope of the expression "a device comprising A and B" is not limited to a device which only consists of A and B. It means that in the context of the present invention, the components or elements of the device which are relevant to the invention are A and B.

[0080] A reference to "one" or "an" embodiment means that specific features, characteristics or structures described in relation to that embodiment are at least incorporated into at least one embodiment according to the invention. Therefore, references to "in an embodiment" or "in one embodiment" in various parts of the description do not necessarily refer to the same embodiment, although they may indeed refer to the same embodiment. Furthermore, the specific features, characteristics or structures can be combined in one or more embodiments, as will be clear to those skilled in the art.

[0081] In a similar manner, it should be understood, that with the embodiments which are described by way of example in the description, different features of the invention are sometimes grouped together in one embodiment, figure or part of the description so as to provide a clear description in order to explain the various features of the invention. However, this does not mean that the invention would comprise more features than the way in which the invention is defined in the claims. Instead, as will be clear from the following claims, the inventiveness of the invention is based on fewer than all features of one single above-described embodiment. Thus, the claims following the description are expressly incorporated in the detailed description of the invention, with each of the claims in itself forming a separate embodiment of the invention.

[0082] Furthermore, although some embodiments which are described here comprise certain features and do not comprise others, combinations of features of the various embodiments are intended to be within the scope of the invention, as will be understood by those persons skilled in the art. For example, all the following embodiments may be combined in all kinds of possible combinations.

[0083] Furthermore, each element of an embodiment of an object or device should be interpreted as an example of a means for carrying out a specific function, which function is achieved by the use of the element with the object of realizing the invention.

[0084] The attached description describes and illustrates many details. However, it will be clear that the invention can be realized without these specific details. In other cases, well-known methods, structures, elements and the like are not shown in order not to complicate the description unnecessarily in the light of the invention.

[0085] The following terms and definitions are only intended as an aid to understand the invention.

[0086] The term "cleared material" or the term "material", in connection with the clearing thereof, comprises all materials, in addition to the normal liquids which are discharged by the trench or which may be present in a trench and which may possibly form an obstruction with regard to draining the trench. It comprises in particular water, oil, sand, mud, sludge, leaves, branches and twigs, litter (for example cans, cigarette butts, packaging, paper, plastic and all kinds of other objects), as well as vegetation such as grass, moss, weeds, bushes and the like. When the invention is used for excavating or deepening a trench, then the term "cleared material" or the term "material" means all materials which have to be removed when excavating or deepening the trench.

[0087] The term "screw" is understood to mean an object which is able, through rotation about its axis, to displace a liquid or liquid-like substance or another displaceable material in the direction of the axis, such as an Archimedean screw or screw pump.

[0088] The term "pump" is understood to mean displacing a liquid or liquid-like substance or another displaceable material by means of rotation of a screw about its axis and in the direction of the axis.

[0089] The term "longitudinal direction" is the direction between the front side and the rear side of the collecting element of the device, and is essentially parallel to the bottom side of the collecting element.

[0090] The term "direction of clearing" is the direction in which the clearing device according to the present invention moves or is moved during clearing; this direction is virtually parallel to the longitudinal direction in the sense that it runs from the rear wall to the front wall.

[0091] The invention will now be described by means of a detailed description of various embodiments of the invention. It will be clear that other embodiments may be configured in accordance with the knowledge of the person skilled in the art without departing from the technical contribution according to the spirit of the invention. The invention is solely limited by the wording of the attached claims.

[0092] A device for clearing material from trenches according to a first embodiment of the invention is illustrated in Figures 1, 2 and 3. The device comprises a receiving device, in this embodiment a collecting element 110 for storing cleared material 920 in a collecting volume 112.

The collecting element 110 is provided with an outer wall 114 which delimits the collecting volume 112 of the collecting element. The outer wall 114 is designed to move through a trench in the longitudinal direction 900. To this end, the outer wall 114 may, for example, have specific material properties, such as for example smoothness. The outer wall 114 provides the collecting element at least with a bottom side 116 and comprises a front wall 118. The device as illustrated in Fig. 1 furthermore comprises a rotatable element which, in this embodiment, is a screw 200 for displacing cleared material 920. This screw 200 is rotatable about an axis 202, which is thus also the axis of the rotatable element. The screw 200 extends from inside the collecting volume 112 to outside the collecting volume 112 through an opening 120 in the front wall 118. A part of the screw 200, denoted by reference numeral 204 in longitudinal direction 900, is outside the collecting volume in front of the front wall 118. A part of the screw 200 (denoted by reference numeral 206 in the longitudinal direction 900) protrudes below the bottom side 116, preferably for a distance of 5 cm to 200 cm in the longitudinal direction 900. A part of the screw 200 (the part denoted by reference numeral 1006 in a direction at right angles to the longitudinal direction 900, i.e. the vertical direction) protrudes below the bottom side 116, preferably over a distance of 1 cm to 50 cm in the vertical direction.

[0093] The opening 120 in the front wall 118 and the diameter of the screw 200 at the opening 120 are tuned to each other, so that the screw 200 can rotate about its axis 202 in the opening 120.

[0094] Along at least a part of the axis 202 of the screw 200 outside the collecting volume 112, which in this example coincides with the part of the screw denoted by reference numeral 204, i.e. the part which extends in front of the front wall 118 in the longitudinal direction 900, the diameter 208 of the screw 200 increases in a direction away from the front wall 118. The direction of increasing diameter is the direction of clearing, or in other words: a direction away from the front wall 118, from the front wall 118 to the end 214 of the part of the screw 200 which extends in front of the front wall 118.

[0095] The part of the screw 200 that extends in front of the front wall 118, in the present embodiment denoted by reference numeral 204, may thus have a conical profile 212.

[0096] The device furthermore comprises two base plates 301 and 302 (also referred to as leaves) which extend in front of the front wall 118 of the collecting element and form a continuation of the bottom side 116. Each of the base plates 301, 302 forms, together with the screw 200, a cutting device, of which the circumference of the helical part of the screw 200 and the edge of a base plate form a pair of scissors. By turning the screw 200, a scissor movement is produced between the base plates 301, 302 and the helical element of screw 200.

[0097] The device furthermore comprises a protective cover 400 which surrounds the upper side of that part of

the screw 200 which extends in front of the front wall 118.

[0098] The device furthermore comprises a supporting arm 410 which connects the first end 214 of the axis 202 of the screw 200, which end 214 is situated in front of the front wall, to the collecting element 110. As is illustrated in this embodiment, supporting arm 410 and protective cover 400 may form a single entity.

[0099] Furthermore, a motor 218 is provided which is coupled to the second end 216 of the axis 202. The motor 218 is preferably a hydraulic motor. The second end 216 of the axis 202 may be situated in the collecting volume 112, but, as is illustrated in the embodiment in Figs. 1 to 3, the second end 216 may also be situated behind the collecting volume 112. The axis 202 of the screw then protrudes through the rear wall 501 of the collecting element 110. The motor is outside the collecting volume 112, as a result of which soiling of the motor 218 can be limited. If desired, a suitable bearing and/or sealing may be provided between the axis 202 and rear wall 501.

[0100] Each side of the outer wall 114 of the collecting element is formed by a side wall 502 and 503.

[0101] The side walls 502, 503 may, if desired, be provided with hatches or detachable surfaces. The purpose of these is to facilitate access to the interior of the collecting element 110 in order to be able to carry out any necessary maintenance or repair work. The front wall 118 or rear wall 501 may, for the same reason, also be provided with hatches or detachable surfaces.

[0102] On each side of the outer wall 114 of the collecting element, i.e. on each side wall 502 and 503, a side plate 601 and 602, respectively, is attached. The distance between side wall 502 and 503, respectively, of collecting element 110 and side plate 601 and 602, respectively, increases in the longitudinal direction towards the back, as is clearly illustrated in Fig. 3. The angle of inclination between the side wall 502, 503 and side plate 601, 602 may be fixed or adjustable, for example depending on the desired profile of the trenches to be cleared. The adjustment may be dynamic (that is to say be adjustable during clearing) or static (that is to say be adjustable by adjustment before or after clearing). Thus, the side plate 601 on the front side 612 may be hingedly attached in the longitudinal direction to the side wall 502, by means of hinge 610. Furthermore, means are provided for dynamically adjusting or varying the distance between the side wall 502 and the side plate 601 on the rear side 613 of the side plate 601, for example hydraulic plunger 611. In that way it is also possible for the side plate 602 on the front side 622 to be hingedly attached in the longitudinal direction to the side wall 503 by means of hinge 620. Furthermore, means may be provided to adjust or vary the distance between the side wall 503 and the side plate 602 on the rear side 623 of the side plate 602, for example hydraulic plunger 621.

[0103] The bottom side 116 may be formed by a separate bottom wall, or may be integrally formed by both side walls 502, 503. The bottom side and the two base plates may also be formed as a single continuous plate.

Preferably, the base plates and the bottom side of the collecting element are of a curved design, so that a profile is produced at the bottom which to a certain degree follows the profile of the trench. Furthermore, at the front, at the bottom centre of the base plate or between both base plates, a wedge-shaped recess may be provided, which acts as a kind of funnel for the material to be cleared which is at the bottom of the trench.

[0104] The front wall 118, rear wall 501 and side walls 502, 503, if desired with a separate bottom side, thus determine the dimensions of the collecting volume 112. The upper side of the volume which is surrounded by these walls is preferably open. By rotating the device about an axis parallel to the longitudinal direction, the open upper side of the collecting volume can be directed downwards, so that the collected material can be discharged, for example poured out. As a result, the collecting volume 112 of the collecting element 110 is emptied. Alternatively, the upper side of the volume 112 which is surrounded by these walls is provided with a lid (not illustrated). This lid can then be opened, for example under its own weight, when the upper side is directed downwards, so that the collected material can be removed, for example poured out. It will be clear that other systems for emptying the collecting volume 112 are also possible, for example sucking the collecting volume 112 dry.

[0105] The cross section of the collecting element 110 is preferably, but not necessarily, constant in the longitudinal direction 900 of the collecting element 110.

[0106] The surface of the outer walls on the bottom side 116 and side walls 502, 503 is preferably smooth, that is to say free from projecting parts.

[0107] The wall and the components which form the wall may be made from different types of materials, such as plastic, wood, metal and the like. Preferably, hard steel or stainless metal, for example stainless steel, is used for the walls of the collecting element 110.

[0108] The bottom side 116 and the side walls 502, 503 of the collecting element 110 may also be made from one plate, for example by bending the plate, but may also consist of different parts which have been fitted to one another. In the case of metal parts, the connection may be produced by welding the parts to one another. The front wall 118 and the rear wall 501 may also be fitted to the side walls 502, 503 and the bottom wall by, for example, welding in the case of metal parts.

[0109] The height of the front wall 118 and/or rear wall 501 is preferably similar to the height of the side walls 502, 503.

[0110] The screw 200 may be made of material which is suitable for the operating conditions. Suitable material is material which does not or not readily corrode upon contact with the material to be cleared. Dimensions may be adapted to the type of trenches which have to be cleared.

[0111] The device is furthermore provided with a suspension means 700 in order to suspend the device from a carrier, for example from the load arm 770 of a crane,

tractor or any similar other suitable means of transportation, for example vehicle. The suspension means preferably comprises means which are known per se in order to allow the assembly comprising the collecting element with screw and base plate to rotate about two axes: about a vertical axis so that the assembly can follow the course of the trench, and about a horizontal axis so that the assembly can be inclined forwards or backwards.

[0112] The figures, by way of example, show an embodiment of a suspension means 700. According to this example, the suspension means comprises at least one suspension point, but in the illustrated embodiment two suspension points 701 and 702. The suspension means 700 comprise a rigid structure 703 which has a longitudinal profiled section 704 at the top in the longitudinal direction 900 of the device. The suspension points 701 and 702 may, for example, be formed at the ends 741 and 742 of the longitudinal profiled section 704. On each of the suspension points 701, 702, an element is provided for varying the orientation of the longitudinal direction 900. In the illustrated embodiment, two hydraulic plungers 751 and 752 are provided for this purpose. The length of the plungers 751, 752 can be adjusted by the operator. By varying the length of the plungers 751 and 752, the orientation of the longitudinal profiled section 704, that is the orientation of the collecting element 110, with respect to the carrier can be modified.

[0113] Between the longitudinal profiled section 704 and one of the side walls, in the illustrated embodiment side wall 502, a cover plate 705 may be provided. The latter can guide the cleared material 920 which has been collected in the collecting element 110 when the open upper side of the collecting volume 112 is oriented downwards, so that the collected material 920 can be poured out. The cover plate 705 also protects the surroundings from cleared material which could escape from the volume while it is being pumped up.

[0114] The device is furthermore provided with a sloping plate 800 which is attached to the rear wall 501 of the collecting element 110 and which extends over the motor housing. When the device is used, the screw 200 pumps up cleared material and water or liquid from the trench, all of which is collected in the collecting volume 112. Cleared material sludge tends to be rather heavy, and some of the water or liquid is already separated in the collecting volume 112. When the collecting volume 112 is full, this does not mean that the collecting volume 112 is completely filled with cleared material sludge. The top part of the volume 112 is filled with a suspension comprising liquid, for example water, and sand or soil, which may be returned to the trench. By continuing to pump and clear the trench, this liquid/sand or liquid/soil mixture flows over the edges of the outer walls 114 to the outside. In order to prevent this stream from continually flowing over the motor 218, the sloping plate will lead some of the overflow so it runs behind the motor 218 and the motor housing (if present). In order to produce preferential flows of the mixture, the rear side 501 may be provided

with one or more openings 810. Side walls 502, 503 and/or front wall 118 can also be provided with such openings (not illustrated). If desired, these openings may be closed or opened by means of a closure, for example a movable shutter, such as for example a rotatable shutter.

[0115] Embodiments of a device according to the present invention may have various dimensions, depending on the dimensions of the trenches to be cleared. The device has a total length 1001 in the longitudinal direction. The collecting element 110 has a length which is made up of a length 1003 over which the screw 200 is present in the volume 112, and a length 1002 over which the screw 200 is not present in the volume 112. The device is furthermore characterized by a total height 1005 from bottom side to upper side of side wall 502, 503, rear wall 501 and/or front wall 118, and a width 1008.

[0116] A part of the screw, denoted by 204, is situated in front of the front wall 118 outside the collecting volume 112. A part thereof (denoted by 206) protrudes below the bottom side 116. The part of the screw 200 (denoted by 206), which protrudes below the bottom side 116, is characterized by a depth 1006 by which the screw 200 protrudes below the bottom side 116. The screw may have a minimum diameter 1011 of approximately 150 mm and may have a maximum diameter 1010 of approximately 950 mm.

[0117] The device may be designed such that the dimensions of the walls, bottom side, parts of the screw which extend in front of the front wall or distance by which the screw projects below the bottom side, are adjustable.

[0118] The device may furthermore be provided with tools such as a brush for completely or partially cleaning culverts or pipes which flow out into the trench.

[0119] A second embodiment of the invention is represented in Figures 4, 5 and 6. This embodiment contains many elements which are identical or similar to the elements which have already been described in relation to the first embodiment and with the same reference numerals in the figures; a description thereof is therefore omitted here. According to the second embodiment, the rotatable element, in addition to a screw for moving cleared material 920, comprises at least one knife, in this embodiment four substantially identical knives 152. The rotatable element thus forms part of a means for moving cleared material in front of the collecting element towards the collecting volume.

[0120] The screw 200 is rotatable about the axis 207 of the rotatable element 150, which is thus also the axis 202 of the screw 200. The positioning of the screw with respect to the collecting element and with respect to the base plate or base plates is virtually identical to the arrangement shown in the first embodiment.

[0121] The knife, in the illustrated embodiment the four knives 152, of the rotatable element 150 is fitted to a carrier, for example an substantially circular carrier 154. In the case of four knives 152, as in the illustrated embodiment, these knives 152 form an angle of approxi-

mately 90° with respect to each other. The knives 152 may be oriented substantially at right angles to the axis 207 of the rotatable element. The knives 152 may be fitted in such a manner that at least one, and in this embodiment each of the knives 152, can protrude below the bottom side 116. In certain embodiments, the maximum distance 1009 by which the knives can protrude below the bottom side 116 is between 1 cm and 50 cm in the vertical direction. The point of the knives which is furthest from the front wall 118 extends in front of the front wall 118 over a distance 209 of for example 5 cm to 200 cm in the longitudinal direction 900.

[0122] The axis 207 forms an angle with the longitudinal direction 900 of substantially 0°. A small inclination between 0° and for example, but not limited to, 20° may be advantageous. In the figure, the knives are positioned at an angle of 90° to the axis (202). The knives can also be positioned at another angle to this axis, for example so that when the knives rotate, the cleared material is thrown backwards.

[0123] According to this embodiment, the protective cover 400 also partially surrounds the knives 152.

[0124] Along the part of the axis 207, between the end of the screw 200 and the rear wall 501, the axis may, if desired, be provided with further radially protruding fins, or with elements which move or push the cleared material, which is present in this part of the axis in the collecting volume, further towards the rear wall. This has the advantage that the cleared material in the collecting volume is distributed more evenly over the entire collecting volume. Such fins can also be provided in other embodiments.

[0125] Each side of the outer wall 114 of the collecting element is formed by a side wall 502 and 503.

[0126] The knives 152 are fitted in the radial direction on a carrier, for example substantially circular carrier 154. The carrier 154 may be made of material which is suitable for the operating conditions. Suitable material is material which does not or not readily corrode upon contact with the material to be cleared. The carrier 154 can be attached to a coupling piece 155 on the axis 207 by means of a simple securing system (for example bolts). If required, the carrier 154 and the knife or the knives 152 can be detached in a simple manner and, if desired, be replaced with another carrier with one or more knives, which may be identical to the carrier with knives to be replaced or which may comprise a different number of knives, or knives made from another material or having different dimensions.

[0127] The knives 152 are made from a material which is suitable for the operating conditions, for example treated steel. The knives 152 may be cutter knives. The knives 152 have, for example an end 153 which projects forwards with respect to the carrier 154.

[0128] Features indicated in the first embodiment can also be used in the second embodiment and vice versa.

[0129] According to an alternative embodiment of the device for clearing material from a trench (not illustrated

in the figures), the knives, which are rotatable about the axis of the rotatable element, and which are situated between the screw and the first end of the axis, are fitted to the screw itself. The rotatable element thus again protrudes below the bottom side, at least by means of these knives. The part of the screw which extends in front of the front side may also partially protrude below the bottom side.

[0130] A third embodiment of the invention is illustrated in Figures 7, 8 and 9. The device according to the third embodiment is largely similar to the device according to Figures 4, 5 and 6, and in part also to the device from Figures 1, 2 and 3. Identical reference numerals therefore refer to identical or similar components. The description of elements which have already been described in the first or second embodiment is generally not repeated. According to this third embodiment, the rotatable element, in addition to a screw 200 for displacing cleared material 920, comprises at least one knife, in this embodiment four substantially identical knives 172. In this embodiment, the screw 200 and the knives 172 rotate about different axes.

[0131] The front wall 118 of the collecting element 110 is provided with an opening 120 which is situated on the upper side of the front wall 118. In an alternative embodiment, the front wall does not extend over the total height 1005 of the device, and the front wall is not provided along the top part of the collecting element. The rotatable element 170 is part of a means for displacing cleared material in front of the collecting element 110 towards the collecting volume 112, in this case via the opening 120 in the front wall 118.

[0132] The rotatable element 170 is rotatable about an axis 207.

[0133] The four knives 172 of the rotatable element 170 are, in the illustrated embodiment, fitted to a carrier, for example a substantially circular carrier 174, and are at a mutual angle to each other of approximately 90°. The knives 172 are essentially oriented at right angles with respect to the axis 207. The knives 172 are fitted in such a manner that each of the knives can protrude below the bottom side 116. In certain embodiments, the maximum distance 1009 by which the knives 172 can protrude below the bottom side 116 is between 1 cm and 50 cm in the vertical direction. The point of the knives 172 which is furthest away from the front wall 118 extends in front of the front wall 118 over a distance 209 of for example 5 cm to 200 cm in the longitudinal direction 900. In this embodiment, the axis 207 forms an angle with the longitudinal direction 900 which differs from 0°. An angle of between 0° and 80°, for example between 0° and 60° or between 0° and 45°, may be used. It is likewise possible to use smaller angles, for example an angle of 10°. The rear of the axis 207 is tilted downwards with respect to the longitudinal direction 900. The axis 207 may also be tilted outwards. The device may furthermore be provided with a means to make the angle between the longitudinal direction 900 and the axis 207 (more particularly both the

inclination forwards or backwards and/or the lateral inclination) variable or adjustable.

[0134] By rotation of the knives 172, in combination with the orientation of the axis 207 which is not parallel with the longitudinal direction 900, cleared material is thrown upwards and backwards in the direction of opening 120. Via this opening 120, cleared material 920 is collected in the collecting volume 112 of the collecting element 110. In an alternative embodiment, in which the front wall 118 does not comprise an opening, but in which the front wall does not extend over the entire height 1005 of the collecting element 110, the rotation and inclination of the rotatable element 170 will throw the cleared material over the upper side or upper edge of the front wall 118, into the collecting volume 112 of the collecting element 110.

[0135] When emptying the collecting volume 112, as will be explained further below, the cleared material will have less of a tendency, if at all, to flow from the collecting volume of the collecting element via the opening in the front wall. When emptying the device according to Fig. 1, it is possible that some cleared material may leak through the opening when the collecting volume is being emptied if the screw does not rotate sufficiently fast to prevent leakage via the opening. With the device according to Fig. 6, the level of the cleared material in the collecting volume can be kept below the bottom side of the opening in the front wall.

[0136] The device may furthermore comprise two base plates 301 and 302 which extend in front of the front wall 118 of the collecting element 110 and form a continuation of the bottom side 116. Each of the base plates 301, 302 may serve as a guide to guide the device in the trench.

[0137] The device may furthermore comprise a protective cover 400 which surrounds the upper side of that part of the rotatable element 170 which extends in front of the front wall 118. The protective cover 400 may be attached to the front wall 118, for example above the upper edge 401 of the opening 120. The protective cover 400 acts as a guiding element 402. Cleared material 920 which is thrown upwards and backwards by the knives 172 in the direction of the front wall 118 is guided towards and even past the opening 120 by the guiding element 402.

[0138] In this way, the cleared material 920 ends up in the collecting volume 112.

[0139] A screw 200 may be fitted inside this collecting volume 112. By rotation, the screw 200 will move the cleared material 920, which is thrown or guided through the opening 120 onto the screw 200, backwards and keep it in the collecting volume 112. The screw 200 can, but does not necessarily have to be installed closer to the side wall 502 than to the side wall 503. The screw 200 can also be installed at an equal distance from both side walls 502 and 503, or also closer to side wall 503. Cleared material which is thrown onto the screw 200 will be moved to the rear wall 501 by the rotation of the screw, as a result of which the collecting volume 112 can be filled

more efficiently and to a greater degree, in particular if the cleared material 920 is relatively dry material.

[0140] In alternative embodiments, the screw 200 may protrude through the opening 120 in the front wall 118, or above the upper edge of the front wall 118 (not illustrated). The cleared material which is thrown onto the screw 200 by the rotatable element 170 will be moved to inside the collecting volume 112 by rotation of the screw 200. In yet another alternative embodiment, the screw 200 may be replaced by a conveyor belt for displacing cleared material. The material may be thrown onto the conveyor belt by the rotatable element 170, and subsequently be moved to the collecting volume 112.

[0141] Furthermore, a motor 218 is provided which is connected to the axis 202 of the screw 200 and the rotation axis 207 of the rotatable element 170. The latter may be effected by means of a cardan shaft 520. The axes are coupled to the motor 218 by means of suitable transmissions 521. In certain embodiments, the motor 218 is a hydraulic motor. It is advantageous if the motor 218 is arranged outside the collecting volume 112, as the risk of it becoming soiled is limited in this manner. The cardan shaft 520 which connects the axis 207 of the rotatable element 170 to the motor 218, if desired via transmission 521, then protrudes through the rear wall 501 of the collecting element 110. The axis 202 of the screw 200, which couples the screw 200 to the motor 218, if desired via transmission 521, then also protrudes through the rear wall 501 of the collecting element 110. If desired, a suitable bearing and/or sealing is provided between the axis 202 and rear wall 501 on the one hand and the cardan shaft 520 and the rear wall 501 on the other hand. The motor 218 and/or the transmission 521 may be designed to drive the axis 207 and/or the axes 202 in only one direction of rotation or may be designed to drive the axes 202 and/or 207 in both directions of rotation.

[0142] Along the part of the axis 202 between the end of the screw 200 and the rear wall 501, the axis may, if desired, be provided with further radially projecting fins or with elements which move the cleared material, which is present along this section of the axis in the collecting volume 112, further towards the rear wall 501. This offers the advantage that the cleared material in the collecting volume 112 is distributed more evenly over the entire collecting volume 112.

[0143] In order to spread the cleared material over the entire collecting volume 112, it is possible to provide additional screws or axes with projecting fins or distribution elements in the collecting volume 112, for example at the bottom side of the collecting element 110 on the inside thereof and along part or the entire length of the collecting volume. Rotation of these additional axes or screws will result in spreading the cleared material in the collecting volume 112.

[0144] The device may furthermore comprise a screen 420. As is illustrated in the embodiment in Fig. 4, the screen 420 and protective cover 400 may form a single

entity.

[0145] It will be clear that, if desired, it is possible to use two separate motors in this embodiment. One of the motors can be used to drive axis 207, the other one to drive the axis 202. The motor or motors can also be fitted in the collecting element 110. The motor or motors can be designed to drive the axis 207 and axis 202, respectively, in only one direction of rotation or may be provided to drive the axes 207 and 202, respectively, in both directions of rotation. In an alternative embodiment, the screw 200 and the rotatable element 170 can be driven by two separate motors, with the motor which drives the rotatable element 170 being situated in the space between the rotatable element 170 and the front wall 118. The motor may be suspended from the collecting element 110 in such a manner that it can be coupled, for example, to the front wall 118, by means of for example a rail system with rails which are oriented in a vertical position, that is in the vertical direction, of the collecting element 110. The motor can be moved up or down on the rails, with the distance by which the rotatable element 170 protrudes below the bottom side 116 being adjustable. It is also possible to connect the motor to the rail system by means of a coupling, which coupling system allows the orientation of the axis of the rotatable element 170 to be varied and/or adjusted with respect to the longitudinal direction 900.

[0146] In each of the three above-described embodiments, plates or discs can at the front, which extend in front of the device and form a funnel in order to guide the material to be cleared to the rotating element, the knives or the screw. These plates are then arranged in an inclined position with respect to a vertical plane in order thus to create a good funnel action. These plates or discs can also be replaced by two supporting arms, one on each side of the device, with a chain curtain being attached to each of the supporting arms.

[0147] According to another aspect of the invention, a method for clearing trenches is provided. In this case, a device according to the invention, which has been described above by way of example, is coupled or fitted to, for example suspended from, the mechanical arm or load arm 770 of a carrier, preferably a vehicle, for example a tractor or a crane. As has been indicated above, the coupling may comprise means which ensure that the device can be rotated about a substantially vertical axis 720. Also, the load arm 770 can rotate the device about an axis 730 which is substantially parallel with the longitudinal direction 900 of the device. Furthermore, the load arm 770 ensures that the device can be moved up and down in the vertical direction. The coupling may also comprise means which ensure that the device can be rotated about a horizontal transverse axis, at right angles to the longitudinal direction.

[0148] The device is lowered into a trench to be cleared. This may be carried out by the load arm 770 of the carrier, for example the vehicle, being manoeuvred by an operator. The depth is usually determined by the

position of the bottom side of a culvert, for example a longitudinal culvert or a transverse culvert, which is present on one of the sides of the trench. Preferably, the bottom side 116 of the device is brought into contact with the bottom of the trench to be cleared. If desired, the orientation of the longitudinal direction 900 can be adjusted.

[0149] Subsequently, the device is moved along in the longitudinal direction 900 while the screw 200 is rotated about its axis 202 for collecting cleared material 920 in the collecting volume 112. The rotation of the screw 200 ensures that material which touches the screw 200 is pumped up towards the collecting volume 112 as a result of the latter being moved forward in the longitudinal direction. A part of the material is loosened on the bottom of the trench by the screw part which protrudes below the bottom side 116 of the collecting element 110. Possibly, grasses, weeds and other plants are cut between the screw 200 and the base plates 301, 302, if these are provided.

[0150] A part of the loosened bottom is also pumped up, often in the form of sludge. Another part, together with water or liquid which may be present in the trench, flows under the bottom side and past the walls of the collecting element 110. This ensures that the bottom and walls are lubricated as it were and are pushed by a mixture of sand or soil and liquid. This effect, which may be further amplified by the presence of, optionally adjustable, side plates 601, 602, results in a cleared trench with a smooth and dimensionally correct profile. By cutting the vegetation and providing a layer of sand or soil with liquid, the remaining parts of the vegetation which are still present in the trench wall and trench bottom are provided with nutrition and can regrow. As a result, the flora of the trench is able to recover quickly after clearing.

[0151] It is obvious that the use is not restricted to straight trenches. By manoeuvring and adjusting the device in the trench, it is obviously also possible, to follow the line of the trench. This adjustment may be carried out by the carrier, for example the vehicle, which follows the trench wall, or may be carried out by rotating the device about the axis 720.

[0152] During clearing, the collecting volume 112 will be filled with cleared material 920 and liquid. A part of the liquid will already separate from the heavier sludge and the mud and other cleared material. This liquid may, if possible, already leave the collecting volume 112 by overflowing and thus return to the trench from where it was taken.

[0153] Once the collecting volume 112 is filled with cleared material 920, the device is raised from the trench. This may again be effected by moving the load arm 770 of the carrier, for example the vehicle, upwards. The load arm 770 may move the device above a container, for example a high-walled container. This container may, for example, be moved along by the same vehicle. By rotating the device about the axis 730, the open upper side of the collecting volume 112 is oriented downwards, so

that the collected material 920 can be poured out, and consequently the collecting volume 112 of the collecting element 110 is emptied into, for example, the high-walled container.

[0154] Once the collecting volume 112 has been emptied, the device can again be lowered into the trench to be cleared, more particularly into the continuation of the same trench which has already partially been cleared, or into another trench to be cleared.

[0155] As is illustrated in Fig. 10, when starting to clear a trench (reference numeral 1401), the device 1400, for example a device according to Figures 1 to 9, coupled to a vehicle 1440, can be lowered into the trench at a position between two culverts (1410 and 1420). The part of the trench between first culvert 1410 and device 1400 is cleared as indicated above in the direction denoted by arrow 1403. Once this part of the trench has been cleared up to the first culvert 1410, the device is lifted from the trench, turned by 180° about axis 720 and lowered again (reference numeral 1402), so that the bottom side of the device 1400 is situated at the part 1411 of the trench which has already been cleared. The device 1400 is now used to clear the part of the trench between the cleared part 1411 and the second culvert 1420, as described above, in the direction indicated by arrow 1404.

[0156] In a similar manner, clearing can be carried out around trees, posts and other obstacles which are situated on the banks of the trench. This is carried out by first clearing the trench on one side of the obstacle, to beyond the obstacle, moving the device to the other side of the obstacle and turning it around, and then clearing in the other direction, again to beyond the obstacle.

[0157] The cleared material 920 may be transferred from the device 1400 to a receptacle, for example a high-walled container 1450. This high-walled container 1450 may be towed by the vehicle 1440. During the time when the high-walled container 1450 is coupled to the vehicle 1440, a part of the water may already separate from the sludge and the cleared material. The container 1450 may then also have facilities to return this water to the trench from where it was taken. Alternatively, the container 1450 may have facilities to discharge the water to another location.

[0158] As soon as the high-walled container 1450 is full, the cleared material 920 is dumped in a settling container 1500 for separating sludge and water, as illustrated in Fig. 11. This settling container 1500 is preferably a displaceable container and is usually positioned somewhere near a site where trenches have to be cleared. The settling container 1500 is a substantially rectangular container having a bottom 1501, a front wall 1502, a rear wall 1503 and a first and second side wall, which together form a watertight volume. The settling container 1500 is provided with at least one dividing wall 1508 which is positioned between the front wall 1502 and the rear wall 1503.

[0159] The formed sections or compartments of the container, in the illustrated example the first compartment

1510 between the front wall 1502 and the dividing wall 1508, and the second compartment 1520 between the dividing wall 1508 and the rear wall 1503, can be filled with cleared material 920 up to a certain height. Once the settling container 1500 is full, the latter is, if desired, pulled onto a trailer and the cleared material 920 is transported away to be processed further. By sedimentation, the water separates from the sludge and other material.

[0160] In order to separate the water from the other material of the cleared material on site or after transportation, the upper side of the rear wall 1503 is provided with an opening 1523 to allow water to flow out. Likewise, the upper side of the dividing wall 1508 is provided with an opening 1528 to allow water to flow out. After the sediment 1550 has already partly settled out of the cleared material, the container 1500 can be tilted slightly, for example by lifting the front side. In this manner, the water volume 1560 which is on top of the sediment rises above the opening. This results in the water 1560 flowing through the openings 1523 and 1528, i.e. from the first compartment 1510 of the container 1500 to the second compartment 1520, and from the second compartment 1520 out of the container 1500. If desired, this may be collected via a discharge pipe 1570. When the settling container 1500 is still on site, the discharge pipe can return the water to one of the cleared trenches.

[0161] The settling container 1500 may be positioned at a fixed location on site or, if desired, be moved regularly in order to limit the displacement time between trenches to be cleared and settling container.

[0162] Alternatively, the water 1560 may be sucked up to a vacuum chamber via suitable lines, for example the vacuum device of a cess pit.

[0163] Fig. 12 shows a detail of a container. Fig. 12 shows the rear wall 1503 of the container 1500 which is provided with an opening 1523. On the inner side 1530 of the rear wall 1503, the opening is preferably covered by a shutter 1532. This shutter is movably, for example rotatably, arranged about axis 1533 and can preferably be operated from outside the container, that is be rotated about the axis 1533. In order to prevent solid matter, such as cans or branches, from flowing along through the opening when water flows out, the opening may be provided with a trapping system, for example lattice work 1534.

[0164] On the outer side 1531 of the container 1500, the container 1500 is provided with a chamber 1535, which preferably extends over at least the perimeter of the opening 1523. Water which flows through the opening 1523 is collected in this chamber 1535. The chamber is designed in such a manner that the water which flows through the opening 1523 is diverted to a passage 1536 to which a discharge pipe (not illustrated) can be coupled. This passage may already be provided with a coupling piece 1537, for example a part of a rapid-action coupling. If desired (not illustrated in Fig. 6), the passage 1536 may be provided with a shut-off cock, for example between the passage 1536 and coupling piece 1537. The chamber

1535 is preferably a closed chamber. The closed chamber may be provided with safety features, for example a safety valve 1538. In case the chamber is connected to a vacuum chamber, for example of a cesspool, in order to suck water out of the chamber, this safety valve will ensure that the pressure in the chamber, in case the shutter 1532 accidentally shuts or in case of an accumulation of solid matter on the trapping system, for example the lattice work 1536, does not become so low that the walls of the container and/or the chamber are damaged or deform too much as a result of the underpressure which has been created. This valve 1538 may be an opening, which is provided on the inside with a rigid piece of rubber.

[0165] The opening 1528 in the dividing wall 1508 may also be provided with a movable, for example rotatable, shutter and provided with a trapping system, for example lattice work, to trap solid matter. This shutter can also preferably be operated from outside the container.

[0166] As has already been indicated above, the container 1500 can be arranged in an inclined position in order to discharge the water, which is separated from the sludge, via the openings 1523 and 1528. In order to make this possible, the shutters on the openings 1523, 1528 are opened, so that the water can flow through the openings 1523, 1528. When moving the container 1500, upon which the container 1500 is pulled onto a trailer, the shutters are closed in order to prevent that water and possibly also sludge, which can reach up to the level of the openings, can flow through the openings at the large angles of inclination which occur while the container 1500 is being pulled onto a trailer. In order to facilitate pulling the container 1500 onto the trailer and to increase the possible sludge content of the container 1500, the rear wall 1503 and, if desired, the dividing wall may furthermore be provided with an additional upright edge 1539, which may even be inclined inwards with respect to the container 1500.

[0167] The above-described embodiments and methods illustrate the invention as a combination of different elements and characteristics. To those skilled in the art, it will be clear that other combinations are also possible without departing from the scope of the present invention.

[0168] The invention has been described mainly in connection with its use in clearing trenches. However, the invention can also be used for digging or deepening trenches. Where the description mentions the clearing of trenches, this also includes the digging and deepening of trenches.

[0169] Although the invention has been described by means of preferred embodiments, it will be clear to those skilled in the art that various modifications and changes with respect to shape and detail are possible without departing from the scope of protection of the claims for the present invention.

Claims

1. Device (1400) for clearing material from a trench or for digging or deepening a trench, and adapted to be moved in the trench and in a direction of clearing or in a direction of excavating, in which the device comprises:
 - a receiving device,
 - at least one base plate (301, 302)
 - means for moving cleared material away from the front of the base plate (301, 302) in a direction opposite to the direction of clearing or excavating,
 - wherein the means for moving cleared material comprises at least one rotatable element (200, 152), which is rotatably arranged about an axis (202, 207), the axis (202, 207) being arranged in the direction of movement and making an angle of 0° to 80° to a horizontal plane and wherein a part of the rotatable element (200, 152) extends in front of and below the level of the base plate.
2. Device (1400) according to claim 1, wherein the rotatable element comprises a screw (200).
3. Device (1400) according to claim 2, wherein that part of the screw which is situated above the base plate and in front of the base plate has a diameter which increases in the direction of clearing.
4. Device (1400) according to claim 3, wherein the front side of the base plate together with the screw form a cutting device.
5. Device (1400) according to one of the preceding claims, wherein the rotatable element comprises at least one knife which is in front of the receiving device in the direction of clearing or excavating and upon rotation about the axis protrudes at least partly below the base plate in at least one rotary position.
6. Device according to one of the preceding claims, wherein the receiving device comprises a collecting element and wherein the means for moving cleared material is arranged such that this means moves the cleared material towards the collecting element.
7. Device (1400) according to claim 6, wherein the rotatable element is adapted to throw the cleared material in the direction of into the collecting element (110) upon rotation.
8. Device (1400) according to claim 7, wherein the device furthermore comprises guiding elements (402) for guiding the cleared material thrown up by the rotatable element (170) towards the collecting element

- (120).
9. Device (1400) according to one of claims 1 to 8, wherein the collecting element has a front wall (118) and the device comprises a protective cover (400) which surrounds at least the upper side of that part of the rotatable element (150, 170) which extends in front of the front wall (118). 5
10. Device (1400) according to claim 6, wherein at least one, optionally laterally movable, side plate (601, 602) is coupled to the collecting element for smoothing an upright trench wall. 10
11. Device (1400) according to one of claims 1 to 10, wherein the device has a suspension means (700) in order to suspend the device from a carrier (770) by means of at least one suspension point, wherein the suspension means comprises an element for varying the orientation of the direction of clearing of the device. 15
20
12. Method for clearing a trench, comprising:
- providing a device according to one of claims 1 to 11; 25
 - lowering the device into the trench to be cleared;
 - moving the device through the trench in longitudinal direction while rotating the rotatable element about its axis for collecting cleared material in a collecting volume; 30
 - raising the device from the trench;
 - removing the cleared material from the collecting volume of the device. 35
13. Method according to claim 12, wherein the device is suspended from a vehicle and the removal of the cleared material from the collecting volume of the device is effected by pouring out the cleared material into a high-walled container which is moved by the vehicle. 40
14. Method according to one of claims 12 and 13, wherein the cleared material is furthermore discharged into a settling container for separating sludge and water. 45
15. Method according to claim 14, wherein the settling container is a substantially rectangular container having a bottom, a front wall, a rear wall and a first and second side wall, which together form a watertight volume, in which the upper side of the rear wall is provided with an opening for allowing water to flow out. 50
55
16. Method according to claim 15, wherein the settling container is arranged in an inclined position so that the front wall is in a higher position than the rear wall.
17. Method according to claim 16, wherein the settling container is furthermore provided with at least one dividing wall, positioned between the front wall and the rear wall, the upper side of which dividing wall is provided with an opening for allowing water to flow out.

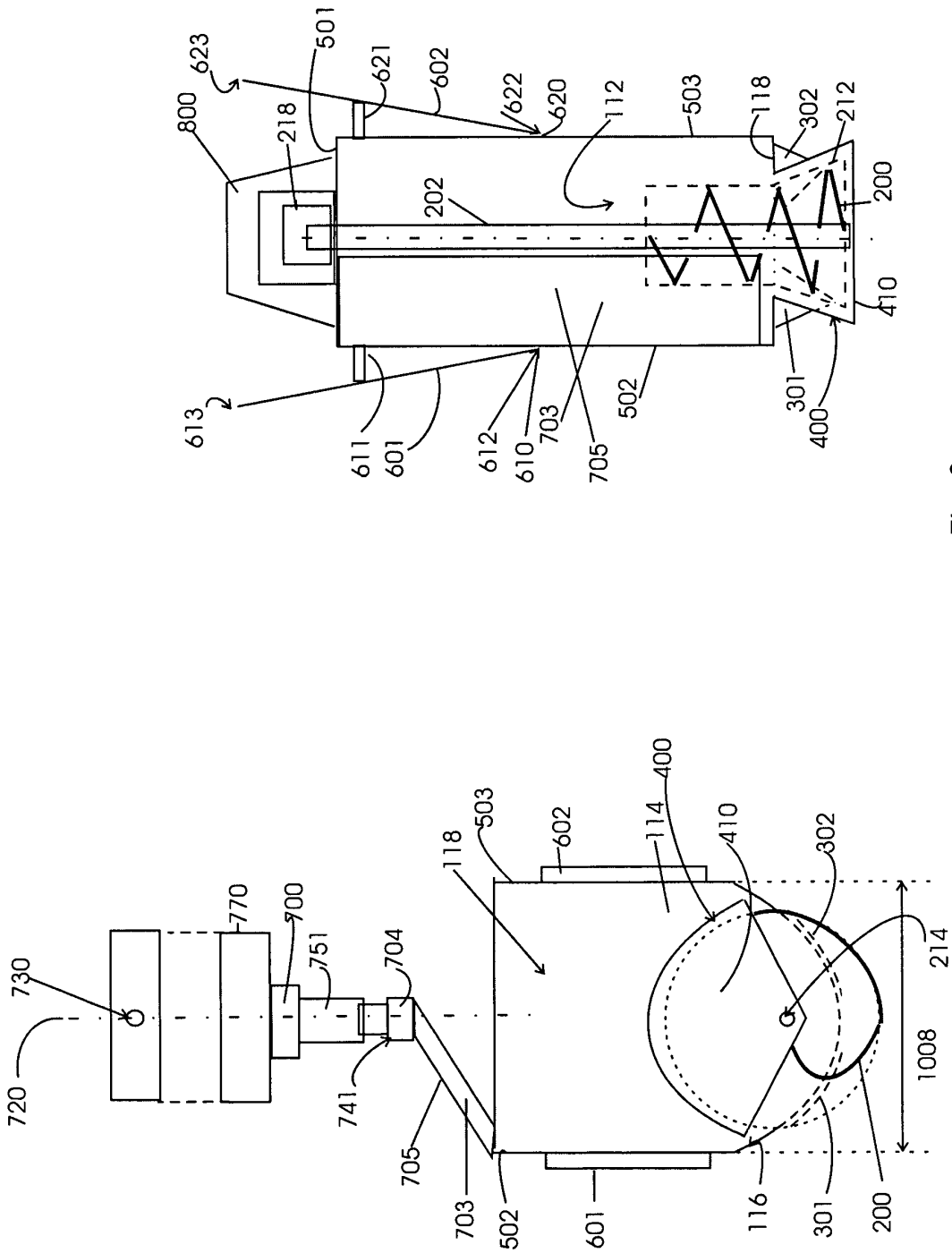
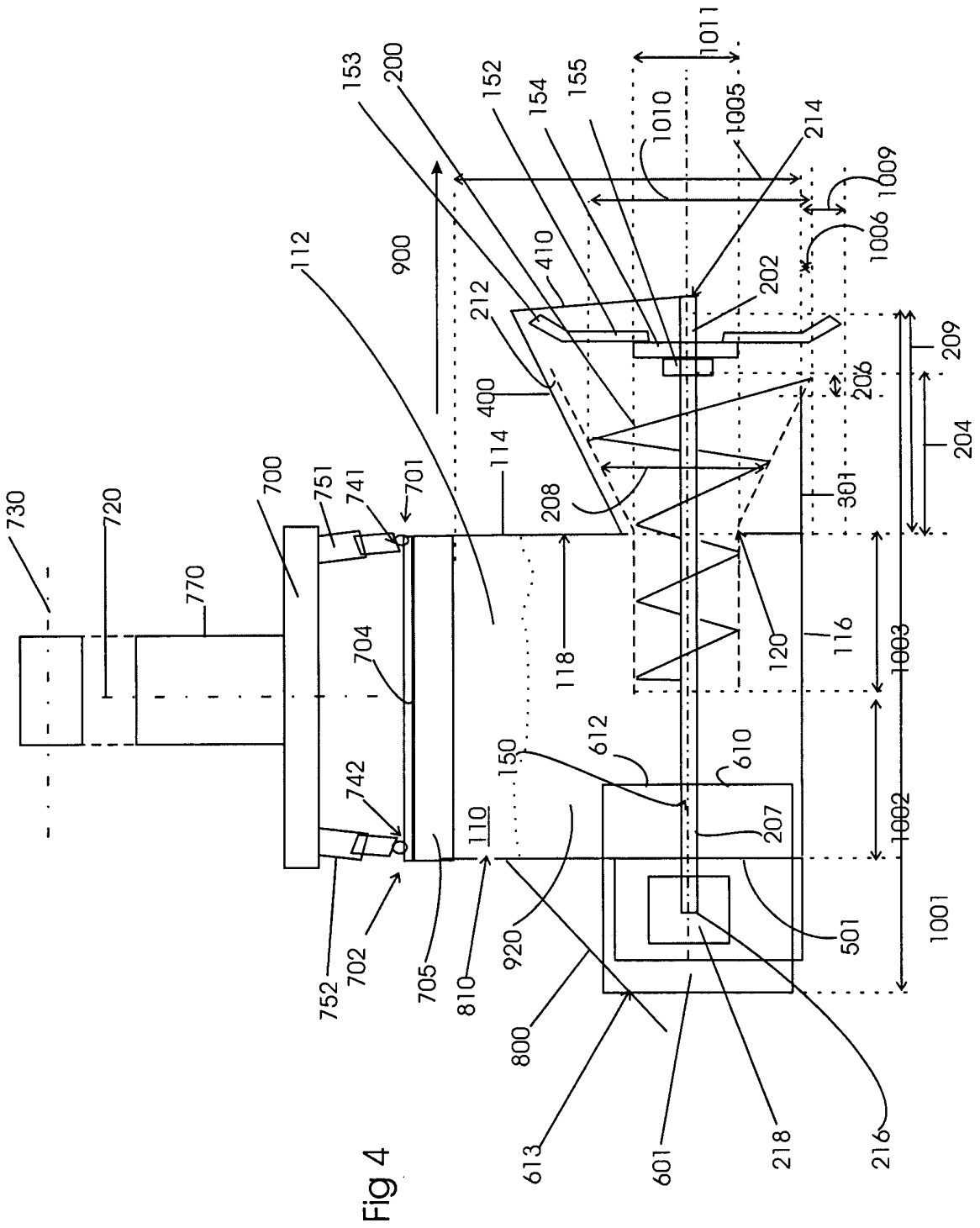

Fig 3

Fig 2



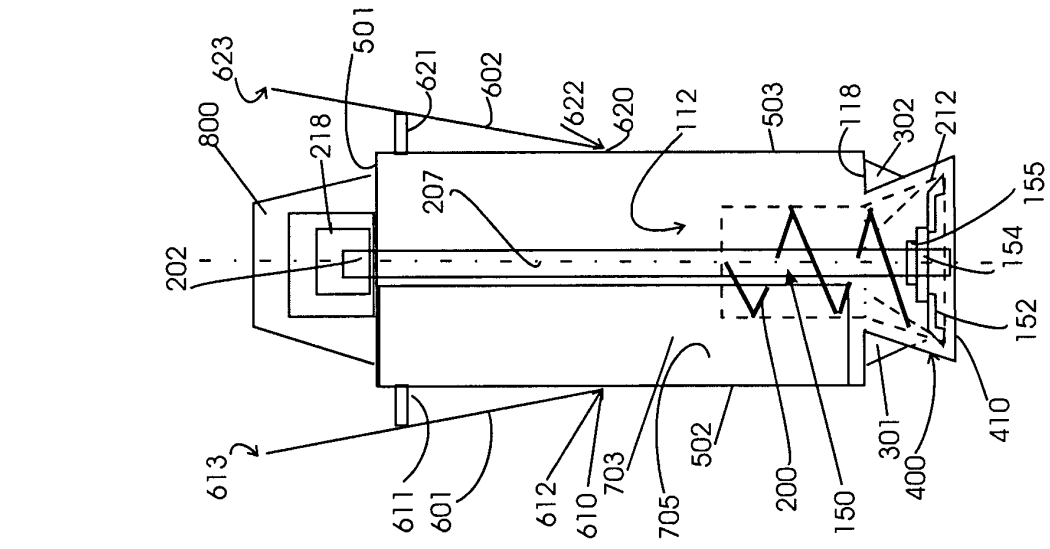

Fig 6

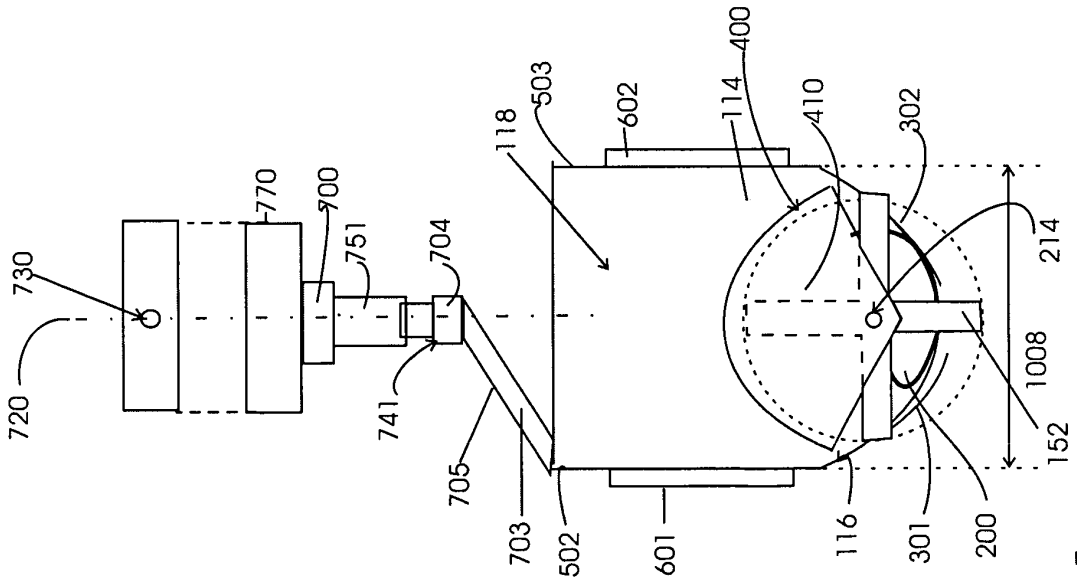
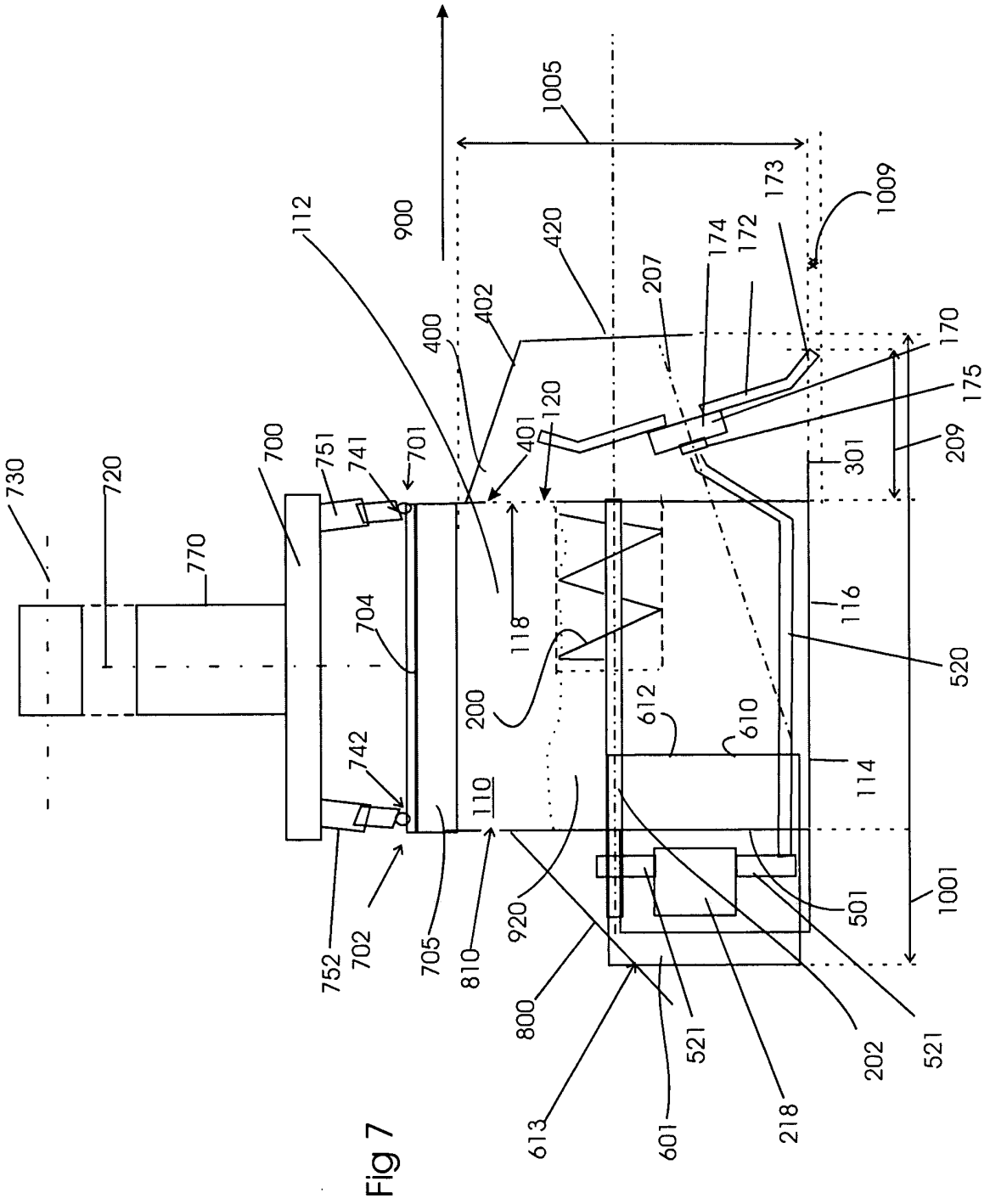

Fig 5



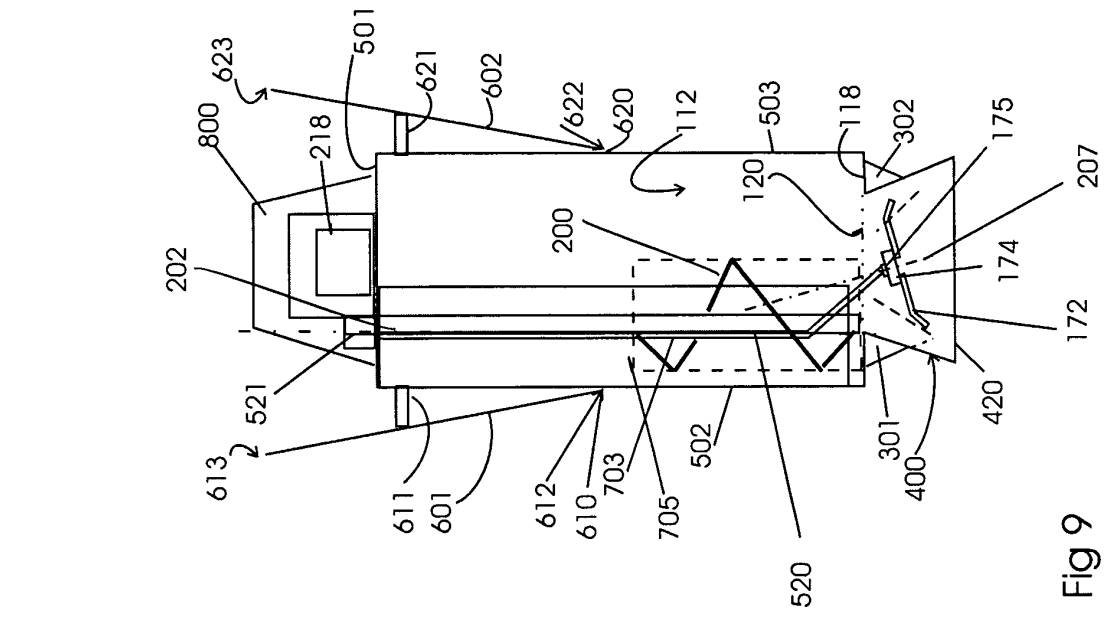

Fig 9

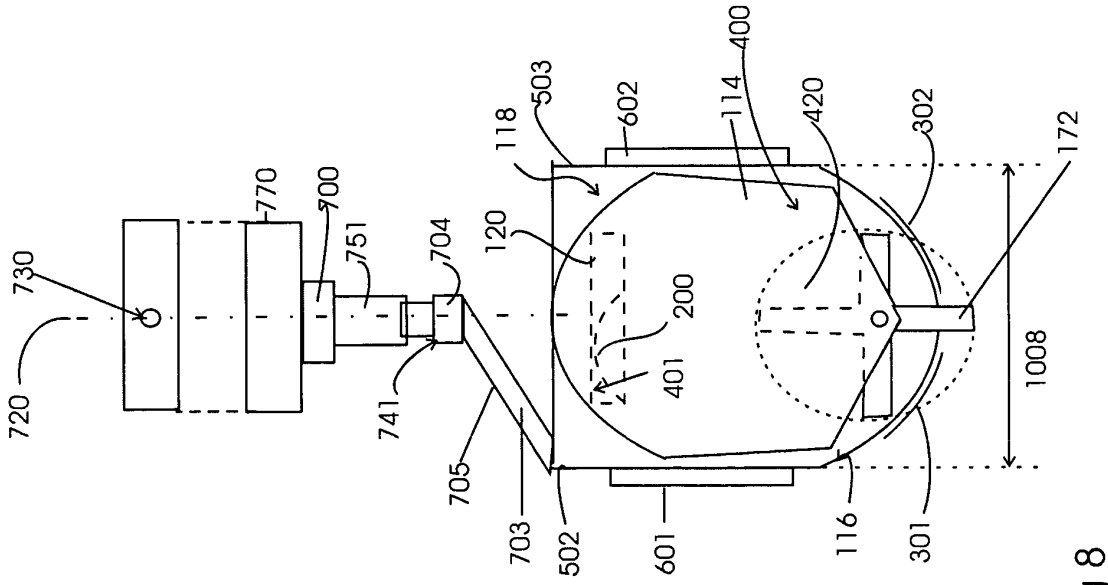
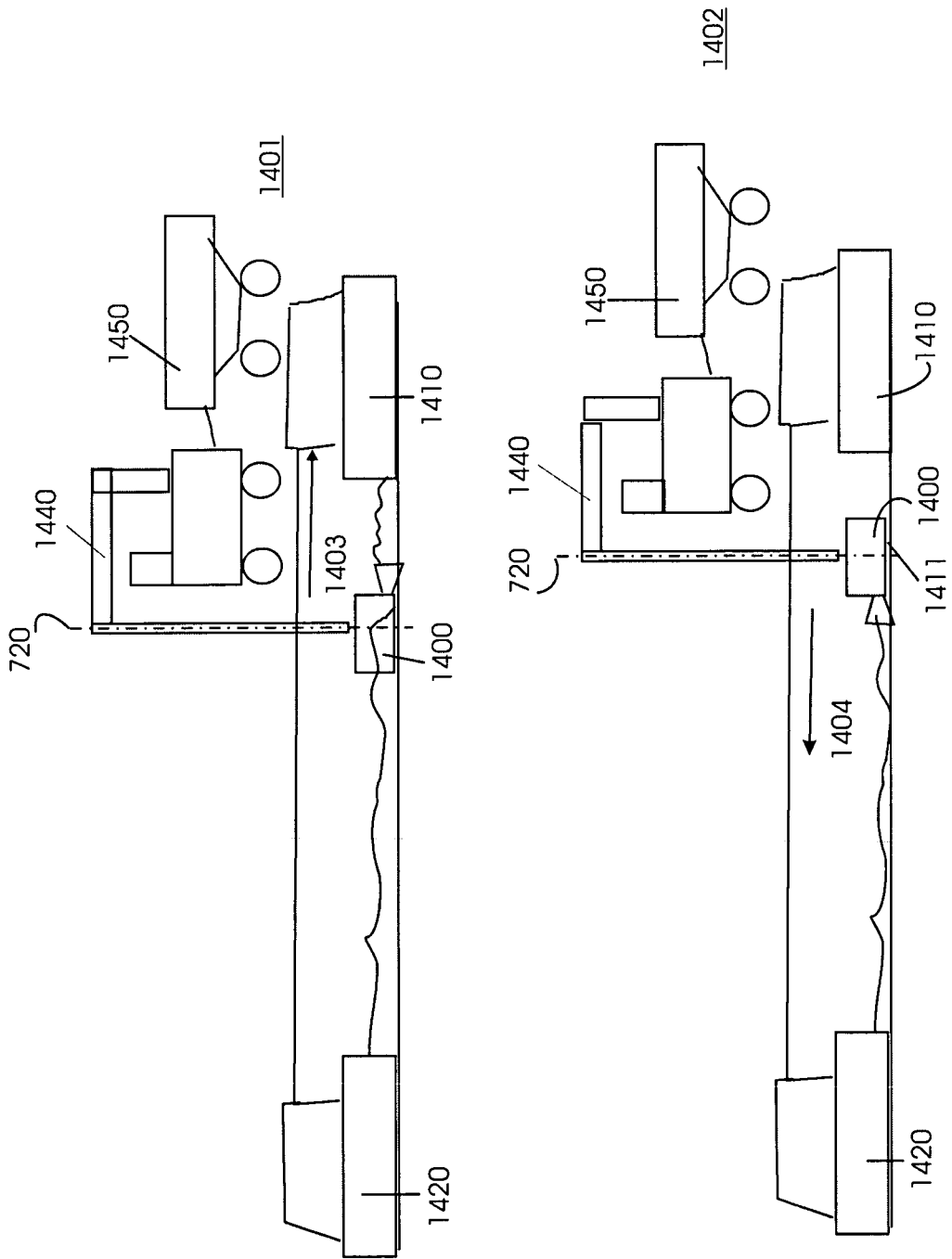

Fig 8

Fig 10



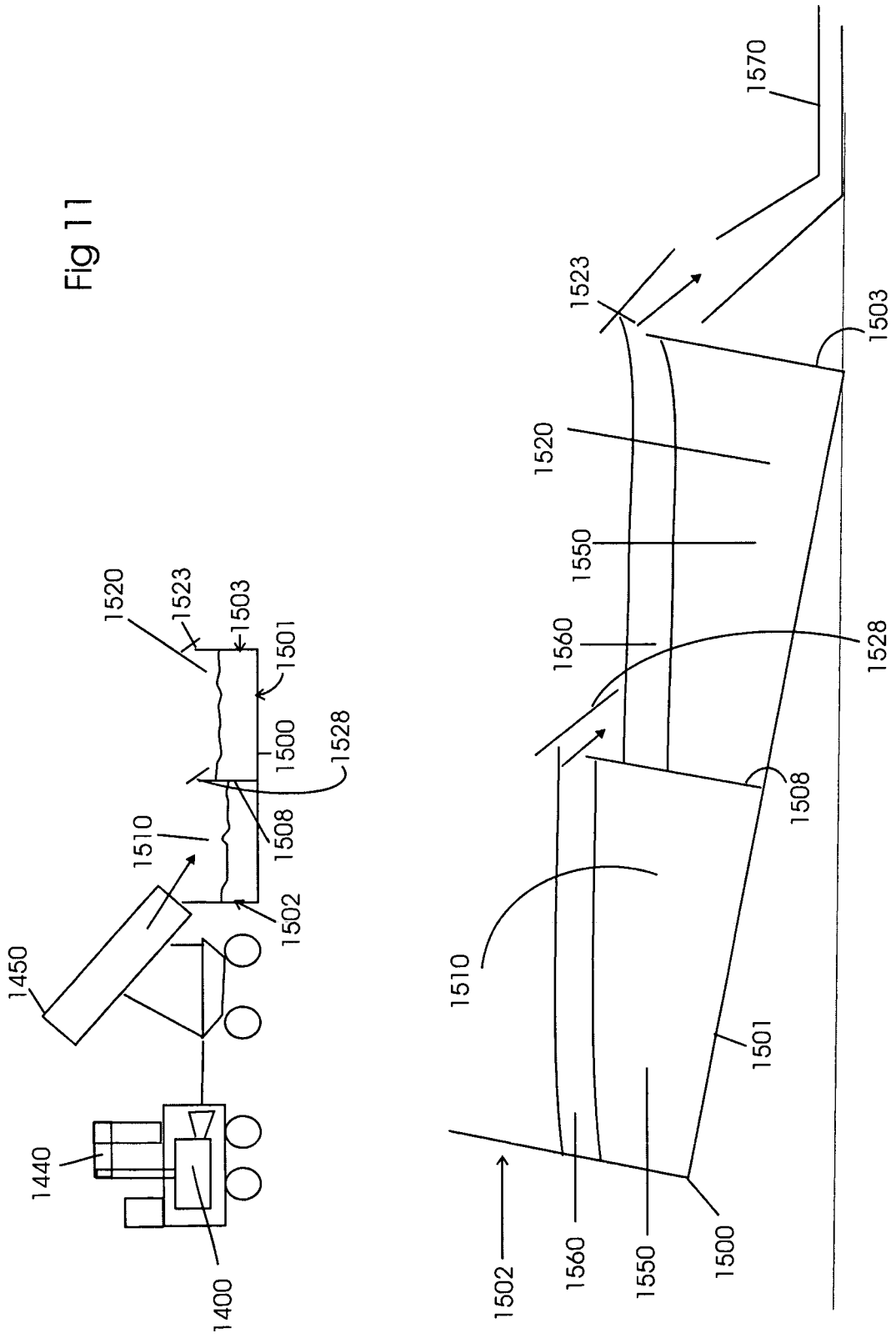
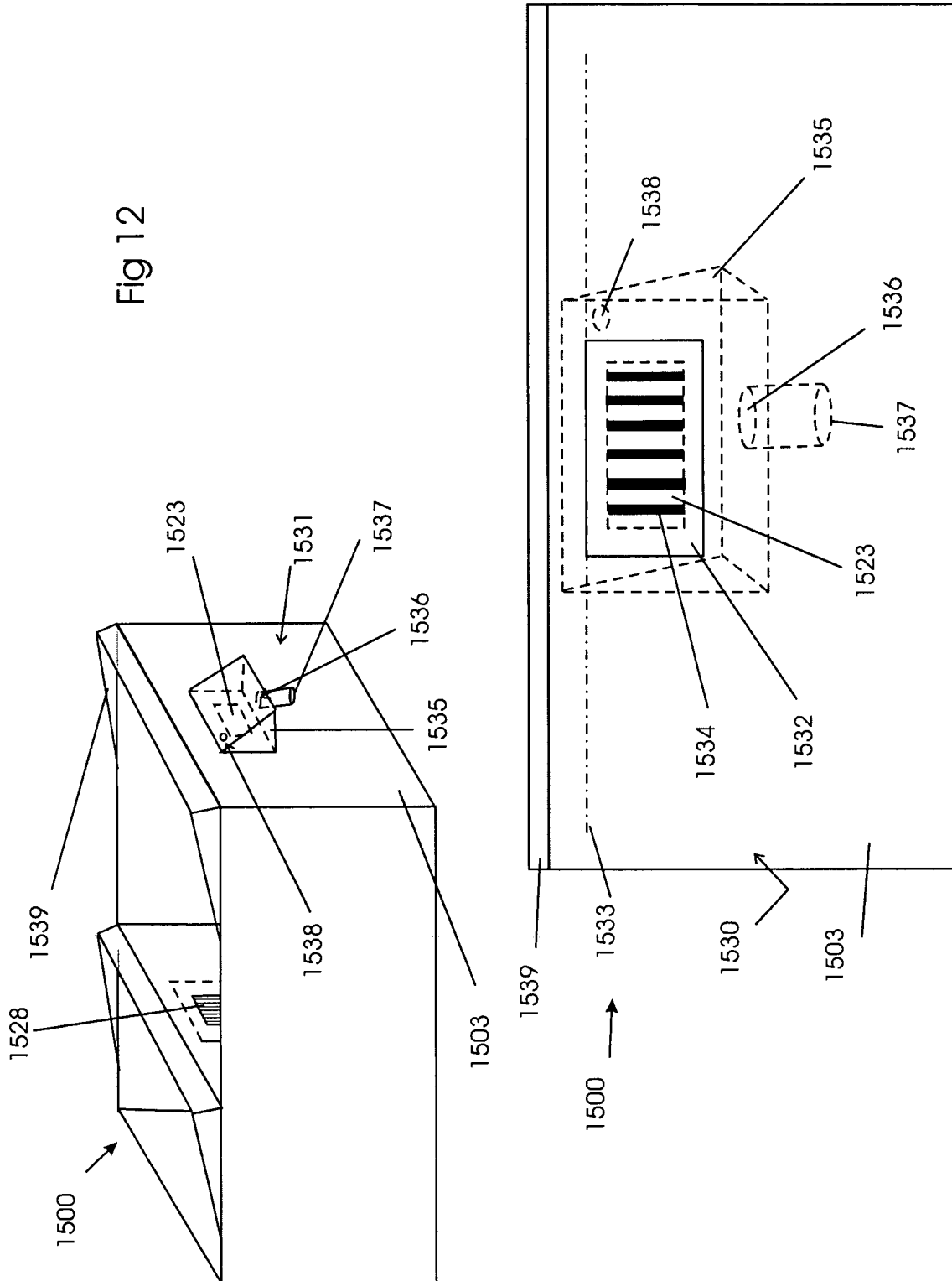

Fig 12



REFERENCES CITED IN THE DESCRIPTION

This list of references cited by the applicant is for the reader's convenience only. It does not form part of the European patent document. Even though great care has been taken in compiling the references, errors or omissions cannot be excluded and the EPO disclaims all liability in this regard.

Patent documents cited in the description

- BE 1009679 A3 [0004]