



A. F. BEAN.  
Cooking Stove.

2 Sheets—Sheet 2.

No. 2,156.

Patented July 8, 1841.

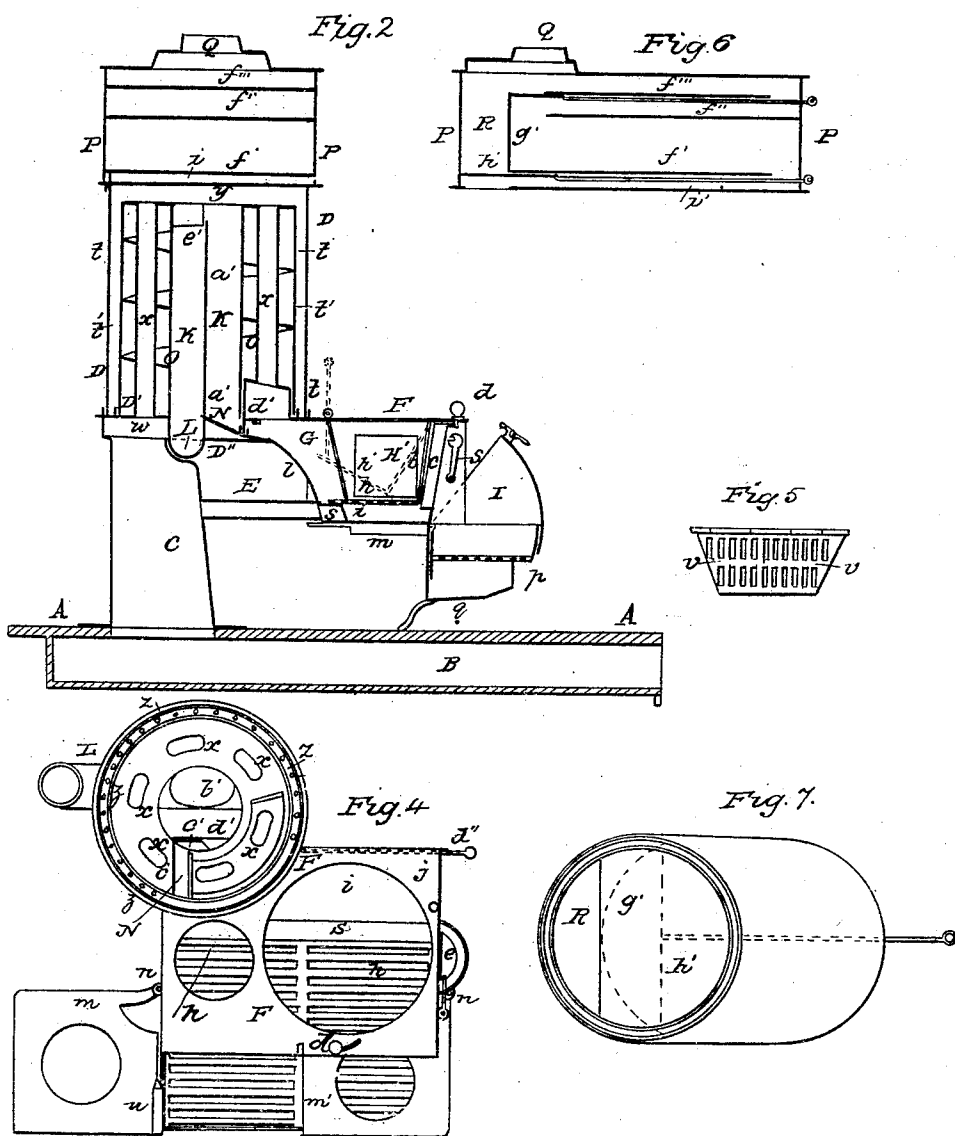

# UNITED STATES PATENT OFFICE.

ALEX. F. BEAN, OF WOODSTOCK, VERMONT.

## STOVE FOR COOKING AND HEATING.

Specification of Letters Patent No. 2,156, dated July 8, 1841.

*To all whom it may concern:*

Be it known that I, ALEXANDER F. BEAN, of Woodstock, in the county of Windsor and State of Vermont, have invented certain new and useful Improvements in the Manner of Constructing a Stove for Cooking and for Heating Apartments, which I denominate the Combined Cooking and Air-Heating Stove; and I do hereby declare that the following is a full and exact description thereof.

In the accompanying drawing Figure 1, is a perspective view of my stove, with the air-heating apparatus attached thereto.

A, A, represents a part of the floor of the apartment in which the stove is situated.

B, is a hollow trunk, or tube, through which air is to pass to supply the quantity required for combustion, and that, also, which is intended to be heated, and to be conveyed into other apartments.

Fig. 2, is a section through the stove in the line *a, b*, said section passing vertically through the center of the air-heating apparatus, and from back to front of the stove; in each of these figures, as well as in the others where like parts are seen, such parts are designated by the same letters of reference.

C, is a vertical tube, or pipe, opening into the tube B, under the floor, and serving to conduct cold air into the stove, and into the air-heating apparatus.

D, D, is the air-heating apparatus to be presently described, and into which most of the air ascending through the tube C, is to be carried.

E, is a pipe leading from C, into the back and lower part of the fire chamber, where it passes into a tube extending along said fire chamber, into which it conveys air for the support of combustion.

I will first describe the manner in which I construct and arrange the respective parts of the stove, or fire-place, and its immediate appendages, and then explain that of the air-heating apparatus, and of the oven by which it is surmounted.

F, F, is the top plate of the stove, which is pierced with openings for the reception of cooking utensils. The fire chamber has vertical grate bars *e, e*, in front; but these grate bars are made flat, and are hung upon pivots, so as to open and close in the manner of some window blinds having two pivots at their upper ends, one of which enters a slid-

ing bar; *d*, is a knob, or handle, by means of which these bars, or iron slats, may be opened, or closed, in any required degree; when closed they stand with their edges in contact; the fire chamber is by this means, with the aid of other devices to be described, converted into a close stove, and the air required for combustion is all supplied through the pipe E. In the sectional view Fig. 2, S, is the tube, or channel, into which the pipe E, leads; this tube extends along the whole length of the fire chamber to the end G, of the stove; a part of this end is shown in Fig. 3, where H, is the feeding door, and *e, e*, a valve box below it, having in it a sliding valve, or shutter, *f*, which when drawn back uncovers the mouth of the air tube S, and also uncovers the aperture *g*, through which the air that escapes through the opening S, is admitted under the lower grate bars *h*, of the fire chamber. When the shutter *f*, is closed, the supply of air from without, to the fire, is cut off. The valve box *e, e*, is represented as open at top, which is done for the purpose of showing the shutter; but it has a close fitting cover, when in use.

Fig. 4, is a top view of the stove, with the air heater removed, leaving only its seat, or base, D'. The grate *h*, upon which the fuel rests, is made to swing, so that it can be raised, and occupy the position shown by the dotted lines *h'*, Fig. 2. This is done for the purpose of dropping the coals on to the bottom plate *i*, of the fire chamber, for the purpose of covering them at night. The rod *j*, serves to raise the grate, which is hung on joint pins at the upper ends of a bar *k*, there being such a bar at each end. The back plate *l*, of the fire chamber is curved, as shown in the drawing.

The hearth of the stove is divided into two sections *m, m'*, which are made to swing and thus to uncover the grate bars in the sunk hearth, as in Chace's, and some other stoves; but it differs from them in having the joints *n, n*, of the swinging hearth so arranged as to allow the two sections to swing entirely back so as to stand under, and behind, the back plate of the fire chamber, thus removing them entirely out of the way. The bars *o, o*, under the swinging hearth, are to sustain coals for broiling, &c., air being admitted under these bars through openings *p*, in the sunk part of the hearth,

this arrangement being similar to that in the hearths of some other stoves. I make the sunk part of the hearth deeper than usual, as shown by the form of its bottom plate *q, q*. A tin reflector *I, I*, such as is commonly used with tin kitchens, is made to turn down under the bottom plate *q, q*, of the sunk hearth; in Fig. 2, this reflector is shown as partially raised; when entirely so, it closes the front of the fire place; *r*, is the joint pin upon which it turns at one end, there being a similar joint at the other end. To sustain a spit for roasting, there are two drop pieces, one of which is shown at *s*, turned up, and the other at *t*, turned down.

I leave an opening *J*, in the front of the fire chamber, which opening is entirely closed by two projecting pieces *u*, one on each section of the swinging hearth; that is, when the two parts are in the position of *m'*; when the operation of roasting is going on, and it is desired to close this opening so as to prevent coals from falling out, a hinged grated piece *v, v*, seen in part in Fig. 1, and separately in Fig. 5, is turned up; when this is turned down, coals may be drawn readily from the fire chamber on to the bars *o, o*, and a free passage to vapors is given into the fire chamber. In Fig. 1, *v, v*, is shown as turned down within the sunk hearth. The foregoing description embraces all that is novel and essential in this part of the apparatus.

In Fig. 1, the two cylinders which I employ to form the casings of the air-heating tubes, and other parts of the air-heating apparatus are omitted in the drawing for the purpose of exhibiting the interior, but their edges are shown at *t, t*, and the space between them at *t'*. The cold air to be heated is admitted into a space *w*, between the plate *D'*, Figs. 1, 2, and 4, and the bottom plate *D''*, of the air-heater. It thence ascends through air tubes, or pipes, *x, x*, into the space *y*, at the upper end of the air-heater. Another portion ascends through the space *t'*, between the two outer cylinders, being admitted into this space through the openings, or holes, *z, z*, in the plate *D'*. The air admitted into the tubes *x, x*, and the space *t'*, is heated as it ascends, by carrying the heated air from the fire chamber up through a flue which ascends spirally from the lower to the upper end of the air heater, and through which the tubes *x, x*, pass. The smoke and heated air which pass through this spiral flue, descend through a center flue, around which the spiral flue winds, and find their way to the smoke, or exit, pipe.

*K, K*, is the central flue, which is divided into two semi-cylindrical flues by a partition *a', a'*, extending from its lower, nearly to its upper end. The opening *b'*, on one side of this partition, leads into the smoke, or exit, pipe *L*, which passes under the bot-

tom plate of the air heater; the opening *c'*, communicates with the fire chamber when a valve, or shutter, *d'*, is withdrawn, and in this case the draft from the fire passes directly up on one side of the partition *a'*, *a'*, over its top, and down on the other side, to the stove pipe, as indicated by the arrows in Fig. 2; the rod *d''*, serves to move the valve *d'*; the air-heating apparatus, when the valve *d'* is open, is not in operation, the heated air from the fire not being directed along the spiral flue.

*O, O*, Figs. 1, and 2, is the spiral partition, or plate, which divides this portion of the air-heater so as to constitute it a spiral flue. When the opening covered by the valve *d'*, is closed, the draft from the fire passes into the spiral flue through the throat *M*, of the fire chamber which leads to the opening *N*, in the lower part of said flue. The heated air ascending through this flue will heat that contained in the pipes, or tubes, *x, x*, and that contained in the space *t'*, the whole of which will ascend into the space *y*, at the upper end of the air-heating apparatus. At the upper end of the spiral flue there is an opening *e'*, into the central flue *K, K*, down which flue the draft passes to the exit pipe *L*.

*P, P*, is an oven, situated on the top of the air heating apparatus, and so constructed as that the heated air may be passed into, and through, it, traversing along under and over the respective shelves contained within it; and being also furnished with valves, or shutters, by which the heated air may be excluded from the oven, and be made to pass up at its rear end, without entering the part destined for baking. The heated air is to escape from this apparatus through an opening *Q*, on the upper side of this oven, whence it may be conducted by tubes wherever it may be wanted. Fig. 6, is a vertical section along the oven *P, P*; the articles to be baked are to be placed upon the bottom plate *f'*, or upon the shelves *f'', f'''*.

*R*, is a space formed by a vertical partition *g'*, at the rear end of the oven, through which space the heated air may be made to pass, when not required for baking. A shutter *h'*, is extended across, and serves to close, this space, just below the bottom *f'*, when the heated air is to be made to pass through the oven; this shutter, as represented, closes the space *R*, and the heated air will then pass along the flue space *i'*, under *f'*, thence up through an opening at the front end of *f'*, under *f''*, and up through an opening at its rear end, then forward under *f'''*, and back to an opening at its rear end, which opening may be closed by a sliding shutter, as seen in the drawing. The number of shelves in this oven may be varied, the respective openings being made to correspond therewith. Fig. 7, is a view of the under

side of the oven, showing the opening into the space R, the shutter which serves to close it being shown in dotted lines.

The uniform practice in forming stoves 5 pipes is to make them cylindrical, excepting where it is intended to connect two pipes of different sizes, for which purpose they are often made conical; but I have satisfactorily proved that such pipes ought to go on 10 gradually enlarging from the end at which they are connected with the stove, until they enter a chimney, or otherwise terminate at their discharge end. By this manner of construction the draft is uniformly rendered 15 more free; and this appears to result from the air requiring a larger space to move in, as its movement becomes more slow; whatever may be the theory, however, upon which this fact is to be explained, the fact 20 itself I have sufficiently well established by experiment.

Having thus, fully explained and set forth the nature, construction, and operation, of my combined, cooking, and air heating stove, 25 what I claim therein as new, and desire to secure by Letters Patent, is, as follows.

1. I claim the manner of constructing the swinging hearth, so that the two sections thereof may both be turned entirely back, 30 under and behind the back plate of the stove; and so that each section of it shall have on it a plate, or piece, *v*, so formed that when in place these two pieces will cover, and entirely close, the opening J, 35 situated beneath and between the vertical grate bars, and leading into the fire chamber; by which device, when the vertical grate bars are also closed, the fire chamber will become that of a close stove, and must receive its supply of air from without the 40 room, in the manner set forth.

2. I claim the mode in which I have combined a tin reflector with my stove by hinging the same, or causing it to work upon joint 45 pins, in such manner as that it may be turned up, and will, in combination with the sunk hearth, entirely inclose the opening in front of the stove, and that when turned down, it will pass beneath the sunk hearth 50 and be entirely out of the way.

3. I claim the manner of constructing the vertical grate bars in front of the fire, so that they shall consist of flat plates, or slats, hung upon pivots, and be capable of 55 being simultaneously and entirely closed by bringing them into the same plane with each other; in the manner set forth.

4. I claim the placing of the hinged, grated piece *v, v*, so that it may be turned up to inclose, in part, the space J, when necessary, and thus to prevent the falling of coals 60 from the fire chamber; and which grated piece may be turned down, so as to be received within the sunken hearth.

5. I claim the constructing of the grate 65 below the fire, and which supports the fuel in the fire chamber, so that it may be raised up, and throw the fuel upon the dead plate below it, for the purpose of being covered to preserve it in a state of ignition. 70

6. I claim the manner of arranging the parts concerned in supplying air to the fuel, when the front of the stove is inclosed; said arrangement consisting of the tube, or pipe, E, the air tube S, extending along the lower 75 and hind part of the chamber of combustion, and the device by which it is governed at one end by a sliding shutter; the whole being combined, and operating substantially as set forth. 80

7. I claim the manner of constructing and combining the respective parts of the air-heating apparatus, substantially as set forth; the said apparatus consisting, mainly, of two cylinders with a space between them, inclosing 85 within them a spiral flue for the passage of heated air from the fire, through which flue pass a number of vertical air tubes, which are supplied with cold air from without the apartment, as is also the space between 90 the two inclosing cylinders, the same operating by an arrangement of parts such as is herein made known, and represented; there being in the center of said air-heater, a descending flue, for conducting the smoke, 95 &c., to the exit pipe, and an arrangement, such as herein set forth, for allowing the heated air from the fire to pass directly to the exit pipe, without entering the spiral flue. 100

8. I claim the manner of constructing the oven above the air heater, as set forth, so that the heated air may be passed back and forth through it when baking is to be effected, or may be made to pass directly up 105 into distribution tubes without entering the oven; this being effected by an arrangement of parts substantially the same with that herein set forth.

ALEXANDER F. BEAN.

Witnesses:

THOS. P. JONES,  
JOS. C. ANDREWS.