

March 14, 1961

D. C. KRAMMES

2,974,345

COLLAPSIBLE SUPPORT FOR AN AMBULATORY APPLIANCE

Filed Aug. 8, 1958

2 Sheets-Sheet 1

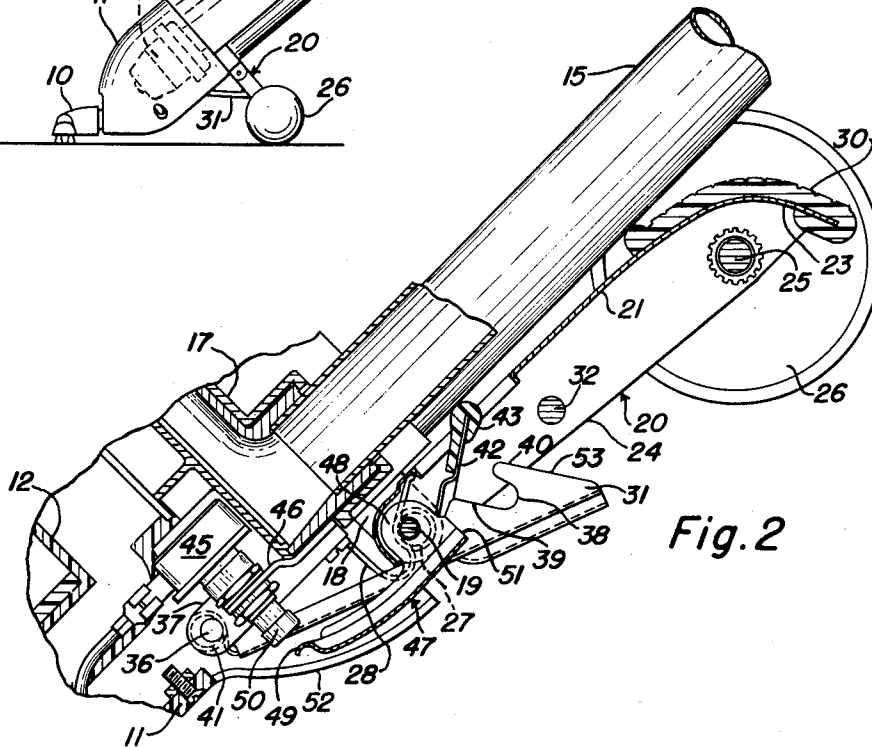
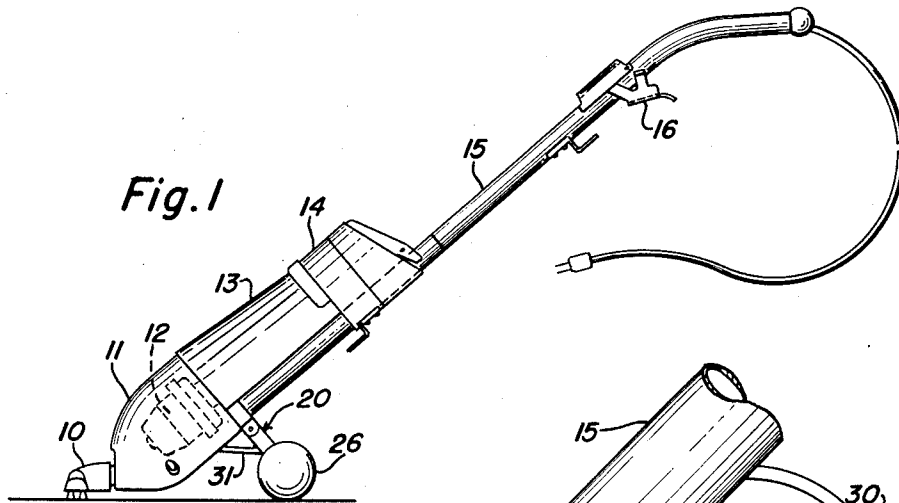

March 14, 1961

D. C. KRAMMES

2,974,345

COLLAPSIBLE SUPPORT FOR AN AMBULATORY APPLIANCE

Filed Aug. 8, 1958

2 Sheets-Sheet 2

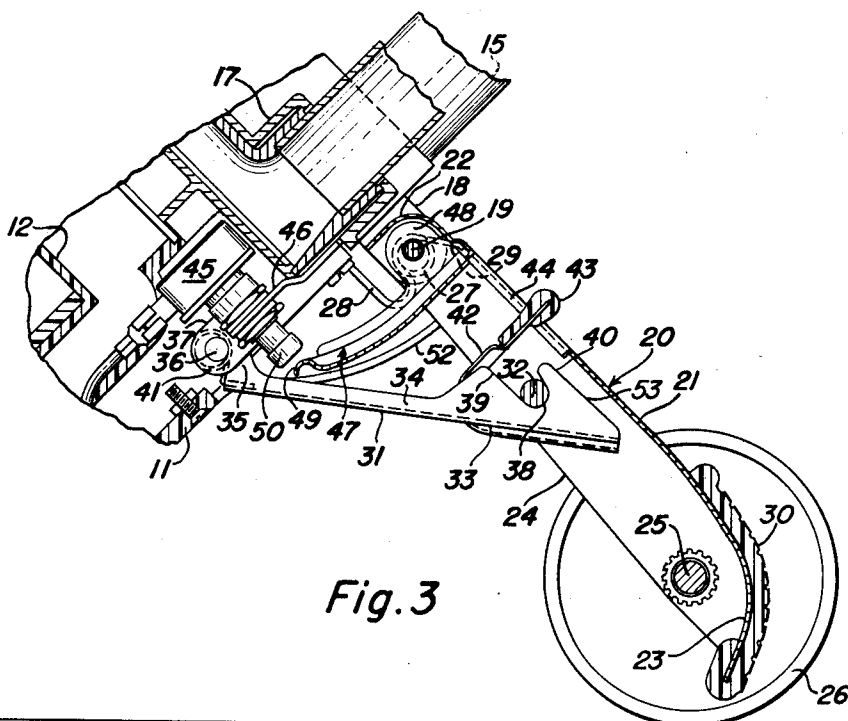

Fig. 3

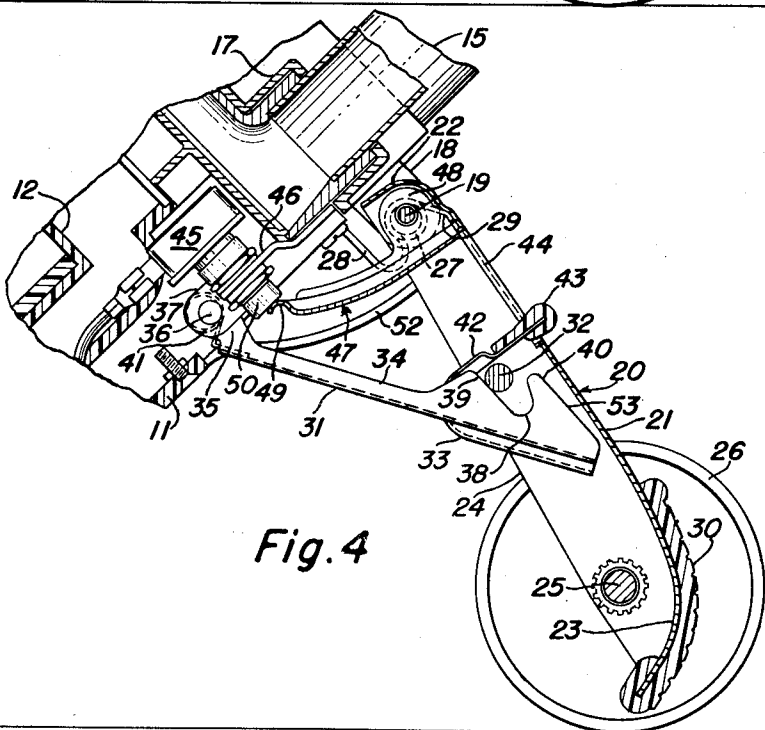

Fig. 4

1

2,974,345

COLLAPSIBLE SUPPORT FOR AN AMBULATORY APPLIANCE

Don C. Krammes, Canton, Ohio, assignor to The Hoover Company, North Canton, Ohio, a corporation of Ohio

Filed Aug. 8, 1958, Ser. No. 754,033

6 Claims. (Cl. 15-328)

The present invention relates to a wheeled support for an ambulatory appliance and more particularly to a support movable to collapsed and projected positions relative to the body of the appliance.

An object of the invention is to provide an appliance with a motor switch controlled by movement of the support toward its projected position. Another object is to provide an appliance with a latching device to maintain the support in projected position, and latch releasing means actuated by applying a force in the same direction as movement of the support to its projected position for disconnecting the latching device and permit movement of the support in a reverse direction to its collapsed position. Another object is to provide the aforesaid appliance with a motor switch controlled by movement of the support in the same direction to its projected position relative to the appliance. Other objects and advantages of the invention will become apparent from the following description and drawings wherein:

Figure 1 is a side elevational view of a scrubbing appliance embodying the invention,

Figure 2 is a sectional view of the support in collapsed position relative to the appliance,

Figure 3 is a sectional view showing the support locked in projected position, and

Figure 4 is a similar view but showing the support in position to operate the switch on the appliance.

The invention herein disclosed is embodied in a surface cleaning appliance comprising a nozzle 10, a housing 11 enclosing a motor-fan unit 12, a liquid container 13, a combined separator and non-return water valve 14, and a handle 15 on which is mounted a control lever 16, all of which are fully described and claimed in my co-pending application Serial No. 754,093, filed concurrently herewith.

A casting 17 forms part of the body of the appliance and is provided with a pair of rearwardly projecting lugs 18 in which is mounted a pin 19 rotatably supporting a wheeled frame 20. The frame 20 has a top wall 21, depending front wall 22, an arcuate rear wall 23 and a pair of spaced side walls 24. Supported in the side walls 24 of the frame 20 adjacent the rear wall 23 is a shaft 25 on the opposite ends of which are mounted a supporting wheel 26. A torsion spring 27 is arranged about the pivot pin 19 and has one end 28 formed in substantially U-shape to clear the frame front wall 22 and is secured to the body of the appliance, the other end 29 of the spring bears against the frame top wall 21, and the spring 27 at all times biases the frame 20 in a counterclockwise direction to its collapsed position relative to the appliance as shown in Figure 2. The rear wall 23 of the supporting frame 20 is provided with a pad 30 to receive a force applied by the operator's foot to move the supporting frame from its collapsed position in Figure 2 to the projected position in Figure 3.

A latching device is provided to lock the supporting frame 20 in projected position relative to the appliance and includes a latch lever 31 and a latch receiving rod

2

32, the latter being mounted on the spaced side walls 24 of the supporting frame 20. The latch lever 31 has a panel 33 from which upwardly projects spaced side walls 34 each formed at their inner end with an ear 35 pivotally supported on a pin 36 mounted in a pair of lugs 37 secured to the casting 17. The forward end of each side wall 34 is provided with a substantially U-shaped recess 38, the lower leg 39 of which extends beyond the upper leg 40 and the recesses 38 are adapted to receive the latch rod 32. A torsion spring 41 is arranged about the pivot pin 36 and at all times urges the latch lever 31 to rotate in a counterclockwise direction to its collapsed position shown in Figure 2.

Upstanding from the panel 33 is a latch releasing member 42 formed by cutting out a portion of the panel 33 and bending the portion inwardly. The releasing member 42 is positioned inwardly of the ends of the lower arms 39 of the recesses 38 to prevent the latch rod 32 sliding off the ends of the arms 39. The upper end of the member 42 is provided with a pad 43 which projects through an opening 44 in the top wall of the supporting frame 20. The pad 43 is adapted to receive a downward force from the operator's foot to disengage the recesses 38 from the latch rod 32 whereby the wheel supporting frame 20 is rotated by the torsion spring 27 to its collapsed position.

A push-push switch 45 for the motor of the motor-fan unit 12 is mounted on a bracket 46 secured to the casting 17, and the switch is arranged within the housing 12 at one side of the latch lever 31. An operating lever 47 for the switch 45 is provided at one end with a pair of spaced ears 48 which are loosely mounted on the pivot pin 19 and the other end of the lever has a portion 49 adapted to engage the switch plunger 50. The pivoted end of the lever 47 has a straight surface 51 which is engaged by the top wall 21 of the supporting frame 20 to rotate the lever 47 against the plunger 50 and depress the latter to control operation of the switch as shown in Figure 4. The switch lever 47 pivots freely on the pin 19 and its rotation in a counterclockwise direction is limited by engaging a projecting wall 52 of the housing 11.

When it is desired to propel the appliance over a surface to be cleaned the wheel frame 20 is moved from its collapsed position in Figure 2 to its projected position in Figure 3. In order to shift the frame 20 to its projected position the operator places his foot on the pad 30 and exerts a downward force which moves the frame 20 in a clockwise direction about the pivot pin 19 against the force of the torsion spring 27. During clockwise rotation of the frame 20 the latch rod 32 engages the upper surfaces 53 of the latch lever 31 and rotates the latter about its pivot 36, and the pivotal axis of the frame 20 being offset with respect to the pivotal axis of the latch lever 31 causes the latch rod to move out of engagement with the latch lever surfaces 53 onto the lower arms 39 of the latch recesses 38 at which time the operator removes his foot from the pad 30 and then torsion spring 41 rotates the latch lever 31 in a counterclockwise direction to seat the latch rod 32 in the recesses 38 and lock the frame 20 in projected position relative to the appliance as shown in Figure 3.

The motor of the motor-fan unit 12 is energized by the operator applying foot pressure on the frame pad 30 to move the frame in a clockwise direction from the projected position in Figure 3 to the switch operating position in Figure 4. The additional clockwise rotation of the frame 20 causes the top wall 21 of the frame to abut the end 51 of the switch lever 47 and rotates the latter clockwise to move the end 49 which depresses the plunger 50 and operates the switch 45 to energize the motor. During rotation of the frame 20 for closing the switch 45 the

3

latch rod 32 is displaced along the lower arms 39 of the recesses 38, but is limited in such movement by engaging the latch release lever 42, as shown in Figure 4. The latch lever 31 maintains the latch rod 32 in operative position for re-engagement with the walls of the recesses 38 when the force applied to the pad 30 is removed allowing the torsion spring 41 to rotate the latch lever 31 counterclockwise to arrange the latch rod 32 in locked position in the recesses 38 and thereby maintain the frame 20 in projected position. The switch 45 is operated to its open circuited position by repeating the same function described in connection with moving the switch to its motor energizing position.

If desired the switch 45 may be operated by one continuous clockwise rotation of the frame 20 from collapsed position to the position shown in Figure 4 and thereafter upon removing the force applied to the pad 30 the latch rod 32 will be seated in the recesses 38 by counterclockwise rotation of the latch lever 31 to lock the frame 20 in projected position.

In order to return the supporting frame 20 to its collapsed position the operator's foot applies a force on the pad 43 of the latch release member 42 to rotate the latch lever 31 in a clockwise direction. Clockwise rotation of the latch member 31 moves the recesses 38 out of engagement with the latch rod 32 and since the pad 43 projects above the supporting frame 20 the force applied thereto is not placed directly on the supporting frame 20, whereby the torsion spring 27 begins to rotate the frame 20 in a counterclockwise direction and upon removal of the operator's foot from the pad 43 the torsion spring 27 is free to continue rotating the supporting frame 20 to its collapsed position shown in Figure 2. When the latch recesses 38 are disengaged from the latch rod 32 and the force is removed from the pad 43 the torsion spring 41 returns the latch lever 31 to its collapsed position shown in Figure 2 and such movement is limited by the pad 43 abutting the body of the appliance.

While I have shown and described but one embodiment of my invention, it is to be understood that this embodiment is to be taken as illustrative only and not in a limiting sense. I do not wish to be limited to the particular structure shown and described but to include all equivalent variations except as limited by the scope of the claims.

I claim:

1. In an ambulatory appliance of the type to be propelled along a surface, comprising a body, a motor for the appliance mounted on said body, a frame pivotally mounted on said body for movement between collapsed

4

and projected positions relative to said body, said frame adapted to receive an operator applied force to move said frame to its said projected position, wheel means on said frame for supporting the appliance on a surface along which the appliance is propelled when said frame is in its projected position, a switch mounted on said body and in circuit with said motor, and switch operating means movable by said frame to close said switch upon movement of said frame beyond said projected position.

2. An appliance as described in claim 1, and means mounting said switch operating means relative to said frame for movement of said switch operating means in the same direction as said frame during movement of the latter from said collapsed position to beyond said projected position.

3. An appliance as described in claim 1, latch receiving means on said frame, and latch means mounted on said body for connection with said latch receiving means upon movement of said frame to its projected position to thereby lock said frame in projected position relative to said body.

4. An appliance as described in claim 3, and resilient means biasing said latch means into said connection with said latch receiving means upon movement of said frame to its projected position.

5. An appliance as described in claim 3, and releasing means on said latch means for disconnecting the latter from said latch receiving means whereby said frame can be returned to its collapsed position.

6. An appliance as described in claim 3, and means on said frame for receiving a force applied in one direction by an operator to effect said movement of said frame to its projected position, and releasing means on said latch means positioned with respect to said frame to receive a force by the operator applied in said one direction to disconnect said latch means from said latch receiving means for return of said frame to its collapsed position.

References Cited in the file of this patent

UNITED STATES PATENTS

1,508,134	Barnett	Sept. 9, 1924
1,687,283	Deutscher	Oct. 9, 1928
2,079,293	Kirby	May 4, 1937
2,289,711	Kirby	July 14, 1942
2,420,066	Conway	May 6, 1947
2,478,995	Woodman	Aug. 16, 1949
2,590,152	Buckey	Mar. 25, 1952
2,675,246	Arones	Apr. 13, 1954
2,688,671	Segesman	Sept. 7, 1954