



HU000035175T2

(19) **HU**(11) Lajstromszám: **E 035 175**(13) **T2****MAGYARORSZÁG**
Szellemi Tulajdon Nemzeti Hivatala**EURÓPAI SZABADALOM**
SZÖVEGÉNEK FORDÍTÁSA

(21) Magyar ügyszám: **E 13 704055** (51) Int. Cl.: **B65D 19/06** (2006.01)
(22) A bejelentés napja: **2013. 02. 06.** **B65D 85/48** (2006.01)
B65D 19/42 (2006.01)
(96) Az európai bejelentés bejelentési száma: **B62B 3/00** (2006.01)
EP 20130704055
(97) Az európai bejelentés közzétételi adatai: (86) A nemzetközi (PCT) bejelentési szám:
EP 2812256 A1 **2013. 08. 15.** **PCT/EP 13/052288**
(97) Az európai szabadalom megadásának meghirdetési adatai: (87) A nemzetközi közzétételi szám:
EP 2812256 B1 **2017. 04. 12.** **WO 13117569**

(30) Elsőbbségi adatok: 201202328 2012. 02. 10. GB	(73) Jogosult(ak): Belron Hungary Kft-Zug Branch, 6300 Zug (CH)
(72) Feltaláló(k): LOPEZ, Alain, E-08100 Mollet del Valles (ES) BOFILL, Enoc, E-08100 Mollet del Valles (ES)	(74) Képviselő: Danubia Szabadalmi és Jogi Iroda Kft., Budapest

(54) **Konténer**

Az európai szabadalom ellen, megadásának az Európai Szabadalmi Közlönyben való meghirdetésétől számított kilenc hónapon belül, felszólalást lehet benyújtani az Európai Szabadalmi Hivatalnál. (Európai Szabadalmi Egyezmény 99. cikk(1))

A fordítást a szabadalmat az 1995. évi XXXIII. törvény 84/H. §-a szerint nyújtotta be. A fordítás tartalmi helyességét a Szellemi Tulajdon Nemzeti Hivatala nem vizsgálta.

(19)



(11)

EP 2 812 256 B1

(12)

EUROPEAN PATENT SPECIFICATION

(45) Date of publication and mention
of the grant of the patent:
12.04.2017 Bulletin 2017/15

(51) Int Cl.:
B65D 19/06 (2006.01) **B65D 19/42** (2006.01)
B62B 3/00 (2006.01) **B65D 85/48** (2006.01)

(21) Application number: **13704055.6**

(86) International application number:
PCT/EP2013/052288

(22) Date of filing: **06.02.2013**

(87) International publication number:
WO 2013/117569 (15.08.2013 Gazette 2013/33)

(54) **CONTAINER**

BEHÄLTER

CONTENEUR

(84) Designated Contracting States:
**AL AT BE BG CH CY CZ DE DK EE ES FI FR GB
GR HR HU IE IS IT LI LT LU LV MC MK MT NL NO
PL PT RO RS SE SI SK SM TR**
Designated Extension States:
ME

(30) Priority: **10.02.2012 GB 201202328**

(43) Date of publication of application:
17.12.2014 Bulletin 2014/51

(73) Proprietor: **Belron Hungary Kft-Zug Branch
6300 Zug (CH)**

(72) Inventors:
• **LOPEZ, Alain**
E-08100 Mollet del Valles (ES)

• **BOFILL, Enoc**
E-08100 Mollet del Valles (ES)

(74) Representative: **Davies, Gregory Mark**
Urquhart-Dykes & Lord LLP
7th Floor
Churchill House
Churchill Way
Cardiff CF10 2HH (GB)

(56) References cited:
EP-A2- 2 042 403 **EP-B1- 1 737 764**
BE-A1- 792 929 **GB-A- 2 189 198**
GB-A- 2 190 895 **GB-A- 2 480 673**
US-A1- 2008 110 905 **US-A1- 2008 265 538**
US-A1- 2010 109 268

EP 2 812 256 B1

Note: Within nine months of the publication of the mention of the grant of the European patent in the European Patent Bulletin, any person may give notice to the European Patent Office of opposition to that patent, in accordance with the Implementing Regulations. Notice of opposition shall not be deemed to have been filed until the opposition fee has been paid. (Art. 99(1) European Patent Convention).

Description

[0001] The present invention relates to a container, and in particular to a container suited for the transportation and/or storage of sheet items, particularly fragile delicate or non-uniform shape items such as, for example different sized vehicle windscreens or the like.

[0002] Prior art containers are disclosed in for example EP1737764 and GB2480673. Such containers are particularly suited to shipping and storage of vehicle windscreens. Typically such containers are loaded with windscreens at a large centralised distribution centre and then shipped to a local depot or workshop for fitting as replacement windscreens.

[0003] Demand at the large centralised distribution centre is high and large containers are best suited to efficient loading. Containers are moved around the distribution centre between various locations where the appropriate selection of windscreens is 'picked' to demand, dependant upon the requirement at the local depot or workshop. Large containers full of windscreens selected to order can be easily accommodated at larger busier local depots or branches. However for smaller, less busy local depots or branches it would be preferable for smaller containers loaded with fewer windscreens to be shipped. An obvious solution would be for larger containers to be loaded with fewer containers. This would provide for inefficiency at the centralised distribution centre.

[0004] An improved container and handling or distribution procedure have now been devised.

[0005] According to a first aspect of the present invention, there is provided a container for transportation and/or storage of items, wherein the container is provided with under-slung tine guides for aiding lifting of the container, and also rotatable support members upon which the container may be moved and with securing means for like containers positioned in side by side relationship to be releasably secured to one another, such that the tine guides on adjacently secured containers are co-aligned with one another and the securing means comprises a securing element mounted on one of the containers and deployable from a stowed position to a deployed position for securing the containers.

[0006] According to a further aspect, the invention provides a method of material handling, the method comprising securing together a plurality of containers in side by side relationship and moving/lifting the containers together between a plurality of picking or loading locations; following loading of the containers with at least some material at the distributed picking/loading locations, disengaging and separating the containers for enabling onward transportation in separation.

[0007] Typically the container is rectangular in footprint, being narrow of width and has a relatively long length. When handling in side by side relationship, the long sides of the containers are positioned adjacent one another.

[0008] Typically, access for placing items into the con-

tainer or removing items from the container is provided through an upper portion of the container. For example the container may have an open (or openable) top.

[0009] The container may comprise a frame structure, typically defining a base and a periphery. Typically upright corner frame posts are provided.

[0010] It is preferred that the securing means is arranged to secure frame members of side by side adjacent containers, for example by means of clamping.

[0011] Beneficially the securing means is arranged to secure like containers positioned in side by side relationship such that they can be lifted together. The containers clamped together can therefore be lifted in unison, for example at a picking location/station. The securing means comprises a securing element mounted or tethered to the container. This provides that separate securing elements for example free clamps or bolts are not required. The securing element is deployable from a stowed position to a deployed position for securing to an adjacent positioned like container. In the stowed position it is preferred that the securing element lies contiguous with a frame member of the container frame. This ensures that it does not stand proud which would make the securing element susceptible to damage.

[0012] In one embodiment, the securing element is pivotally mounted to or hinged to the container frame, in order to be pivoted from the stowed to the deployed position.

[0013] It is preferred that the securing element is configured for mating securing engagement with a complementary formation provided on the side by side positioned container. In one embodiment the securing element comprises a retractable bolt or pin (preferably spring biased/loaded) for retractable engagement with a bolt or pin receiving aperture provided on the frame of the side by side positioned like container. The securing element preferably includes a flange or abutment which is moved into position to capture the upright corner post of the container frame of the side by side positioned like container.

[0014] It is preferred that a first securing means is provided proximate the base of the container.

[0015] It is preferred that a second securing means is provided proximate the top of the container.

[0016] Beneficially, the under slung tine guides are configured for receiving lifting tines of lifting apparatus, such as the lifting tines of a fork lift device. Typically two tine guides are spaced on the long side of the container and typically provided close to the corners of the container.

[0017] It is preferred that a respective rotatable support member is provided for a respective tine guide and positioned adjacently thereto.

[0018] Typically, the respective tine guide is positioned outwardly of the respective rotatable support member. In a preferred embodiment, the tine guide includes a bracket formation or bracket mounting for the rotatable support member.

[0019] The rotatable support members are arranged to ensure that the tine guides are positioned clear above the floor surface enabling the container to be movably supported on the rotatable members.

[0020] Typically, the rotatable support members comprise wheels or casters.

[0021] Typically, the container has upright corner posts which are adjustable in height.

[0022] Typically, the container has upright corner posts which are provided with stacking formations enabling like containers to be stacked one on top of another.

[0023] In a preferred embodiment, two pairs of opposed positioned tine guides are provided, a pair on each opposed side of the container.

[0024] It is preferred that a securing assembly is provided for the container to ensure that when windscreens are stacked in the container they are secured with respect to the container.

[0025] The securing assembly may comprise a post or other upright assembly to which a securing belt may be fixed, which can be tightened around the windscreens to ensure they are tightly packed. Typically packing material is interleaved between the windscreens when secured in the container. An exemplary securing assembly is disclosed in EP1737764.

[0026] The invention will now be described in a specific embodiment, by way of example only and with reference to the accompanying drawings, in which:

Figure 1 is a perspective view of a container suited for transportation and/or storage of sheet items such as windscreens, in accordance with the invention:

Figure 2 is a detailed view of part of the container of figure 1

Figure 3 is a side view of the portion of the container of figure 2

Figure 4 is a perspective view of the container with the securing element in a partially deployed position

Figure 5 is a detailed view of the partially deployed securing element of figure 4

Figure 6 is a detailed component view of the securing element

Figure 7 is an end view of the container with the securing element in the deployed position

Figure 8 is an end view of two containers arranged in side by side relationship and clamped using the securing element

Figure 9 is a detailed view of the arrangement shown in figure 8 showing the clamping of the containers in a side by side relationship

Figure 10 is a perspective view of the secondary securing means in accordance with the container of the invention.

[0027] Referring to the drawings in figure 1 there is shown a container 1 in perspective view. The container 1 is of frame construction comprising four corner posts 2, 3, 4, 5 elongate side members 31 at the base of the container connecting the corner posts and end frame elements 18 at the base. End stays 32, 33 are also provided connecting corner posts 4, 5 and 2, 3 at opposed ends of the container. Along the back of the container there is a higher longitudinal frame element 6 connecting corner posts 5, 3 at opposed ends of the container. A forward longitudinal frame element 7 connects the front corner posts 2, 4. The container is of significantly narrower width than length as can be seen clearly in the diagrams. Side panels 40, 41, 42, 43, 44 are mounted to the frame of the container 1. In certain embodiments one or more of the panels may be omitted.

[0028] The corner posts 2, 3, 4, 5 are extendable in length and provided at their uppermost extent with plug formations 13. The upper end portion of each corner post 2, 3, 4, 5 is telescopically received to permit extension of the overall length. A locking catch mechanism 60 (best shown in figure 10) is provided to secure the telescopically received end in the non extended position with respect to the respective corner post 2, 3, 4, 5.

[0029] At each respective foot of the corner posts 2, 3, 4, 5 a respective end stop socket 12 is provided. The end stop sockets 12 are shaped in dimension to matingly engage with (receive) the plug 13. Therefore like containers 1 can be stacked on top of each other with the plugs 13 engaging in the sockets 12 securely locating the like containers 1 stacked on top of each other.

[0030] A securing assembly 14 is provided for the container to ensure that when windscreens are stacked in the container a securing belt fixed to the securing arrangement can be tightened around the windscreens to ensure they are tightly packed. Typically packing material is interleaved between the windscreens when secured in the container. A similar securing assembly is disclosed in EP1737764.

[0031] The base of the container is provided with under slung casters 10, 11 and also under slung tine guides 8, 9. Four tine guides 8, 9 are provided two at the front edge of the container closely adjacent the corner posts 2, 3, 4, 5 and two at the rear of the container aligned with the two tine guides at the front of the container. The casters 10, 11 are mounted inwardly of the tine guides. The tine guides include a limb extension 8b, 9b which provides a mounting bracket for the casters 10, 11 respectively. The arrangement is such that the container 1 can be moved on the casters 10, 11 with the tine guides 8, 9 standing clear of the floor surface. The tine guides 8, 9 provide for receiving the tines of forklift apparatus such as forklift trucks that are commonly found in distribution centres.

[0032] The container 1 is provided at each opposed

longitudinal end, with a securing device 17 proximate the base of the container for securing side by side positioned like containers (1a, 1b- see figures 8 and 9) to one and other, for example, for the purpose of container loading at a distribution centre. The side by side securing device 17 provided at each end is shown most clearly in figures 2 to 9. The arrangement comprises, as shown in figure 6, a securing element or bracket 17 having a hinge mounting 22 at the proximal end of an arm 21 of the securing element or bracket 17, which is provided at its distal end with a transversely extending flange portion 25. The flange portion 25 carries a spring loaded translationally movable retractable pin 23 which is mounted in a boss 26 and provided with an actuating pull ring 24. Pulling on the pull ring 24 in the direction of arrow A in figure 6 ensures that the pin is retracted back through the flange portion 25 of the securing element, into the boss 26.

[0033] As shown in the figures, the securing element or bracket 17 is mounted by the hinge formation 22 to the lower frame element 18 at each end of the container 1. The securing element or bracket 17 is shown in the stowed configuration in figures 2 and 3, the hinge formation 22 being mounted at the end of the frame element 18 closest to the front corner posts 2,4. Securing elements are provided at both longitudinal opposed ends of the container. In a stowed configuration the securing element or bracket 17 is held to be nesting in the recess of the frame section 18 and therefore out of harms way. In this position the securing element or bracket 17 is retained by means of a securing hook 20 which engages with the pull ring 24. By disengaging the pull ring from the hook 20 the securing element or bracket 17 can be pivoted about the hinge formation 22 from a stowed position to a deployed configuration.

[0034] In figure 5 the securing element or bracket 17 is shown partially deployed moving to the fully deployed position as shown in figures 7 to 9. In a fully deployed position the securing element or bracket 17 extends outwardly beyond the front longitudinal edge of the container and provides for securing or coupling to the rear corner post 5b of a like container positioned in side by side relationship (see figures 8 and 9). In the deployed position the flange 25 of the securing element 17 is positioned adjacent the forward facing surface of the rear corner post 5b of the adjacent container 1b. This is the configuration shown in figures 8 and 9. The pin 23 is spring loaded to be urged into engagement either with a recess or receiving aperture provided in the corner post 5b or alternatively with the far side of the corner post 5b. The securing element at the other longitudinal end of the container 1a similarly engages to couple with the rear corner post 3b. In either event the rigid securing elements/brackets 17 act to effectively and rigidly couple together the forward corner posts 2a, 2b of a first container and a respective rear post 3b, 5b of the side by side adjacent container 1b.

[0035] A secondary coupling means is provided prox-

imate the upper portion of the containers 1a 1b at both opposed longitudinal ends of the container. This arrangement is shown most clearly in figure 10. The arrangement comprises a securing catch 50 mounted on a pivot 51 on the rear corner post 3,5 at each end of the container. The forward corner posts 2, 4 are provided with a hook formation 53 within which the end finger portion 52 of the catch 50 is arranged to locate when the two adjacent containers 1a, 1b are positioned in side by side relationship. This ensures that the upper portions of the containers 1a, 1b are coupled together in addition to the primary coupling via the lower securing elements 17.

[0036] In use, the containers according to the invention provide for easy and quick coupling. This is partially due to the fact that the securing elements and couplings 17, 50 are providing proximate upper and lower portions of the container and also the fact that the securing elements and couplings are integrally mounted with the container so that separate clamps or fixing arrangements are not required.

[0037] In use, two like containers 1a, 1b are coupled to one and other using the securing means as described and the containers can be moved in unison and lifted in unison using forklift apparatus. The fork lift tines 8 provide for this. This provides for efficient and easy coupling together of pairs of like containers at the distribution centre to enable most efficient loading. The coupled containers can be lifted and moved together between the various picking locations or picking stations and containers filled as a couple with the required various shaped and sized windscreens in accordance with the contents demanded.

[0038] As mentioned earlier, demand at large centralised distribution centres is high and large containers are best suited to efficient loading. Containers are moved around the distribution centre between various locations where the appropriate selection of windscreens is 'picked' to demand, dependant upon the requirement at the local depot or workshop. When distributing to local depots or workshops for end use, large containers full of windscreens selected to order can be easily accommodated at larger busier local depots or branches. However for smaller, less busy local depots or branches it would be preferable for smaller containers loaded with fewer windscreens to be shipped. An obvious solution would be for larger containers to be loaded with fewer containers. This would provide for inefficiency at the centralised distribution centre. The present invention provides the best of both worlds in that coupled smaller containers can be handled together for loading at the distribution centre and then decoupled for onward shipping to local depots or workshops.

[0039] The containers can then be shipped from a distribution centre either coupled or more likely separately. The containers in accordance with the invention provide for separated containers to be distributed independently to different end user locations. At the end user locations the provision of the casters under slung below the base of the container, enable the containers to be easily moved

around in locations where fork lifting apparatus is not provided. Accordingly, containers in accordance with the invention provide for convenient material handling and distribution at opposite ends of the supply chain (distribution centre and local workshop). The invention has been defined specifically in respect of its utility and application to shipping of vehicle windscreens. However, it will be readily appreciated that the invention has the ability to be exploited in other situations and for other container contents.

Claims

1. A container (1) for transportation and/or storage of items, wherein:

the container is provided with under-slung tine guides (8, 9) for aiding lifting of the container, and also rotatable support members (10, 11) upon which the container may be moved and with securing means for like containers positioned in side by side relationship to be releasably secured to one another, wherein the securing means comprises a securing element (17) mounted on the container and deployable from a stowed position to a deployed position for securing like containers, **characterised in that** the tine guides (8, 9) on adjacently secured containers positioned in side by side relationship are co-aligned with one another.

2. A container according to claim 1, wherein:

access for placing items into the container or removing items from the container is provided through an upper portion of the container.

3. A container according to Claim 1 or Claim 2, wherein the container comprises a frame structure defining a base and a periphery.

4. A container according to Claim 2, wherein the securing means is arranged to secure, for example by means of clamping, frame members of side by side adjacent containers.

5. A container according to any preceding claim, wherein the securing means is arranged to secure like containers positioned in side by side relationship such that they can be lifted or moved together.

6. A container according to any preceding claim, wherein:

i) the securing element (17) is pivotally mounted or hinged to be pivoted from the stowed to the deployed position; and/or

ii) wherein the securing element (17) is configured for mating securing engagement with a complementary formation provided on the side by side positioned container.

7. A container according to any preceding claim, wherein:

i) the securing means is provided proximate the base of the container; and/or
ii) the securing means is provided proximate the top of the container.

8. A container according to any preceding claim wherein the under-slung tine guides (8, 9) are configured for receiving lifting tines of lifting apparatus.

9. A container according to claim 8, wherein a respective rotatable support member (10, 11) is provided for a respective tine guide (8, 9) and positioned adjacently thereto.

10. A container according to claim 9, wherein the respective tine guide is positioned outwardly of the respective rotatable support member.

11. A container according to claim 9 or claim 10, wherein the tine guide includes a bracket formation or bracket mounting for the rotatable support member.

12. container according to any of claims 9 to 11 wherein the rotatable support members are arranged to ensure that the tine guides are positioned clear above the floor surface enabling the container to be movably supported on the rotatable members.

13. A container according to any preceding claim, wherein:

i) the rotatable support members (10, 11) comprise wheels or casters; and/or
ii) the container has upright corner posts (2, 3, 4, 5) which are adjustable in height and include formations enabling like containers to be stacked one on top of another; and/or
iii) the container has upright corner posts (2, 3, 4, 5) which are provided with stacking formations enabling like containers to be stacked one on top of another.

14. A container according to any preceding claim, wherein;

i) two pairs of opposed positioned tine guides (8, 9) are provided, a pair on each opposed side of the container; and/or
ii) the container has a short width and a relatively long length.

15. A method of material handling, the method comprising securing together a plurality of containers (1) according to any preceding claim in side by side relationship and moving/lifting the containers together between a plurality of picking or loading locations; following loading of the containers with at least some material at the distributed picking/loading locations, disengaging and separating the containers for enabling onward transportation in separation.

Patentansprüche

1. Behälter (1) für den Transport und/oder die Lagerung von Gegenständen, wobei:

der Behälter mit unterbauten Sprossenführungen (8, 9), die das Anheben des Behälters unterstützen, und außerdem mit drehbaren Stützelementen (10, 11), auf denen der Behälter bewegt werden kann, und mit einem Sicherungsmittel für gleiche Behälter, die in nebeneinander liegender Beziehung platziert sind, um auf lösbare Weise aneinander befestigt zu werden, versehen ist, wobei das Sicherungsmittel ein Sicherungselement (17) umfasst, das an dem Behälter befestigt ist und von einer Verstaueungstellung in eine Einsatzstellung gebracht werden kann, um gleiche Behälter zu befestigen, **dadurch gekennzeichnet, dass** die Sprossenführungen (8, 9) an benachbart befestigten Behältern, die in nebeneinander liegender Beziehung platziert sind, in einer Linie miteinander ausgerichtet sind.

2. Behälter nach Anspruch 1, wobei:

ein Zugang zum Platzieren von Gegenständen in dem Behälter oder zum Entnehmen von Gegenständen aus dem Behälter über einen oberen Abschnitt des Behälters vorgesehen ist.

3. Behälter nach Anspruch 1 oder Anspruch 2, wobei der Behälter eine Rahmenstruktur umfasst, die einen Boden und einen äußeren Umfang festlegt.

4. Behälter nach Anspruch 2, wobei das Sicherungsmittel so angeordnet ist, dass zum Beispiel Rahmenelemente von nebeneinander benachbarten Behältern mittels Festklemmen befestigt werden können.

5. Behälter nach einem der vorhergehenden Ansprüche, wobei das Sicherungsmittel so angeordnet ist, dass gleiche in nebeneinander liegender Beziehung platzierte Behälter so befestigt sind, dass sie gemeinsam angehoben oder bewegt werden können.

6. Behälter nach einem der vorhergehenden Ansprü-

che, wobei:

- i) das Sicherungselement (17) drehbar oder gelenkig angebracht ist, um aus der Verstaueungstellung in die Einsatzstellung gedreht zu werden, und/oder
ii) wobei das Sicherungselement (17) so ausgelegt ist, dass es zu einem Sicherungseingriff mit einer komplementären Anordnung passt, die an dem nebeneinander platzierten Behälter vorgesehen ist.

7. Behälter nach einem der vorhergehenden Ansprüche, wobei:

- i) das Sicherungsmittel im Bereich des Bodens des Behälters vorgesehen ist und/oder
ii) das Sicherungsmittel im Bereich des Oberteils des Behälters vorgesehen ist.

8. Behälter nach einem der vorhergehenden Ansprüche, wobei die unterbauten Sprossenführungen (8, 9) so ausgelegt sind, dass sie Hebesprossen einer Hebevorrichtung aufnehmen.

9. Behälter nach Anspruch 8, wobei ein entsprechendes drehbares Stützelement (10, 11) für eine entsprechende Sprossenführung (8, 9) vorgesehen und benachbart dazu platziert ist.

10. Behälter nach Anspruch 9, wobei die entsprechende Sprossenführung von dem entsprechenden drehbaren Stützelement nach außen gerichtet platziert ist.

11. Behälter nach Anspruch 9 oder Anspruch 10, wobei die Sprossenführung eine Winkelanordnung oder eine Winkelbefestigung für das drehbare Stützelement umfasst.

12. Behälter nach einem der Ansprüche 9 bis 11, wobei die drehbaren Stützelemente so angeordnet sind, dass sie gewährleisten, dass die Sprossenführungen frei über der Bodenfläche platziert sind, um zu ermöglichen, dass der Behälter auf bewegliche Weise auf den drehbaren Elementen abgestützt ist.

13. Behälter nach einem der vorhergehenden Ansprüche, wobei:

- i) die drehbaren Stützelemente (10, 11) Räder oder Laufrollen umfassen und/oder
ii) der Behälter aufrecht stehende Eckpfosten (2, 3, 4, 5) aufweist, die in der Höhe verstellbar sind und Anordnungen umfassen, die es ermöglichen, dass gleiche Behälter übereinander gestapelt werden können, und/oder
iii) der Behälter aufrecht stehende Eckpfosten (2, 3, 4, 5) aufweist, die mit Stapelanordnungen

versehen sind, die es ermöglichen, dass gleiche Behälter übereinander gestapelt werden können.

14. Behälter nach einem der vorhergehenden Ansprüche, wobei:

- i) zwei Paare von gegenüber platzierten Sprossenführungen (8, 9) vorgesehen sind, und zwar jeweils ein Paar auf jeder gegenüberliegenden Seite des Behälters, und/oder
- ii) der Behälter eine kurze Breite und eine relativ große Länge aufweist.

15. Verfahren zum Transportieren von Material, umfassend das Aneinandersichern einer Vielzahl von in nebeneinander liegender Beziehung platzierten Behältern (1) nach einem der vorhergehenden Ansprüche und das gemeinsame Bewegen/Anheben der Behälter zwischen einer Vielzahl von Entlade- oder Beladestellen, anschließendes Beladen der Behälter mit wenigstens etwas Material an den verteilten Entlade-/ Beladestellen, das Außereingriffbringen und Trennen der Behälter, um den weiteren Transport in getrenntem Zustand zu ermöglichen.

Revendications

1. Conteneur (1) pour transporter et/ou stocker des articles, dans lequel:

le conteneur est pourvu de guides de dents surbaissés (8, 9) pour assister le levage du conteneur, et également d'éléments de support rotatifs (10, 11) sur lesquels le conteneur peut être déplacé, et de moyens de fixation pour des conteneurs identiques positionnés dans une relation côte à côte à fixer de façon détachable les uns aux autres, dans lequel les moyens de fixation comprennent un élément de fixation (17) monté sur le conteneur et déployable à partir d'une position repliée jusqu'à une position déployée pour fixer des conteneurs identiques, **caractérisé en ce que** les guides de dents (8, 9) sur des conteneurs fixés de façon adjacente positionnés dans une relation côte à côte sont coalignés les uns avec les autres.

2. Conteneur selon la revendication 1, dans lequel l'accès pour placer des articles dans le conteneur ou pour enlever des articles du conteneur est prévu à travers une partie supérieure du conteneur.
3. Conteneur selon la revendication 1 ou la revendication 2, dans lequel le conteneur comprend une structure de cadre qui définit une base et une périphérie.

4. Conteneur selon la revendication 2, dans lequel les moyens de fixation sont agencés de manière à fixer, par exemple à l'aide d'un serrage, des éléments de cadre de conteneurs adjacents côte à côte.

5. Conteneur selon l'une quelconque des revendications précédentes, dans lequel les moyens de fixation sont agencés de manière à fixer des conteneurs identiques positionnés dans une relation côte à côte de telle sorte qu'ils puissent être soulevés ou déplacés ensemble.

6. Conteneur selon l'une quelconque des revendications précédentes, dans lequel:

i) l'élément de fixation (17) est monté ou articulé de façon pivotante de manière à pivoter depuis la position repliée jusqu'à la position déployée; et/ou

ii) dans lequel l'élément de fixation (17) est configuré de manière à réaliser un engagement de fixation avec une formation complémentaire prévue sur le conteneur positionné côte à côte.

7. Conteneur selon l'une quelconque des revendications précédentes, dans lequel:

i) les moyens de fixation sont prévus à proximité de la base du conteneur, et/ou

ii) les moyens de fixation sont prévus à proximité du sommet du conteneur.

8. Conteneur selon l'une quelconque des revendications précédentes, dans lequel les guides de dents surbaissés (8, 9) sont configurés de manière à recevoir des dents de levage d'un appareil de levage.

9. Conteneur selon la revendication 8, dans lequel un élément de support rotatif respectif (10, 11) est prévu pour un guide de dent respectif (8, 9) et est positionné de façon adjacente à celui-ci.

10. Conteneur selon la revendication 9, dans lequel le guide de dent respectif est positionné vers l'extérieur de l'élément de support rotatif respectif.

11. Conteneur selon la revendication 9 ou la revendication 10, dans lequel le guide de dent comprend une formation de console ou une monture de console pour l'élément de support rotatif.

12. Conteneur selon l'une quelconque des revendications 9 à 11, dans lequel les éléments de support rotatifs sont agencés de manière à assurer que les guides de dents soient positionnés largement au-dessus de la surface du sol, permettant au conteneur d'être supporté de façon mobile sur les éléments rotatifs.

13. Conteneur selon l'une quelconque des revendications précédentes, dans lequel:

- i) les éléments de support rotatifs (10, 11) comprennent des roues ou des roulettes; et/ou 5
- ii) le conteneur présente des montants de coin verticaux (2, 3, 4, 5) qui sont réglables en hauteur et qui comportent des formations qui permettent à des conteneurs identiques d'être empilés les uns au-dessus des autres; et/ou 10
- iii) le conteneur présente des montants de coin verticaux (2, 3, 4, 5) qui sont pourvus de formations d'empilage qui permettent à des conteneurs identiques d'être empilés les uns au-dessus des autres. 15

14. Conteneur selon l'une quelconque des revendications précédentes, dans lequel:

- i) deux paires de guides de dents positionnés de façon opposée (8, 9) sont prévues, une paire sur chaque côté opposé du conteneur; et/ou 20
- ii) le conteneur présente une largeur courte et une longueur relativement longue. 25

15. Procédé de manipulation de matériel, le procédé comprenant la fixation les uns aux autres d'une pluralité de conteneurs (1) selon l'une quelconque des revendications précédentes dans une relation côte à côte, et le déplacement/levage des conteneurs ensemble entre une pluralité de points de saisie ou de chargement; ensuite le chargement des conteneurs avec au moins une partie du matériel aux points de saisie/chargement distribués, le désengagement et la séparation des conteneurs pour permettre la suite du transport de façon séparée. 30
35

40

45

50

55

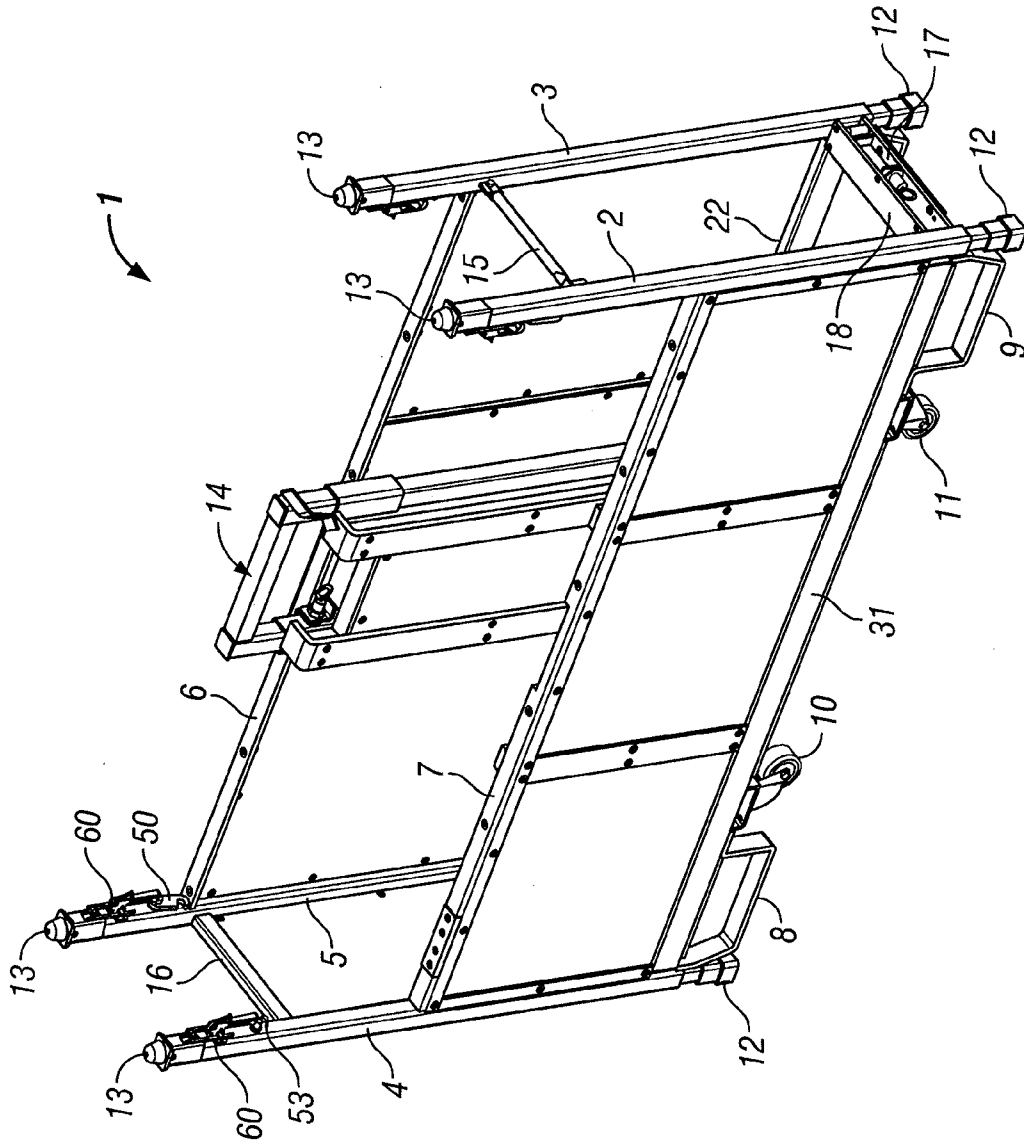

FIG. 1

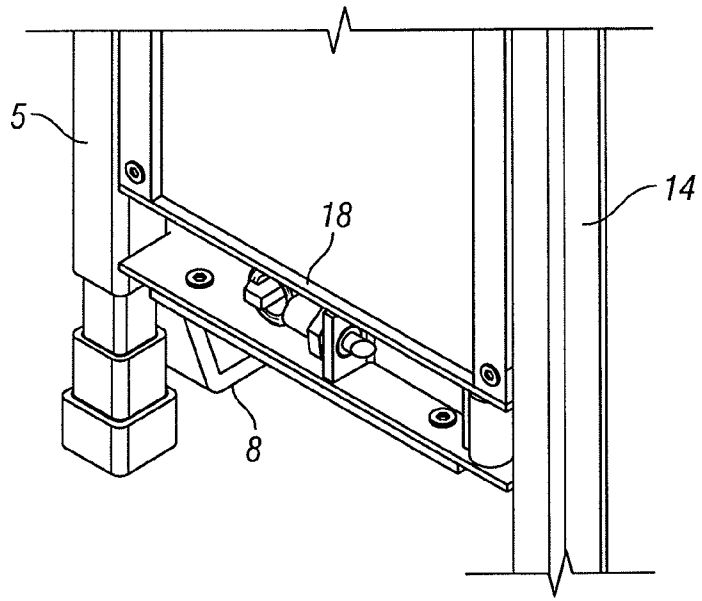

FIG. 2

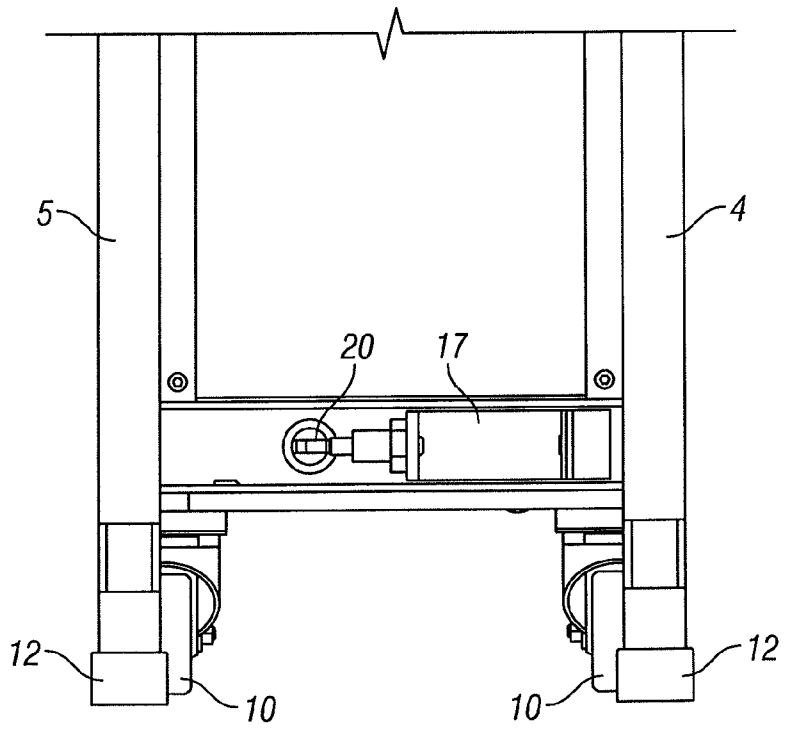

FIG. 3

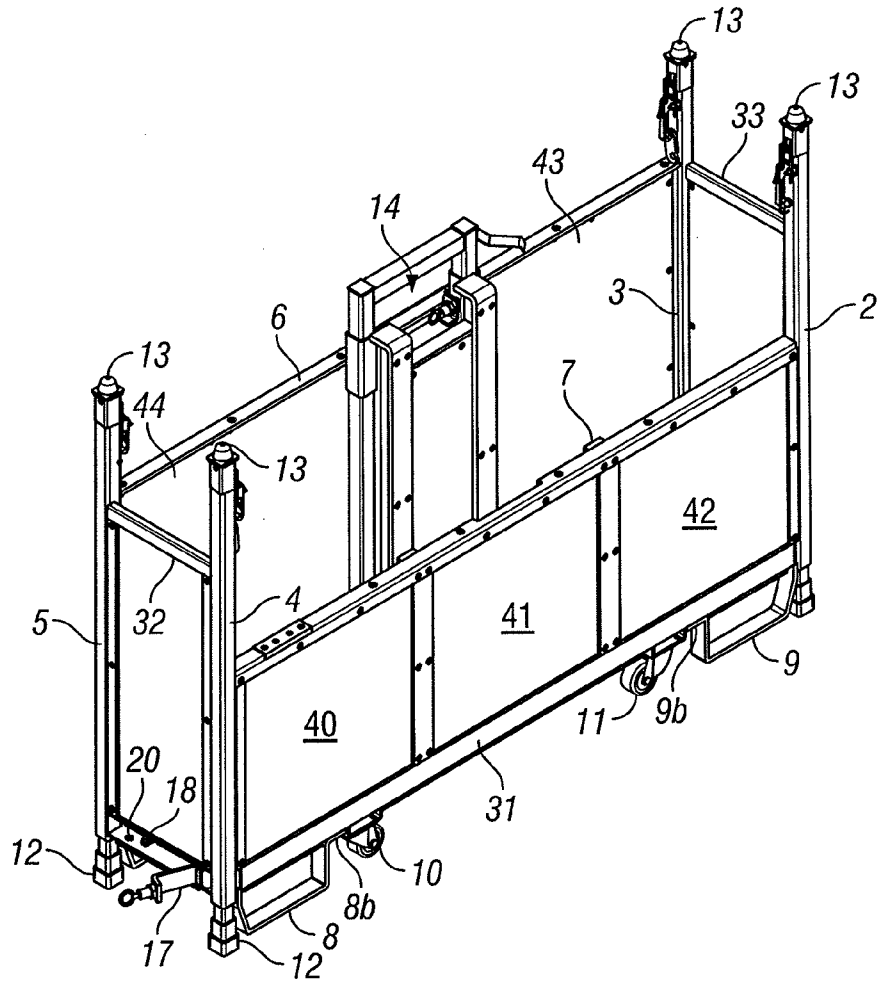

FIG. 4

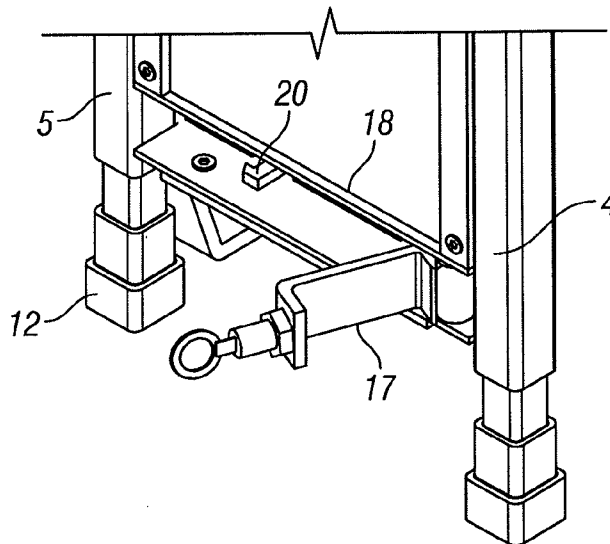

FIG. 5

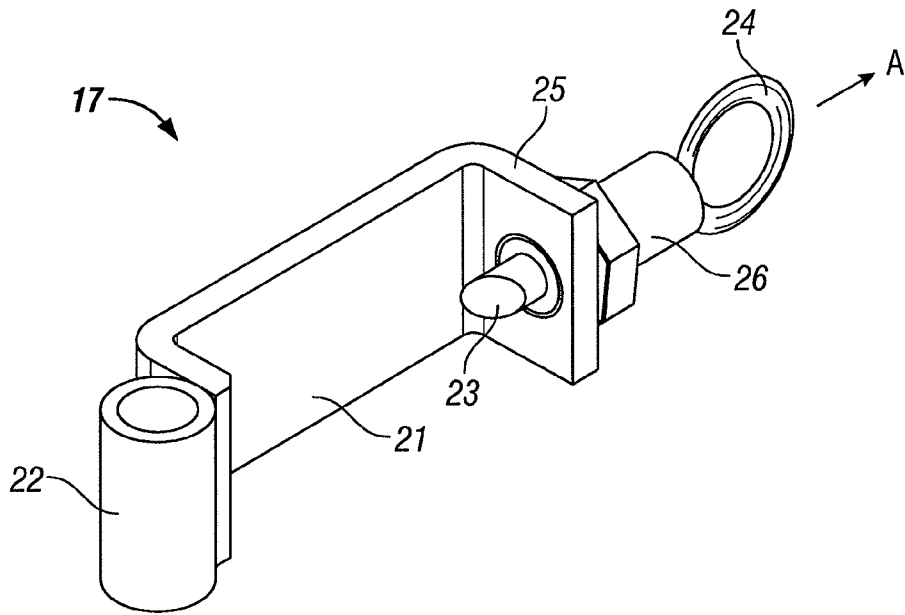

FIG. 6

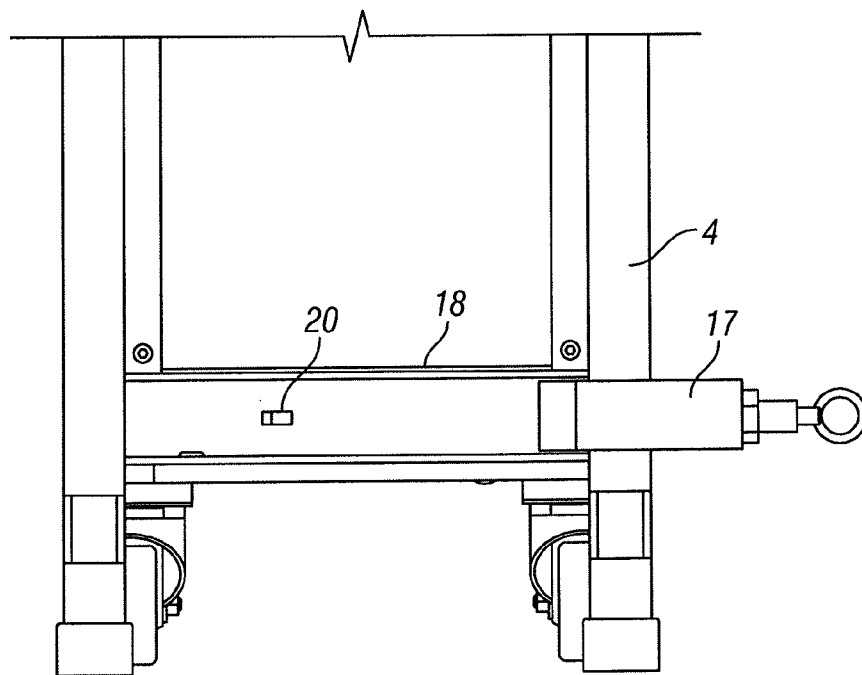

FIG. 7

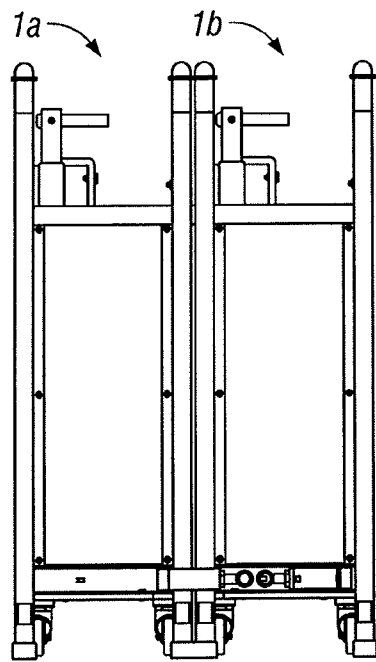

FIG. 8

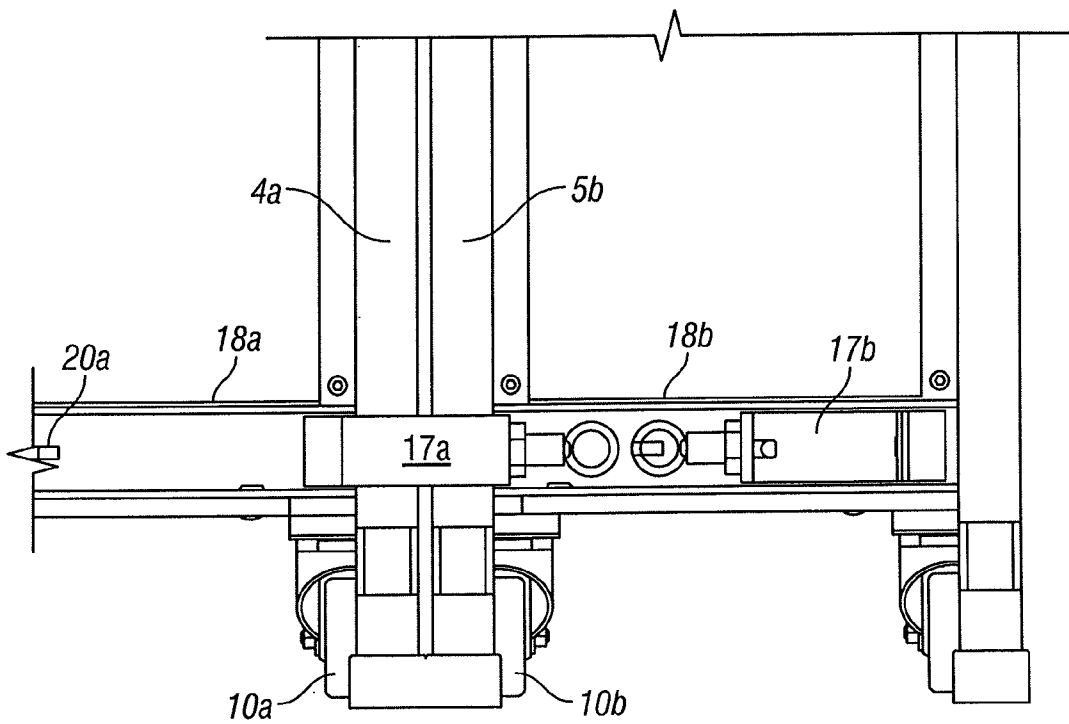

FIG. 9

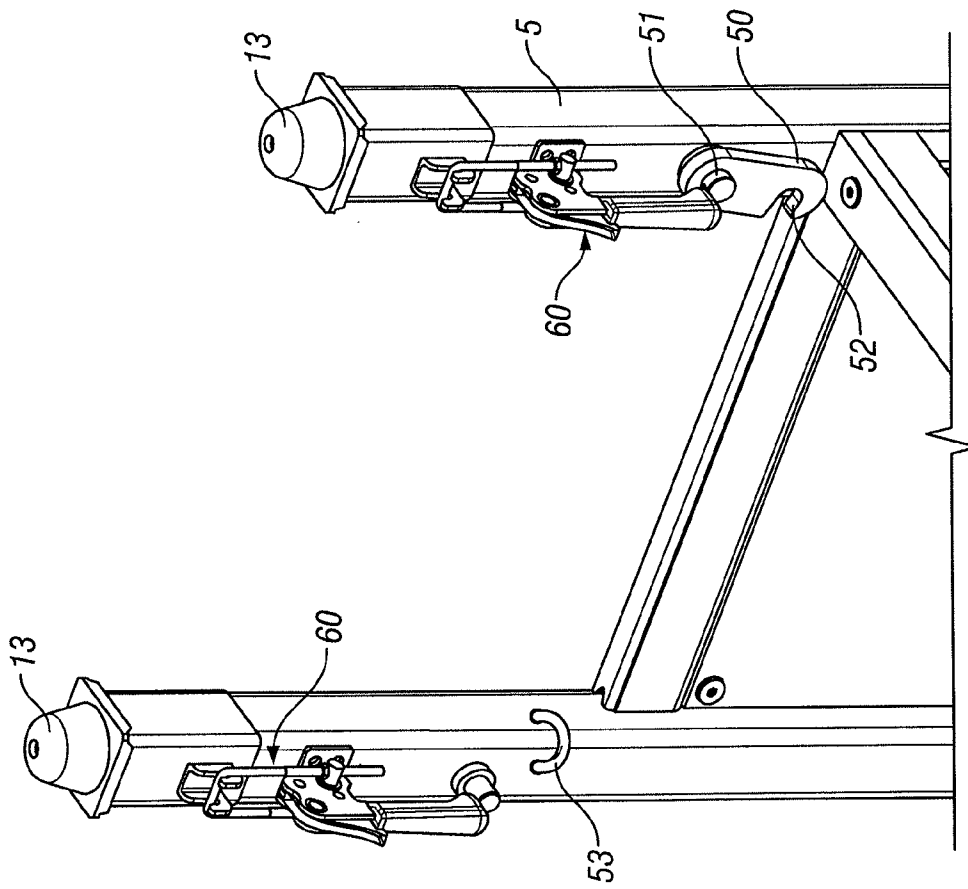

FIG. 10

REFERENCES CITED IN THE DESCRIPTION

This list of references cited by the applicant is for the reader's convenience only. It does not form part of the European patent document. Even though great care has been taken in compiling the references, errors or omissions cannot be excluded and the EPO disclaims all liability in this regard.

Patent documents cited in the description

- EP 1737764 A [0002] [0025] [0030]
- GB 2480673 A [0002]



KONTÉNER

SZABADALMI IGÉNYPONTOK

1. Konténer (1) tárgyak tárolására és/vagy szállítására, ahol:
a konténer el van látva alsó, emelővilla befogadó vezetékkel (8, 9) a konténer emelésének segítésére, valamint forgó támasztó elemekkel (10, 11), amiken a konténer mozgatható, és rögzítő elemmel egymás mellé helyezett konténerek oldható összekapcsolására, ahol a rögzítő elem tartalmaz egy rögzítő kapcsolót (17), ami a konténerre van felszerelve és nyugalmi helyzetből működő helyzetbe fordítható a konténerek rögzítésére, **azzal jellemezve, hogy az egymás mellé rögzített konténereken lévő befogadó vezetékek (8, 9) egymással fedésben vannak.**
2. Az 1. igénypont szerinti konténer, ahol hozzáférés van biztosítva tárgyak behelyezéséhez és kivételéhez a konténer felső részén.
3. Az 1. vagy 2. igénypont szerinti konténer, ahol a konténer tartalmaz egy keretszerkezetet, aminek van egy alja és egy kerete.
4. A 2. igénypont szerinti konténer, ahol a rögzítő elem úgy van elrendezve, hogy összekapcsolja – például kapcsolókkal – az egymás melletti konténerek keret elemét.
5. Az előző igénypontok bármelyike szerinti konténer, ahol a rögzítő elem úgy van elrendezve, hogy összekapcsolja az egymás melletti konténereket együltőtörtéző emeléshez vagy mozgatáshoz.
6. Az előző igénypontok bármelyike szerinti konténer, ahol:
 - i) a rögzítő kapocs (17) billenthetően vagy csuklósan mozgatható nyugalmi helyzetből működő helyzetbe; és/vagy ahol
 - ii) a rögzítő kapocs (17) úgy van kialakítva, hogy rögzítő kapcsolattal illeszkedjék egy szomszédos konténer komplementer eleméhez.
7. Az előző igénypontok bármelyike szerinti konténer, ahol:
 - i) a rögzítő elem a konténer aljának közelében van elrendezve; és/vagy
 - ii) a rögzítő elem a konténer felső részének közelében van elrendezve.
8. Az előző igénypontok bármelyike szerinti konténer, ahol a befogadó vezetékek (8, 9) úgy vannak kialakítva, hogy befogadják egy emelő berendezés emelővilláit.
9. A 8. igénypont szerinti konténer, ahol a befogadó vezetékekhez (8, 9) forgó támasztó elemek (10, 11) vannak hozzárendelve és mellettük elrendezve.
10. A 9. igénypont szerinti konténer, ahol az adott befogadó vezeték a hozzájuk tartozó forgó támasztó elemekhez képest kifelé vannak elhelyezve.
11. A 9. vagy 10. igénypont szerinti konténer, ahol a befogadó vezeték tartalmaz egy bilincs alakzatot vagy egy bilincset a forgó támasztó elem megtartására.
12. A 9 - 11. igénypontok bármelyike szerinti konténer, ahol a forgó támasztó elemek úgy vannak elrendezve, hogy a befogadó vezetékek elég magasán legyenek a padlózathoz képest, hogy lehetőség legyen a konténer mozgatására a forgó támasztó elemek segítségével.
13. Az előző igénypontok bármelyike szerinti konténer, ahol:
 - i) a forgó támasztó elemek (10, 11) kerekeket vagy görgőket tartalmaznak; és/vagy

- ii) a konténer tartalmaz felfelé nyúló sarokoszlopokat (2, 3, 4, 5), amik állítható magasságúak és el vannak látva alakos elemekkel, amik lehetővé teszik egy konténer elhelyezését egy másik tetején, és/vagy
- iii) a konténer tartalmaz felfelé nyúló sarokoszlopokat (2, 3, 4, 5), amik el vannak látva alakos elemekkel, amik lehetővé teszik egy konténer elhelyezését egy másik tetején.

14. Az előző igénypontok bármelyike szerinti konténer, ahol:

- i) két pár szemben fekvő befogadó vezeték (8, 9) van elrendezve a konténer szemben fekvő oldalain; és/vagy
- ii) a konténer keskeny és viszonylag hosszú.

15. Eljárás anyag szállításra, ahol az eljárás során összekapcsolunk több, az előző igénypontok bármelyike szerinti konténert (1) egymás mellé, és elmozdítjuk/felemeljük a konténereket együttesen több felvevő vagy rakodó hely között, majd a konténerek rakodása után legalább valamilyen anyaggal az elosztott rakodó/kirakodó helyeken, szétkapcsoljuk és elválasztjuk a konténereket további szétválasztva végzett szállításhoz.