

J. LEONHARDT.
MACHINE FOR PRESSING BRICKS, TILES, &c.

No. 523,797.

Patented July 31, 1894.

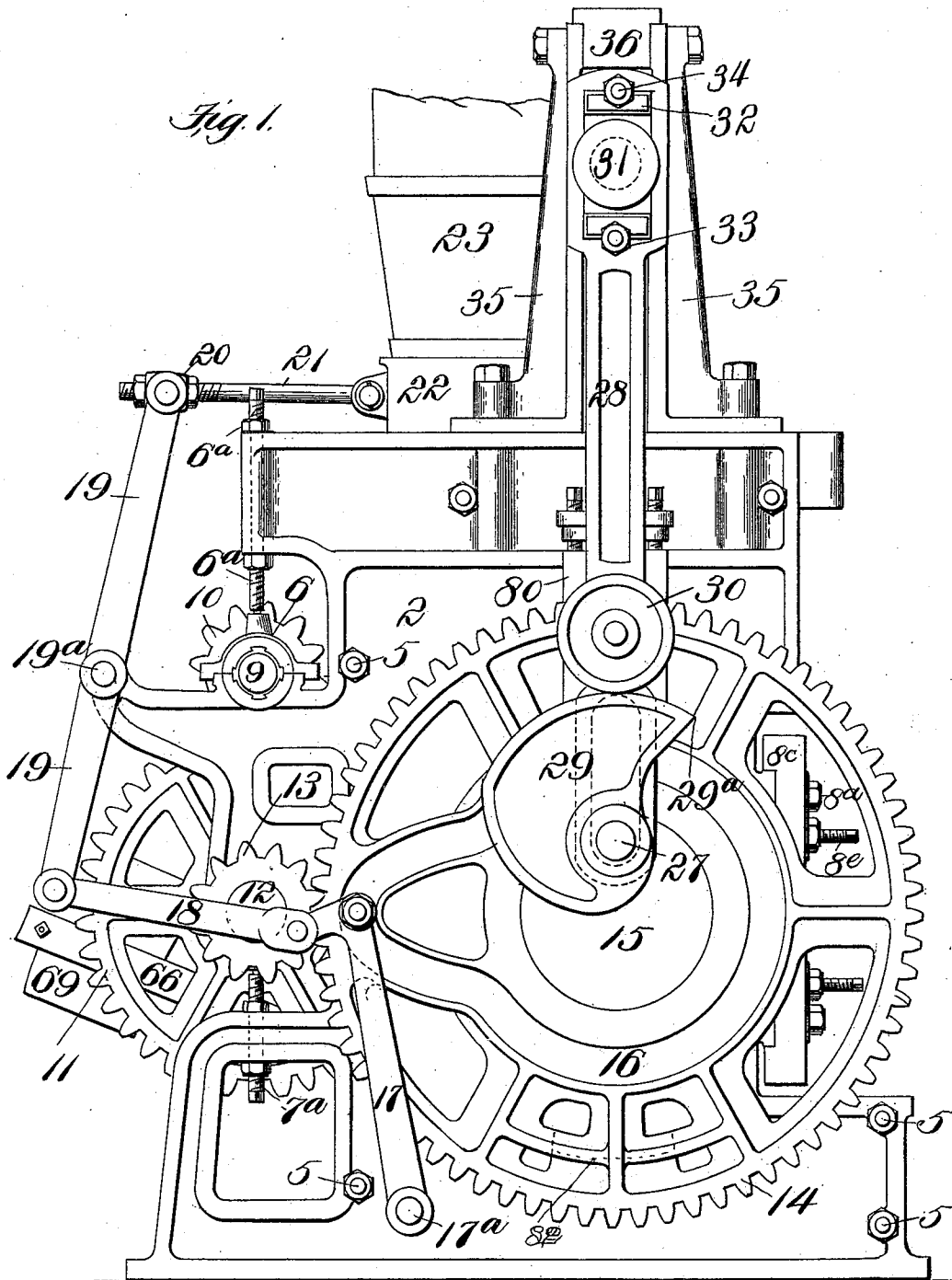

Witnesses
J. P. Cornwall
Hugh Wagner

Inventor
Jacob Leonhardt
 By *Paul Bakewell*
his atty.

J. LEONHARDT.

MACHINE FOR PRESSING BRICKS, TILES, &c.

No. 523,797.

Patented July 31, 1894.

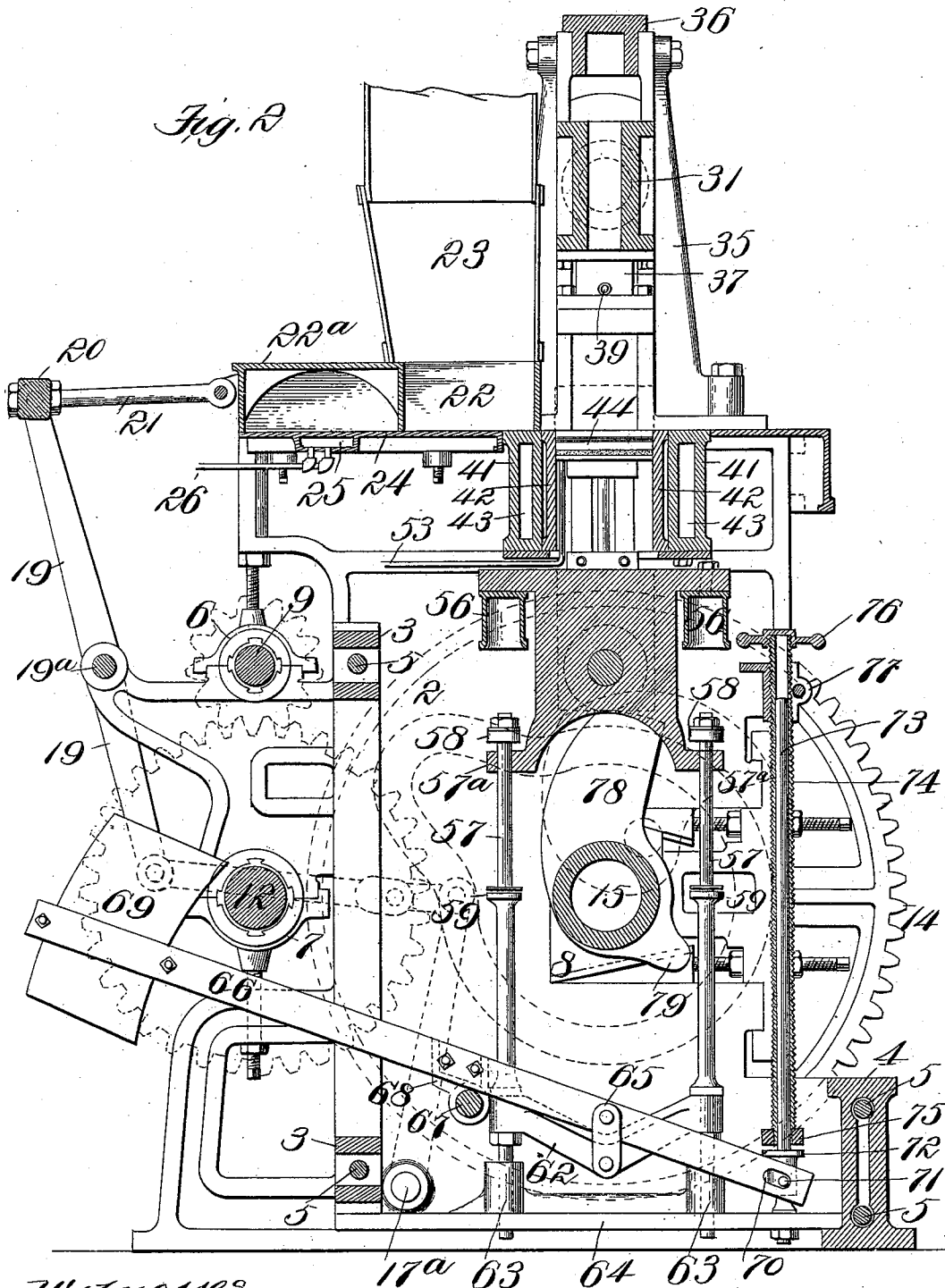

Witnesses
J. St. Cornwall
Hugh H. Wagner

Inventor
Jacob Leonhardt
 By *Paul Bakerwell*
Att'y

J. LEONHARDT.

MACHINE FOR PRESSING BRICKS, TILES, &c.

No. 523,797.

Patented July 31, 1894.

Fig. 3.

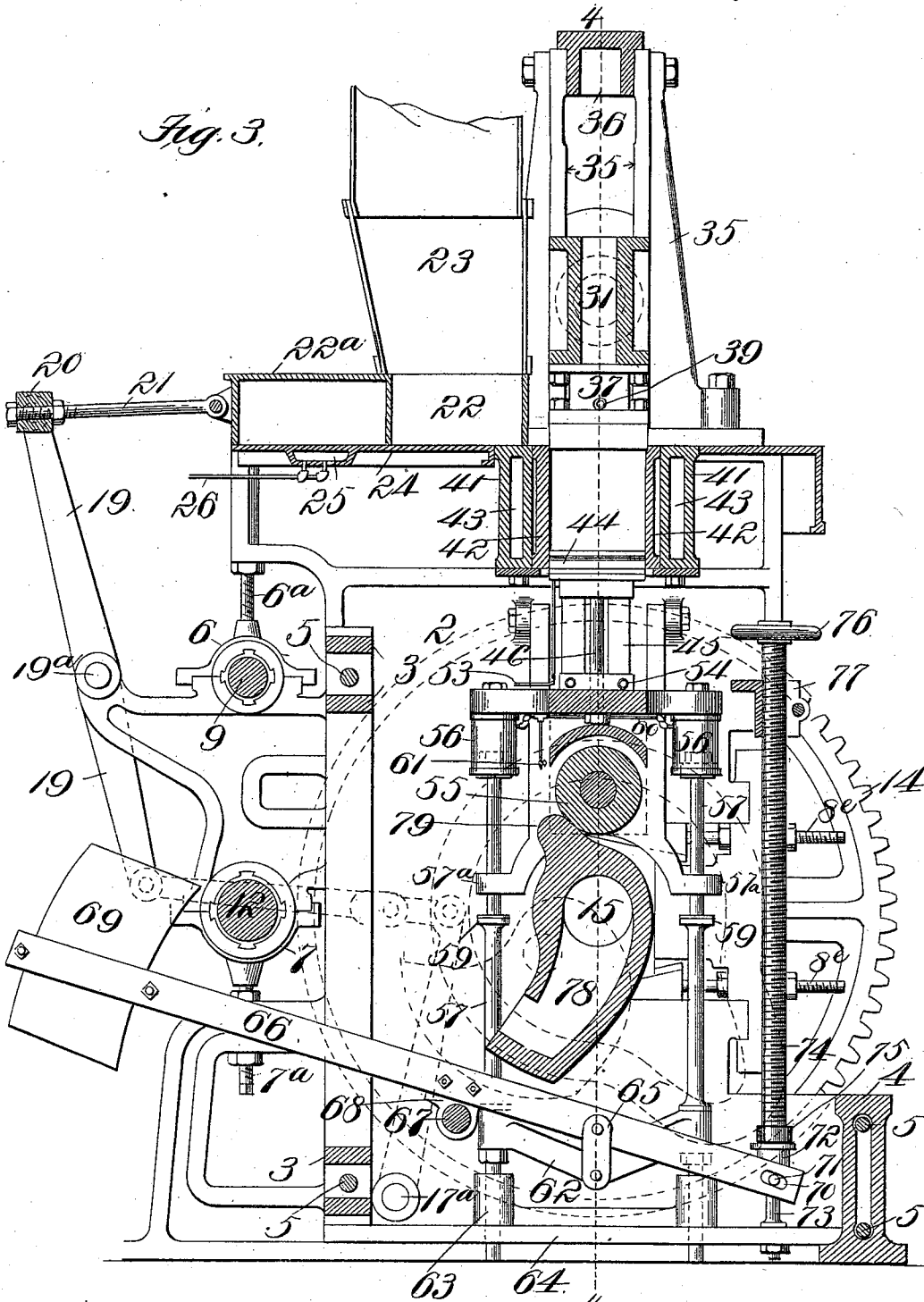

Witnesses
F. P. Cornwall
Hugh Wagner

Inventor,
Jacob Leonhardt.
 By *Paul Bakewell*
 his atty.

J. LEONHARDT.

MACHINE FOR PRESSING BRICKS, TILES, &c.

No. 523,797.

Patented July 31, 1894.

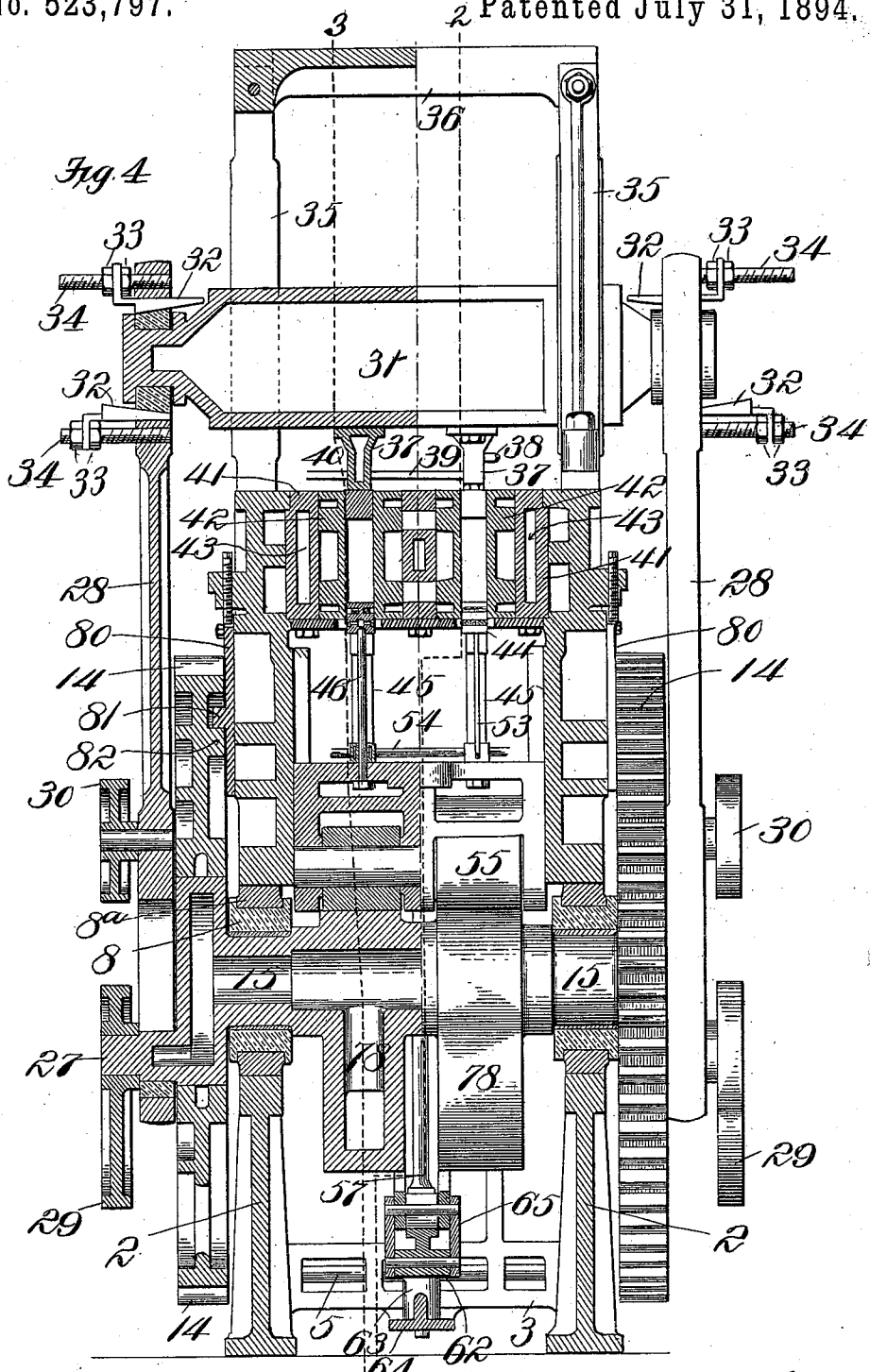

Witnesses:
S. P. Cornwall
Hugh V. Wagner

Inventor
Jacob Leonardt.
 By *Paul Baker*
his atty.

J. LEONHARDT.

MACHINE FOR PRESSING BRICKS, TILES, &c.

No. 523,797.

Patented July 31, 1894.

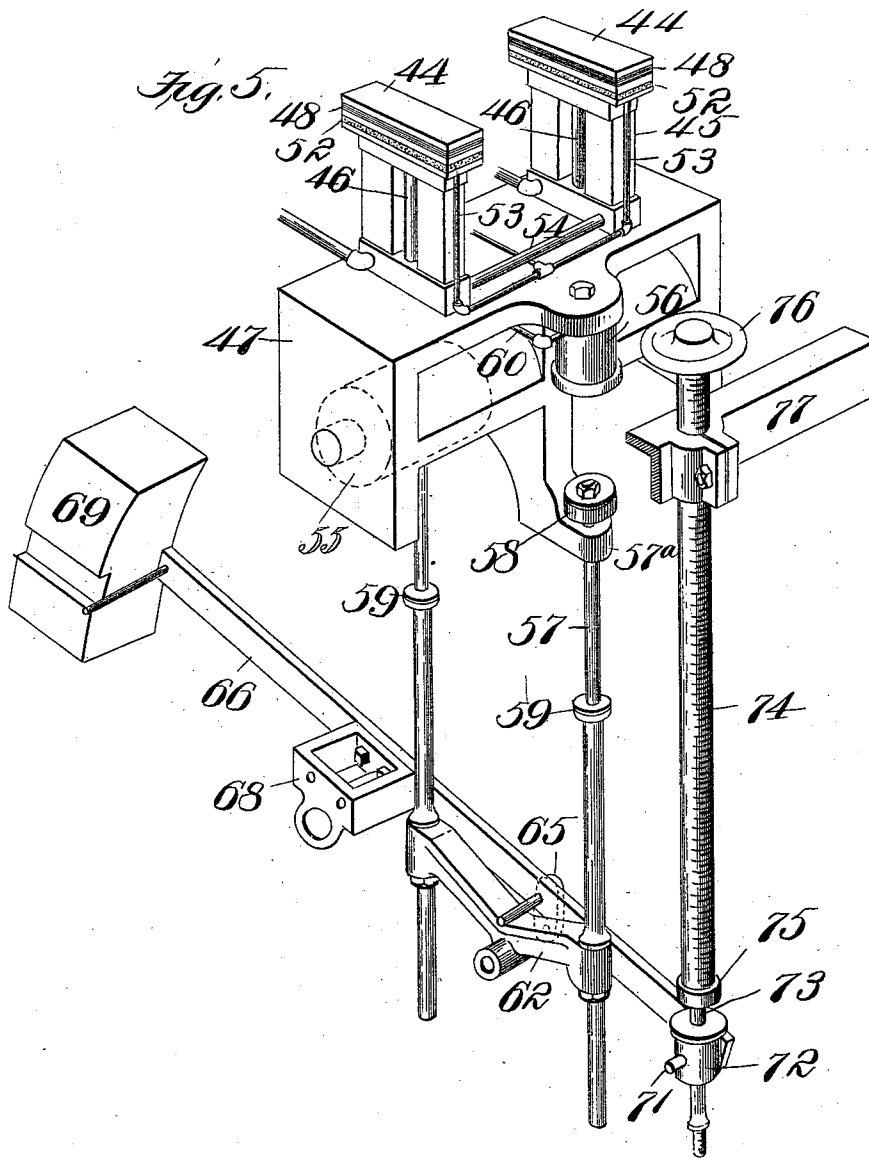

Witnesses
J. P. Cornwall
Hugh K. Wagner

Inventor,
Jacob Leonardt
 By *Paul Bakerell*
his atty.

J. LEONHARDT.

MACHINE FOR PRESSING BRICKS, TILES, &c.

No. 523,797.

Patented July 31, 1894.

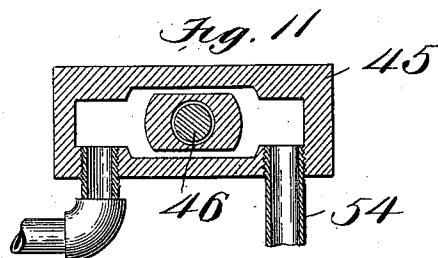
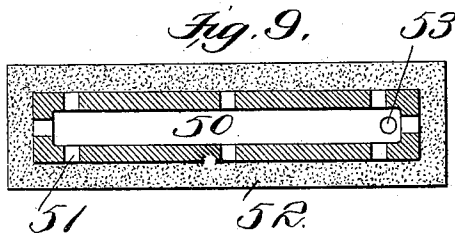
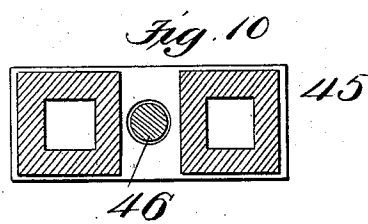
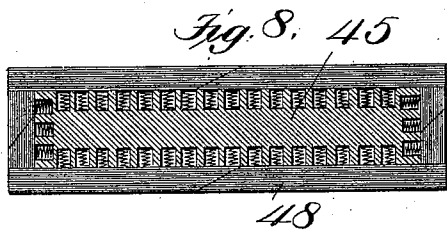
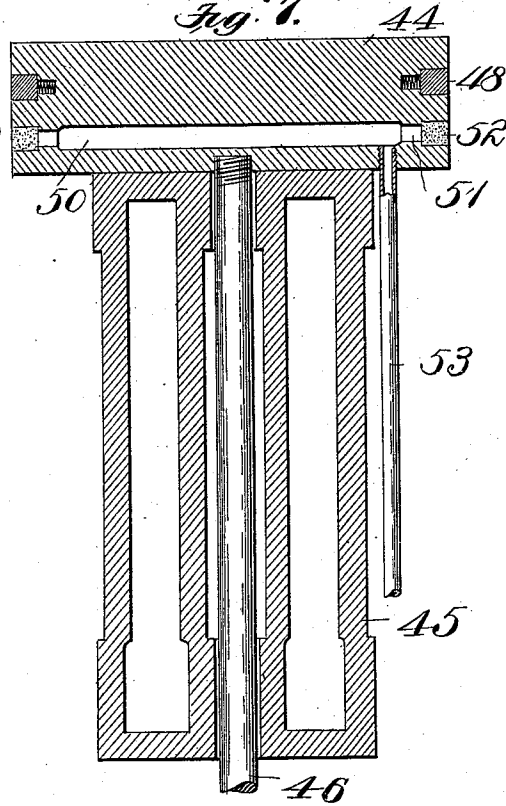
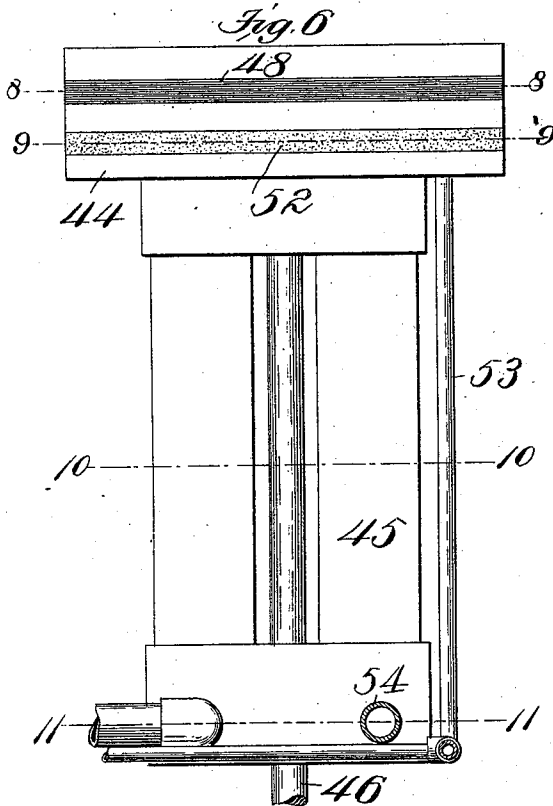

Witnesses
J. P. Cornwall
Hugh Wagner

Inventor
Jacob Leonhardt,
 By *Paul Patwell*
 his atty.

J. LEONHARDT.
MACHINE FOR PRESSING BRICKS, TILES, &c.

No. 523,797.

Patented July 31, 1894.

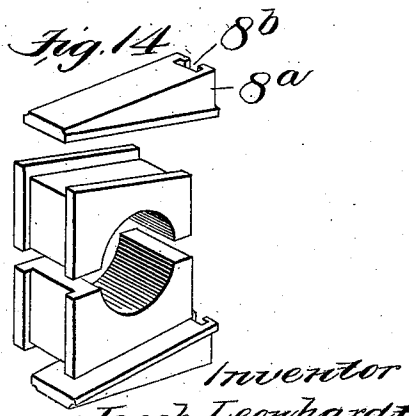
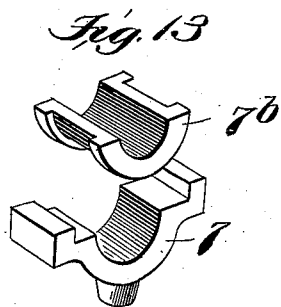
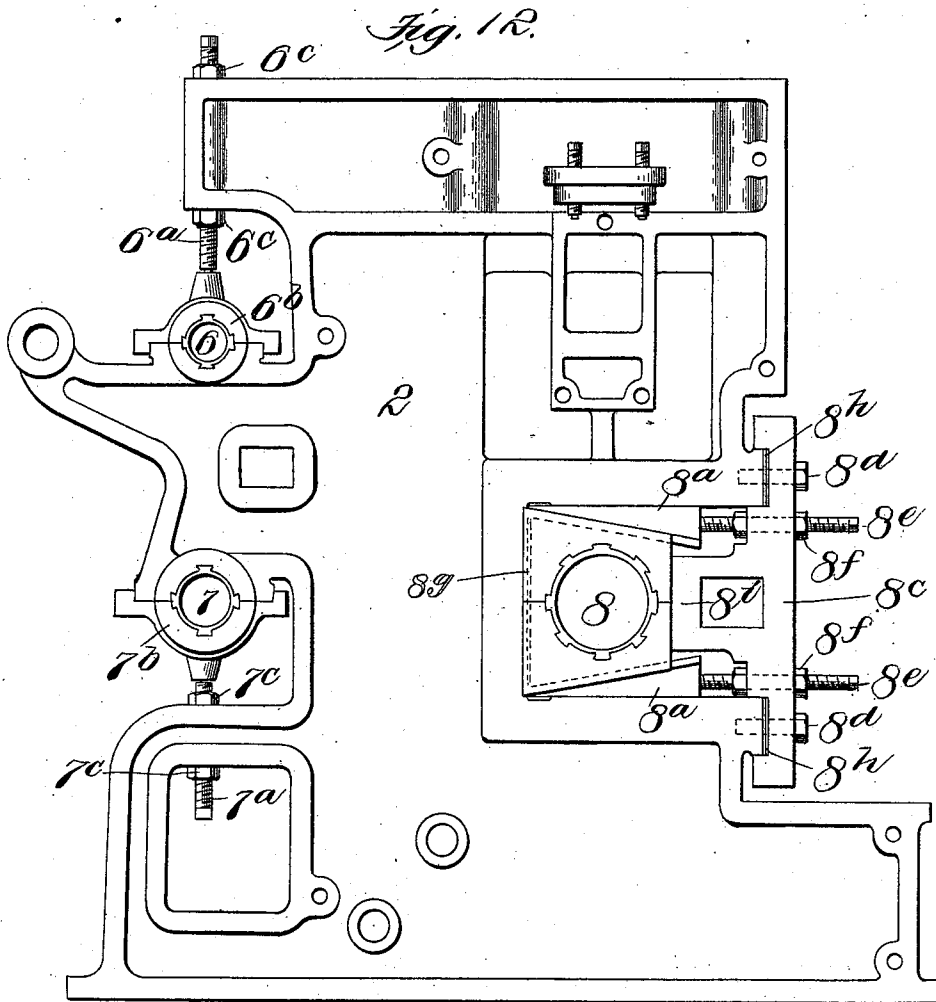

Witnesses
J. St. Cornwall
Hugh K. Wagner

Inventor
Jacob Leonhardt
 By *Paul Bakewell*
his atty.

UNITED STATES PATENT OFFICE.

JACOB LEONHARDT, OF ST. LOUIS, MISSOURI, ASSIGNOR TO THE COLUMBIA MANUFACTURING COMPANY, OF SAME PLACE.

MACHINE FOR PRESSING BRICKS, TILES, &c.

SPECIFICATION forming part of Letters Patent No. 523,797, dated July 31, 1894.

Application filed August 14, 1893. Serial No. 483,091. (No model.)

To all whom it may concern:

Be it known that I, JACOB LEONHARDT, a citizen of the United States, residing in the city of St. Louis, State of Missouri, have invented a certain new and useful Improvement in Machines for Pressing Bricks, Tiles, &c., of which the following is a full, clear, and exact description, reference being had to the accompanying drawings, forming a part of this specification, wherein—

Figure 1 represents a side elevation. Fig. 2 is a vertical longitudinal sectional view taken on line 2—2, Fig. 4, indicating the position of the parts just before the brick is pushed from the lower mold. Fig. 3 is a similar view taken on line 3—3, Fig. 4, showing the position of the parts just before the brick receives its final pressure. Fig. 4 is a transverse sectional view taken on line 4—4, Fig. 3, showing several of the parts in elevation. Fig. 5 is a detail perspective view of the drop box, lower plungers, and the means for regulating the fall of the drop box. Fig. 6 is a side elevation of one of the lower plungers. Fig. 7 is a longitudinal section therethrough. Fig. 8 is a horizontal section, taken through the expanding packing strips on line 8—8 of Fig. 6. Fig. 9 is a horizontal section through the oiled packing, taken on line 9—9 of Fig. 6. Fig. 10 is a horizontal section, taken through the hollow vertical members of the plungers, taken on line 10—10 of Fig. 6. Fig. 11 is a similar view, taken through the bottom or bed of the plunger on line 11—11, Fig. 6. Fig. 12 is a detail side elevation of one of the frame pieces, illustrating the adjustable bearing blocks and their means of adjustment. Fig. 13 is a detail view of some of the parts which go to make up the adjustable bearing for the power-transmitting shaft; and Fig. 14 is a similar view, in detail, of the parts going to make up the main shaft bearing.

My invention relates to a new and useful improvement in machines for making bricks, tiles, and other articles formed by pressing powdery clay or other suitable material into shape, and is designed especially for making what is known as ornamental or fancy brick.

The invention consists more particularly in details of improvement over United States Patent No. 298,646, of May 13, 1884, granted

to Thomas Whittaker, which may be summed up under the following:

The essential feature of this present invention is the means whereby the upper and lower plungers move in the same direction but at different speeds, which makes the machine more effective and enables the same to put a greater amount of pressure on the brick than if the two plungers came together by moving in opposite directions. Incidentally to this are the details of construction whereby this feature is effected, which details reside particularly in the distribution of the strain over the frame of the machine, and in the means for absorbing this great pressure.

Another feature of this invention resides in the construction of the lower plungers, which not only obviates the necessity of frequent changes by reason of their wear, but which plungers are provided with wear strips or expanding packing strips which tend by their contact with the sides of the mold cavity lining to hold a plunger proper in the center of the mold cavity.

Other details of invention reside also in the peculiar construction of this lower plunger.

Other features of invention reside in means for absorbing the jar caused by the falling of the drop box just prior to the filling of the mold cavity with the loose material, which consists of open-ended cylinders which are placed in the path of plungers, said plungers being made adjustable in order to regulate the amount of material which the mold cavity will receive. Incidentally to this, is the means for regulating the pressure of air in the two cylinders in order to equalize it, and the means for adjusting the two plungers.

Another feature of invention resides in adjustably mounting shoes or wear plates on the sides of the machine, which are very close to the main gear wheels, which shoes or wear plates contact with said wheels when the same are receiving their greatest pressure, by which means the said wheels are prevented from springing inwardly at their upper ends, which is caused by the sagging of the main shaft in the middle at which point the pressure is directed downward, and in that way becoming untrue.

Other features of invention reside in the

construction, arrangement and combination of the several parts, all as will hereinafter be described and afterward pointed out in the claims.

5 In the drawings, 2 indicates the side framing of the machine, which pieces are cross-braced as at 3 and 4, and held together by through-bolts 5. In this frame are received the adjustable bearings 6, 7, and 8, in the first
10 of which is mounted a shaft 9 which receives power from any suitable source and transmits it through a pinion 10 to a spur wheel 11, mounted on a shaft 12, journaled in the bearing 7. On the ends of this shaft 12, are
15 pinions 13, which mesh with the driving wheels 14, mounted on the main or cam shaft 15, journaled in the bearings 8. The bearings 6 and 7 are made adjustable through the medium of bolts or threaded rods 6^a and 7^a,
20 respectively, which pass through the side framing and find bearings in bosses on the detachable half-bearings of the boxes. These half-bearings confine split packing rings 6^b and 7^b, which may be made adjustable to and
25 from the frame by the introduction of liners, as is common, and the impingement of the bolts 6^a and 7^a, which latter are held in their positions by jam nuts 6^c and 7^c received thereon and bearing on each side of the frame.

30 The bearing 8 for the main or cam shaft is composed of a split box having a way formed at its large or rear end, the flanges of which project over the sides of the frame. The top and bottom faces of this split box are formed
35 with an inclined way into which are received wedges 8^a, which wedges have bolt seats formed in their enlarged ends. The framing 2 is formed with an opening or recess for these wedges and the split-box, over which
40 recess extends a bridge piece 8^c, removably secured to the frame by bolts 8^d. Passing through this bridge piece and seated in the bolt seats 8^b in the wedges are adjusting bolts 8^e, upon which are received jam nuts 8^f, bearing
45 upon each side of the bridge piece, which jam nuts hold the bolts and wedges in a fixed position. To take up the wear or play in the boxes, these wedges may be forced inward, thereby bringing the two halves of the
50 split box into a closer relation, and to adjust or true up the main or cam shaft, the wedges may be withdrawn or forced in for the purposes of vertical adjustment and for purposes of horizontal adjustment liners may be introduced or taken away from behind the split
55 boxes as indicated at 8^g, or they may be introduced or taken away from the face of the frame 2, indicated at 8^h and the bolts 8^d loosened or tightened, accordingly, which will
60 cause the projection 8ⁱ to impinge against the outer edges of the split journal bearing, thereby holding it tightly in place, in its adjusted position.

65 The driving wheel 14 is formed on its outer face with a cam groove 16, in which runs a cam roller mounted on a lever-arm 17, journaled to the frame at 17^a. Pivottally con-

nected to a projection on the upper end of this arm 17, is a link 18, whose other end is pivoted to the lower member of a rocking
70 arm 19, pivoted to the frame 2 at 19^a. The upper member of this rocking arm 19 supports in an eye at its end a cross-piece 20, through which passes, at about its center an adjustable rod 21, which has its other end
75 pivottally connected on the feed box 22. This feed box, as shown, has its forward end, which normally is in position immediately beneath the feed chute 23, open at its top and bottom, thus permitting the material to fill the
80 same when in a position of rest (the material resting on a table plate 24), and when the feed box is forced forward, through the medium of the train of levers just described, which are actuated by the fluctuation of the cam
85 groove 16, its table portion 22^a will come beneath feed chute 23 and hold the material back while the open ended forward portion passes over the mold cavity and discharges its contents therein. The forward position of
90 the feed box is illustrated in Fig. 1 and the retracted position in Figs. 2 and 3.

The table plate 24, which supports the feed box 22, is preferably formed with a steam chamber 25 on its under side, into which
95 steam pipes 26, connected to any suitable source and discharge, lead. By this means the table plate 24 is heated and the material is prevented from adhering thereto.

The main or cam shaft 15 is preferably
100 formed of a single casting having its center cored out, as shown to the left in Fig. 4. The ends of this shaft are in the form of disks upon which the wheels 14 are shrunk, keyed, or otherwise mounted, while the central portion
105 of the casting is formed with two cams, which operate the drop box and which will hereinafter be referred to. On the outer faces of the disk ends of this casting are formed
110 crank pins 27, which are adapted to play in slots and operate pitman 28. Mounted upon these crank pins are cams 29, the function of which is to engage with and operate rollers
115 30 mounted on the pitman 28, through the medium of which the cross-head 31, which is mounted in the upper ends of the pitman, and which carries the upper plungers or pistons, is raised away from the pressed brick, and elevated so that its plungers will not obstruct the advance of the feed box 22 when
120 the same is moved forward to force the finished brick from off the lower plungers and to fill the mold cavities with loose material. The position the crank pin 27, its cam 29, and the roller 30, assume when it is so elevating
125 the cross-head 31, is illustrated in Figs. 1, and 2. The upper ends of the pitman 28 are provided with adjustable bearing boxes for the cross-head 31, which bearing boxes comprise the two-part bearing as is common, on the upper
130 and lower sides of which are introduced wedges 32 made adjustable by jam nuts 33, threaded on the rods 34. The cross-head 31 is guided in its vertical movement by stand-

ards 35, mounted upon the upper edges of the frame pieces 2, and whose upper ends are spaced by a bridge-piece 36 interposed therebetween and extending across from one pair to the other.

37 indicates the upper plungers or pistons which are bolted or otherwise secured to the cross-head 31 in alignment with the mold cavities and which plungers are made hollow to form steam chambers for the circulation of steam therethrough through the medium of the inlet pipe 38, connecting pipe 39, and exit pipe 40, which are so arranged as to carry off the water of condensation and which inlet pipe 38 and exit pipe 40 are connected to any suitable source of supply and discharge, respectively.

41 indicates the mold box, having adjustable liners 42 therein, which form the mold cavities, which mold box has steam chambers 43 arranged therearound to heat the same.

The lower plungers, as illustrated in Figs. 6 to 11, are formed of two pieces 44 and 45, the former of which is tapped to receive a rod 46, which passes through openings in the section 45 and tightly binds the same through the drop box 47 through which the rod 46 passes. The upper section 44 is grooved out along its sides and ends, near its upper edge,

for the reception of angularly-shaped packing strips 48, which fit snugly therein. Behind these packing strips, are arranged a battery of springs, which exert their pressure to always force the packing strips out against the mold cavity lining, and in that way make a constantly tight joint and one which will yield and absorb the vibration of the plunger without communicating it to the mold box.

This packing extends entirely around the plunger, and in order to permit the several strips to spread longitudinally to form a tight joint in the corners of the mold cavity, I preferably split the several strips diagonally, to form a double wedge, as is common in such devices.

The objects of these packing strips are (first) to absorb the vibration of the plunger and not communicate it to the mold-box; (second) to form a tight joint between the plunger head and mold box, which tight joint

prevents particles of material in the mold-box falling through beyond the plunger head upon the moving surfaces below, such as cams 78 and drop box rollers 55; (third) to prevent the oiling packing from becoming hard by being clogged with particles of grit; and (finally) to hold the particles in a stationary position relative to the plunger, so that they will form a scale around the upper part of the plunger head, and thus fill the space

caused by wear between these parts, and, by so filling this space, enable the formation of a more perfect brick. Of course, it will be understood in this connection that the formation of a scale or the filling of the material around the plunger will at no time be very wide, for in all cases where the lining of the cavity is worn to any great extent, it has to

be replaced. There is, however, this advantage in this construction, and that is, the particles of the material being stationary, relative to the plunger, will form a scale therearound which will become hard and smooth by constant friction, and thus tend to preserve both the plunger and mold-box lining, where in the case of gritty material falling through the worn spaces, each particle having its sharp cutting edges, and there being so many and different particles interposed between these moving parts (the plunger and the mold-box lining) there is a greater tendency to wear.

The section 44 is chambered or cored out, as at 50, near its lower edge, which chamber communicates by ducts or openings 51 to a channel formed entirely around the same into which channel or groove is received packing 52. Leading up into this chamber 50 is a pipe 53, which is received on the under side of the portion 44 and extends down closely along the side of the portion 45 to within a short distance of the top of the drop box 47, where it extends across and is connected to another similar pipe in the other plunger or plungers. There is a pipe connected to this cross-pipe which leads from any suitable source of oil supply, preferably located above the plungers so as to feed the same by gravity. The base and the two vertical portions of the section 45 are hollowed or cored out, forming a steam chamber, as shown in Figs. 7, 10, and 11, which steam chamber is connected to the other plunger or plungers by a cross-pipe 54, and are also provided with suitable inlet and outlet pipes for the circulation of steam. The drop box 47, upon which these plungers are secured through the medium of the bolts 46, is mounted in vertical guide-ways on the inside of the frame-pieces 2. In the lower portions of this drop box are mounted rollers 55, which run on the cams on the main shaft. Extending out from the upper side faces of the drop box are ears or projections upon the lower side of which are mounted cylinders 56, open at their bottom, as shown in Fig. 2. The central partition wall of this drop box is also extended laterally at its bottom to form bearings to guide the plunger stems 57 of the plungers 58, which plungers are in line with the open-ended cylinders just referred to. These plunger stems are provided with cushioned shoulders 59 at about a position to receive the bearings 57^a, to protect the cylinders from the confining nuts of the plungers, should said plungers move too easily within the cylinders by reason of the quick escape of the air therefrom.

In order to equalize the escape of air from the cylinders above the plungers and thereby prevent sticking of the drop box which might otherwise occur, I connect the tops of the chamber of these cylinders by pipe 60, and from said pipe the escape of the air is regulated by a cock 61, as shown in Fig. 3.

The lower ends of the plunger rods 57 are

connected by a cross-beam 62, and they are guided in their vertical movement by the bosses 63, formed on a longitudinally-disposed piece 64, mounted in the bottom of the frame. On the center of this cross-piece 62 is a bearing for the passage of a pin upon which two links 65 are pivotally mounted. The upper ends of these links are pivotally connected to a two-part weight-arm 66, which is pivoted on the shaft 67 through the medium of its bearing 68. Between the arms just referred to, at their rear ends, is secured a weight 69, which has a tendency to always force the plungers 58 upwardly through the medium of the connection by link 65 to the beam 62, being on the other side of the fulcrum-shaft 67. The forward ends of this two-part weight-arm are slotted, as at 70, to receive the lateral projections 71 of a collar 72, which collar is slidingly mounted upon a vertical rod 73 rigidly fixed to the piece 64. Surrounding this rod, is a threaded sleeve 74, having an abutting collar 75 on its lower end with which the sliding collar 72 normally contacts, by reason of the weight 69 tending to force the same and the plungers 58 upwardly. This screw-threaded sleeve is mounted in a cross-piece or bridge frame at the forward end of the machine, and is provided on its upward end with a hand-wheel 76 by which the same may be turned, and by its threaded connection with the cross bridge 77 will raise or lower the stop block 75, and in that way adjust the limit of the fall of the drop box and regulate the amount of the loose material which will be received by the mold cavities. The feed box in the instance of there being too great an amount will draw off and remove the surplusage in its retraction.

78 indicates cams formed in the middle portion of the cored shaft 15, said cams being formed with a tail end 79, over which the roller 55 passes to make the first pressure, said roller after passing the tail-piece gradually approaches the axis of the shaft and then is forced outward by the curved cam face proper. Just after the roller has passed this tail piece and when it is at its nearest position to the axis of the shaft 15, the crank or wrist pin is at its lowest position, as indicated in Fig. 4, and the machine at this time is exerting its greatest pressure on the material in the mold cavity. This main shaft 15 must, of necessity, be very strong, to sustain this pressure, which is from fifty to one hundred tons, generally, and for this reason is subject to a deflection of nearly a sixteenth of an inch at this time. This deflection, caused by the resiliency of the shaft, will cause the upper sides of the wheels 14 to be forced inwardly, and to prevent these wheels having too much play I bolt or otherwise secure to the framing 2 a wear plate 80, which is provided with a shoe 81 which is adapted to ride on an internally-projecting lug 82 on the wheel 14, and tends to hold the wheel down to its work. This shoe preferably extends in

beyond the side facing of the wheel, so as to bear more directly in a vertical line and therefore be more effective.

The operation is as follows: Suitable power being imparted to the shaft 9, the wheels 14 will be rotated through the spur wheel 11 and pinion 13. Assuming that the brick has been pressed and is resting upon the lower mold, as indicated in dotted lines in Fig. 2, the first relative change in the position of the parts will be in the actuation of the lever 17 which is just entering the fluctuation in the cam groove 16, as indicated in dotted line. By the time the roller has reached its distal point, the feed box 22 will have been forced forward, shoved the finished brick before it on to the mold table in the front of the machine, and be in a position to discharge its contents into the mold cavity, which by this time is ready to receive the same by reason of the passage of the long wing of the cam 78 from beneath the roller 55, which permits the drop box to fall. The falling of the drop box is received upon the plungers 58, and the rollers 55 gently contact with the concentric portion of the cam 78. During this time, the cross head 31 and its upper plunger have been gradually carried upward through the roller 30 running on the cam 29. After the feed box has been retracted, the cam 29 is carried forward so that its end or apex 29^a will have passed the roller 30, which will permit the cross head and its plungers to drop by reason of the slot in the lower end of the pitman 28 through which the wrist pin 27 passes. The lower plungers, having remained stationary during this period, will now be caused to rise and give a second pressure to the material in the mold cavity, by reason of the tail end 79 of the cam 78 passing under the rollers 55. The cross head is thus suspended in mid air by the contact of the upper plungers resting on the material in the mold cavity, which is the only point of support, thereby placing the combined weight of the cross head and its pendent pitmen thereon. After the tail piece has passed beyond the roller 55 and the drop box starts to move down, by reason of its gravity, the wrist pin will have been sufficiently revolved to reach the bottom of the slot in the pitman, and, taking said pitman up will force the same downwardly at an increased speed over that of the descending drop box which will cause an exceedingly great pressure to be brought upon the material by the two plungers, the upper and the lower, moving in the same direction and at different speeds, the upper moving the faster. The advantage of this resides in the fact that the material is kept moving in the mold cavity and therefore granulation is obviated. After the final pressure has been placed on the material, which is illustrated at Fig. 4, and at which time the wrist-pin is at its lowermost position, the long curved face of the cam 78 will now cause the lower molds to rise. At this time also the wrist pin will have relieved the

pitman of its pressure and will have begun to move upwardly, which causes the radially-increased curved portion of the cam 29 to contact with the roller 30 and raise the cross-head at a greater speed than the movement of the lower mold, and to such a position as shown in Fig. 2 where they will be out of the way of the feed box 22, which is now about to be actuated, the brick being raised to the surface of the mold table by the lower plungers, when the cycle of operation above given will be repeated. Should, at any time, it be necessary to remove the main shaft 15 and the cam 78 by reason of their being sprung or broken, it will be obvious that by the removal of the bridge piece and the wedges that access may be easily gained thereto. Another advantage in connection with the adjustment of the main shaft boxes resides in the fact that the height of the rise of the lower plunger may be adjusted so that they will be flush with the top of the mold box and thereby permit the brick to be easily removed therefrom by the feed box, thus obviating the necessity of the use of liners to adjust these plungers, and enabling the removal and substitution of plungers without having to contend with a nicety of adjustment relative to the mold cavity, save in the alignment thereof. The upper plungers may also be adjusted through the bearings in the upper ends of the pitman, thus doing away with liners in this instance. The convenience of these adjustments can be readily appreciated by those who have had practical experience with brick machines, when due consideration is given to the fact that heretofore in the use of liners each plunger had to be adjusted individually and that at a great disadvantage by reason of inaccessibility, while in my construction it is only necessary to loosen the jam nuts, and by moving the wedges in or out, accomplish the desired adjustment.

Having thus described my invention, what I claim and desire to secure by Letters Patent, is—

1. In a machine for pressing bricks, tiles, &c., the combination with a mold box of the upper and lower plungers adapted to operate therein, of cams for actuating the lower plungers, pitmen for actuating the upper plungers, and adjustable bearings for the cam shaft and the pitmen heads, substantially as described.

2. In a machine for pressing bricks, tiles, &c., the combination with the mold box, of the upper and lower plungers adapted to operate therein, a cam shaft and cams for operating the lower plungers, pitmen and a cross-head for operating the upper plungers, wrist pins on the cam shaft with which said pitmen have slotted connections, rollers on said pitmen, and cams on the cam-shaft for raising the upper plungers through the medium of the rollers on the pitmen; said parts being so combined and arranged that bricks are pressed by the plungers moving in the same di-

rection at different speeds, and when the upper plungers are relieved of pressure, the same are lifted in advance of the lower plungers by the engagement of the cams with the rollers on the pitmen, substantially as described.

3. In a machine for pressing bricks, tiles, &c., the combination with the mold box, of upper and lower plungers which are adapted to operate therein, said lower plungers being provided with packing strips and an oiling device, cams mounted upon a suitable shaft, for operating the lower plungers, and pitmen, which are operated by the cam shaft, for operating the upper plungers, substantially as described.

4. In a machine for pressing bricks, tiles, &c., the combination with the lower plungers and drop box, of a cam or cams for operating said box, driving wheels mounted on the ends of the cam shaft, and vertically and horizontally adjustable bearings for said shaft, substantially as described.

5. In a machine for pressing bricks, tiles, &c., the combination with the lower plungers and drop box, of a cam or cams for raising and lowering the same, driving wheels mounted on the ends of the cam shaft, and adjustable bearings for said shaft, comprising a split box having a way formed at its back and inclined ways at its upper, and lower sides, wedges adapted to operate between the inclined faces and the framing of the machine, threaded rods for operating the wedges, and jam nuts, substantially as described.

6. In a machine for pressing bricks, tiles, &c., the combination with the cam shaft for operating the drop box and lower plungers, of a bearing therefor, comprising a split box having a way formed at its back, and inclined ways on its upper and lower sides, wedges mounted in said ways, and bearing against the framing of the machine, a bridge piece extending across the journal box recess and bolted to the frame of the machine, said bridge piece being formed with an inwardly projecting portion which impinges against the split box so as to hold the same rigid against horizontal movement, and threaded rods passing through the bridge piece for operating the wedges, said rods being provided with jam nuts on each side of the bridge piece, substantially as described.

7. In a machine for pressing bricks, tiles, &c., the combination with the framing, of a main shaft, main driving wheels mounted thereon, a shaft 12, pinions 13 mounted thereon for driving the main driving wheels, a transmitting gear-wheel 11, mounted on said shaft, a shaft 9, pinion 10 mounted thereon and engaging gear-wheel 11, and adjustable bearings on the framing in which said shafts are journaled, substantially as described.

8. In a machine for pressing bricks, tiles, &c., the combination with the mold box, of the upper plungers mounted upon a cross-head, standards within which said cross-heads are mounted, pitmen connected to and adapted to

operate said cross-head, said pitmen being provided with split journal boxes and wedges on each side of said journal boxes for adjusting the position of the cross-head relative to the stroke of the pitmen, substantially as described.

9. In a machine for pressing bricks, tiles, &c., the combination with the lower plungers and drop box, of open ended cylinders mounted on said drop box, and pistons in the path of said cylinders, which pistons compress the air in the cylinders to cushion the drop box when the same falls, substantially as described.

10. In a machine for pressing bricks, tiles, &c., the combination with the lower plungers and drop box, said drop box being formed with ears upon which open-ended cylinders are mounted, and guide-bearings below and in line with said cylinders, of pistons, having shoulders below said bearings, which shoulders limit the fall of the drop box and which pistons, by confining the air in the cylinders, whence it slowly escapes, absorb the vibration due to the fall of the drop box, substantially as described.

11. In a machine for pressing bricks, tiles, &c., the combination with the drop box of open-ended cylinders, and pistons for cushioning the same upon the fall of the drop box, a pipe which connects the upper end of said cylinders, and a cock for regulating the escape of air from the cylinders, substantially as described.

12. In a machine for pressing bricks, tiles, &c., the combination with a drop box provided with open-ended cylinders, of piston stems provided with piston heads, which are in the path of said cylinders, and means for holding said piston stems and pistons in an elevated but yielding position, substantially as described.

13. In a machine for pressing bricks, tiles, &c., the combination with a drop box having open-ended cylinders mounted thereon, of piston stems provided with pistons in the path of said cylinders, said piston stems being provided with cross-beams, a weighted lever, fulcrumed to one side of said beam, and having a link connection with the connecting cross beam, substantially as described.

14. In a machine for pressing bricks, tiles, &c., the combination with the drop box, of means for limiting the fall, comprising two rods 57, having shoulders 59, against which the drop box comes in contact at its lowest position, said rods being connected by a beam 62, links pivotally connected to said beams, a weighted lever to which the other ends of the

links are connected, and means for restraining the upward movement of the free end of the lever, substantially as described.

15. In a machine for pressing bricks, tiles, &c., the combination with the drop box of the shouldered rods 57 against the shoulder of which the drop box abuts in its lower position, a weighted lever for raising said rods, a sliding collar mounted on a rod 73, a stop block surrounding said rod for limiting the upward movement of the sliding collar, and a threaded sleeve, surrounding said rod, for adjusting the position of the stop block, substantially as described.

16. In a plunger for brick presses and the like, the combination with packing strips, of a battery of springs behind the same, substantially as described.

17. In a plunger for brick machines and the like, the combination with the plunger head having channels or grooves formed therearound, of angularly-shaped packing strips, which are severed diagonally, and which fit in said grooves or channels, and means for forcing said packing strips outwardly, substantially as described.

18. In a machine for pressing bricks, tiles, and the like, the combination with the drop box, of a plunger mounted thereon, composed of a plunger head and a support for said head interposed between the same and the drop box, and a through bolt, passing through the drop box, the plunger head support, and into the plunger head.

19. In a machine for pressing bricks, tiles, and the like, the combination with the main driving wheels, having brake surfaces formed on their inner side, and brake shoes, which are extended on each side of the brake surfaces on the wheel, against which extended portions the wheels will come in contact, should too much pressure be put upon their main shaft, so as to throw their upper ends inward, substantially as described.

20. In a machine for pressing bricks, tiles, &c., the combination with the main driving wheels, having brake surfaces on their inner faces, wear plates located in close proximity to the wheel, and brake shoes, projecting from said wear plates in the path of the brake surfaces on the main driving wheel, substantially as described.

In testimony whereof I hereunto affix my signature, in presence of two witnesses, this 9th day of August, 1893.

JACOB LEONHARDT.

Witnesses:

F. R. CORNWALL,
HUGH K. WAGNER.