

No. 689,484.

Patented Dec. 24, 1901.

J. M., J., A. J. & S. A. GIMSON.

MACHINERY EMPLOYED IN THE MANUFACTURE OF BOOTS OR SHOES.

(Application filed Nov. 30, 1900.)

(No Model.)

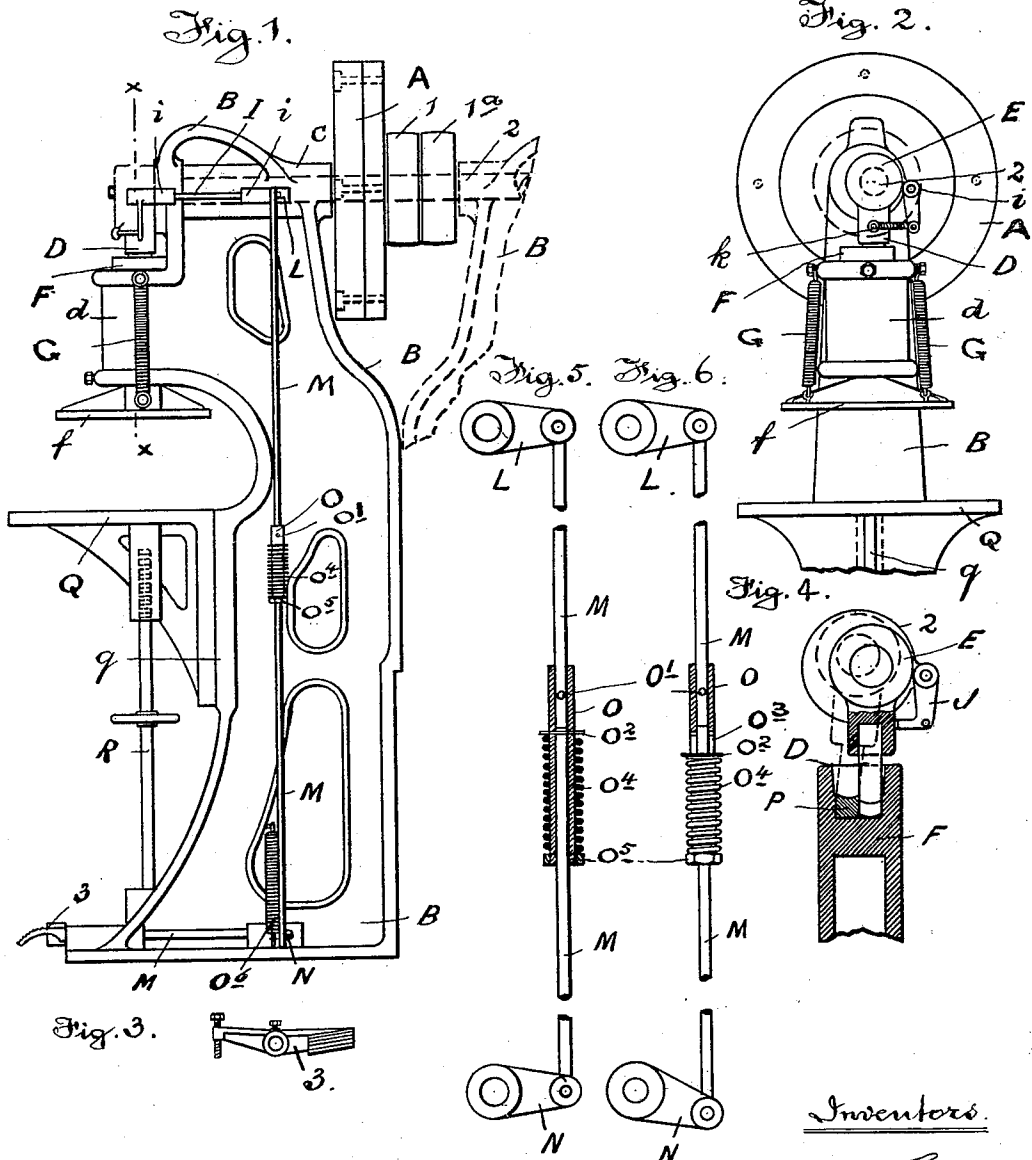

Witnesses.
 William Bramley.
 George William Coltrane.

Inventors.
 Josiah Maitor Gimson
 Josiah Gimson.
 Arthur James Gimson
 Sydney Ansell Gimson.
 per William Redwick Maxfield
 Attorney

UNITED STATES PATENT OFFICE.

JOSIAH MENTOR GIMSON, JOSIAH GIMSON, ARTHUR JAMES GIMSON, AND SYDNEY ANSELL GIMSON, OF LEICESTER, ENGLAND.

MACHINERY EMPLOYED IN THE MANUFACTURE OF BOOTS OR SHOES.

SPECIFICATION forming part of Letters Patent No. 689,484, dated December 24, 1901.

Application filed November 30, 1900. Serial No. 38,260. (No model.)

To all whom it may concern:

Be it known that we, JOSIAH MENTOR GIMSON, engineer, residing at No. 100 New Walk, JOSIAH GIMSON, engineer, residing at No. 14 Highfield street, ARTHUR JAMES GIMSON, engineer, residing at North avenue, Clarendon Park, and SYDNEY ANSELL GIMSON, engineer, residing at No. 20 Glebe street, in the borough of Leicester, England, subjects of Her Britannic Majesty Queen Victoria, have invented new and useful Improvements in or Relating to Machinery Employed in the Manufacture of Boots or Shoes, of which the following is a specification.

15 This invention refers to improvements in or relating to machinery employed in the manufacture of boots and shoes for stamping or cutting out by the aid of suitable knives, dies, or cutters, and known as "dying-out" machines. Hitherto such machines or presses have been constructed with a vertically-reciprocating buffer moving continuously up and down, the movement of said buffer being slow enough to allow the operator to slide underneath it when at its highest point a block carrying the material on which is placed the cutter or die, when at the next descent of the buffer the material is cut by the die or cutter, and after each operation the block, with the material, die, and cutter, must be moved away before the whole of the material has been cut, whereas by the means and devices herein contained the buffer remains stationary at its highest point and may be caused to descend very rapidly by the depression of the foot-lever. Therefore by the present invention it becomes only necessary to place underneath the buffer a block with the material to be cut upon it. The operator can then with safety move the die or cutter over the material and for the whole surface or extent of the buffer-plate without having to move the block or the material. Said machine is designed with the following special advantages: To increase the speed of working, so that the output may be greater; increased wearing-surfaces, with a reduction in the working parts; also, avoiding the use of toothed gearing, besides giving greater security and rendering such machines safe to the operator. These objects are attained by

the mechanism illustrated in the accompanying drawings in which—

Figure 1 is a side elevation of the machine, the broken lines indicating that two machines can be coupled together without any difficulty and form what is known as a "two-ended" machine or "double-ended press." Fig. 2 is a front elevation cut off below the movable table; Fig. 3, a side view of the foot-lever; Fig. 4, a sectional view on line *x*, Fig. 1; and Figs. 5 and 6 show the jawed lever, the divided and elongated rod, and sleeves in their normal and operative positions, respectively.

Similar letters and figures refer to similar parts throughout the several views.

The machine is known and employed either as a single or as a double ended press, the latter being obtained by making the frame of one uniform pattern or model, as shown, the compound balance-wheel A and driving-pulley 1 working both parts of eccentric shaft or shafts 2, said balance-wheel A being made in two parts, (see Fig. 1,) one half being rigidly fastened to the end of the driving-shaft of one frame and the other half to the end of the other shaft, upon which are the fast and loose pulleys 1 and 1^a. Both the frames B can then be bolted up together, the balance-wheel A secured by screwing the two parts together (indicated by the letter *b*) thus forming the "duplex" or two-ended machine known as a "double-ended press."

At or near the top of the vertical frame B is mounted the horizontal driving-shaft 2 in the bearing C and carrying the compound balance-wheel A, the driving-pulley 1, and loose pulley 1^a. Upon the front end of the shaft 2 is the arm D, depending from the eccentric E, set out from the said shaft. Below this is the bracket *d*, set out from the front of the frame to carry the buffer F, which is held upward by the springs G, arranged on each side of the buffer-head.

From the side of the head of the machine and parallel with the driving-shaft 2 is the small shaft I, carried in the lugs *i*. The front of said shaft carries the J-shaped lever J, connected to the eccentric-arm D by the spiral spring *k*, the back of said shaft carrying the jawed lever L, set out at right angles from the machine. Into the jaws of this lever is

fitted the upper end of the vertical rod M, the lower end of which is pivoted to another jawed lever N, secured on the inner end of the side shaft *m*, situated near the base of the machine, the front of said shaft carrying the foot-lever 3. The rod M is made in two parts, fitting within the sleeve O, which is rigidly fastened to the upper portion of the rod M by the pin O', passed therethrough and through the rod, the lower portion of which is free to slide in the sleeve O, the pin O² being driven rapidly through the top of the rod, and projects through two slots O³ cut in the sleeve O. Over the sleeve O is mounted the open spring O⁴, which is held up to the pin O² by the nut O⁵, screwed onto the lower end of the sleeve O.

When the foot-lever 3 is depressed and the arm or driving-bolt D strikes against the stop P, the rod M becomes elongated and causes the spring O⁴ to be compressed into the operative position, as seen in Fig. 6, Sheet 1. The further movement of the driving-shaft will then cause the arm or driving bolt D to rise until it is above the stop P, when the spring O⁴ becomes released and opens out, as seen in Fig. 5, thus causing the arm or driving bolt D to be brought over and rest upon the stop P, when the further movement of the eccentric-shaft 2 and the arm or bolt D in moving downward forces the buffer F with it to the full extent of its movement. Upon the operator releasing the foot-lever 3 the spring O⁵, secured to the frame and to the jawed lever N, contracts and immediately causes the jawed levers and rod to assume their normal positions, as seen in Fig. 5, Sheet 1, which places the driving-bolt and buffer in the position as seen in Fig. 4, Sheet 2. The springs C, as before stated, serve to keep the buffer up against the eccentric arm D on its return movement. When the buffer arrives nearly at the top of its movement, the said arm D will again leave the stop P and be

drawn across again toward the J-shaped lever J by the spring *k* and the foot-lever spring O³.

A bracket, or by preference the movable table Q, is mounted in the slot *q*, situated on the front of the frame B, which said table is vertically adjustable to and from the buffer-plate *f* by means of the hand-wheel and screw R.

Now what we claim as our invention, and desire to secure by Letters Patent, is—

In machines employed in the manufacture of boots and shoes the combination in a stamping, cutting, or dying-out press of a rotary driving-shaft, carrying a balance-wheel A, keyed to the end of said shaft, the latter carried in bearings of the frame B, in conjunction with a swinging arm or bolt D from an eccentric E set out from the driving-shaft, said arm engaging with a buffer F with buffer-plate *f*, return-springs G secured to buffer-bracket *d*, a side shaft F carrying the J-shaped lever J with spring *k* in connection with the swinging arm or bolt D, jawed levers L and N set out at right angles to the frame B and pivotally connected to the divided vertical rod M, elongated by the depression of the foot-lever 3 and spring O³, said rod carrying a sleeve O rigidly fastened to the upper portion of the rod M by the pin O', open spring O⁴ and nut O⁵; arranged and operating in the manner and for the purpose substantially as described.

In witness whereof we have hereunto set our hands in the presence of two witnesses.

JOSIAH MENTOR GIMSON.
 JOSIAH GIMSON.
 ARTHUR JAMES GIMSON.
 SYDNEY ANSELL GIMSON.

Witnesses:

WM. BRAMLEY,
 GEORGE WILLIAM COLTMAN.