

(No Model.)

2 Sheets—Sheet 1.

L. GODDU.
NAILING MACHINE.

No. 360,585.

Patented Apr. 5, 1887.

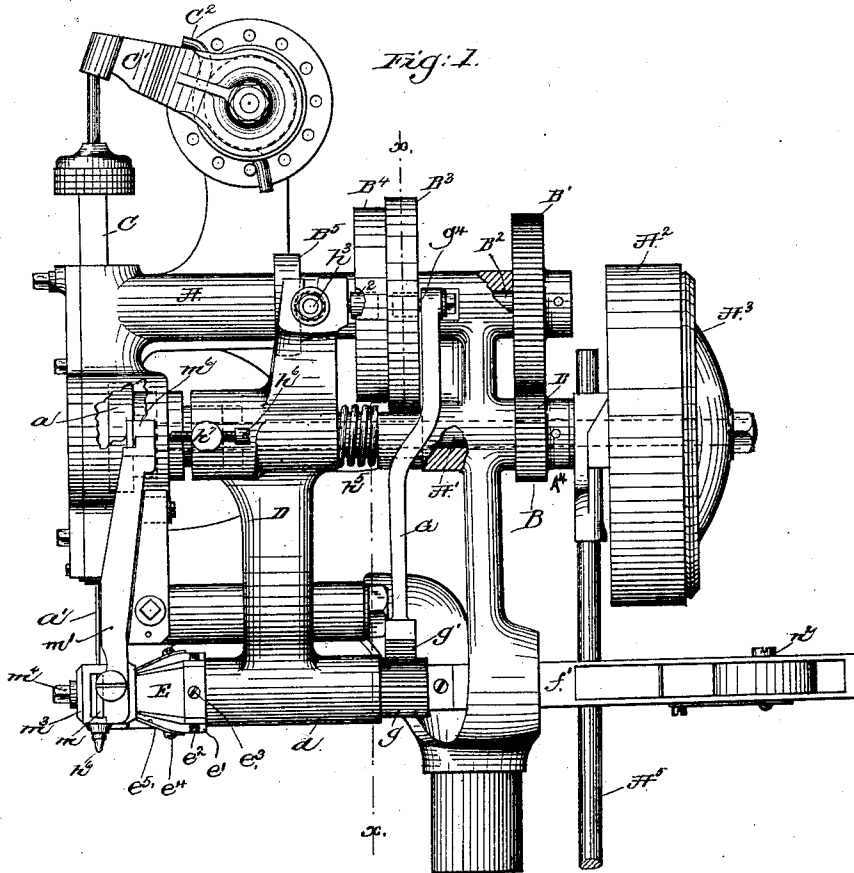

Witnesses
Frank L. Emery
John F. C. Prinslet

Inventor.
Louis Goddu
 by *Lewis Gregory*
attys.

L. GODDU.
NAILING MACHINE.

No. 360,585.

Patented Apr. 5, 1887.

Fig. 2.

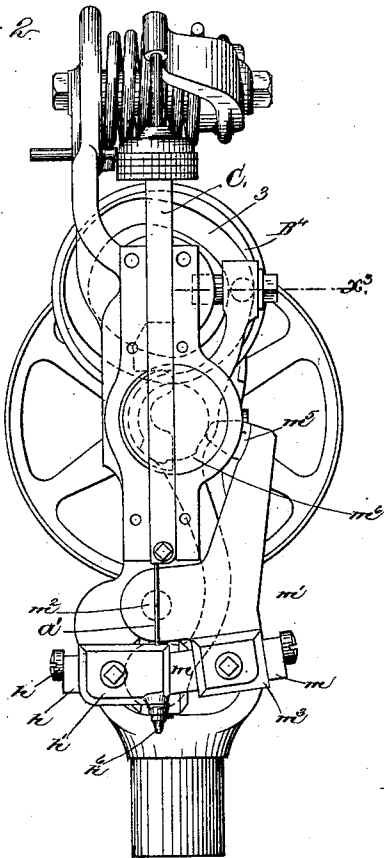

Fig. 3.

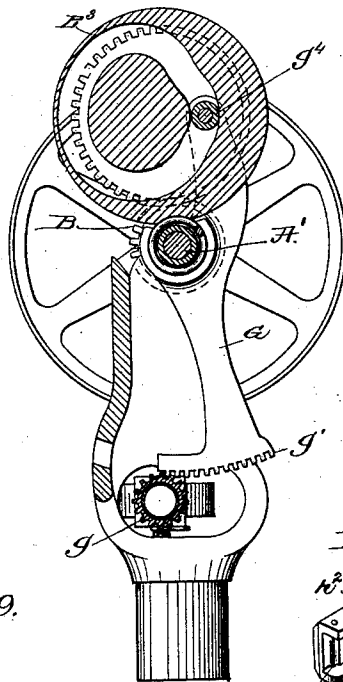

Fig. 8.

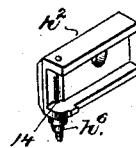

Fig. 9.



Fig. 6.

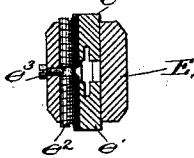

Fig. 7.

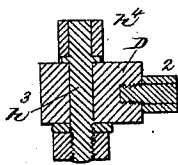

Fig. 5.

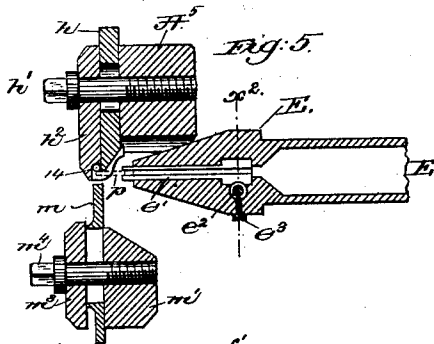
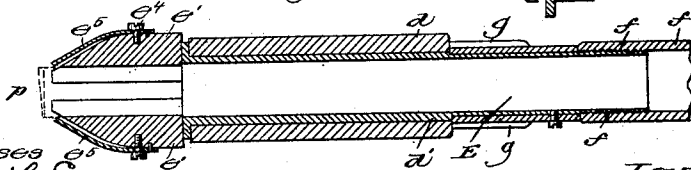

Fig. 4.



Witnesses
 Fred L. Emery
 John F. C. Prinslet

Inventor:
 Louis Goddu,
 by Leroy H. Kelly

UNITED STATES PATENT OFFICE

LOUIS GODDU, OF WINCHESTER, ASSIGNOR TO JAMES W. BROOKS, TRUSTEE,
OF CAMBRIDGE, MASSACHUSETTS.

NAILING-MACHINE.

SPECIFICATION forming part of Letters Patent No. 360,585, dated April 5, 1887.

Application filed November 26, 1886. Serial No. 219,927. (No model.)

To all whom it may concern:

Be it known that I, LOUIS GODDU, of Winchester, county of Middlesex, and State of Massachusetts, have invented an Improvement in Nailing-Machines, of which the following description, in connection with the accompanying drawings, is a specification, like letters on the drawings representing like parts.

This invention has for its object to simplify and improve that class of nailing-machines for boot and shoe work wherein the nails are made in the machine from a metal strip, the nails being severed from the strip by a transverse or diagonal cut.

In the machine herein to be described the strip or plate is held in a rotary reciprocating carrier, which is made to slide longitudinally with a pivoted vibrating frame or lever, as will be described.

The particular and especial features of my invention will be first described, and then pointed out in the claims at the end of this specification.

Figure 1, in side elevation, represents the head of a nailing-machine embodying my invention, the usual vertical post or standard to support the said head being omitted. Fig. 2 is a front end elevation of the said machine, as shown in Fig. 1; Fig. 3, a section of Fig. 1 in the dotted line xx . Fig. 4 is a longitudinal section of the carrier, the nail strip or plate being shown in dotted line. Fig. 5 is a partial horizontal section through the cutters for severing the strip or plate and the end of the carrier, as well as the parts for holding the said cutters. Fig. 6 is a section in the line x^2 , Fig. 5; Fig. 7, a section taken across the upper end of the vibrating frame or lever in which the carrier is oscillated, the section being in the line x^3 , Fig. 2. Fig. 8 is a detail of the guide or cap holding the cutter; and Fig. 9 shows a nail.

The frame-work A, of suitable shape to support the working parts, has a main shaft, A', upon which is mounted in usual manner a loose pulley, A², which co-operates as a friction-pulley with a hub or cone, A³, fast on the said shaft, the conical surface of the pulley and hub being engaged to actuate the machine at desired times by the movement of a wedge,

A⁴, carried by a rod, A⁵, all as common in nailing-machines.

The shaft A' has fast upon it a pinion, B, which engages the toothed gear B', fast on (and thus rotates) the shaft B², provided with two cam-disks, B³ B⁴, grooved, as herein shown, at their sides, and with a side or face cam, B⁵.

The front end of the shaft A' has a lifting cam, a , of such shape as to lift the driver-bar C, and at the proper time release the said bar to permit the same to be thrown down quickly by the usual arm, C', and spring C'', the driver a' , attached to the said driver-bar, acting at such time to drive the nail.

The shaft A' serves as a fulcrum for the vibrating frame or lever D, provided at its lower end with a tubular bearing, d , to receive the rounded part d' of the carrier E (see Fig. 4) for the nail strip or plate p , a part of which is shown by dotted lines at the left of Figs. 4 and 5, the said carrier having at its end a suitable nose, which is slotted, as best shown in Fig. 6, for the reception of the guides e' , the said guides being grooved longitudinally for the reception of the edges of the said nail-strip p , the said guides being made adjustable by means of a right and left threaded screw, e^2 , inserted through a part of the slotted nose and engaging screw-threads cut into one side of each of the said guides, rotation of the said screw in one or the other direction causing the simultaneous movement of the guides toward or from each other, the said screw in its rotation being prevented from being moved longitudinally by means of a screw or other suitable stud or key, e^3 , which enters an annular groove therein.

The guides $e' e'$ at their outer edges have attached to them, by suitable screws, e^4 , suitable grippers, e^5 , (shown as composed of flat springs,) the sharp corners or ends of which engage the edges of the nail strip or plate p , projected beyond the guides, the said springs bearing continually against the edges of the said strip with more or less power, the force with which they so act upon the strip being regulated by the gripper-adjusting devices e^6 . (Shown as screws.)

The strip-carrier E at its rear end has attached to it, as herein shown, by screw-threads,

as f , a strip-holder, f' , composed, essentially, of a frame of suitable shape to support a spool or other equivalent device, upon which may be coiled the nail strip or plate p , the same rotating about a suitable pivot or axis, as n^2 , the present machine being designed to use a nail strip or plate of indefinite or long length, taking the same from the said spool; or it may be a hub or reel, the said strip or plate being extended through the said carrier and beyond its nose, to be acted upon by the cutters, to be described, which act to cut the said strip into blanks or nails to be driven by the driver a' .

The carrier E has attached to it, at the rear side of the bearing d of the frame D, a pinion, g , which is engaged by a toothed sector, g' , forming part of a lever, G, the hub of which surrounds loosely the shaft A', the upper end of the said lever having a suitable roller or other stud, g^1 , which enters a groove cut in the face of the cam-disk B³, rotation of said cam-disk vibrating the said lever G, so that the sector g' , in engagement with the pinion g , effects a semi-rotation of the carrier E in one and then in the opposite direction.

The shape of the cam-groove in the cam-hub B³ (see Fig. 3) is such as to afford proper periods of rest for the carrier E, as when the feeding of the strip is taking place and the strip is being cut to form a nail.

The upper end of the frame or lever D is provided with a roller or other stud, 2, (see Figs. 1 and 7,) which enters the cam-groove 3, (see Fig. 2,) made in the cam-disk B³, the said cam-groove being of such shape as to vibrate the said lever at the proper times to move the strip-carrier toward and from the stationary cutter or blade h , attached by a suitable bolt or screw, h' , and a guide or cap, h^2 , to a stationary portion of the frame-work A. The frame or lever D also has extended through its upper end a stud, h^3 , (see Fig. 7,) which at its inner end is provided, as herein shown, with a roller, h^4 , that is acted upon by the face-cam B⁵, the said cam causing the frame or lever to be moved backward or toward the rear of the machine against the spring h^5 , placed loosely upon the shaft A', and resting at one end against the hub of the lever G.

The spring h^5 acts, normally, to keep the lever D pressed toward the front of the machine and the roll h^4 toward the face of the cam B⁵; but the extent of the forward movement of the said lever D toward the front of the machine is regulated by a screw, h^6 , in a lug, h^7 , attached to or forming part of the said lever, the end of the said screw abutting against a stationary part of the frame-work.

The longitudinal movement of the frame or lever D by the cam B⁵ and spring h^5 effects the feeding of the nail strip or plate, and the extent of such feeding movement is regulated by adjusting the screw h^6 , it being adjusted according to the width of the blank to be cut or the nail to be made and driven.

The movable cutter m , to co-operate with the stationary cutter h , is clamped firmly to

the lower end of the cutter-carrying lever m' , pivoted at m^2 by means of a cap, m^3 , and a screw or bolt, m^4 .

The upper end of the cutter-carrying lever m' has a toe, m^5 , which at each rotation of the shaft A' is acted upon by a cam, m^6 , of such shape (see dotted lines, Fig. 2) as to cause the nail strip or plate p beyond the delivery end of the carrier to be grasped and held while the frame or lever D is moved backward by the face-cam B⁵, and by the time that the backward movement of the said frame or lever is completed the said cutters m and h act to sever the nail strip or plate, the frame or lever and carrier in its backward movement over the strip or plate while held stationary by the cutters resulting in leaving a portion of the said strip extending beyond the guides e' and beyond the grippers, the latter at each time acting upon the edges of the strip and preventing any backward movement of the strip with the carrier. When the carrier is moved to the left or forward, (viewing the drawings, Fig. 1,) the grippers, by their pressure upon the edges of the strip, act to carry the said strip forward with the carrier.

The guide or cap h^2 , besides holding the cutter h in place, is so shaped (see Fig. 8) as to form a guide for the nail as the latter is cut off from the strip, the said guide having upper and lower flanges, which embrace the upper and lower sides of the cutter h .

The upper flange of the guide or cap h^2 is provided with a hole for the descent of the driver, and the lower flange has screwed into or otherwise attached to it the foot h^6 or tube, through which the blank or nail is driven into the shoe or other article upon which the said foot rests, the said shoe in practice being supported in any usual manner common to nailing-machines for boot and shoe work. The main body of the guide or cap between the said flanges is provided with a suitable shoulder, as 14, toward which the cutter member m moves to cut off a blank for a nail, the straight dull end of the said cutter m acting to form one side of a guide, of which the shoulder 14 forms another part, for the guidance of the severed blank or nail, while the driver a' descends to hit and drive the blank or nail through the tube h^6 into the stock.

In order to give a taper in one direction to the nails cut from the nail-strip p , which is of uniform thickness, the edges of the cutters h and m are set diagonally with relation to a vertical line. The greater the divergence of the cutters from a vertical line the greater the taper of the nail. The nails are cut in such manner that the heads come alternately from the opposite edges of the strip.

As the strip p , acted upon by the cutters m and h , is severed to form a nail, the said nail is frequently twisted or slightly bent; but the said nail is subsequently straightened by the passage of the edge of the cutter m beyond the corner of the cutter h , (see Fig. 7,) the cutter m being adapted to force the cut nail into the groove

in the cap h^2 , thereby straightening it and holding it in the line of descent of the driver until just before the driver hits the said nail, when the cutter m is withdrawn to release the nail and open or free the passage for the driver.

I claim—

1. In a nailing-machine, a driver-bar, a driver, and two cutters, combined with a rotary strip-carrier, and with means to hold a nail-strip wound into a coil and cause it to be rotated in unison with the said carrier, the parts being arranged to operate all substantially as described.

2. The driver-bar, driver, cutter member h , and cap provided with a guide and a foot, h^2 , for the passage of the severed blank or nail from the machine into the stock to be united, combined with the movable cutter and means to move it, substantially as described.

3. In a nailing-machine, the driver-bar, driver, the two cutter members h and m , and means to operate the cutter m , combined with the strip-carrier, and with the frame or lever D, and means to both vibrate and reciprocate it, substantially as described.

4. In a nailing-machine, the rotary strip-carrier, grippers to hold the strip, and the

frame or lever to receive the carrier, and means to both vibrate and reciprocate it, and the cutters to hold the strip, combined with means to reciprocate the said frame or lever and the carrier longitudinally to effect the feeding of the strip longitudinally through the carrier, substantially as described.

5. In a nailing-machine, the cutters, the carrier, the lever D to hold it, means to move the said lever longitudinally, and the grippers, combined with a spring to move the said frame or lever forward toward the cutters, substantially as described.

6. In a nailing-machine, the cutter h and the cap having a recess for the reception and guidance of the nail, combined with the cutter m and with means to actuate it to first cut the metal strip to form a nail and then to press it into the said recess to straighten the nail, substantially as described.

In testimony whereof I have signed my name to this specification in the presence of two subscribing witnesses.

LOUIS GODDU.

Witnesses:

G. W. GREGORY,
F. L. EMERY.