

G. B. Brayton,

Slide Valve.

No. 107,863.

Patented Oct. 4, 1870.

Fig. 2.

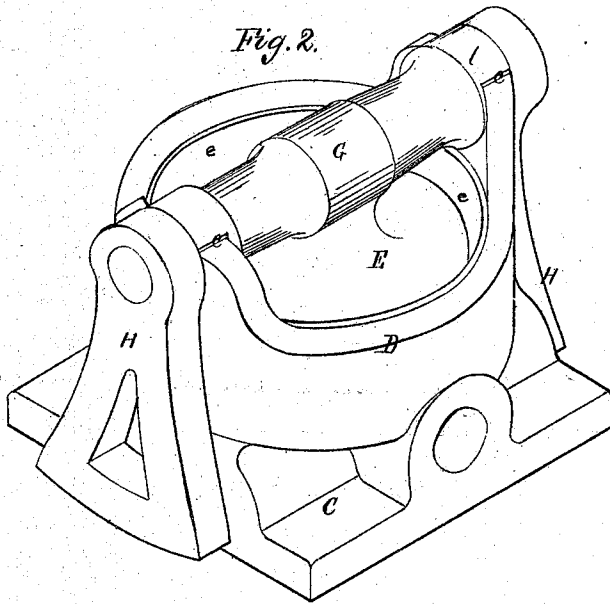
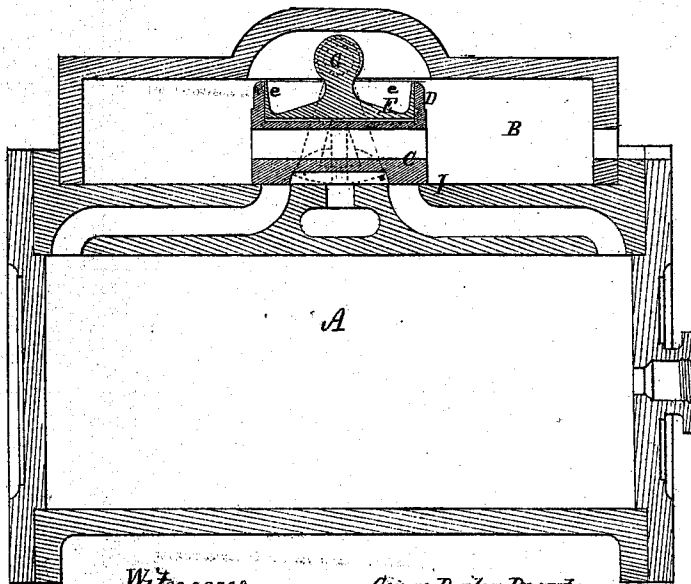

Fig. 1.



Witnesses
G. Griffith
A. Fuller
George Bailey Brayton
by his Attorney
Frederick Curtis

United States Patent Office.

GEORGE BAILEY BRAYTON, OF BOSTON, MASSACHUSETTS.

Letters Patent No. 107,863, dated October 4, 1870.

IMPROVEMENT IN SLIDE-VALVES.

The Schedule referred to in these Letters Patent and making part of the same.

To all to whom these presents shall come:

Be it known that I, GEORGE BAILEY BRAYTON, of Boston, in the county of Suffolk and State of Massachusetts, have made an invention of novel and useful Improvement in Slide-Valves; and do hereby declare the following to be a full, clear, and exact description thereof, due reference being had to the accompanying drawing making part of this specification, and in which—

Figure 1 is a vertical and longitudinal section of a cylinder, steam-chest, and valve of a steam-engine embodying my improvements.

Figure 2 is a perspective representation of said valve.

This invention relates to means for lessening or removing the friction between a slide-valve and its seat, heretofore resulting from the downward pressure of steam or other fluids upon such valves; or, in other words, to produce what is termed by mechanics a "balanced slide-valve."

This invention consists in the combination, with a slide-valve, of a plunger, fitting within a recess or well, formed in the upper part of the same, and suspended from a shaft supported upon upright sectoral plates or rocking bearings, which rest upon the valve-seat, and serve to uphold the plunger, in the manner hereinafter set forth.

The drawing before alluded to as accompanying this specification, and which illustrates one practical mode of carrying out the objects of my invention, represents at A the cylinder, and at B the steam-chest of a steam-engine, such parts being constructed and arranged in a manner identical with that now generally practiced, with this distinction only, that, in some instances, the adoption of my improvements might necessitate a slightly-increased height of the center of such steam-chest.

The slide-valve, introduced in the drawing and exhibited at C, is of the ordinary nature, so far as its steam-cavity or passage, and its relation to the steam-chest and cylinder-ports, are concerned.

In pursuance of the purposes of my present invention, and in one practical form in which the same may be carried out, I erect upon the upper surface of the valve, and monopolizing (with its plunger hereinafter referred to) the greater portion of the steam-pressure area thereof, an upright cylindrical well or inclosure, D, the top of the valve constituting the bottom of such inclosure or well, and pierced with one or more orifices, to permit of escape of steam or water which may find its way inadvertently below the auxiliary or compensating portion of the valve.

This last-mentioned object is represented in the drawing, at E, as a horizontal circular disk or block, or, what is more desirable, a cup-shaped plunger, of such

size as to fill the well D, this plunger being suspended from or making part of a cross-head or rocker-shaft, G, surmounting and spanning the well at right angles to the path of movement of the valve, and connected with the well by sliding boxes, or their equivalents, which inclose or make part of its opposite ends, such boxes or the ends of the shafts being supported in ways or guides c c, created in opposite sides of the wall of the well, and fitting therein with considerable friction.

The cross-head or shaft G may be dispensed with, and the supports of the plunger be applied at opposite sides of the same; but, for obvious reasons of strength and stiffness or steadiness, I prefer to retain the cross-head, or its equivalent.

To each outer extremity of the cross-head or shaft G, I affix or pivot, as the case may be, two upright sectoral plates or rocking bearings, H H, disposed upon opposite sides of and in parallelism with the path of travel of the valve, and resting upon the valve-seat I, and serving to support the plunger E within the well D.

In practice, it will undoubtedly be found desirable to produce, either upon the valve or valve-seat, a number of stops, in order to insure the correct relationship of the same and the supports H H, which might otherwise, by accidental lifting of the valve proper, be deranged.

In order to guard against undue passage of steam or other fluid between the plunger and its receptacle, the encompassing wall or flange e of the latter should be reduced in thickness to such an extent as to permit of its expansion under pressure of steam, and thus seal the joint between the two, and present, by this means an impassable barrier to the passage of steam. This function of the plunger obviates the necessity of an artificial packing.

As, by the division of the direct steam-pressure surface of the valve consequent upon the adoption of the plunger, or its equivalent, and the comparatively frictionless mode of supporting the latter, I am enabled to remove from the valve proper the pressure of steam which drives it upon its seat, less the amount required to maintain it in contact therewith, the only resistance to be overcome in operating the valve is that due to the friction upon the supports of the plunger, and between the valve and seat, both of which are very slight.

As these results are an economy in expenditure of power necessary to drive the valve, in lessening to a great and valuable extent the wear between the valve and seat, with consequent saving of steam, and in relieving the valve-eccentrics from wear and strain, and as the importance and value of such results are well known to persons conversant with the use of steam-

engines, and have so often been commented upon in other patents, an elaboration of these points is considered unnecessary in this specification.

That the invention will accomplish the results claimed will be apparent at a glance.

In calculating the proportions of the various parts of a valve constructed as contemplated under my invention for use of locomotive or non-condensing engines, due regard should be had to the upward pressure of exhaust steam upon the under side of the valve, or the same and the bottom of the plunger, provided a passage for steam through the valve and against such bottom exists, as hereinbefore mentioned.

In those engines where no appreciable upward pressure ensues from the exhaust, the relative proportions of the parts will be varied somewhat from that last mentioned, being governed by the degree of upward pressure to which the valve may be subjected.

These points, however, are details of construction

which in nowise influence the character of my invention as a principle.

Claim.

Having thus explained the nature and purposes of my invention,

I claim—

The combination, with the slide-valve and recess or well formed in the same, of the plunger fitting said recess, the shaft G, or other device for supporting the plunger, as described, and the sectoral plates or rocking bearings H, said parts being arranged for joint operation within the valve-chest, as shown and set forth.

GEO. BAILEY BRAYTON.

Witnesses:

FRED. CURTIS,
EDWARD GRIFFITH.