



(51) International Patent Classification:

**B64G 1/64** (2006.01)      **B25J 15/08** (2006.01)  
**B25J 11/00** (2006.01)      **B64D 1/00** (2006.01)

(21) International Application Number:

PCT/CA2013/050227

(22) International Filing Date:

19 March 2013 (19.03.2013)

(25) Filing Language:

English

(26) Publication Language:

English

(30) Priority Data:

61/612,715      19 March 2012 (19.03.2012)      US

(71) Applicant: **MACDONALD DETTWILER & ASSOCIATES INC.** [CA/CA]; 9445 Airport Road, Brampton, Ontario L6S 4J3 (CA).

(72) Inventors: **ROBERTS, Paul**; 20 Maltby Court, Brampton, Ontario L6P 1A5 (CA). **WHITE, Jason**; 6 St. Marks Road, Toronto, Ontario M6S 2H6 (CA). **FISHER, Steve**; 40 Dr. Jones Drive, Schomberg, Ontario L0G 1T0 (CA). **REMBALA, Richard**; 56-113 The Queensway, Toronto, Ontario M4V 5B6 (CA).

(74) Agent: **HILL & SCHUMACHER**; 264 Avenue Road, Toronto, Ontario M4V 2G7 (CA).

(81) Designated States (unless otherwise indicated, for every kind of national protection available): AE, AG, AL, AM, AO, AT, AU, AZ, BA, BB, BG, BH, BN, BR, BW, BY, BZ, CA, CH, CL, CN, CO, CR, CU, CZ, DE, DK, DM, DO, DZ, EC, EE, EG, ES, FI, GB, GD, GE, GH, GM, GT, HN, HR, HU, ID, IL, IN, IS, JP, KE, KG, KM, KN, KP, KR, KZ, LA, LC, LK, LR, LS, LT, LU, LY, MA, MD, ME, MG, MK, MN, MW, MX, MY, MZ, NA, NG, NI, NO, NZ, OM, PA, PE, PG, PH, PL, PT, QA, RO, RS, RU, RW, SC, SD, SE, SG, SK, SL, SM, ST, SV, SY, TH, TJ, TM, TN, TR, TT, TZ, UA, UG, US, UZ, VC, VN, ZA, ZM, ZW.

(84) Designated States (unless otherwise indicated, for every kind of regional protection available): ARIPO (BW, GH, GM, KE, LR, LS, MW, MZ, NA, RW, SD, SL, SZ, TZ, UG, ZM, ZW), Eurasian (AM, AZ, BY, KG, KZ, RU, TJ, TM), European (AL, AT, BE, BG, CH, CY, CZ, DE, DK, EE, ES, FI, FR, GB, GR, HR, HU, IE, IS, IT, LT, LU, LV, MC, MK, MT, NL, NO, PL, PT, RO, RS, SE, SI, SK, SM, TR), OAPI (BF, BJ, CF, CG, CI, CM, GA, GN, GQ, GW, ML, MR, NE, SN, TD, TG).

Published:

- with international search report (Art. 21(3))
- before the expiration of the time limit for amending the claims and to be republished in the event of receipt of amendments (Rule 48.2(h))

(54) Title: SPACECRAFT CAPTURE MECHANISM

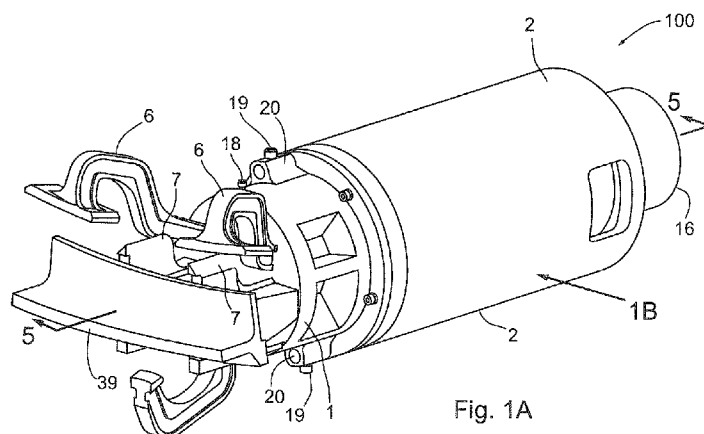

Fig. 1A

(57) Abstract: The present invention provides a capture mechanism for capturing and locking onto the Marman flange located on the exterior surfaces of spacecraft/satellites. The capture mechanism achieves its goal of quickly capturing a target spacecraft by splitting the two basic actions involved into two separate mechanisms. One mechanism performs the quick grasp of the target while the other mechanism rigidises that grasp to ensure that the target is held as firmly as desired. To achieve a speedy grasp, the grasping action is powered by springs and an over-centre mechanism triggered either mechanically by a plunger or electronically by sensors and a solenoid. This forces two sets of jaws, one on either side of the object to be grasped, to close quickly over the target object. The jaws can be set up to grasp gently, firmly, or even not close completely on the target. The key is that they must close tightly enough so that the protrusions on the target cannot escape from the jaws due to any possible motions of the target. Once the jaws have sprung shut, a second mechanism draws the jaws (and their closing mechanism) back into the body of the tool pulling the captured target onto two rigidisation surfaces. The mechanism keeps pulling backwards until a pre-established preload is reached at which point the target is considered suitably rigidised to the capture mechanism.



## **SPACECRAFT CAPTURE MECHANISM**

### **FIELD OF THE INVENTION**

The present invention relates to mechanisms for capturing spacecraft, and more particularly the present invention relates to a capture device for capturing and rigidising a bracket mounted on a spacecraft.

### **BACKGROUND OF THE INVENTION**

Grappling free flying target objects in space involves systems which possess the following capabilities: acquiring the relative location of the target object's position is relative to the capture mechanism, establishing and tracking the relative motion of the target and capture mechanism, effecting a timely reduction in the relative separation between the two objects and then acting to capture the target object fast enough that it is grasped by the capture mechanism before the target moves out of the way on its own or is knocked away by the capture mechanism (an event known as "tip off"). The methods by which the relative positions and motions of the capture mechanism and the target object are established and tracked and the methods by which the capture mechanism is moved into position to capture are not part of this description. In general these may be accomplished through the orbital and attitude control of the capture spacecraft and in some cases augmented with manipulator arms which provide further dexterity and speed in the final stage of approach and positioning of the capture device with respect to the spacecraft which is to be captured, all these techniques are well known to those skilled in the art. .

Capture mechanisms do however play a part in how large the relative movement can be between the target object and the capture mechanism. The faster the capture mechanism can perform an initial capture, the greater the relative motion can be between the two objects. This is because if the mechanism acts quickly enough, the target will have less time to move out of the way. For a given mechanism, the faster it works, the faster the relative motions can be between target object and capture mechanism. Providing a capture mechanism that permits a greater relative motion between the capture mechanism and the target object has significant benefits to both objects.

### **SUMMARY OF THE INVENTION**

The capture mechanism disclosed herein is designed with a view to capturing several of the standard spacecraft Marman clamp flange interfaces (see attached interface documents for specific variations). The vast majority of satellites launched for Western customers, both commercial and military, use this interface due to its heritage and reliability. That said, the capture mechanism disclosed herein can be used to quickly capture other target spacecraft protrusions, the key criteria being the ability of the mechanism jaws to close on the protrusion from both sides and that, when closed, at least one side of the target protrusion has an extended profile that at least one of the two jaws can get behind with which to contain the target. Examples of potentially suitable target profiles would include, but not be limited to, personnel handles and grab rails, I-beams and C-channels, T-fittings, pipes, structural members, etc.

The capture mechanism achieves its goal of quickly capturing a target spacecraft by splitting the two basic actions involved into two separate mechanisms. One mechanism performs the quick grasp of the target while the other mechanism rigidises that grasp to ensure that the target is held as firmly as desired. To achieve a speedy grasp, the grasping action is powered by springs and an over-centre mechanism triggered either mechanically by a plunger or electronically by sensors and a solenoid. This forces two sets of jaws, one on either side of the object to be grasped, to close quickly over the target object. The jaws can be set up to grasp gently, firmly, or even not close completely on the target. The key is that they must close tightly enough so that the protrusions on the target cannot escape from the jaws due to any possible motions of the target. Once the jaws have sprung shut, a second mechanism draws the jaws (and their closing mechanism) back into the body of the tool pulling the captured target onto two rigidisation surfaces. The mechanism keeps pulling backwards until a pre-established preload is reached at which point the target is considered suitably rigidised to the capture mechanism.

Another embodiment includes a system for capturing a rail and or flange feature on a free flying spacecraft, comprising

- a) a capture mechanism including a two stage grasping tool including
  - i) a quick grasp mechanism mounted for movement in a housing, said quick grasp mechanism configured to clamp said feature when said feature is in close proximity to, and triggers, said quick grasp mechanism to soft capture the feature;

ii) a rigidizing mechanism configured to draw the quick grasp mechanism and soft captured feature into said housing till said feature abuts against a rigidisation surface located in said housing to rigidize the feature and spacecraft against said housing.

In this aspect the system may include

a) a positioning device attached to the capture mechanism capable of positioning the capture mechanism into close proximity to the feature to trigger the quick grasp mechanism; and

b) a sensing system for ascertaining a relative position of the capture mechanism and the feature.

In addition, the system may include a computer control system connected to said sensing system and programmed to position the capture mechanism in close proximity to said feature to trigger said quick grasp mechanism.

An embodiment of a capture mechanism disclosed herein includes

a) a first housing section, a quick grasp mechanism mounted in said first housing section, said quick grasp mechanism including

clamping jaws having proximal sections pivotally mounted to a front portion of said first housing section and extending outwardly from a front of said first housing section,

a biasing mechanism located in said first housing section configured for biasing distal sections of the clamping jaws apart, the biasing mechanism including an elongate plunger mounted for reciprocal movement along an axis of the first housing section, the biasing mechanism including a cam mechanism pivotally mounted to

said elongate plunger and configured to have a cam portion engage said clamping jaws to bias the distal sections of the clamping jaws apart when the elongate plunger is fully extended forward of the first housing section, the cam mechanism being configured so that when the elongate plunger contacts a bracket mounted to a spacecraft and is moved inwardly into said first housing section the cam mechanism pivots with respect to said elongate plunger causing the cam portions engaging said clamping jaws to move forward forcing the distal ends of the clamping jaws to pivot toward each other thereby capturing a portion of the bracket; and

b) a second housing section mounted to a back of said first housing section, a rigidisation mechanism mounted in said second housing section, said rigidisation mechanism including

a pulling mechanism connected to the elongate plunger configured to draw the elongate plunger and the clamping jaws further into the first housing section, the first housing section and cam mechanism being configured so that as the clamping jaws are withdrawn into the first housing section the cam portions engaging said clamping jaws are biased closer together, the pulling mechanism being configured to further pull the clamping mechanism into said first housing until a portion of the bracket abuts up against a rigidisation bracket to thereby rigidize the captured spacecraft to the capture mechanism.

Another embodiment of a capture mechanism for capturing a bracket mounted to a spacecraft, comprises:

a) a first housing section, a quick grasp mechanism mounted in said first housing section, said quick grasp mechanism including

clamping jaws having proximal sections pivotally mounted to a front portion of said first housing section and extending outwardly from a front of said first housing section,

a biasing mechanism located in said first housing section configured for biasing distal sections of the clamping jaws apart, the biasing mechanism including an elongate plunger mounted for reciprocal movement along an axis of the first housing section, the biasing mechanism including a cam mechanism pivotally mounted to said elongate plunger and configured to have a cam portion engage said clamping jaws to bias the distal sections of the clamping jaws apart when the elongate plunger is fully extended forward of the first housing section, the cam mechanism being configured so that when the elongate plunger contacts a bracket mounted to a spacecraft and is moved inwardly into said first housing section the cam mechanism pivots with respect to said elongate plunger causing the cam portions engaging said clamping jaws to move forward forcing the distal ends of the clamping jaws to pivot toward each other thereby capturing a portion of the bracket; and

b) a second housing section mounted to a back of said first housing section, a rigidisation mechanism mounted in said second housing section, said rigidisation mechanism including

a pulling mechanism connected to the elongate plunger configured to draw the elongate plunger and the clamping jaws further

into the first housing section, the first housing section and cam mechanism being configured so that as the clamping jaws are withdrawn into the first housing section the cam portions engaging said clamping jaws are biased closer together, the pulling mechanism being configured to further pull the clamping mechanism into said first housing until a portion of the bracket abuts up against a rigidisation bracket to thereby rigidize the captured spacecraft to the capture mechanism; and

c) a third housing, said first and second housings being reciprocally movable along a longitudinal axis of said third housing, said third housing including

i) an extension mechanism for extending said first and second housing out of said third housing a predetermined distance,

ii) a retraction mechanism for drawing said first and second housings back into said third housing, and

iii) a locking mechanism for locking said first and second housings within said third housing.

A further understanding of the functional and advantageous aspects of the disclosure can be realized by reference to the following detailed description and drawings.

### **BRIEF DESCRIPTION OF THE DRAWINGS**

Embodiments will now be described, by way of example only, with reference to the drawings, in which:



**Figure 1A** shows a perspective view of the capture mechanism of the present invention in the open position and approaching a flange located on a spacecraft;

**Figure 1B** is a side view of the capture mechanism of **Figure 1A** in the open position;

**Figure 2** shows a perspective view of the capture mechanism of **Figure 1** but from a different perspective than shown in **Figure 1**;

**Figure 3** is a perspective view similar to **Figure 1** but with the being grasped by the capture mechanism which is in the closed position;

**Figure 4** is a top view of the capture mechanism taken along arrow **4** of **Figure 3**;

**Figure 5** is a partial cross sectional of the capture mechanism in the open position taken along line **5-5** of **Figure 1A**;

**Figure 6** is a partial cross sectional of the capture mechanism in the closed position taken along line **6-6** of **Figure 3**;

**Figure 7** is an expanded view of the cross section of **Figure 6** showing the clamping jaw portion with the clamping jaws in the closed position and showing details of the retraction mechanism;

**Figure 8** is an expanded view of the cross section of **Figure 5** of the clamping jaw portion with the clamping jaws in the open position;

**Figure 9** is a perspective view of the capture mechanism shown in cross section in **Figures 8** with the jaws in the open position and absent a cam drive link so that the cam drive springs can be seen;

**Figure 10** is a partial cross sectional diagram taken along the line **10-10** of **Figure 8**;

**Figure 11** is a full cross sectional diagram taken along line **10-10** of **Figure 8d**;

**Figure 12** is a cross sectional view of an alternative embodiment of a capture mechanism in the loaded position with the clamping jaws open and ready to grasp a Marman flange;

**Figure 13** is a cross sectional view of the capture mechanism of **Figure 11** in the sprung position with the clamping jaws gripping and closed on a Marman flange;

**Figure 14** is a cross sectional view of the capture mechanism of **Figure 11** in the retracted and locked position with the clamping jaws gripping and closed on a Marman flange; and

**Figure 15** is a block diagram showing a servicing satellite equipped with the present capture mechanism for capturing a satellite; and

**Figure 16** shows a non-limiting exemplary example of a computer control system that may be used to control the actions of the robotic tool.

### **DETAILED DESCRIPTION OF THE INVENTION**

Various embodiments and aspects of the disclosure will be described with reference to details discussed below. The following description and drawings are illustrative of the disclosure and are not to be construed as limiting the disclosure. The drawings are not necessarily to scale. Numerous specific details are described to provide a thorough understanding of various embodiments of the present disclosure. However, in certain instances, well-known or conventional details are not described in order to provide a concise discussion of embodiments of the present disclosure.

As used herein, the terms, “comprises” and “comprising” are to be construed as being inclusive and open ended, and not exclusive. Specifically, when used in this specification including claims, the terms, “comprises” and “comprising” and variations thereof mean the specified features, steps or components are included. These terms are not to be interpreted to exclude the presence of other features, steps or components.

As used herein, the term “exemplary” means “serving as an example, instance, or illustration,” and should not be construed as preferred or advantageous over other configurations disclosed herein.

As used herein, the terms “about” and “approximately”, when used in conjunction with ranges of dimensions of particles, compositions of mixtures or other physical properties or characteristics, are meant to cover slight variations that may exist in the upper and lower limits of the ranges of dimensions so as to not exclude embodiments where on average most of the dimensions are satisfied but where statistically dimensions may exist outside this region. It is not the intention to exclude embodiments such as these from the present disclosure.

The capture device disclosed herein has been conceived to address two types of spacecraft/space object capture. In general, it is for capturing “non-prepared” objects. This refers to a class of client spacecraft which were not designed with purpose made features that would be used for later capture by a servicing spacecraft once the client spacecraft was in orbit. The capture device has been designed to capture through a grasping action natural features like launch adapter rings which are present on most spacecraft for the purposes of attachment to the launch vehicle prior to release on-orbit.

Other natural features such as rails would also be applicable. A secondary feature of these non-prepared spacecraft for which this proposed capture device is intended is non-cooperative spacecraft. These are client spacecraft which are no longer under standard attitude control with the spacecraft no longer held in a stable attitude, but are instead are tumbling, i.e. rotating in one or more axis with respect to their desired pointing direction. In non-tumbling capture, the rendezvousing servicer spacecraft generally is moving relative to the client on a single axis of motion. In capturing a tumbling spacecraft, the servicer spacecraft and/or its manipulator arm must close the separation between it and the client in a number of axes. This puts a premium on the capture device being able to quickly grasp the tumbling spacecraft in what is a much narrower capture zone time, generally limited by the responsiveness of the spacecraft attitude and orbital control system and the responsiveness and peak rates of the manipulator arm.

The pool of viable targets will increase with the capture mechanism mechanism's ability to more quickly capture a mechanical feature on the client over a larger range of relative motion. In addition, the spacecraft carrying the capture mechanism will not have to control its own position as precisely, which will result in less propellant being needed and less precise avionics needing to be developed resulting in lower overall mission costs.

This premium on quickly grasping the client which is potentially tumbling presents a challenge for typical robotic grippers. They must quickly close, yet produce a sufficiently high applied gripping load to ensure that the captured spacecraft remains grasped as forces/moments develop at that interface as the servicer spacecraft and manipulator arrests the relative

motion of the client. This presents a challenge for typical single action gripping devices which generally use some sort of gearing or transmission in the clamping action. In space systems, this gearing is needed because there is a need for lightweight actuators. As the gearing is increased to compensate for the low torque of the actuator, the penalty is a lower closure rate. This design trade-off in single action robotic grippers is a primary motivation for the two stage, capture device disclosed.

Broadly speaking, the capture mechanism disclosed herein achieves its goal of quickly capturing a target spacecraft by splitting the two basic actions involved into two separate mechanisms. One mechanism performs the quick grasp of the target while the second mechanism rigidises that grasp to ensure that the target is held as firmly as desired. To achieve a speedy grasp, the grasping action is powered by springs and an over-centre mechanism triggered either mechanically by a plunger or electronically by sensors and a solenoid. This forces two sets of jaws, one on either side of the object to be grasped, to close quickly over the target object. The jaws can be configured to grasp gently, firmly, or even not close completely on the target. However it is preferred that they close tightly enough so that the protrusions on the target cannot escape from the jaws due to any possible motions of the target. Once the jaws have sprung shut, a second mechanism draws the jaws (and their closing mechanism) back into the body of the tool thereby pulling the captured target onto two rigidisation surfaces. The mechanism keeps pulling backwards until a pre-established preload is reached at which point the target is considered suitably rigidised to the capture mechanism.

### **Parts List**

This embodiment of the capture mechanism tool is comprised of the following parts:

1. capture mechanism housing
2. rigidisation mechanism housing
3. rigidisation mechanism mount
4. trigger plunger
5. single jaw
6. double jaw
7. rigidisation bracket (quantity of 2)
8. motor bracket (quantity of 2)
9. motor
10. gearbox
11. collet
12. rigidisation drive shaft
13. rigidisation drive nut
14. rigidisation drive nut spacer
15. rigidisation drive spacer retaining ring
16. mechanism mount
17. mechanism mount fastener
18. capture mechanism stop pin (quantity of 2)
19. capture mechanism return pin (quantity of 2)
20. capture mechanism return spring (quantity of 2)
21. capture mechanism cam (quantity of 2)
22. cam drive link (quantity of 2)
23. plunger drive pin

24. cam drive link pivot pin (quantity of 2)
25. cam drive spring support pin (quantity of 2)
26. cam drive pin (quantity of 2)
27. plunger draw bar
28. plunger draw bar bolt (quantity of 2)
29. plunger draw bar nut (quantity of 2)
30. rigidisation preload bushing
31. rigidisation preload spring
32. rigidisation preload washer
33. rigidisation preload spring screw
34. capture mechanism frame (quantity of 2)
35. cam drive spring access plate (quantity of 2)
36. cam drive spring (quantity of 2)
37. jaw hinge pin (quantity of 2)
38. plunger reset stop ring
39. target Marman flange
40. target spacecraft

The structure of the capture mechanism will first be described and particular reference is to a feature on most spacecraft named a Marman flange but it will be understood the present capture mechanism is configured to capture any available feature on a spacecraft not necessarily intended to be grasped. Referring to **Figures 1A, 1B, 2, 3 and 4**, capture mechanism shown generally at **100** includes a capture mechanism housing **1**, a rigidisation mechanism housing **2**, and a rigidisation mechanism mount **3**. The

capture mechanism **100** includes a single jaw **5** in opposition to a double jaw **6** which are shown in the open position. Two rigidisation brackets **7** are located in the vicinity of jaws **5** and **6** and provide outer surfaces **70** against which a Marman bracket **39** abuts once it has been captured. At the other end of the housing opposite jaws **5** and **6** is located a capture mechanism mount **16**. This mount is used to attach the capture mechanism to the end of a manipulator arm. Located in front of the rigidisation mechanism mount **3** are two capture mechanism return pins **19** located on opposite sides of the housing **1** from each other. Associated with each of the return pins **19** is a capture mechanism return spring **20** located in housings below pins **19**. At the front of the capture mechanism housing **1** are two capture mechanism stop pins **18** each one located in front of one of the pins **19**. A mount **72** is located on rigidisation mechanism housing **2**.

**Figures 1A, 1B** and **2** show the capture mechanism in the open and armed position ready to capture a Marman bracket **39**, while **Figures 3** and **4** show the capture device **100** closed after capturing the Marman bracket **39**.

Referring now to **Figures 5** and **6**, the capture mechanism **100** includes two motor brackets **8**, a motor **9** mounted to brackets **8**, a gearbox **10** coupled with motor **9**, a collet **11** coupled to the gearbox **10**, a rigidisation drive shaft **12** coupled to collet **11**, a rigidisation drive nut **13** surrounding drive shaft **12**, a rigidisation drive nut spacer **14** and a rigidisation drive spacer retaining ring **15**. Rigidisation drive shaft **12** reciprocates back and forth in the rigidisation mechanism housing **2** and rigidisation drive nut **13**, rigidisation drive nut spacer **14** and ring **15** are located in the mechanism mount **16**. The



mechanism mount fasteners **17** secure mechanism mount **16** to rigidisation mechanism housing **2**.

Referring to **Figures 7** and **8**, details of the structure of the capture mechanism are shown. The capture mechanism includes:

two capture mechanism cams 21,  
two cam drive links 22  
plunger drive pin 23  
two cam drive link pivot pins 24  
two cam drive spring support pins 25  
two cam drive pins 26  
plunger draw bar 27  
two plunger draw bar bolts 28  
two plunger draw bar nuts 29  
rigidisation preload bushing 30  
rigidisation preload spring 31  
rigidisation preload washer 32  
rigidisation preload spring screw 33  
two capture mechanism frames 34  
two cam drive spring access plates 35  
two cam drive springs 36 (only visible in **Figure 9**)  
two jaw hinge pins 37  
plunger reset stop ring 38

The two capture mechanism frames **34** serve to structurally contain and support the main components of the capture mechanism **100** and are fastened together as a unit prior to being inserted with the capture mechanism

housing **1**. Within the two frames **34** the two cam drive links **22** are interleaved, and retained within a slot **103** (see **Figures 8** and **9**) in the trigger plunger **4** by the plunger drive pin **23**. The trigger plunger **4** and cam drive links **22** sit within the frames **34** with the plunger **4** free to reciprocate fore and aft and the two cam drive links **22** pivoting about two cam drive link pivot pins **26** fixed within the frames **34**. The other ends of the two cam drive links **22** are connected by the cam drive pins **26** to the two capture mechanism cams **21**. The capture mechanism cams sit within guide slots **42** (Figure 8) forming part of the surface of the frames **34**. Slots in the cam drive links **22** permit the capture mechanism cams **21** to slide fore and aft as the cam drive links **22** rotate about the cam drive link pivot pins **26**. A cam drive spring support pin **25** is inserted in each cam drive link **22** and these act to hold the two cam drive springs **36** (one being shown in **Figure 9**). These tension springs **36** act upon the cam drive links **22** and act in such a way to bring the cam drive support pins **25** closer together. This spring force creates a moment around the cam drive link pivot pins **26** to operate the mechanism. To provide access to the two cam drive springs **36** there are two cam drive spring access plates **35**, one each for the top and bottom of the mechanism.

The capture mechanism cams **21** are in contact at point **41** with the single jaw **5** and double jaw **6** along a specifically devised follower surface **43** on the two jaws. As the capture mechanism cams **21** move fore and aft the forces on the single and double jaws **5** and **6** cause them to rotate around the jaw hinge pins **37** which hold the jaws **5** and **6** into the capture mechanism **100**. The shape of the surface combined with the contact of the capture mechanism cams **21** controls the opening and closing of the two jaws **5** and **6**.

Jaw motion speeds, the extent of closure and the mechanical advantage of the jaw closing action is controlled by varying the interaction between the cam surface **41** and the jaw follower surfaces **43**.

The plunger draw bar **27** extends through slot **44** in the trigger plunger **4** and is connected to the motor brackets **8** by a bolt **28** and nut **29** on each side. Aft of the plunger draw bar **27** are, in order, the rigidisation preload bushing **30**, the rigidisation preload spring **31** and the rigidisation preload washer **32** all fastened to the trigger plunger **4** by the rigidisation preload spring screw **33**. The rigidisation preload bushing **30**, the rigidisation preload spring **31**, the rigidisation preload washer **32** and the rigidisation preload spring screw **33** serve to even out the loads imposed by the plunger draw bar **27** on the trigger plunger **4** during rigidisation, These parts also serve to compensate for any variations in component axial dimensions due to differential thermal growth should the temperature of the mechanism **100** change.

The plunger reset stop ring **38** is installed into a groove in the trigger plunger **4** in such a way that it acts as a final stop to the mechanism when it is being reset. When the plunger reset stop ring **38** contacts the aft face of the assembled capture mechanism frames **34** it provides a signal to a control system that the mechanism has been pushed forward as far as it can go. The control system then commands the motor **9** to drive the trigger plunger **4** aft a predetermined distance to create the correct operating clearance in front of the plunger draw bar **27** within slot **44** and the capture mechanism **100** is reset and ready to capture another feature

Referring to **Figures 9, 10 and 11** and given that the capture mechanism frames are free to reciprocate with the capture mechanism housing, the capture mechanism return springs **20** acts upon the capture mechanism return pins **19** which are fastened to the two capture mechanism frames **34** to bias the quick grasp mechanism in housing **1** into the forward position, aligned and ready for capture. These springs **20** ensure that the mechanism is operated in the correct sequence and that the capture mechanism frames remain in the correct axial position.

**Figure 15** is a block diagram showing those items pertaining to the capture of a client satellite in addition to the capture mechanism **100**. These include the host servicer spacecraft **400**, the client satellite **40** with bracket **39** to be captured, a robotic arm **403**, an end effector **411** coupled to the robotic arm **403**, to which the capture mechanism **100** is interfaced **and** releasibly gripped by the end effector **411**, and a communication system **410** to provide a two-way radio link **407** to Earth **408** (or space station or mother ship- whichever is the location of the teleoperation control).

In addition, the servicer spacecraft **400** includes an onboard computer control system **500** (see **Figure 16**) which may be interfaced with the capture mechanism **100**, so that it can coordinate all the components that are involved in the capture process, including the vision system **550**, robotic arm(s) **403** (if more than one capture mechanism **100** is used). This control system is also interfaced with any sensors used to determine the position and loading state of the software capture or rigidize mechanisms. These sensors may include contact or non-contact sensors used to trigger the quick grasp mechanism (in lieu of the plunger) and position sensors to determine the degree of closure of

the mechanisms using continuous means (encoders or resolvers) or discretely (using limit switches). With the presence of the computer control system **500** interfaced with the capture mechanism **100**, the capture process may be autonomously controlled by a local Mission Manager or may include some levels of supervised autonomy so that in addition to being under pure teleoperation there may be mixed teleoperation/supervised autonomy.

Referring now to **Figures 15 and 16**, an example computing system **500** forming part of the propellant resupply system is illustrated. The system includes a computer control system **525** configured, and programmed to control movement of the robotic arm **403** during the entire procedure of capturing flange **39** on the client satellite **40**.

The command and control system is also configured to control movement of the robotic arm **403** and the end effector **411** attached thereto for controlling the action of the capture mechanism **100**. This may be the same command and control system that is interfaced with the capture mechanism, for example a computer mounted on the servicer satellite which is programmed with instructions to carry out all operations needed to be performed by the servicer satellite during approach, capture/docking with the client satellite and refueling operations. It may also be a separate computer system.

Communication system **410** is interfaced with the robotic arm **403** and configured to allow remote operation (from the Earth **408** or from any other suitable location) of the vision system **550** (which may include one or more cameras), the robotic arm **403** and hence the tools. The vision system **550** may include distinct markers mounted on capture mechanism **100**.

In one form, the vision system 550 may include one or more video cameras. To improve depth perception, it may be augmented with a range finding device, such as a laser range finder or radar. The cameras of vision system **550** may be used within a telerobotic control mode where an operator controlling the servicing actions on earth or from some other remote location views distinct views of the worksite on display screens at the command and control console. In an alternative mode, the position of elements of the tool **100** or flange **39** may be determined by either a stereo camera and vision system which extracts 3D points and determines position and orientation of mechanism **100** or other relevant features on the flange **39**, satellite **401** or capture mechanism **100** from which the robotic arm **403** can be driven to desired locations according the sensed 6 degree-of-freedom coordinates. It should be noted that the term position in the context of the positioning of the servicing spacecraft with respect to the spacecraft to be captured includes the orientation of the object as well as the translation vector between the two objects, i.e. the overall relative pose of the capture feature on the client spacecraft with respect to servicer spacecraft.

The stereo camera could also be replaced with a scanning or flash lidar system from which desired 6 degree-of-freedom coordinates could be obtained by taking measured 3-D point clouds and estimating the pose of desired objects based on stored CAD models of the desired features or shapes on the refueling worksite. For those applications where the spacecraft was designed with the intention to be serviced, a simple target such as described in Ogilvie et al. (Ogilvie, A., Justin Allport, Michael Hannah, John Lymer, "Autonomous Satellite Servicing Using the Orbital Express

Demonstration Manipulator System,” Proc. of the 9th International Symposium on Artificial Intelligence, Robotics and Automation in Space (i-SAIRAS '08), Los Angeles, California, February 25-29, 2008) could be used in combination with a monocular camera on the servicing robotics to locations items of interest. Finally, the robotic arm or device used to position the capture mechanism **100** may include a sensor or sensors capable of measuring reaction forces between the capture tool and the bracket being captured. These can be displayed to the operator to aid the operator in tele-operation control or can be used in an automatic force-moment accommodation control mode, which either aids a tele-operator or can be used in a supervised autonomous control mode.

As mentioned above, computer control system **525** is interfaced with vision system **550** and robotic arm **403**. Previously mentioned communication system **410** is provided which is interfaced with the robotic arm **403** and configured to allow remote operation (from the Earth **408** or from any other suitable location) of the vision system **550** (the robotic arm **403**, robotic end effector **411**, and capture mechanism **100**). A system of this type is very advantageous particularly for space based systems needing remote control.

The end effector **411** possesses its own embedded processor (as does the robotic arm **403**) and receives commands from the servicing spacecraft computer. The end effector **411** also passes power and data from the central computer through to the capture mechanism **100** in the event there are sensors of any type, gauges or other power requiring devices.

Some aspects of the present disclosure can be embodied, at least in part, in software. That is, the techniques can be carried out in a computer

system or other data processing system in response to its processor, such as a microprocessor, executing sequences of instructions contained in a memory, such as ROM, volatile RAM, non-volatile memory, cache, magnetic and optical disks, or a remote storage device. Further, the instructions can be downloaded into a computing device over a data network in a form of compiled and linked version. Alternatively, the logic to perform the processes as discussed above could be implemented in additional computer and/or machine readable media, such as discrete hardware components as large-scale integrated circuits (LSI's), application-specific integrated circuits (ASIC's), or firmware such as electrically erasable programmable read-only memory (EEPROM's).

**Figure 16** provides an exemplary, non-limiting implementation of computer control system **525**, forming part of the command and control system, which includes one or more processors **530** (for example, a CPU/microprocessor), bus **502**, memory **535**, which may include random access memory (RAM) and/or read only memory (ROM), one or more internal storage devices **540** (e.g. a hard disk drive, compact disk drive or internal flash memory), a power supply **545**, one more communications interfaces **410**, and various input/output devices and/or interfaces **555**.

Although only one of each component is illustrated in **Figure 18**, any number of each component can be included computer control system **525**. For example, a computer typically contains a number of different data storage media. Furthermore, although bus **502** is depicted as a single connection between all of the components, it will be appreciated that the bus **502** may represent one or more circuits, devices or communication channels which link



two or more of the components. For example, in personal computers, bus **502** often includes or is a motherboard.

In one embodiment, computer control system **525** may be, or include, a general purpose computer or any other hardware equivalents configured for operation in space. Computer control system **525** may also be implemented as one or more physical devices that are coupled to processor **530** through one or more communications channels or interfaces. For example, computer control system **525** can be implemented using application specific integrated circuits (ASIC). Alternatively, computer control system **525** can be implemented as a combination of hardware and software, where the software is loaded into the processor from the memory or over a network connection.

Computer control system **525** may be programmed with a set of instructions which when executed in the processor causes the system to perform one or more methods described in the present disclosure. Computer control system **525** may include many more or less components than those shown.

While some embodiments have been described in the context of fully functioning computers and computer systems, those skilled in the art will appreciate that various embodiments are capable of being distributed as a program product in a variety of forms and are capable of being applied regardless of the particular type of machine or computer readable media used to actually effect the distribution.

A computer readable medium can be used to store software and data which when executed by a data processing system causes the system to perform various methods. The executable software and data can be stored in

various places including for example ROM, volatile RAM, non-volatile memory and/or cache. Portions of this software and/or data can be stored in any one of these storage devices. In general, a machine readable medium includes any mechanism that provides (i.e., stores and/or transmits) information in a form accessible by a machine (e.g., a computer, network device, personal digital assistant, manufacturing tool, any device with a set of one or more processors, etc.). Examples of computer-readable media include but are not limited to recordable and non-recordable type media such as volatile and non-volatile memory devices, read only memory (ROM), random access memory (RAM), flash memory devices, floppy and other removable disks, magnetic disk storage media, optical storage media (e.g., compact discs (CDs), digital versatile disks (DVDs), etc.), among others. The instructions can be embodied in digital and analog communication links for electrical, optical, acoustical or other forms of propagated signals, such as carrier waves, infrared signals, digital signals, and the like.

The present system is also configured for full autonomous operation. A fully autonomous system is a system that measures and responds to its external environment; full autonomy is often pursued under conditions that require very responsive changes in system state to external conditions or for conditions that require rapid decision making for controlling hazardous situations. The implementation of full autonomy is often costly and is often unable to handle unforeseen or highly uncertain environments. Supervised autonomy, with human operators able to initiate autonomous states in a system, provides the benefits of a responsive autonomous local controller, with the flexibility provided by human teleoperators.

The operation of the capture mechanism will now be described with reference to the feature on the spacecraft being captured as being a Marman flange **39** (but any other suitable feature could be grasped as well). The mechanism **100** will be manoeuvred into position above the target Marman flange **39** by a manipulator arm (not shown) of suitable configuration or even by manoeuvring a spacecraft to which the mechanism **100** is directly attached. The arm or spacecraft will be guided by signals returned from a vision system attached to or near the capture mechanism in response to human commands given from the ground, from a spacecraft attached to the arm, autonomously via a computer control system connected to the arm or spacecraft or a combination of both human and computer control.

When the control system has determined that the target flange **39** is within the capture envelope, the arm or spacecraft is commanded to move the mechanism forward until the mechanism is triggered. The mechanism may be triggered electronically via a contact or noncontact sensor or mechanically. In this embodiment, the mechanism is triggered mechanically.

**Figures 1 and 3** show the mechanism in the armed configuration. The mechanism is in the “armed” or “ready to capture” position when the capture mechanism cams **21** are held in the aft position by two cam drive springs **36** (also seen only in **Figure 9**) which are attached to the two cam drive links **22** (**seen only in Figure 9**). These springs keep the trigger plunger **4** pushed forward and keep the capture mechanism cams **21** pulled back within the tool. This forces the two jaws **5** and **6** to the open position. The mechanism is triggered when the trigger plunger **4** is forced back within the tool by the contact forces that occur when the mechanism is forced into the target flange

**39** as shown in **Figure 5**. As the trigger plunger **4** moves aft within the mechanism, the attached plunger drive pin **23** (shown in **Figure 7**) forces the two cam drive links **22** to rotate about the cam drive link pivot pins **24**. This motion is resisted by the cam drive springs **36** until a point where the cam drive links **22** go over centre. At that point the cam drive springs **36** try to pull the cam drive spring support pins **25** closer together causing the cam drive links **22** to rotate around the cam drive link pivot pins **24**.

As the cam drive links **22** rotate they push the capture mechanism cams **21** forwards within the cam slots **42**. The cam follower surfaces **41** on the capture mechanism cams push on the cam contact surface **43** on the single and double jaws **5** and **6** and this forces the jaws together, trapping the target flange **39**. At the same time the trigger plunger is forced aft by the cam drive springs. Sensors can be positioned within mechanism body to sense when the trigger plunger **4** has moved to provide an indication to the control system that the mechanism has been triggered. A slot **44** in the trigger plunger permits the plunger to move around the fixed plunger draw bar **27**.

**Figure 2** shows the mechanism in the closed, but not rigidised configuration. The target flange is considered “soft captured”. After soft capture has been achieved the mechanism has to be rigidised to achieve the full structural interface with the target spacecraft **40**. In this embodiment, the actuator that rigidises the mechanism is a motor contained within the tool but that actuator could be any other type of mechanical actuation, be it springs, gas generator, paraffin actuator, solenoid or even a motor in a remote location connected by a powertrain of some sort.

To rigidise the mechanism after soft capture the control system commands the motor **9** to turn which, via the gearbox **10** and collet **11** turns the rigidisation drive shaft **12**. The rigidisation drive shaft **12** turns within the rigidisation drive nut **13** which then draws the motor **9** and its motor brackets **8** further aft into the rigidisation mechanism housing **3**. The rigidisation mechanism housing **3** is connected to the plunger draw bar **27** and pulls the draw bar back with it as it moves. The plunger draw bar **27** moves within slot **44** in the trigger plunger **4**. The motor **9** pulls the draw bar aft until it contacts the rigidisation preload bushing **30** which is connected through the rigidisation preload spring **31**, rigidisation preload washer **32** and rigidisation preload spring screw **33** to the trigger plunger **4**. The rigidisation preload spring ensures that excessive tensile forces are not imposed on the rigidisation components.

The two, connected capture mechanism frames **34** are free to move within the capture mechanism housing **1**. As the trigger plunger is pulled aft by the motor it applies more torque to the two cam drive links **22** forcing the capture mechanism cams **21** even further forwards which grasps the Marman flange **39** even more securely and centres it within the jaws. Once the cams are as far forward as possible (limited by the flexibility of the jaws, the wedge angle that the closed jaws make and the forward force on the cams) the rigidisation actuator starts to pull the entire capture mechanism (jaws, frames and cams) and the captured Marman flange **39** aft via the trigger plunger **4**. The motor continues to pull the Marman flange aft until the surface of the Marman flange contacts the front face of the two rigidisation brackets **7**. Once contact has been made, the motor **9** continues to pull the quick grasp

mechanism in housing **1** aft until the control system senses, in this case, via current sensing and counting the number of drive shaft turns, that the Marman flange **39** has been drawn against the rigidisation brackets **7** with the specified amount of force. The mechanism is now considered fully rigidised with the Marman bracket **39** and spacecraft **40** rigidised against the brackets **7**.

To reset the mechanism, the motor **9** is reversed and the draw bar **27** moves forwards in slot **44** until it contacts the front of the slot and starts to push the trigger plunger forwards. As the load is removed from the capture mechanism frames **34** the two capture mechanism return springs **20** move the entire quick grasp mechanism in housing **1** forward and the Marman flange **39** is moved off of the rigidisation brackets **7**, yet is still captured by the jaws **5** and **6** in their fully closed position. The quick grasp mechanism contained in housing **1** continues to move forward until the capture mechanism frames **34** come in contact with the capture mechanism stop pins **18** which inhibit further forward movement of the quick grasp mechanism. The motor **9** continues to drive the trigger plunger **4** forward and this causes the plunger drive pin **23** to cause the cam drive links **22** to rotate and pull the two capture mechanism cams **21** aft. As the capture mechanism cams **21** move aft, first the load on the Marman flange **39** reduces and, towards the very end of cam travel, the shape of the cam follower surfaces **43** causes the jaws to open and mechanism is completely disengaged from the Marman flange **39**. With the capture mechanism frames **34** fully forward, the motor **9** continues to drive the trigger plunger **4** forward until the plunger reset stop ring **38** contacts the aft face of the capture mechanism frames **34**. At this point the cam drive links have moved back over centre and are cocked and ready to be activated

again. The increase in motor current as the motor stalls indicates to the control system that the mechanism is at the reset point. The motor is stopped and then commanded to pull the trigger plunger aft a predetermined amount to a point where, when the plunger is triggered and quickly moves aft slot **44** will not hit the front face of the draw bar **27**. The mechanism is now completely reset and ready to capture another target flange.

Thus, the present spacecraft capture mechanism is for capturing a rail and or flange feature on a free flying spacecraft. The mechanism includes a capture mechanism including a two stage grasping tool. The grasping tool includes a quick grasp mechanism mounted for movement in housing **1**, which is configured to clamp the feature when the feature is in close proximity to, and triggers the quick grasp mechanism to soft capture the feature (shown as Marman flange **39** in the figures). The quick grasp mechanism includes jaws **5** and **6**, and associated cam mechanism located in housing **1**. The capture mechanism includes a rigidizing mechanism located in housing **2** configured to draw the quick grasp mechanism and soft captured feature into housing **1** till the feature abuts against a rigidisation surface located in the first housing to rigidize the feature and spacecraft against housing **1**. As shown in **Figures 1 to 8** the rigidizing mechanism includes a pulling mechanism connected to the elongate plunger **4** configured to draw the elongate plunger **4** and the clamping jaws **5** and **6** further into the first housing section **1**, the first housing section **1** and the cam mechanism being configured so that as the clamping jaws **5** and **6** are withdrawn into the first housing section **1** the cam portions engaging the clamping jaws **5** and **6** are biased closer together. The pulling mechanism is configured to further pull the clamping mechanism

into the first housing **1** until a portion of the bracket abuts up against rigidisation brackets **7** to thereby rigidize the captured spacecraft to the capture mechanism.

A non-limiting embodiment of the pulling mechanism includes motor **9**, gear box **10** and collet **11**. The motor **9** is coupled to the trigger plunger **4** by the motor brackets **8** which are coupled through the plunger draw bar **27** to trigger plunger **4** and to the rigidisation mechanism housing **2** through the rigidisation drive shaft **12** and the rigidisation drive nut **13**.

### **Quicker-acting Capture Mechanism**

A further embodiment increases the capture speed of the device by adding an additional mechanism. This third mechanism holds the capture mechanism illustrated in **Figure 1** and couples it with a spring and, if required by spacecraft dynamics consideration, also couples it to a recoil mass to limit the reaction forces on the host spacecraft when the mechanism activates. The device is comprised of the following components shown in **Figures 12, 13** and **14**:

45. capture mechanism assembly similar to that shown in **Figure 1**.
46. main housing
47. linear bearing (qty 2 req'd)
48. capture mechanism support carriage
49. reset actuator
50. reset cable spool (qty 2 req'd)
51. reset cable (qty 2 req'd)
52. reset cable idler (qty 2 req'd)



- 53. recoil mass
- 54. recoil damper
- 55. reciprocation spring
- 56. recoil mass support carriage
- 57. recoil mass release arm
- 58. mechanism release actuator
- 59. capture mechanism release arm

**Figure 12** shows the device armed and ready to be activated. Similar to the previous embodiment, this version must be placed in a position where the target spacecraft **40** and its Marman flange **39** are within the mechanism's capture envelope by an arm or by the host/servicer spacecraft's control system. Again, this can be accomplished via direct ground control, on board autonomous computer control or by an advantageous combination of the two. Once the target Marman flange **39** is within the envelope of the device the control system commands the mechanism release actuator **58** to simultaneously release the capture mechanism assembly **45** and the recoil mass **53**. The capture mechanism is pushed forward a prescribed distance and the recoil mass **53** is pushed backwards at the same time. The capture mechanism assembly is supported by the capture mechanism support carriage **48** and the recoil mass **53** is supported by the recoil mass support carriage **56**. Both support carriages run on a set of aligned linear bearings **47** that guide the axial movement of the two sub-assemblies and connect the support carriages to the main housing **46**.

As the capture mechanism assembly reaches approximately the end of its travel, and if the computations regarding the future position of the target flange were correct when the device was triggered, then trigger plunger **4** on the capture mechanism assembly **45** will strike the surface of the target flange **39** and initiate the capture sequence outlined above. At the same time, the recoil mass **53** has hit the end of its travel and to provide a final protection against impact shock (which can be harmful to delicate spacecraft components) comes into contact with the recoil damper **54** which absorbs almost all of any remaining deceleration forces and brings the recoil mass **53** to a stop. A series of one-way brakes (not shown) in the recoil mass support carriage **56** help prevent the recoil mass **53** from rebounding back down the linear bearings **47** in an uncontrolled manner. These brakes can be of the limited slip type which would permit the recoil mass **53** to slowly move back towards the reset position or they can be rigid brakes permitting the actions of the various elements to be controlled individually. A similar set of brakes on the capture mechanism support carriage **48** prevent its uncontrolled rebound when it reaches the end of its travel. If required to limit capture mechanism assembly **45** deceleration shocks a damper similar to the recoil damper **54** can be placed in the path of the capture mechanism assembly **45**.

With the targeted area of Marman flange **39** captured in the jaws **5** and **6** of the capture mechanism assembly **45**, the capture mechanism support carriage **48** is locked to the linear bearings **47** and the capture mechanism assembly **45** rigidises its grasp of the target flange **39** as described for the basic mechanism, above. Once the target Marman flange **39** (or any other graspable feature on the client satellite) is held rigidly in the grasp of the

mechanism the capture mechanism assembly **45** may be pulled back into the device housing **46**.

Resetting the device is accomplished by engaging the reset actuator **49**, which, in this case is a motor gearbox but could as well be a clockwork, a shape memory alloy actuator, a paraffin actuator or any number of other acceptable actuators that serve to draw the capture mechanism assembly **45** and the recoil mass assembly **53** back towards their initial position. In this case the reset actuator **49** turns two reset cable spools **50** which draw in the two reset cables **51** that are attached to the two support carriages **48** and **56**. Once the capture mechanism support carriage **48** and the recoil mass support carriage **56** reach the point where the reciprocation spring **55** has achieved the correct amount of compression necessary to activate the device for the next capture attempt, the two support carriages **48** and **56** are locked into the linear bearings **47** and the capture mechanism release arms **59** re-engage connecting the mechanism release actuator **58** to the two support carriages **48** and **56**.

As a last step, the rotation of the reset spools **50** is uncoupled from the reset actuator **49** by means of a clutch or released brake (not shown) so that the reset spools **50** may quickly pay out cable the next time that capture is initiated. The capture mechanism **50** is now reset and ready to make another capture operation. The jaws **5** and **6** of the capture mechanism can be opened independently of the capture action so that the target satellite **40** can be released without initiating the reciprocating action.

There may be operational considerations that require that the target satellite be held without rigidising while the capture mechanism assembly and

this sequence of events can be supported by the device by simply changing the sequence in which the actuators are commanded. Similarly, by leaving the reset actuator **46** coupled to the reset spools **50** it can be used to slowly pay out the capture mechanism assembly **45** as opposed to the rapid capture action, should that prove advantageous.

By controlling the various masses and any braking or drag forces being applied by the two support carriages **48** and **56** to motion down the linear bearings **47**, the speeds and accelerations of the mechanism **45** can be fine-tuned. In an embodiment where actuators are included in the support carriages **48** and **56**, this fine-tuning can take place during the capture event permitting a significant level of control over the capture event.

The specific embodiments described above have been shown by way of example, and it should be understood that these embodiments may be susceptible to various modifications and alternative forms. It should be further understood that the claims are not intended to be limited to the particular forms disclosed, but rather to cover all modifications, equivalents, and alternatives falling within the spirit and scope of this disclosure.

**THEREFORE WHAT IS CLAIMED IS:**

1. A system for capturing a rail and or flange feature on a free flying client spacecraft, comprising

a capture mechanism including a two stage grasping tool including

i) a quick grasp mechanism mounted for movement in a housing, said quick grasp mechanism configured to clamp said feature when said feature is in close proximity to, and triggers, said quick grasp mechanism to soft capture the feature; and

ii) a rigidizing mechanism configured to draw the quick grasp mechanism and soft captured feature into said housing until said feature abuts against a rigidisation surface located in said housing to rigidize the feature and spacecraft against said housing.

2. The system according to claim 1, further comprising

a) a positioning mechanism releasibly attachable to the capture mechanism capable of positioning the capture mechanism into close proximity to the feature to trigger the quick grasp mechanism, said positioning mechanism being mounted on a servicer spacecraft; and

b) a sensing system for ascertaining a relative position of the capture mechanism and the feature.

3. The system according to claim 2 including a computer control system connected to said sensing system and said positioning mechanism and

programmed to position the capture mechanism in close proximity to said feature to trigger said quick grasp mechanism.

4. The system according to claim 3 further comprising a communication system configured to provide communication between said computer control system and a remote operator for remote teleoperator control, supervised autonomous control, or fully autonomous control of all capture operations between the servicer spacecraft and the client satellite.

5. The system according to claim 2, 3 or 4 wherein said sensing system includes a vision system mounted and configured to provide real time images of all capture and release operations.

6. The system according to claim 5 wherein said sensing system is connected to said communication system for transmitting said images and being configured to be used in any one or combination of teleoperation by a teleoperator, autonomous control, or a combination of both teleoperator and autonomous control.

7. The system according to claims 3, 4, 5 or 6 wherein said computer control system is further programmed to control the actions of said quick grasp and rigidizing mechanisms.

8. The system according to claims 3, 4, 5 or 6 including a second computer control system programmed to control the actions of said quick grasp and rigidizing mechanisms.
9. The system according to any one of claims 1 to 8 wherein said capture mechanism includes a first housing section in which said quick grasp mechanism is mounted, said quick grasp mechanism including
- clamping jaws having proximal sections pivotally mounted to a front portion of said first housing section and extending outwardly from a front of said first housing section,
  - a biasing mechanism located in said first housing section configured for biasing distal sections of the clamping jaws apart, the biasing mechanism including an elongate plunger mounted for reciprocal movement along an axis of the first housing section, the biasing mechanism including a cam mechanism pivotally mounted to said elongate plunger and configured to have a cam portion engage said clamping jaws to bias the distal sections of the clamping jaws apart when the elongate plunger is fully extended forward of the first housing section, the cam mechanism being configured so that when the elongate plunger contacts a bracket mounted to a spacecraft and is moved inwardly into said first housing section the cam mechanism pivots with respect to said elongate plunger causing the cam portions engaging said clamping jaws to move forward forcing the distal ends of the clamping jaws to pivot toward each other thereby capturing a portion of the bracket; and

said rigidisation mechanism being mounted in a second housing section, said second housing section mounted to a back of said first housing section, said rigidisation mechanism including

a pulling mechanism connected to the elongate plunger configured to draw the elongate plunger and the clamping jaws further into the first housing section, the first housing section and cam mechanism being configured so that as the clamping jaws are withdrawn into the first housing section the cam portions engaging said clamping jaws are biased closer together, the pulling mechanism being configured to further pull the clamping mechanism into said first housing until a portion of the bracket abuts up against a rigidisation bracket to thereby rigidize the captured spacecraft to the capture mechanism.

10. A capture mechanism for capturing a bracket mounted to a spacecraft, comprising:

a) a first housing section, a quick grasp mechanism mounted in said first housing section, said quick grasp mechanism including

clamping jaws having proximal sections pivotally mounted to a front portion of said first housing section and extending outwardly from a front of said first housing section,

a biasing mechanism located in said first housing section configured for biasing distal sections of the clamping jaws apart, the biasing mechanism including an elongate plunger mounted for reciprocal movement along an axis of the first housing section, the



biasing mechanism including a cam mechanism pivotally mounted to said elongate plunger and configured to have a cam portion engage said clamping jaws to bias the distal sections of the clamping jaws apart when the elongate plunger is fully extended forward of the first housing section, the cam mechanism being configured so that when the elongate plunger contacts a bracket mounted to a spacecraft and is moved inwardly into said first housing section the cam mechanism pivots with respect to said elongate plunger causing the cam portions engaging said clamping jaws to move forward forcing the distal ends of the clamping jaws to pivot toward each other thereby capturing a portion of the bracket; and

b) a second housing section mounted to a back of said first housing section, a rigidisation mechanism mounted in said second housing section, said rigidisation mechanism including

a pulling mechanism connected to the elongate plunger configured to draw the elongate plunger and the clamping jaws further into the first housing section, the first housing section and cam mechanism being configured so that as the clamping jaws are withdrawn into the first housing section the cam portions engaging said clamping jaws are biased closer together, the pulling mechanism being configured to further pull the clamping mechanism into said first housing until a portion of the bracket abuts up against a rigidisation bracket to thereby rigidize the captured spacecraft to the capture mechanism.

11. A satellite capture mechanism for capturing a bracket mounted to a spacecraft or satellite, comprising:

a) a first housing section, a quick grasp mechanism mounted in said first housing section, said quick grasp mechanism including

clamping jaws having proximal sections pivotally mounted to a front portion of said first housing section and extending outwardly from a front of said first housing section,

a biasing mechanism located in said first housing section configured for biasing distal sections of the clamping jaws apart, the biasing mechanism including an elongate plunger mounted for reciprocal movement along an axis of the first housing section, the biasing mechanism including a cam mechanism pivotally mounted to said elongate plunger and configured to have a cam portion engage said clamping jaws to bias the distal sections of the clamping jaws apart when the elongate plunger is fully extended forward of the first housing section, the cam mechanism being configured so that when the elongate plunger contacts a bracket mounted to a spacecraft and is moved inwardly into said first housing section the cam mechanism pivots with respect to said elongate plunger causing the cam portions engaging said clamping jaws to move forward forcing the distal ends of the clamping jaws to pivot toward each other thereby capturing a portion of the bracket; and

b) a second housing section mounted to a back of said first housing section, a rigidisation mechanism mounted in said second housing section, said rigidisation mechanism including

a pulling mechanism connected to the elongate plunger configured to draw the elongate plunger and the clamping jaws further into the first housing section, the first housing section and cam mechanism being configured so that as the clamping jaws are withdrawn into the first housing section the cam portions engaging said clamping jaws are biased closer together, the pulling mechanism being configured to further pull the clamping mechanism into said first housing until a portion of the bracket abuts up against a rigidisation bracket to thereby rigidize the captured spacecraft to the capture mechanism; and

c) a third housing, said first and second housings being reciprocally movable along a longitudinal axis of said third housing, said third housing including

i) an extension mechanism for extending said first and second housing out of said third housing a predetermined distance,

ii) a retraction mechanism for drawing said first and second housings back into said third housing, and

iii) a locking mechanism for locking said first and second housings within said third housing.

12. The mechanism according to claim 11 further including a locking mechanism to lock said first and second housings in said extended position.

13. The mechanism according to claims 11 or 12 further including a counterweight reciprocally mounted for movement in said third housing and

being configured to counteract forces generated when the first and second housings are extended from said third housing.

14. The mechanism according to claims 11, 12 or 13 wherein said extension mechanism includes a spring attached at one end to said third housing and attached at the other end to a back portion of said second housing, and including trigger mechanism for triggering the locking to allow the first and second housings to be extended from said third housing.

15. The mechanism according to claimS 11, 12, 13 OR14 wherein said retraction mechanism includes a cable and motor system mounted to said third housing with said cable being connected to said first and second housings, wherein activation of the motor withdraws the second and third housings back into the third housing.

16. The mechanism according to claims 11, 12, 13, 14 or 15 including a bearing assembly positioned between said connected first and second housings and said third housing to facilitate sliding motion of the first and second housings with respect to the third housing.

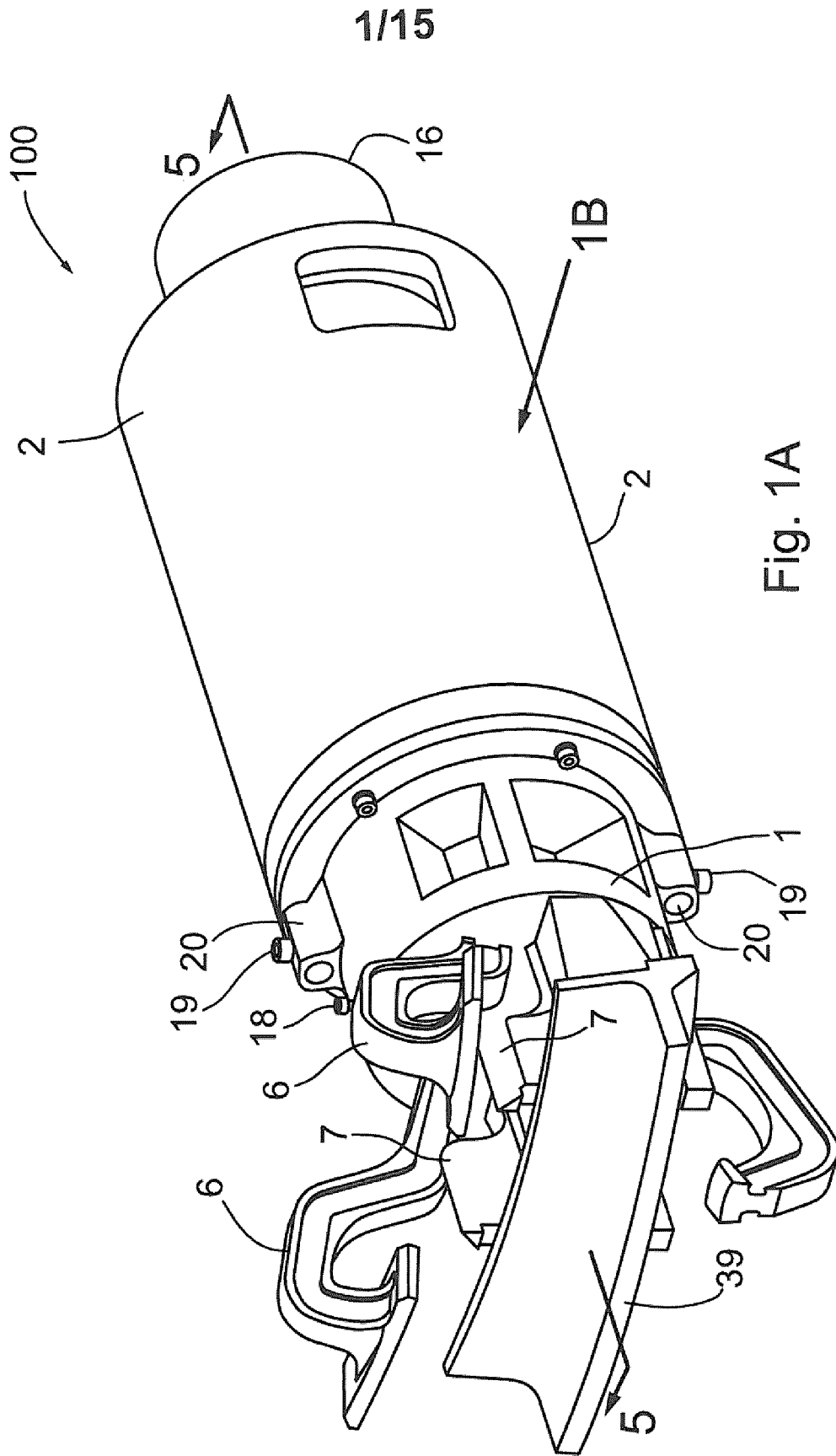

2/15

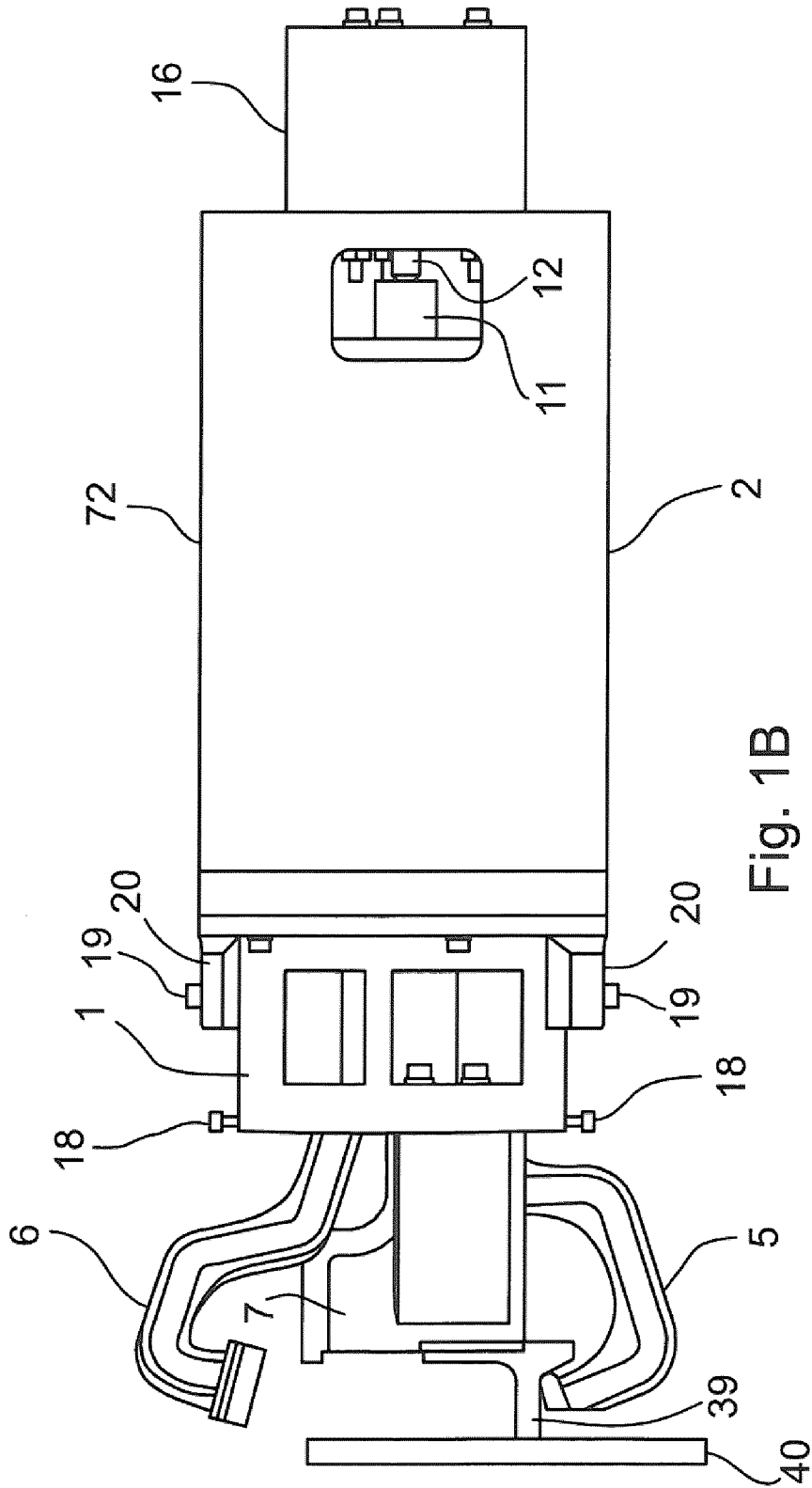

Fig. 1B

3/15

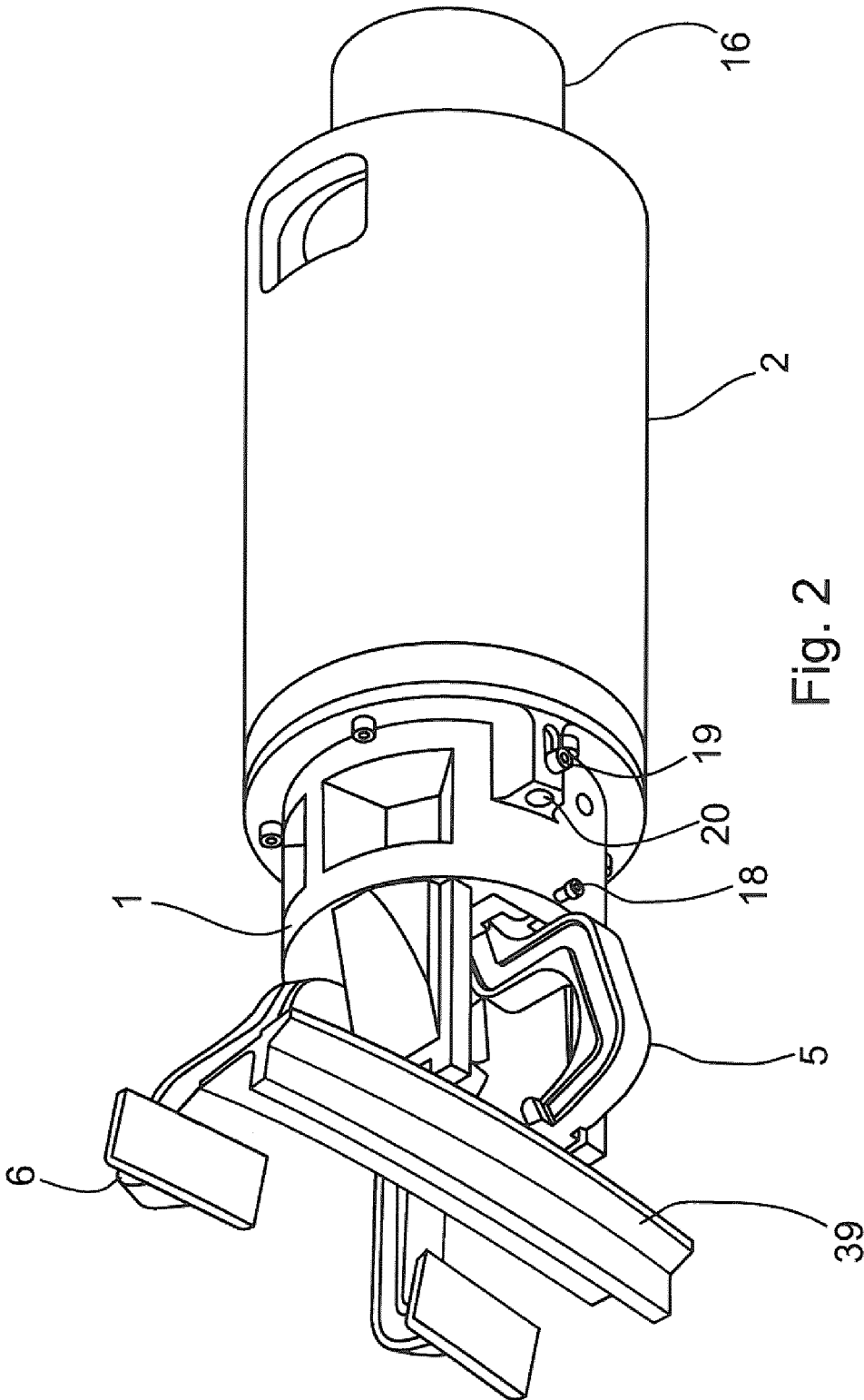

Fig. 2

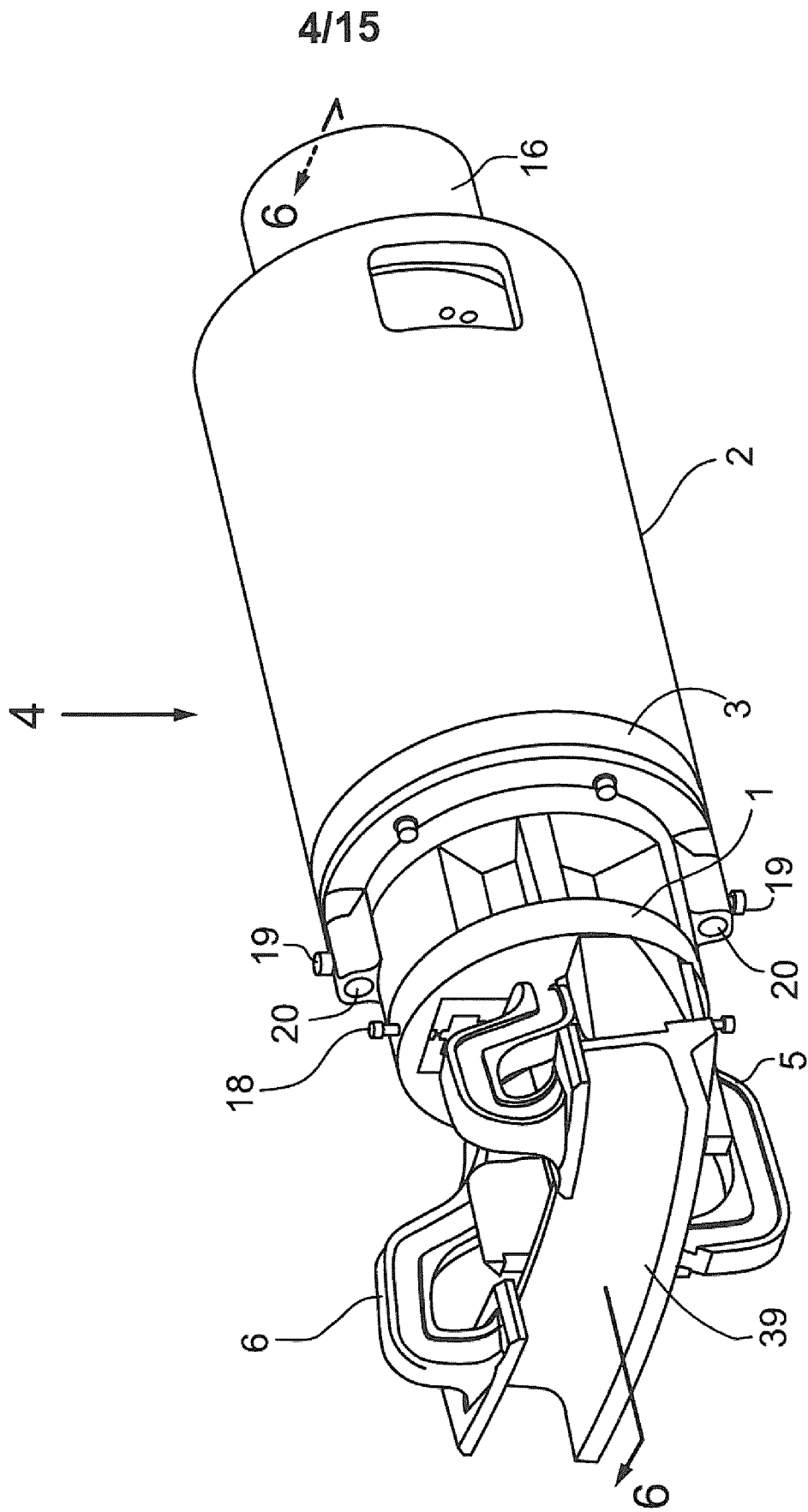

Fig. 3



5/15

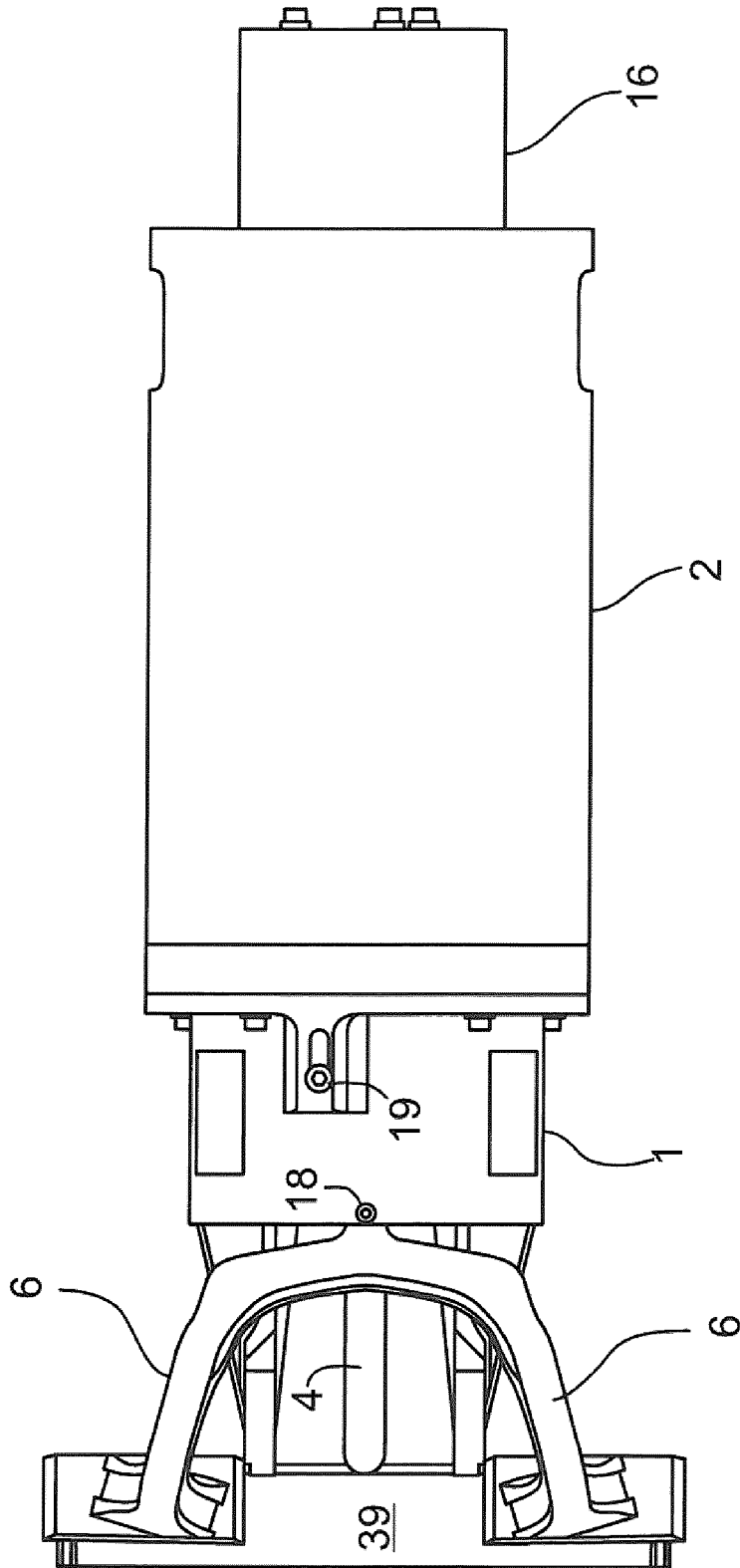

Fig. 4

6/15

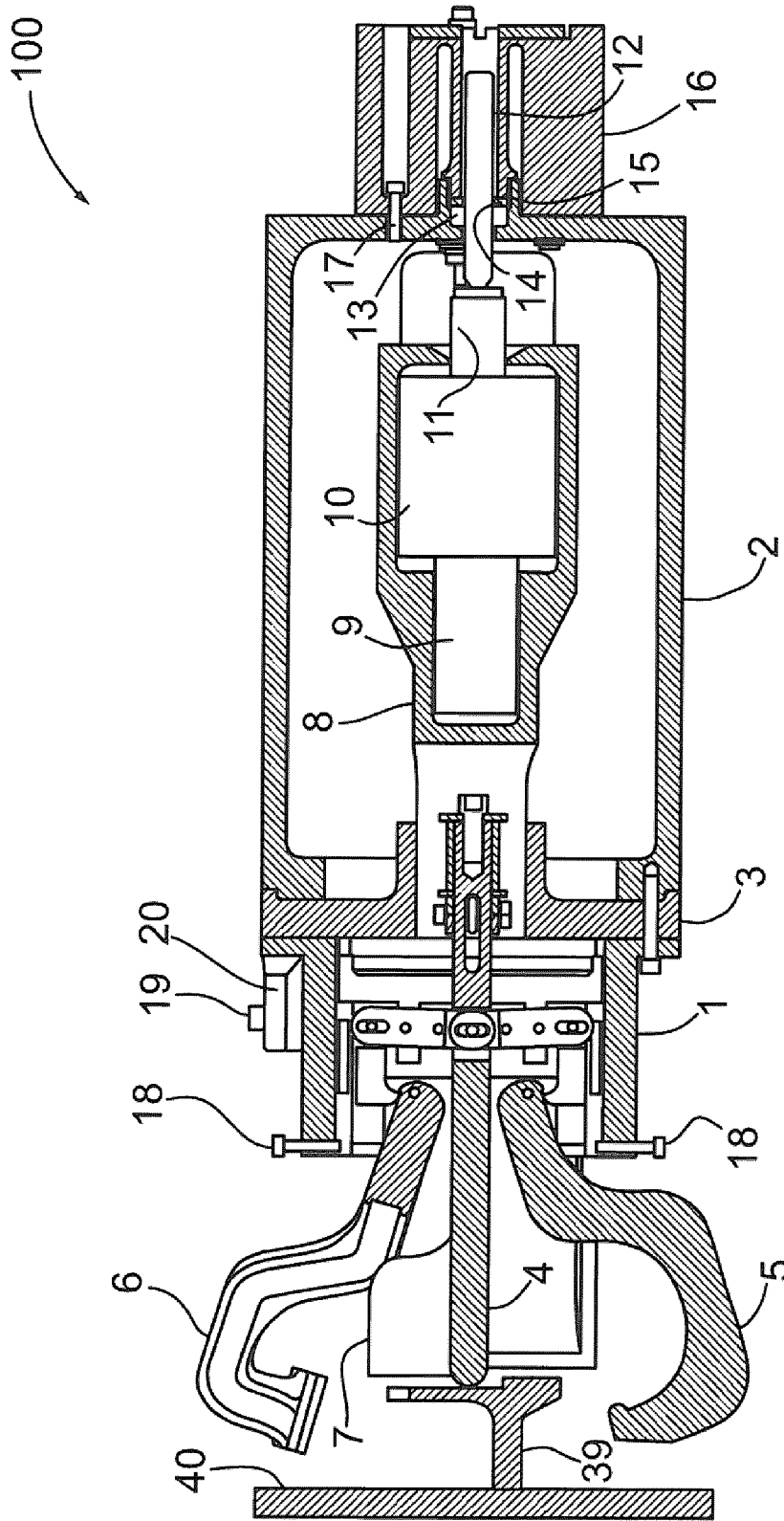

Fig. 5

7/15

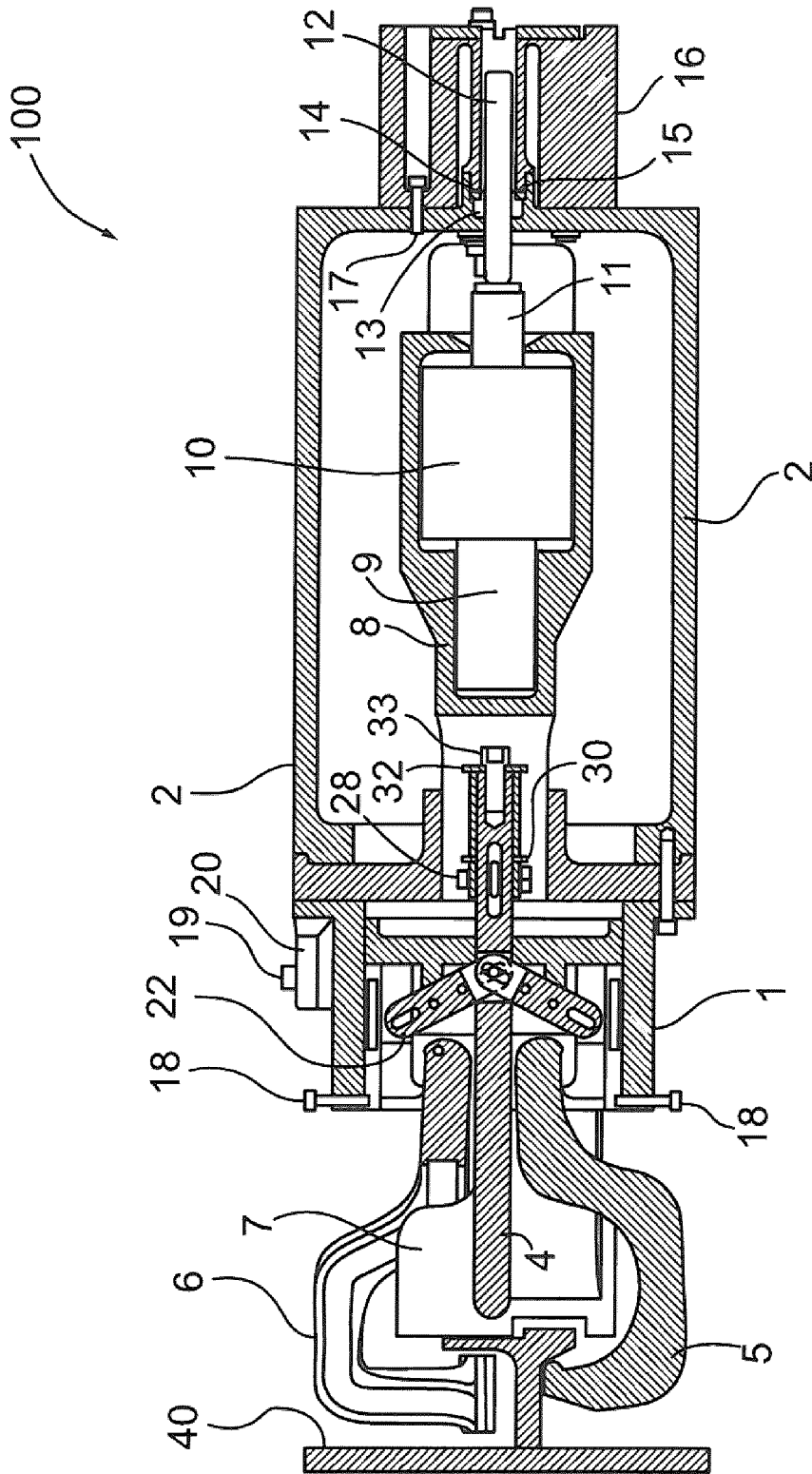
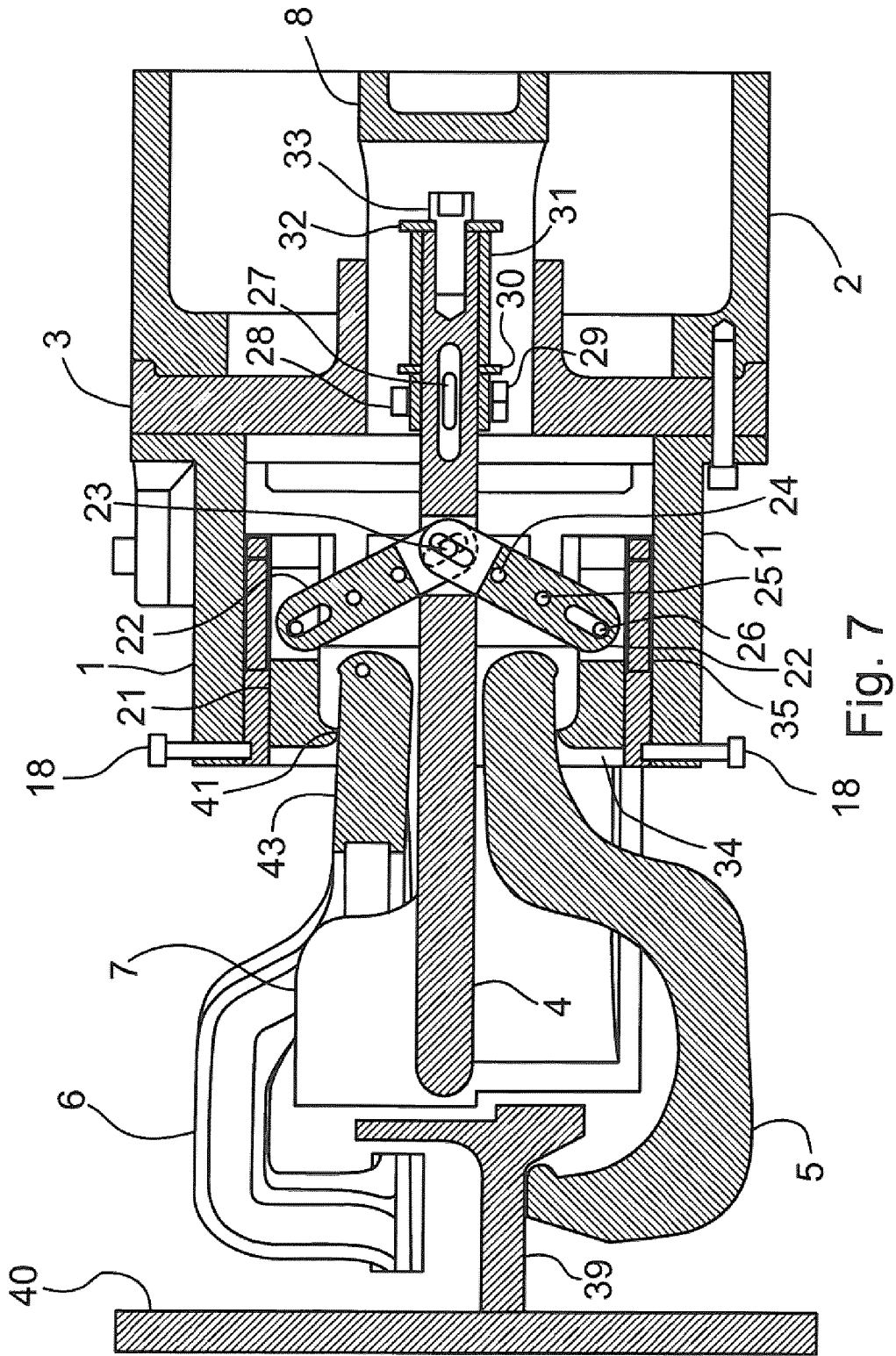

Fig. 6



18 Fig. 7

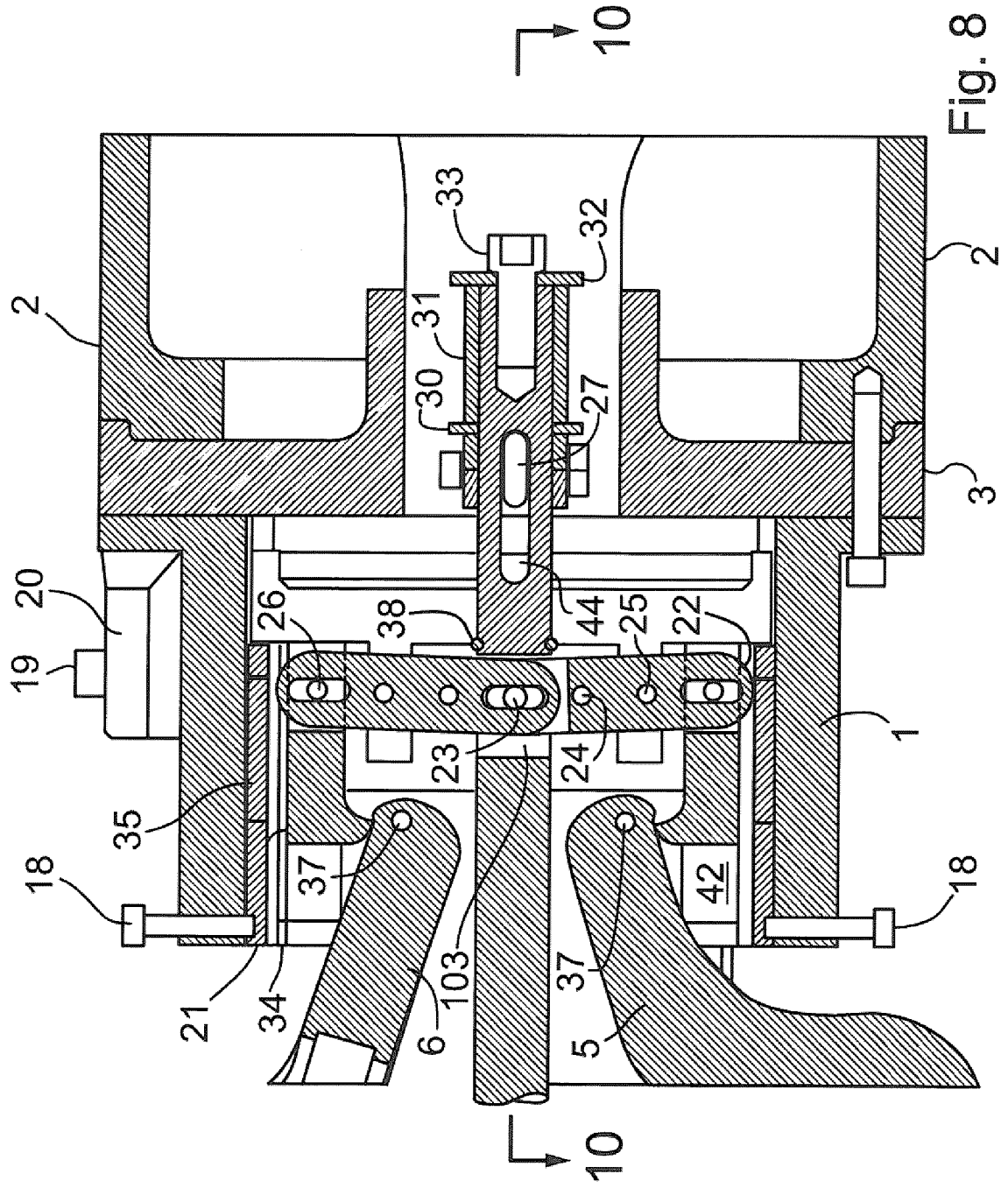

Fig. 8

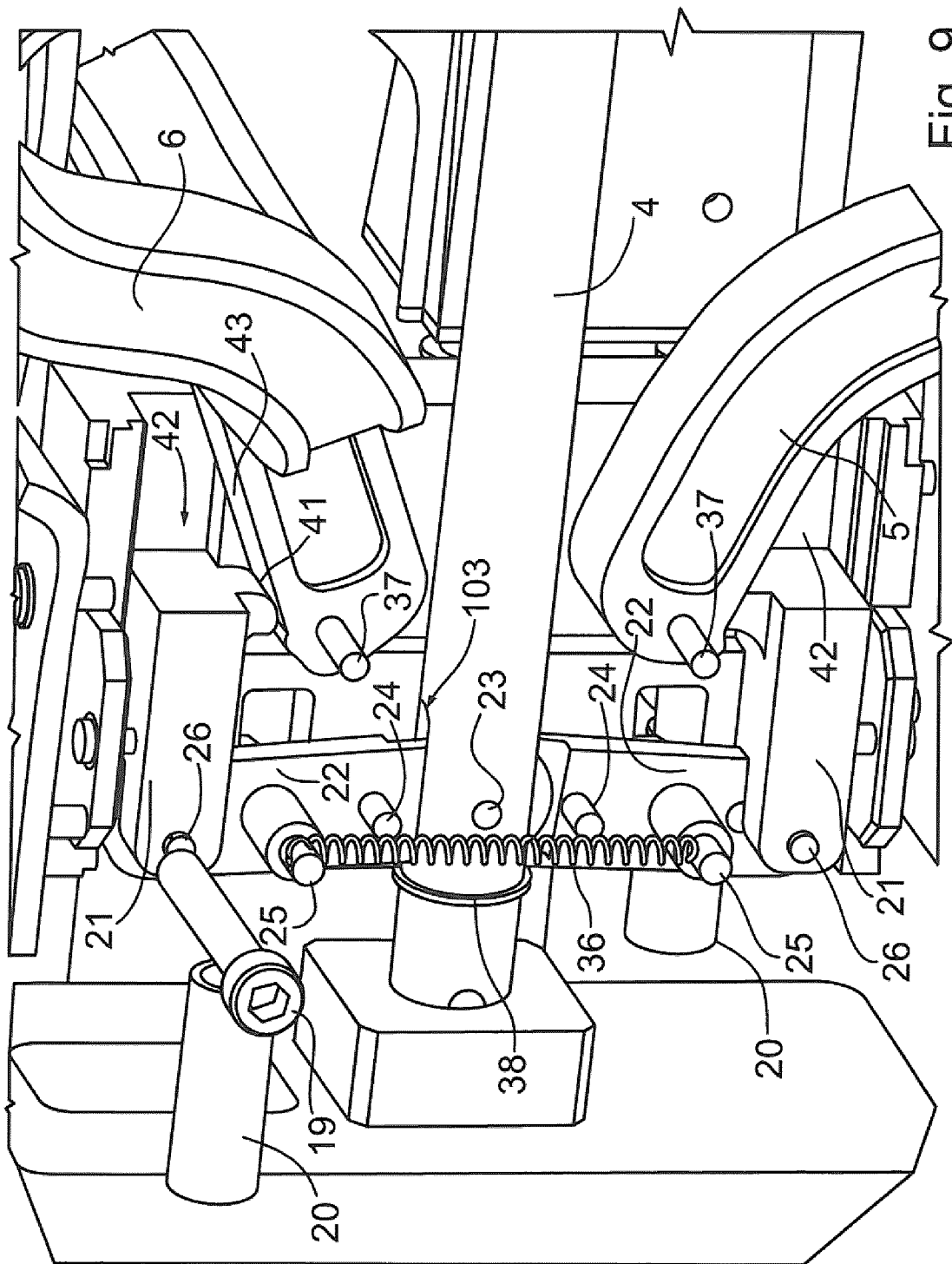

Fig. 9

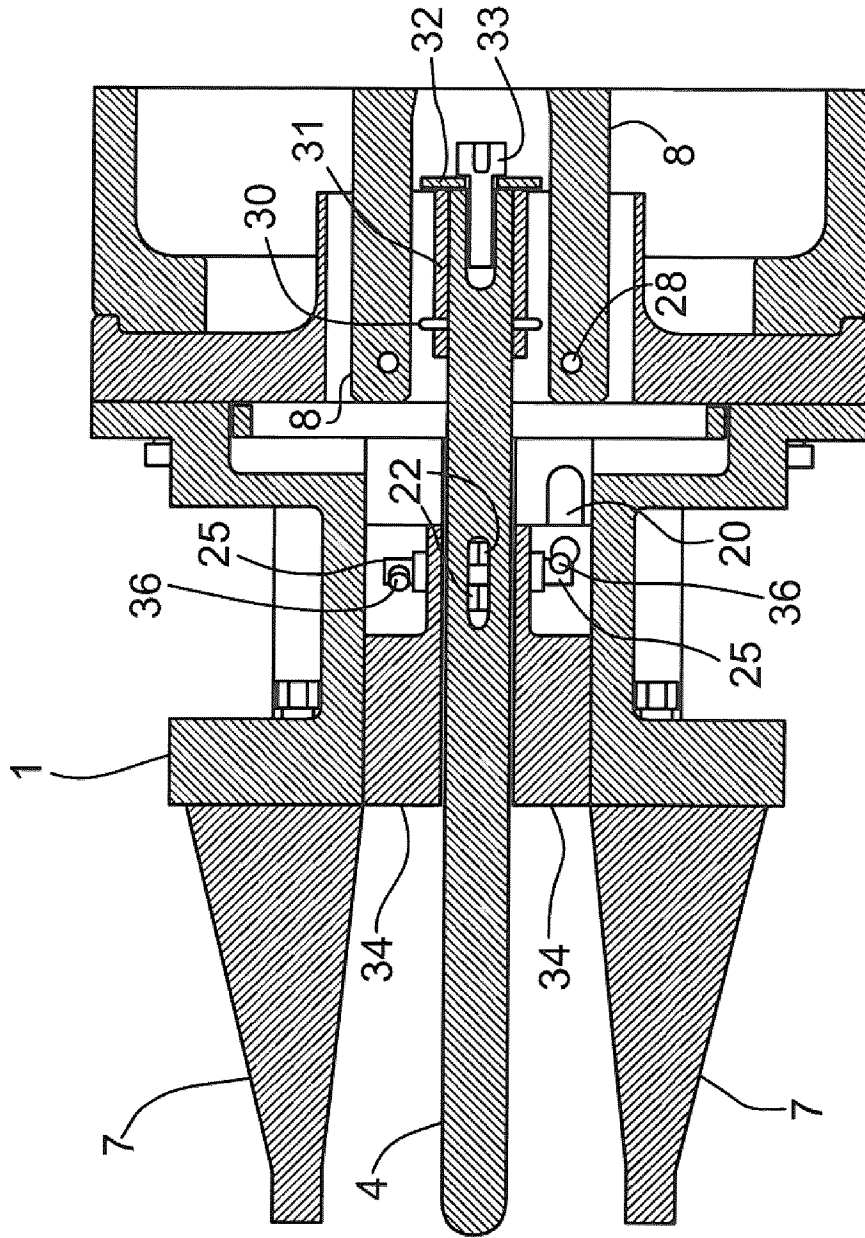

Fig. 10

12/15

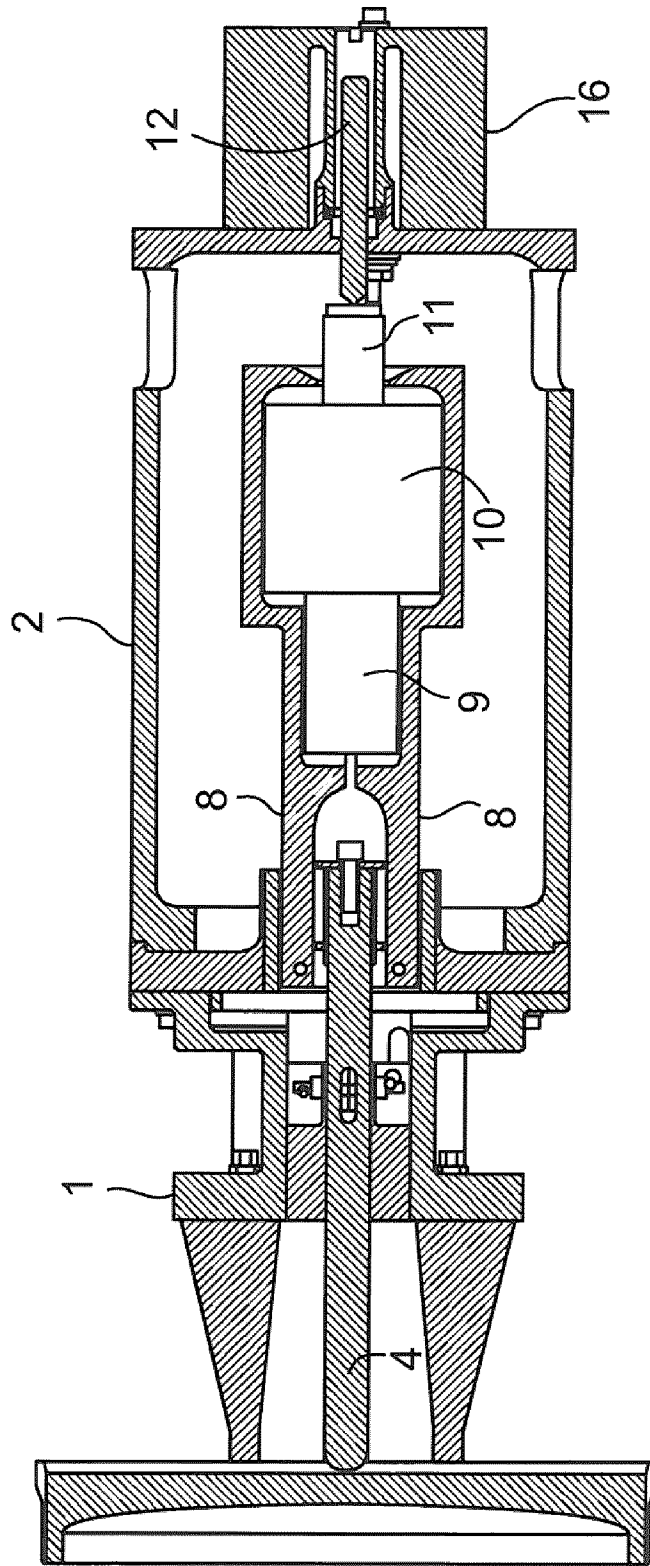

Fig. 11



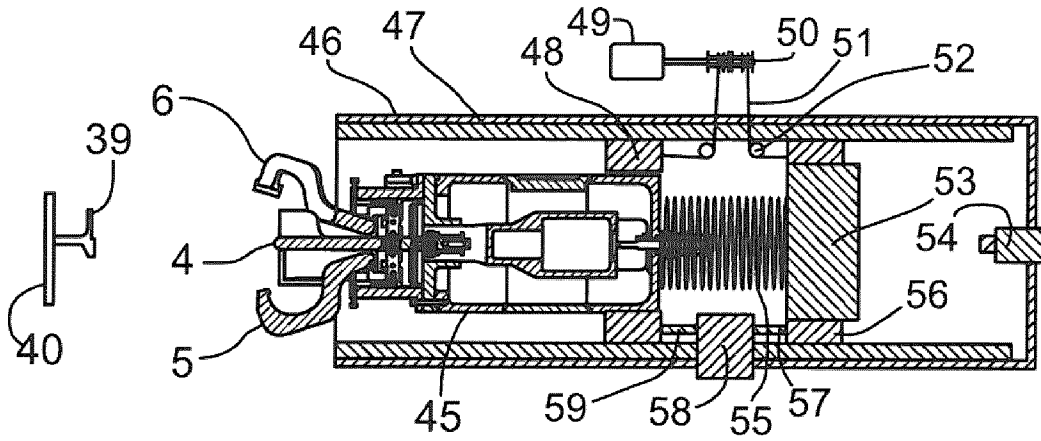

Fig 12

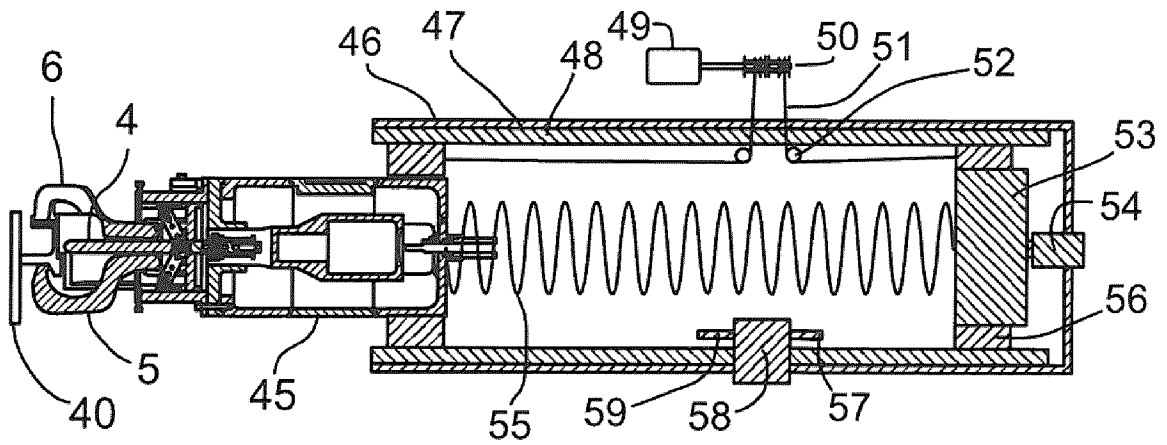

Fig 13

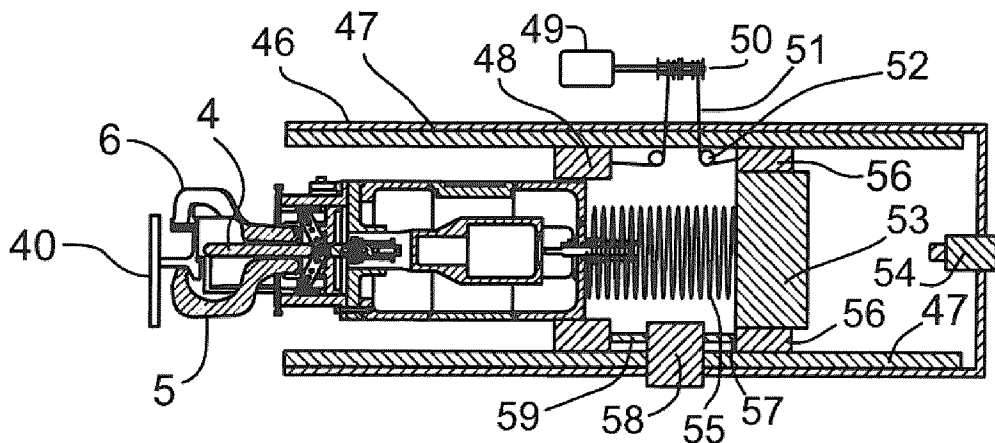

Fig 14

14/15

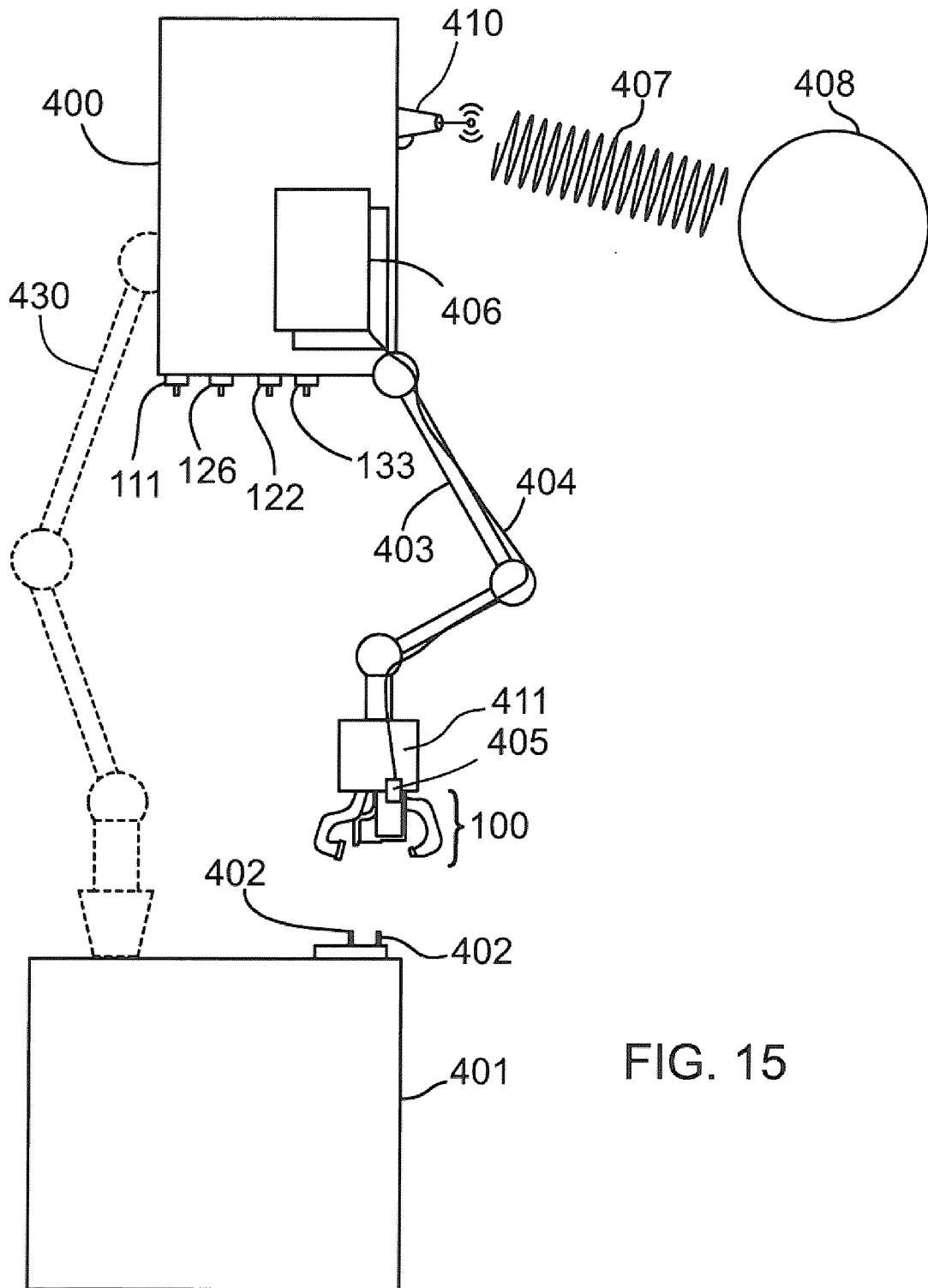

FIG. 15

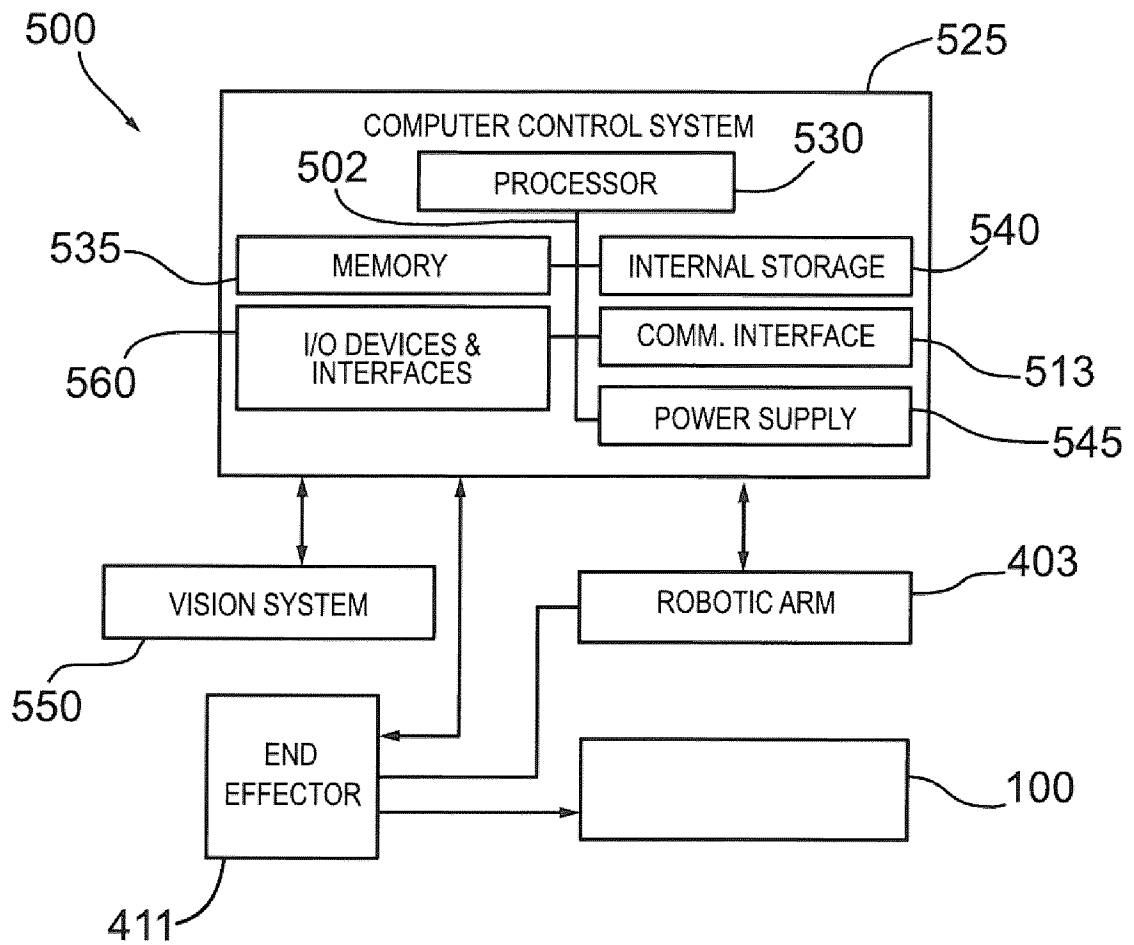

FIG. 16

## INTERNATIONAL SEARCH REPORT

International application No.  
PCT/CA2013/050227

A. CLASSIFICATION OF SUBJECT MATTER IPC: <b>B64G 1/64</b> (2006.01) , <b>B25J 11/00</b> (2006.01) , <b>B25J 15/08</b> (2006.01) , <b>B64D 1/00</b> (2006.01) According to International Patent Classification (IPC) or to both national classification and IPC		
B. FIELDS SEARCHED		
Minimum documentation searched (classification system followed by classification symbols) <b>B64G 1/64</b> (2006.01) , <b>B25J 11/00</b> (2006.01) , <b>B25J 15/08</b> (2006.01) , <b>B64D 1/00</b> (2006.01)		
Documentation searched other than minimum documentation to the extent that such documents are included in the fields searched		
Electronic database(s) consulted during the international search (name of database(s) and, where practicable, search terms used) Epoque: EPODOC, English Full-text databases.		
C. DOCUMENTS CONSIDERED TO BE RELEVANT		
Category*	Citation of document, with indication, where appropriate, of the relevant passages	Relevant to claim No.
A	US2009173832A1 (HAYS et al.) 09 July 2009 (09-07-2009) *the whole document*	1 to 16
A	JPH04151400A (MASUTANI) 25 May 1992 (25-05-1992) *the whole document*	1 to 16
A	US5735626A (KHATIBLOU et al.) 07 April 1998 (07-04-1998) *the whole document*	1 to 16
A	US4219171A (RUDMANN) 26 August 1980 (26-08-1980) *the whole document*	1 to 16
A	US4718709A (MYERS et al.) 12 January 1988 (12-01-1988) *the whole document*	1 to 16
<input type="checkbox"/> Further documents are listed in the continuation of Box C. <input checked="" type="checkbox"/> See patent family annex.		
* Special categories of cited documents :	"T"	later document published after the international filing date or priority date and not in conflict with the application but cited to understand the principle or theory underlying the invention
"A" document defining the general state of the art which is not considered to be of particular relevance	"X"	document of particular relevance; the claimed invention cannot be considered novel or cannot be considered to involve an inventive step when the document is taken alone
"E" earlier application or patent but published on or after the international filing date	"Y"	document of particular relevance; the claimed invention cannot be considered to involve an inventive step when the document is combined with one or more other such documents, such combination being obvious to a person skilled in the art
"L" document which may throw doubts on priority claim(s) or which is cited to establish the publication date of another citation or other special reason (as specified)	"&"	document member of the same patent family
"O" document referring to an oral disclosure, use, exhibition or other means		
"P" document published prior to the international filing date but later than the priority date claimed		
Date of the actual completion of the international search 19 June 2013 (19-06-2013)	Date of mailing of the international search report 25 July 2013 (25-07-2013)	
Name and mailing address of the ISA/CA Canadian Intellectual Property Office Place du Portage I, C114 - 1st Floor, Box PCT 50 Victoria Street Gatineau, Quebec K1A 0C9 Facsimile No.: 001-819-953-2476	Authorized officer  Kristian Ewen (819) 934-4269	

**INTERNATIONAL SEARCH REPORT**  
Information on patent family members

International application No.  
**PCT/CA2013/050227**

Patent Document Cited in Search Report	Publication Date	Patent Family Member(s)	Publication Date
US2009173832A1	09 July 2009 (09-07-2009)	US2009173833A1 US7828249B2 US7861974B2 US2011008102A1 US8056864B2 US2011004717A1 US8240613B2 US2009146011A1 US8245370B2 US2012291241A1 US8333347B2 US2005263649A1	09 July 2009 (09-07-2009) 09 November 2010 (09-11-2010) 04 January 2011 (04-01-2011) 13 January 2011 (13-01-2011) 15 November 2011 (15-11-2011) 06 January 2011 (06-01-2011) 14 August 2012 (14-08-2012) 11 June 2009 (11-06-2009) 21 August 2012 (21-08-2012) 22 November 2012 (22-11-2012) 18 December 2012 (18-12-2012) 01 December 2005 (01-12-2005)
JPH04151400A	25 May 1992 (25-05-1992)	None	
US5735626A	07 April 1998 (07-04-1998)	None	
US4219171A	26 August 1980 (26-08-1980)	None	
US4718709A	12 January 1988 (12-01-1988)	None	