

(19) World Intellectual Property Organization
International Bureau



(43) International Publication Date
12 September 2008 (12.09.2008)

PCT

(10) International Publication Number
WO 2008/109298 A2

(51) International Patent Classification:
A61N 1/05 (2006.01)

(74) Agent: SCHOW, Jeffrey; 730 Florida Street #2, San Francisco, CA 94110 (US).

(21) International Application Number:
PCT/US2008/055025

(81) Designated States (unless otherwise indicated, for every kind of national protection available): AE, AG, AL, AM, AO, AT, AU, AZ, BA, BB, BG, BH, BR, BW, BY, BZ, CA, CH, CN, CO, CR, CU, CZ, DE, DK, DM, DO, DZ, EC, EE, EG, ES, FI, GB, GD, GE, GH, GM, GT, HN, HR, HU, ID, IL, IN, IS, JP, KE, KG, KM, KN, KP, KR, KZ, LA, LC, LK, LR, LS, LT, LU, LY, MA, MD, ME, MG, MK, MN, MW, MX, MY, MZ, NA, NG, NI, NO, NZ, OM, PG, PH, PL, PT, RO, RS, RU, SC, SD, SE, SG, SK, SL, SM, SV, SY, TJ, TM, TN, TR, TT, TZ, UA, UG, US, UZ, VC, VN, ZA, ZM, ZW.

(22) International Filing Date:
26 February 2008 (26.02.2008)

(25) Filing Language: English

(26) Publication Language: English

(30) Priority Data:
60/891,641 26 February 2007 (26.02.2007) US
11/932,903 31 October 2007 (31.10.2007) US

(71) Applicant (for all designated States except US): NEURONEXUS TECHNOLOGIES, INC. [US/US]; 3985 Research Park Drive, Ann Arbor, MI 48108 (US).

(84) Designated States (unless otherwise indicated, for every kind of regional protection available): ARIPO (BW, GH, GM, KE, LS, MW, MZ, NA, SD, SL, SZ, TZ, UG, ZM, ZW), Eurasian (AM, AZ, BY, KG, KZ, MD, RU, TJ, TM), European (AT, BE, BG, CH, CY, CZ, DE, DK, EE, ES, FI, FR, GB, GR, HR, HU, IE, IS, IT, LT, LU, LV, MC, MT, NL, NO, PL, PT, RO, SE, SI, SK, TR), OAPI (BF, BJ, CF, CG, CI, CM, GA, GN, GQ, GW, ML, MR, NE, SN, TD, TG).

(72) Inventors; and

(75) Inventors/Applicants (for US only): VETTER, Rio [US/US]; 7371 Copper Creek Dr., Ypsilanti, MI 48107 (US). KIPKE, Daryl [US/US]; 5041 Dexter Pinckney Rd, Dexter, MI 49130 (US). PELLINEN, David [US/US]; 739 Kuehnle, Ann Arbor, MI 48103 (US). ANDERSON, David [US/US]; 2955 Lakehurst Ct, Ann Arbor, MI 48105 (US). HETKE, Jamille, Farraye [US/US]; 10724 Hewitt Rd, Brooklyn, MI 49230 (US).

Published:
— without international search report and to be republished upon receipt of that report

(54) Title: NEURAL INTERFACE SYSTEM

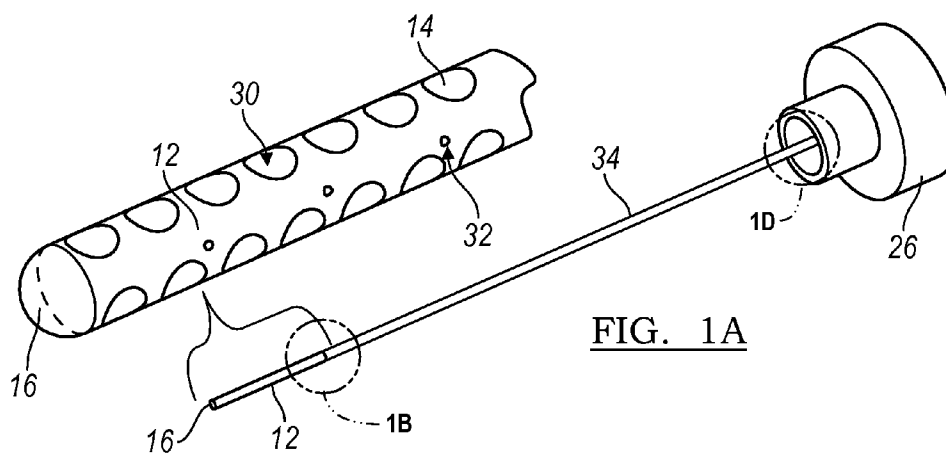

FIG. 1A

(57) Abstract: The neural interface system of the preferred embodiments includes an electrode array having a plurality of electrode sites and a carrier that supports the electrode array. The electrode array is coupled to the carrier such that the electrode sites are arranged both circumferentially around the carrier and axially along the carrier. A group of the electrode sites may be simultaneously activated to create an activation pattern. The system of the preferred embodiment is preferably designed for deep brain stimulation, and, more specifically, for deep brain stimulation with fine electrode site positioning, selectivity, tunability, and precise activation patterning. The system of the preferred embodiments, however, may be alternatively used in any suitable environment (such as the spinal cord, peripheral nerve, muscle, or any other suitable anatomical location) and for any suitable reason.

WO 2008/109298 A2

NEURAL INTERFACE SYSTEM

TECHNICAL FIELD

[0001] This invention relates generally to the neural interface field, and more specifically to an improved neural interface system having an electrode array with a series of electrode sites.

BACKGROUND

[0002] Chronic Deep Brain Stimulation (DBS) devices – ‘brain pacemakers’ – have emerged in the last decade as a revolutionary new approach to the treatment of neurological and psychiatric disorders. Conventional DBS therapy involves controllable electrical stimulation through a lead having four relatively large electrodes that are implanted in the targeted region of the brain. While conventional DBS therapy is generally safe and effective for reducing cardinal symptoms of the approved diseases, it often has significant behavioral and cognitive side effects and limits on performance. Additionally, the therapeutic effect is highly a function of electrode position with respect to the targeted volume of tissue, and more specifically, a function of which neuronal structures are influenced by the charge being delivered. With conventional electrodes, there are limitations as to how the charge is delivered and stimulation fields are limited as all of the electrode sites involved with stimulation are positioned along a single axis. Thus, there is a need for an improved neural interface system to provide fine electrode positioning, selectivity, precise stimulation patterning, and precise lead location. This invention provides such an improved and useful neural interface system.

BRIEF DESCRIPTION OF THE FIGURES

[0003] FIGURE 1 is a schematic drawing of the neural interface system of a preferred embodiment.

[0004] FIGURE 2 is a schematic drawing of the series of electrode arrays and guiding elements.

[0005] FIGURES 3A and 3B are schematic drawings of a first group of electrode sites and a first activation pattern and a second group of electrode sites and a second activation pattern respectively.

[0006] FIGURES 4A and 4B are schematic drawings of activation patterns and activation intensities.

[0007] FIGURES 5A and 5B are schematic drawings of an activation pattern along the carrier and an activation around the carrier respectively.

[0008] FIGURE 6 is a schematic drawing of excitation volumes along three different dimensions of tissue.

[0009] FIGURE 7 is a cross-sectional drawing of the silicone element, the carrier, and the electrode array.

[0010] FIGURE 8 is a photograph of ball bonds.

[0011] FIGURE 9 is a photograph of the electrode array, the plurality of electrode sites, and the carrier.

[0012] FIGURE 10 is a schematic drawing of the neural interface system implanted in a patient.

DESCRIPTION OF THE PREFERRED EMBODIMENTS

[0013] The following description of preferred embodiments of the invention is not intended to limit the invention to these embodiments, but rather to enable any person skilled in the art to make and use this invention.

[0014] As shown in FIGURE 1, the neural interface system 10 of the preferred embodiments includes an electrode array 12 having a plurality of electrode sites 14. The electrode sites may be individually activated or simultaneously activated as a group to create an activation pattern. In alternative preferred embodiments, the neural interface may further include a carrier 16 that supports the electrode array. The electrode array 12 is coupled to the carrier 16 such that the plurality of electrode sites 14 are arranged both circumferentially around the carrier 16 and axially along the carrier 16. The system 10 of the preferred embodiment is preferably designed for deep brain stimulation, and, more specifically, for deep brain stimulation with fine electrode site positioning, selectivity, tunability, and precise activation patterning. The system 10 of the preferred embodiments, however, may be alternatively used in any suitable environment (such as the spinal cord, peripheral nerve, muscle, or any other suitable anatomical location) and for any suitable reason.

1. The Electrode Array

[0015] The electrode array 12 of the preferred embodiments functions to interface with the tissue, or any other suitable substance, that it has been implanted in or coupled to. The electrode array 12 includes a plurality of electrode sites 14 such that a group of the electrode sites 14 may be simultaneously activated to create an activation pattern. The electrode array 12 provides the capability of incorporating feedback control through neural recordings for eventual on-demand stimulation. The

electrode array 12 may further include fluidic channels providing the capability to deliver therapeutic drugs, drugs to inhibit biologic response to the implant, or any other suitable fluid.

[0016] The electrode array 12 is preferably one of several variations. In a first variation, the electrode array 12 is a planar array. In this variation, the electrode array 12 would be particularly useful for stimulation of surface tissue such as surface stimulation of the brain or spinal cord. In a second variation, the electrode array 12 has a three dimensional geometry. The geometry preferably has a circular or semi-circular cross section, but may alternatively be any suitable geometry with any suitable cross section such as a v-shaped cross section. The planar electrode array 12 is preferably pre-formed into the three dimensional geometry. This is preferably completed by positioning the planar electrode array 12 in a mold and then placing the mold and electrode array 12 in a furnace to be tempered, but may alternatively be completed by any suitable process that alters the physical shape of the planar substrate. The electrode array 12 in this variation, may be wrapped directly around the tissue to be stimulated such as a peripheral nerve or spinal cord. The electrode array 12 of the second variation may be coupled to the carrier 16. The electrode array 12 is preferably coupled to the carrier 16 such that the plurality of electrode sites 14 are arranged both circumferentially around the carrier 16 and axially along the carrier 16. Although the electrode array 12 is preferably one of these variations, the electrode array 12 may be in any suitable configuration to interface with the tissue, or any other suitable substance, that it has been implanted in or coupled to.

[0017] The neural interface system 10 may include a single electrode array 12 with a plurality of electrode sites 14 or may alternatively include a series of electrode arrays 12, each with a plurality of electrode sites 14. The neural interface system 10

may further include a guiding element that positions the series of electrode arrays 12 in a three dimensional arrangement, or the electrode arrays 12 may alternatively be arranged in a three dimensional manner without an additional guiding element. The neural interface system 10 may include one guiding element for every electrode array 12, such that the ratio of guiding elements to electrode arrays 12 is 1:1. Alternatively, the neural interface system 10 may include one guiding element for every two or more electrode arrays 12, such that the ratio of guiding elements to first electrode arrays 12 is less than 1:1. Additionally, the guiding elements may be coupled to a chamber 26, as shown in FIGURE 2, or any other suitable element of the neural interface system 10 and may include a sharpened end adapted to penetrate the tissue and aid in the insertion of the electrical subsystems and/or guiding elements into the tissue.

[0018] As shown in FIGURE 2, the guiding element is preferably a rigid guiding element 28. The guiding element may be a stylet, a guide tube, a connector 34, or any other suitable guiding element. In this variation, the rigid guiding element 28 guides the electrode arrays 12 into a three-dimensional arrangement along predetermined trajectories. The rigid guiding elements 28 preferably implant the electrode arrays into a specific location and a specific three-dimensional spatial distance from one another determined by the location of the guiding elements 28. For example, as shown in FIGURE 2, the guiding elements 28 are positioned at a specific location and a specific three-dimensional spatial distance from one another prior to implantation. Upon insertion of the rigid guiding elements 28 and the series of electrode arrays 12 the guiding elements 28 will move the electrode arrays 12 along the predetermined trajectory into the corresponding specific location and three-dimensional spatial distance from one another as the guiding elements 28. The

trajectories are preferably parallel, but may alternatively be at any suitable angle to one another to implant the series of electrode arrays 12 into a three-dimensional arrangement. The material of the rigid guiding element 28 is preferably a generally rigid material such as metal or plastic, but may alternatively be made from any suitable material.

2. The Plurality of Electrode Sites

[0019] The plurality of electrode sites 14 of the preferred embodiments functions to electrically communicate with the tissue, or any other suitable substance, that it has been implanted in or coupled to. The electrical communication is preferably a high-frequency, pulsed electric current; electrical stimulation in monopolar, bipolar, tripolar, and/or quadrapolar modes; a recording of electrical signals; data transmission; and/or any other suitable electrical communication.

[0020] The plurality of electrode sites 14 can be activated individually or in selectable groups of electrode sites. The simultaneous activation of a group of electrode sites 14 creates an activation pattern, generates an electric field in the tissue medium having a spatial distribution of current density, and influences the pattern of neural excitation. This will provide dynamic tunable electrical stimulation ranging from macroscale activation, as shown in FIGURE 3A and 4A, to more selective directional activation patterning using smaller groups of sites along or around the carrier, as shown in FIGURE 3B and 4B. Additionally, each of the electrode sites 14 may be activated with an independent activation intensity. As shown in FIGURES 4A and 4B each activation intensity may be individually distinct, or groups of electrode sites may each have the same activation intensity.

[0021] As shown in FIGURES 5A and 5B, activation patterns from an electrode array 12 can be translated not only axially up and down a carrier 16 (FIGURE 5A), but also side-to-side or circumferentially around the carrier 16 (FIGURE 5B) thus allowing for slight corrections in the position of the electrode by electrical means. As shown in FIGURES 5A and 5B, the activation patterns 36 and 38 (shown as isopotential contours) are each created by the activation of two electrode sites 14. Noting that curvature and direction of curvature of isopotential surfaces indicate magnitude and direction of second spatial derivative, the preferred direction of excitation can be adjusted by the choice of sites activated in an array. An activation pattern generates excitation volumes that are specific for neural fibers or axons traveling in the three principle directions of the electrode array 12. As shown in FIGURE 6, the excitation volumes 40, 42, and 44 are generated by an activation pattern, specifically the activation pattern shown in FIGURE 5A. The first excitation volume 40 is for axon orientation perpendicular to the electrode and above it, the second excitation volume 42 is for vertically traveling axons, and the third excitation volume 44 is for axons traveling parallel to the electrode.

[0022] As shown in FIGURES 3A and 3B, a group of the electrode sites are simultaneously activated to create an activation pattern. As shown in FIGURE 3A, activating a first group of electrode sites 18 creates a first activation pattern 20. The first group of electrode sites 18 includes each of the electrode sites around the circumference of the carrier 16 at a particular axial location. As shown in FIGURE 3B, activating a second group of electrode sites 22 creates a second activation pattern 24. The second group of electrode sites 22 includes electrode sites at multiple axial locations and less than each of the electrode sites around the circumference of the carrier at a particular axial location.

[0023] The excitation of tissue surrounding an electrode site 14 is determined by electrochemical properties of the individual electrode site and by geometric properties of the entire electrode array and carrier assembly. For an electrode array 12 with several electrode sites 14 activated simultaneously, the activation pattern, and therefore the current flow surrounding the electrode, is complex resulting in an equally complex pattern of tissue excitation. At a basic level, the spreading resistance of an electrode site may determine the ability of the site to deliver charge to excitable tissue. When several electrode sites 14 on an electrode array 12 are activated simultaneously there is an interaction of the electrode sites and activation patterns. For example, the second activation pattern, as shown in FIGURE 3, may be modulated with the activation of a third distinct group of electrode sites 14. Furthermore, multiple groups of activated electrode sites can be overlapping or non-overlapping.

[0024] In one specific variation of the electrode array 12, as shown in FIGURE 1, the electrode array 12 preferably includes sixty-four stimulation electrode sites 30 and thirty-two recording electrode sites 32 positioned circumferentially around and axially along the carrier 16. Each stimulation electrode site 30 has a surface area of preferably 0.196 mm^2 (diameter = $500 \text{ }\mu\text{m}$), but may alternatively have any suitable surface area. Each recording electrode site 32 has a surface area of preferably 0.00196 mm^2 (diameter = $50 \text{ }\mu\text{m}$), but may alternatively have any suitable surface area. The stimulation electrode sites 30 are preferably positioned such that four sites will be equally spaced around the circumference of the carrier 16 (center-to-center spacing is about equal to $750 \text{ }\mu\text{m}$). Sites will also be preferably spaced at $750 \text{ }\mu\text{m}$ in the axial direction (center-to-center) and positioned at sixteen successive locations. Between each row of stimulation electrode sites 30, two recording electrode sites 32

will preferably be positioned on opposite sides of the carrier 16. The positions of each recording electrode site pair will preferably shift ninety degrees between successive depths. Alternatively, there may be any suitable number of stimulation electrode sites 30 and recording electrode sites 32, and the stimulation electrode sites 30 and recording electrode sites 32 may alternatively be positioned in any other suitable arrangement.

3 Fabrication of The Electrode Array and The Plurality of Electrode Sites

[0025] The electrode array 12 is preferably made from a thin-film polymer substrate (or any other suitable material) such that there is high density of electrode sites 14 at a first end of the array (the distal end) and bonding regions at a second end of the array (the proximal end). The proximal end is preferably thicker than the distal end of the electrode array 12 to accommodate the bonding regions or the integration of a second electrical subsystem. The polymer substrate is preferably parylene or some combination of parylene and inorganic dielectrics, but may alternatively be made out of any suitable material. The distal end of the array is preferably coupled to a carrier 16 to provide structural support. Additionally, the distal end will be in direct contact with the tissue and so will preferably be made from suitable materials for both biocompatibility and dielectrics.

[0026] In general, the fabrication techniques for the electrode array 12 are preferably similar to those used to create integrated circuits and therefore preferably utilize similar substrate, conductor and insulating materials. Fabrication of the electrode array 12 preferably starts on a wafer substrate and the electrode sites 14 and additional features are preferably added using a number of photolithographically patterned thin-film layers that are preferably defined by etching. The electrode

arrays 12 produced in this manner are preferably reproducible, batch-processed devices that have features preferably defined to within less than +/- 1 μm . In addition, many of the fabrication techniques are preferably compatible with the inclusion of an integrated flexible ribbon cable or connector 34 and a second electrical subsystem such as on-chip circuitry for signal conditioning and/or stimulus generation.

[0027] Polymer electrode arrays preferably include metal traces sandwiched between upper and lower layers of insulating polymer. One such polymer is parylene (parylene-C, Specialty Coating Systems, Indianapolis, IN, USA). The polymer is vapor phase deposited onto an oxidized silicon wafer that acts as a carrier. A layer of photoresist is then spun on and patterned in preparation for metal lift-off. Layers of titanium and platinum are preferably next deposited and patterned using lift-off. The top layer of polymer is then vapor phase deposited. The wafers are then preferably patterned and dry-etched to form the final electrode shape and create openings to the underlying metal. These metal surfaces form the electrode sites and additional features such as conductive interconnects and bond pads. HF dissolution of the oxide release layer is used to remove the devices from the wafer. The devices are finally cleaned using multiple soaks and rinses in DI water. Presently, the process requires only two photolithographic masks resulting in rapid turn-around for easy design iteration.

[0028] The electrode sites 14 are preferably patterned directly onto the polymer substrate. The electrode sites 14 are preferably metal such as iridium, platinum, gold, but may alternatively be any other suitable material. Iridium oxide is preferably used for the electrode sites 14 due to its high charge capacity (3 mC/cm^2). The targeted charge injection limit for the activation pattern 46 as shown in FIGURE

4A is preferably 500 nC/cm², while preferably maintaining a safe charge density of 30 μC/cm². The targeted composite impedance (electrode contact plus lead) is preferably 10 kΩ (stimulating contacts) and 100 kΩ (recording contacts). Impedance matching will preferably occur across all sites. Each site will preferably be electrically isolated with cross-talk preferably below 1%.

[0029] The electrode array 12 preferably further includes conductive interconnects disposed between layers of dielectrics that insulate the interconnects on top and bottom sides. Preferably a group of the conductive interconnects terminate with electrode sites 14 on the distal end and/or with bond pads for electrical connection to external instrumentation and/or hybrid chips on the proximal end. The conductive interconnects are preferably metal or polysilicon, but may alternatively be any other suitable material. Polyimide, parylene, inorganic dielectrics, or a composite stack of silicon dioxide and silicon nitride is preferably used for the dielectrics, however any other suitable materials may alternatively be used.

[0030] The conductive interconnects are preferably made as wide as possible to reduce the resistance. The conductive interconnects will vary in length as they terminate at different locations, and so in order to equalize the resistance across all leads, the line widths are preferably adjusted accordingly. These conductive interconnects, as well as the connections will be preferably buried in silicone and thus not be at risk to leakage, as shown in FIGURE 1D. The electrode array 12 will function more efficiently if all the impedances of the conductive interconnects are equal as seen from the bonding area. This is preferably accomplished by increasing the width of the longer traces. Preferably, the width of each segment of each conductive interconnect is optimized using a “hill climbing” method. A layout

program preferably generates polygons representing the several conductive interconnects.

4. The Carrier

[0031] The carrier 16 of the preferred embodiments, as shown in FIGURE 9, functions to support the electrode array 12. The carrier 16 may further function to shuttle the electrode array 12 into tissue or other substances. The shape of the carrier 16 is preferably tubular with about a 1-mm diameter, but may alternatively be any suitable shape of any suitable diameter for the desired functions. The carrier 16 may include a sharpened end adapted to penetrate the tissue and aid in the insertion of the carrier 16 and the electrode array 12 into the tissue. The carrier 16 may further extend the functionality of the system by providing fluidic channels through which therapeutic drugs, drugs to inhibit biologic response to the implant, or any other suitable fluid may be transmitted. This provides for the precise delivery of specific pharmaceutical compounds to localized regions of the body, such as the nervous system, and could facilitate, for example, intraoperative mapping procedures or long-term therapeutic implant devices. The fluidic channels may also provide a location through which a stiffener or stylet may be inserted to aid with implantation. Alternatively, the carrier 16 may further include a separate lumen through which the stiffener or stylet may be inserted.

[0032] The carrier 16 is preferably one of several variations. In a first variation, the carrier 16 is a polymeric carrier 16. The carrier 16 is preferably made of a polymer such as polyimide or silicone, but may be alternatively made from any other suitable material. The carrier 16 is preferably flexible, but may alternatively be rigid or semi rigid. In a second variation, the carrier 16 is a metal carrier. The carrier in this

variation may be a solid metal tube or cylinder, or it may alternatively be perforated or not solid in any other suitable fashion. In a third variation, the carrier 16 is resorbable carrier 16, which is resorbed into tissue after a period of time, and upon resorption, the electrode array 12 will be left to float freely in the brain or other suitable tissue or material. The resorbable carrier 16 is preferably made of implantable medical fabric woven or knitted from a bioresorbable polymer. The bioresorbable polymer is preferably polyglycolide or polylactide, but may alternatively be made from any suitable bioresorbable material. Although the carrier 16 is preferably one of these three variations, the carrier 16 may be any suitable element to shuttle the electrode array 12 and the connector 34 into tissue or other substances and provide structural support.

5. The Second Electrical Subsystem and the Connector

[0033] Additionally, the system 10 may further include a second electrical subsystem. The second electrical subsystem of the preferred embodiments functions to operate with the electrode array 12. The second electrical subsystem may include multiple different electrical subsystems or a series of the same subsystems. The second electrical subsystem may be integrated into the proximal end of the electrode array 12 or may be coupled to the electrode array 12 via a connector 34 as described below. The second electrical subsystem is preferably at least one of several variations of suitable electronic subsystems to operate with the electrode array 12 or any combination thereof. The second electrical subsystem may be a printed circuit board with or without on-board integrated circuits and/or on-chip circuitry for signal conditioning and/or stimulus generation, an Application Specific Integrated Circuit (ASIC), a multiplexer chip, a buffer amplifier, an electronics interface, an

implantable pulse generator (produces a high-frequency, pulsed electric current), an implantable rechargeable battery, integrated electronics for either real-time signal processing of the input (recorded) or output (stimulation) signals, integrated electronics for control of the fluidic components, any other suitable electrical subsystem, or any combination thereof. In one specific variation, as shown in FIGURE 10, the neural interface system 10 includes an electrode array 12, an electronics interface 56 and implantable pulse generator located in a cranial burr-hole chamber, and an implantable rechargeable battery 58. Although the second electrical subsystem is preferably one of these several subsystems, the second electrical subsystem may be any suitable element or combination of elements to operate the electrode array 12.

[0034] Additionally, the system 10 may further include a connector 34. The connector 34 of the preferred embodiments functions to couple the electrode array 12 to the second electrical subsystem. The connector 34 is preferably one of several variations. As shown in FIGURE 1, the connector 34 is preferably a flexible ribbon cable. The ribbon cable is preferably polymer ribbon cable, but may alternatively be any other suitable ribbon cable. The connector 34 may alternatively be any suitable element to couple the electrode array 12 to the second electrical subsystem, such as wires, conductive interconnects, etc.

[0035] The ribbon cable may be encased in silicone or any other suitable material, as shown in FIGURES 1D and 7A. In some situations, the electrical subsystem may have multiple ribbon cables. Preferably, multiple ribbon cables would be physically attached along their entire length, using a suitable adhesive such as medical grade adhesive or any other suitable connection mechanism. The cable is preferably connected to the electrical subsystems through rivet bonds, ball bonds, or

any other suitable connection mechanisms. The connector 34 may alternatively be seamlessly manufactured with the first and or second electrical subsystem. The connector 34 may further include fluidic channels adapted to deliver therapeutic drugs, drugs to inhibit biologic response to the implant, or any other suitable fluid.

6. The Stylet and the Guide Tube

[0036] Additionally, the system 10 may further include a stylet. The stylet of the preferred embodiments functions to penetrate the tissue or other material and/or functions to provide structural support to the system during implantation. The stylet is preferably inserted into a lumen of a carrier 16, but may alternatively be located and inserted into any suitable component of the system in any suitable manner. The stylet may include a sharpened end adapted to penetrate the tissue and aid in the insertion of the stylet, the carrier 16, and/or the electrode array 12 into the tissue. The stylet is preferably removed from the tissue following the placement of the electrode array 12, but may alternatively be adapted to remain in the tissue while still allowing the implanted electrode array 12 to float freely in the brain. This may be accomplished by the stylet being selectively flexible (through electrical stimulus or other suitable method) or by being resorbable into the tissue after a period of time. The stylet is preferably made from a stiff material such as metal, but may alternatively be made from any suitable material. In one variation, the metal is preferably insulated metal wire. In this variation, the insulated metal wire may not have insulation covering a sharpened tip, and thus can be used as a conventional single-channel microelectrode.

[0037] Additionally, the system 10 may further include a guide tube. The guide tube of the preferred embodiments functions to facilitate the insertion of the

electrode array 12 and/or functions to provide structural support to the system during implantation. The guide tube may be further adapted to allow the electrode array 12 to move freely in the tissue, allowing the placement of the electrode array 12 without disconnecting the second electrical subsystem. The guide tube is preferably made of a rigid material, which can be inserted into tissue or other substances without buckling and can maintain a generally straight trajectory through the tissue. The material may be uniformly rigid, or rigid only in a particular direction (such as the axial direction). The material is preferably plastic such as a medical grade plastic, but may alternatively be any suitable material such as metal or a combination of materials. The guide tube may further include a sharpened end adapted to penetrate the tissue and aid in the insertion of the guide tube into the tissue. The guide tube may also include alignment and or fixation features to facilitate positioning and stabilizing the series of electrode array 12 in the tissue, particularly during removal of the guide tube.

7. Other Aspects of the Invention

[0038] As shown in FIGURE 1, the neural interface system 10 of the preferred embodiments includes an electrode array 12 having a plurality of electrode sites 14 and a carrier 16 that supports the electrode array. The electrode array 12 is coupled to the carrier 16 such that the plurality of electrode sites 14 are arranged both circumferentially around the carrier 16 and axially along the carrier 16. In one preferred embodiment, the electrode array 12 preferably includes both recording electrode sites 32 and stimulation electrode sites 30, as shown in FIGURE 1A. In this preferred embodiment, the electrode array 12 further includes interconnects 48 ascending from the electrode array 12, as shown in FIGURE 1B. The interconnects 48

transition from the outer surface of the carrier 16 into the core such that the connection point and the entire connector 34 are imbedded in silicone, as shown in FIGURE 1B. To facilitate adhesion between the silicone and polymer, small non-homogeneous perforations are preferably micromachined in the polymer substrate to allow for liquid silicone to flow into and form a robust anchor after being cured. The electrode array 12 is preferably connected to the connector 34 via the interconnects 48, as shown as FIGURE 1C.

[0039] The electrode array 12 and carrier 16 are preferably assembled by a method, as shown in FIGURE 7, including any of the following steps, any suitable additional steps, and any combination of steps thereof.

- Connecting electrode array 12 to the connector 34. This is preferably completed with ball bonds 52, as shown in FIGURE 8, but may alternatively include any other suitable technique. “Rivet” bonds bonding technique involves ball bonding through a hole in the polymer cable that is surrounded by an annular bond pad, to a bond pad on the device underneath. This effectively forms a rivet that connects the two devices both electrically and mechanically, as shown in FIGURE 8.
- Connecting a second electrical subsystem such as a flexible printed circuit board (PCB) to the connector 34. This is preferably completed with wire-bonds bonded to bond pads on the connector 34, but may alternatively include any other suitable technique.
- Pre-forming the electrode array 12. The planar electrode array 12 will be preferably pre-formed into a 3-dimensional cylindrical form, or any other suitable form to be compatible with the carrier 16. This step is preferably completed by positioning the planar electrode array 12 in a

mold and then placing the mold and electrode array 12 in a furnace to be tempered, but may alternatively be completed by any suitable process that alters the physical shape of the planar substrate.

- Connecting the interconnects 48. In some variations, there may be two interconnects 48 such as ribbon cables ascending from the electrode array 12, as shown in FIGURE 1B. These two interconnects 48 are preferably connected along their entire length, to form a connector 34, using a medical grade adhesive, or any other suitable connection mechanism.
- Injection molding the silicone element 50, as shown in FIGURE 7. This is preferably completed by providing an injection mold tool that provides for the placement of the connector 34 and connections within it, as shown in FIGURE 7A, and then liquid medical grade silicone will be preferably injected into the mold and thermally cured. The carrier 16 may be the distal portion of the silicone element 50, as shown in FIGURE 7B, wherein the electrode array 12 is wrapped around the carrier 16. Additionally, a tube may be embedded in the silicone and will act as a stylet passage 54. The tube is preferably made of a polymer such as PTFE or any other suitable material with a low coefficient of friction.

[0040] A method of implanting an neural interface system 10, as shown in FIGURE 10, preferably comprises any combination of the following steps (or any other suitable steps):

- attaching the chamber 26 to the skull (preferably in a cranial burr-hole) of a patient;

- implanting, through the guide tube and/or with a stylet, an electrode array 12 coupled via a connector 34 to a second electrical subsystem;
- removing the guide tube over the second electrical subsystem and/or removing the stylet;
- placing the second electrical subsystem within the chamber 26; and
- sealing the electrical subsystems within the chamber 26.

[0041] Although omitted for conciseness, the preferred embodiments include every combination and permutation of the various electrode arrays, the various carriers, the various electrical subsystems and connectors, and the various guide tubes and stylets.

[0042] As a person skilled in the art will recognize from the previous detailed description and from the figures and claims, modifications and changes can be made to the preferred embodiments of the invention without departing from the scope of this invention defined in the following claims.

CLAIMS

I claim:

1. A neural interface system, comprising:
 - an electrode array having a plurality of electrode sites that electrically communicate with their surroundings; wherein the plurality of electrode sites includes a subset of stimulation electrode sites and a subset of recording electrode sites; and
 - a carrier that supports the electrode array;
 - wherein the electrode array is coupled to the carrier such that the plurality of electrode sites are arranged both circumferentially around the carrier and axially along the carrier.

2. The neural interface system of Claim 1 further including a second electrode array having a second plurality of electrode sites that electrically communicate with their surroundings and a second carrier that supports the second electrode array.

3. The neural interface system of Claim 2 further including a guiding element that positions the electrode arrays in a three dimensional arrangement.

4. The neural interface system of Claim 1 wherein there the subset of stimulation electrode sites includes at least thirty-two stimulation electrode sites and the subset of recording electrode sites includes at least sixteen recording electrode sites.

5. The neural interface system of Claim 4 wherein the subset of stimulation electrode sites are positioned such that at least two sites are spaced around the circumference of the carrier at each axial location and such that at least eight sites are spaced along the axis of the carrier at each circumferential location, and wherein at least two recording electrode sites are located between each row of stimulation electrode sites and are positioned on opposite sides of the carrier from one another.
6. The neural interface system of Claim 1 wherein the carrier is cylindrical.
7. The neural interface system of Claim 6 wherein the carrier further includes fluidic channels adapted to transmit fluid.
8. The neural interface system of Claim 1 wherein the carrier is a flexible polymer.
9. The neural interface system of Claim 1 further including a second electrical subsystem that operates with the electrode.
10. The neural interface system of Claim 9 further including a connector that couples the electrode array to the second electrical subsystem.
11. The neural interface system of Claim 10 wherein the connector is a polymer ribbon cable.

12. The neural interface system of Claim 10 wherein the connector further includes fluidic channels adapted to transmit fluid.

13. The neural interface system of Claim 1 wherein the electrode array is made from a thin-film substrate and the plurality of electrode sites is located at a first end of the electrode array and bonding regions are located at a second end of the electrode array, wherein conductive interconnects couple the plurality of electrode sites on the first end of the electrode array to the bonding regions on the second end of the electrode array.

14. The neural interface system of Claim 13 wherein the electrode array further includes metal traces positioned between a first layer of polymer and a second layer of polymer, wherein the metal traces include the plurality of electrode sites, the bonding regions, and conductive interconnects.

15. The neural interface system of Claim 14 wherein the conductive interconnects are adapted such that the width of the conductive interconnect is proportional to the length of the conductive interconnect, such that the resistance is generally equal across all conductive interconnects.

16. A method of creating a pattern of tissue medium excitation comprising the steps of:

- providing an electrode array having a plurality of electrode sites that electrically communicate with their surroundings;
- simultaneously activating of a group of electrode sites and thereby creating an activation pattern;
- generating an electric field in the tissue medium having a spatial distribution of current density; and
- influencing the pattern of tissue medium excitation.

17. The method of Claim 16 wherein each of the electrode sites are activated with an independent activation intensity.

18. The method of Claim 17 wherein a first activation pattern is created by activating a first group of electrode sites, wherein the first group of electrode sites includes each of the electrode sites around the circumference of the carrier at a particular axial location.

19. The method of Claim 17 wherein a second activation pattern is created by activating a second group of electrode sites, wherein the second group of electrode sites includes electrode sites at multiple axial locations and less than each of the electrode sites around the circumference of the carrier at a particular axial location.

20. The neural interface system of Claim 19, wherein the second activation pattern is modulated with the activation of a third group of electrode sites.

21. A method of assembling a neural interface system comprising the steps of:
- providing a electrode array having a plurality of electrode sites that electrically communicate with their surroundings;
 - providing a connector;
 - connecting the electrode array to the connector; and
 - injection molding a silicon element having an end portion;
 - wherein the silicon element encases the connector and the end portion of the silicon element is coupled to the electrode array.
22. The method of claim 21 wherein the electrode array is a planar electrode array and the method further comprises the step of pre-forming the planar array into a 3-dimensional form.
23. The method of claim 22 wherein the step of pre-forming the planar array into a 3-dimensional form is accomplished by the steps of positioning the planar electrode array in a mold and tempering the mold and electrode array.

24. A neural interface system, comprising:
- an electrode array having a plurality of electrode sites that electrically communicate with their surroundings;
 - wherein the plurality of electrode sites includes a subset of at least thirty-two stimulation electrode sites and a subset of at least sixteen recording electrode sites; and
 - a carrier that supports the electrode array;
 - wherein the electrode array is coupled to the carrier such the subset of stimulation electrode sites are positioned such that at least two sites are spaced around the circumference of the carrier at each axial location and such that at least eight sites are spaced along the axis of the carrier at each circumferential location, and wherein at least two recording electrode sites are located between each row of stimulation electrode sites and are positioned on opposite sides of the carrier from one another.

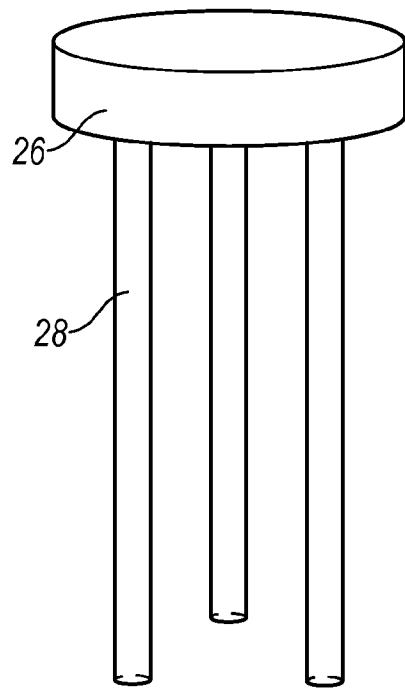
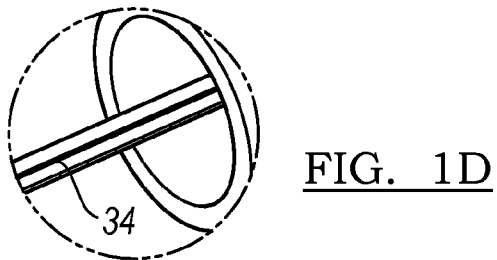
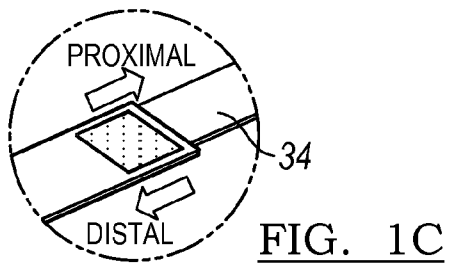
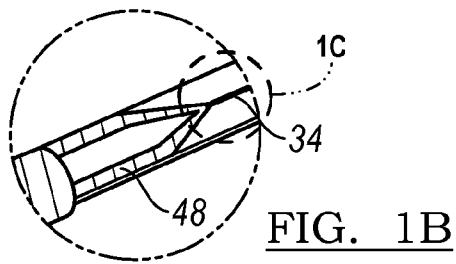
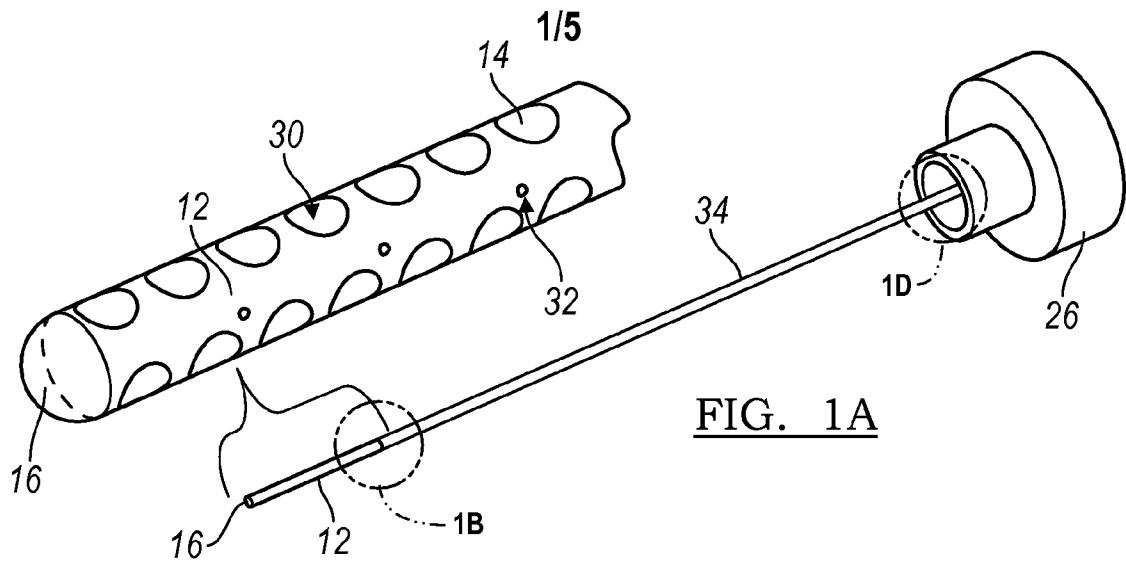

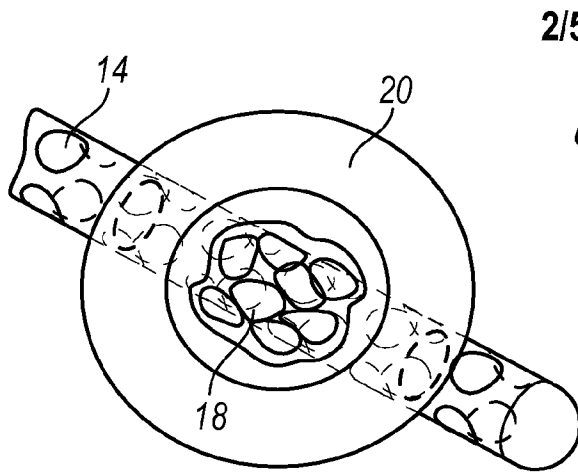

FIG. 3A

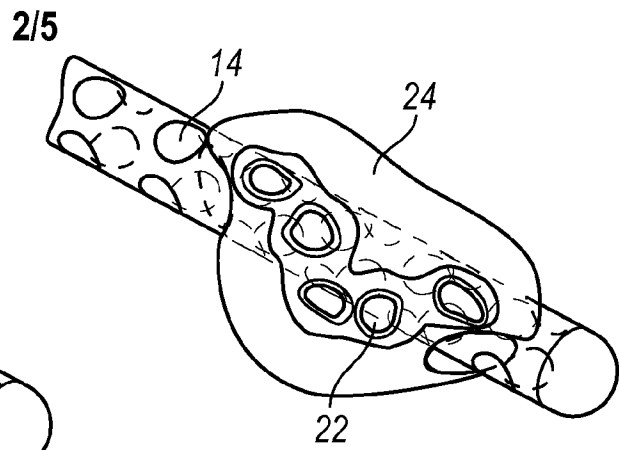

FIG. 3B

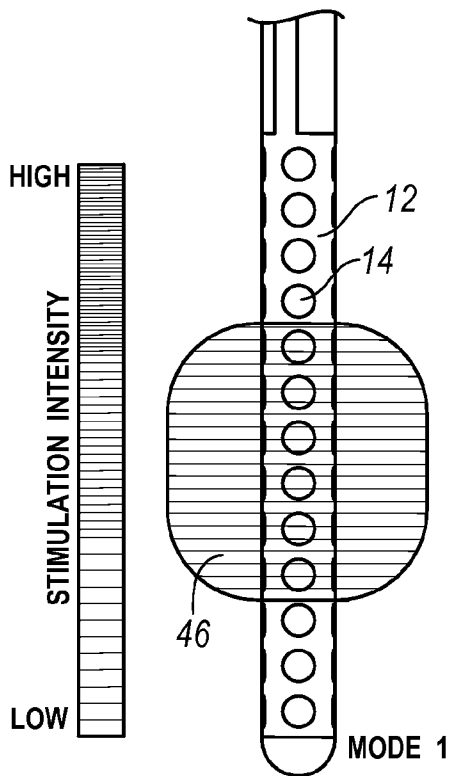

FIG. 4A

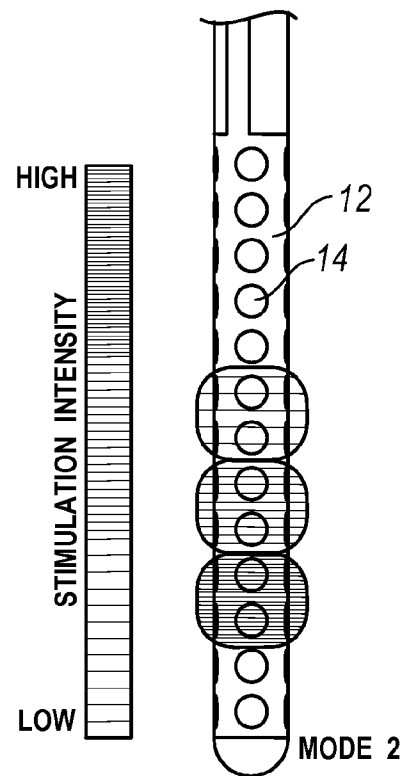

FIG. 4B

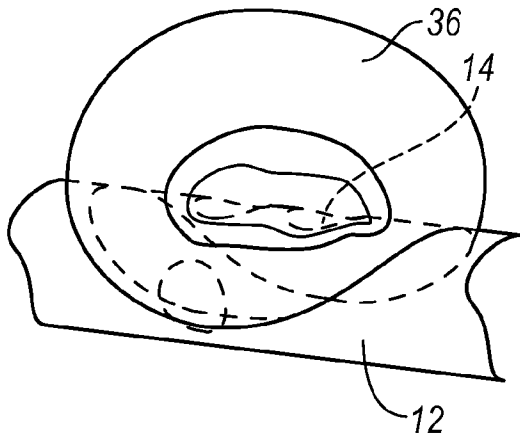

FIG. 5A

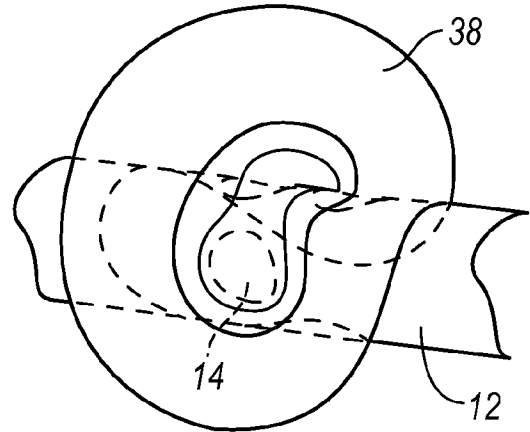

FIG. 5B

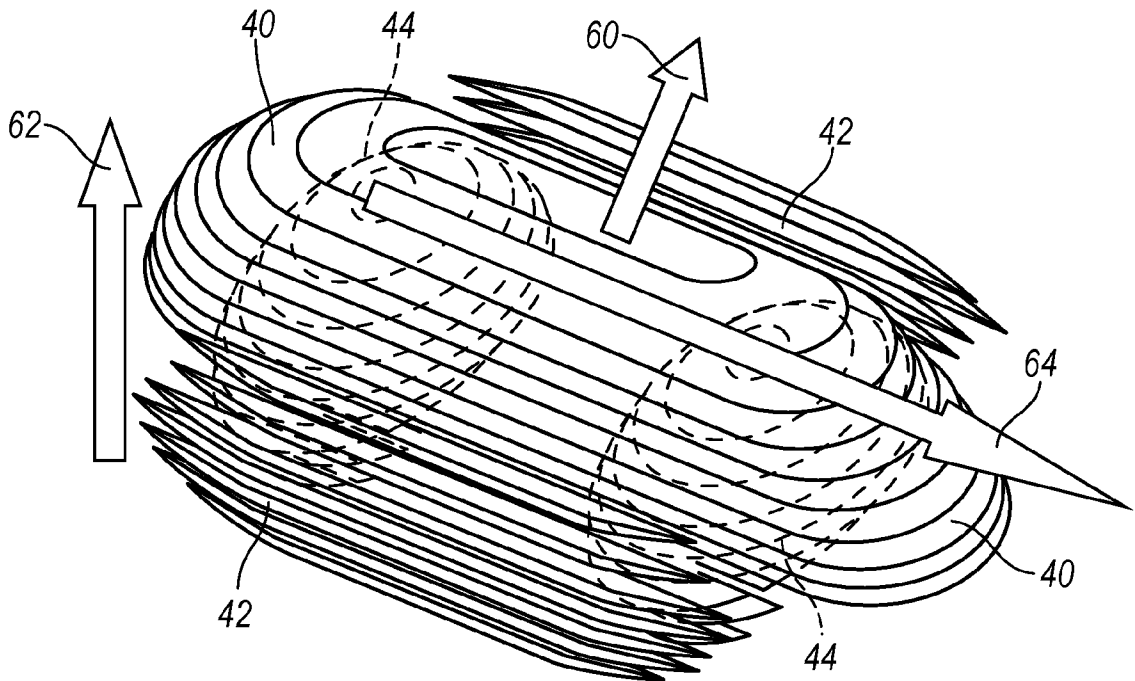

FIG. 6

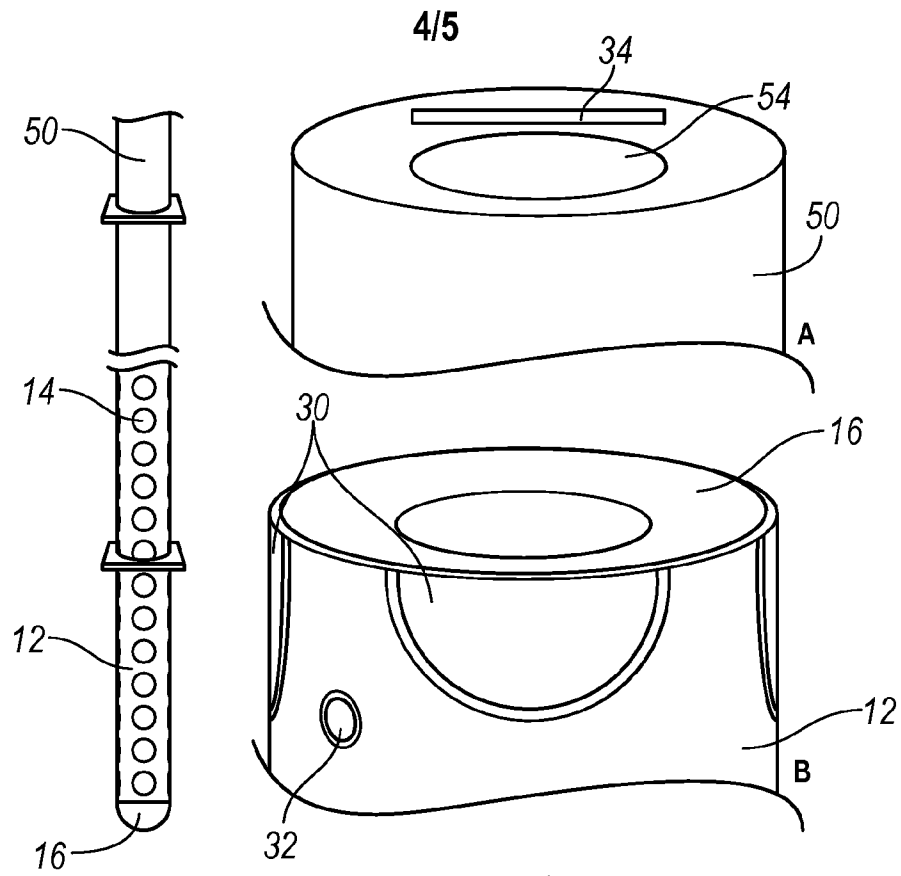

FIG. 7

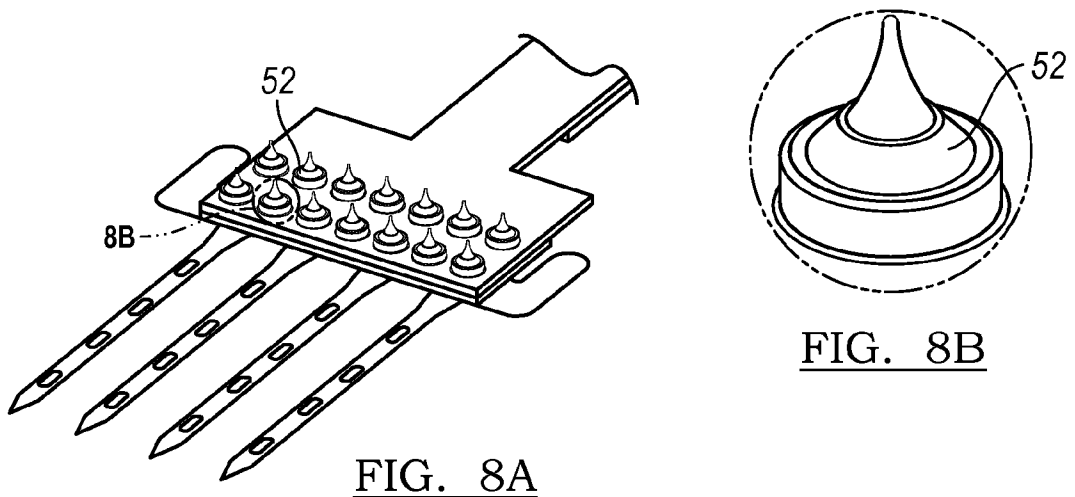

FIG. 8A

FIG. 8B

5/5

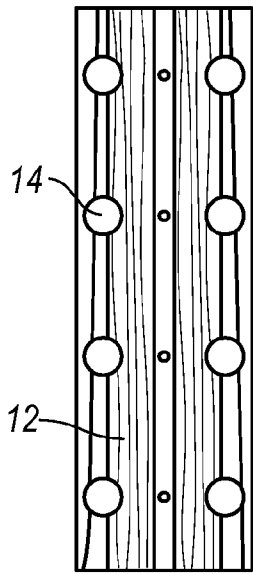

FIG. 9A

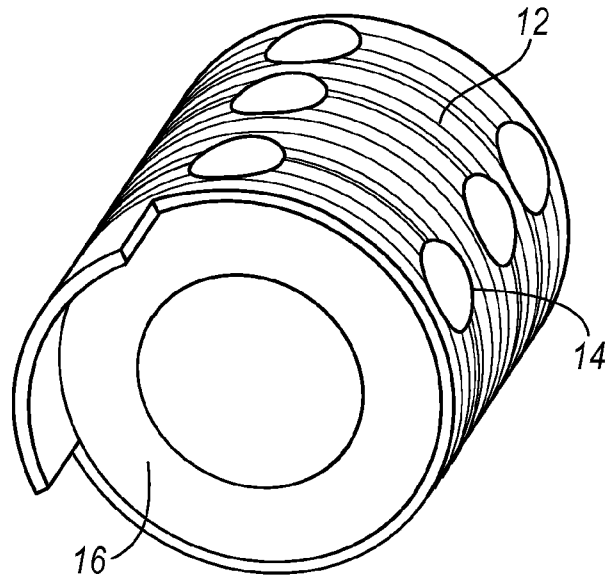

FIG. 9B

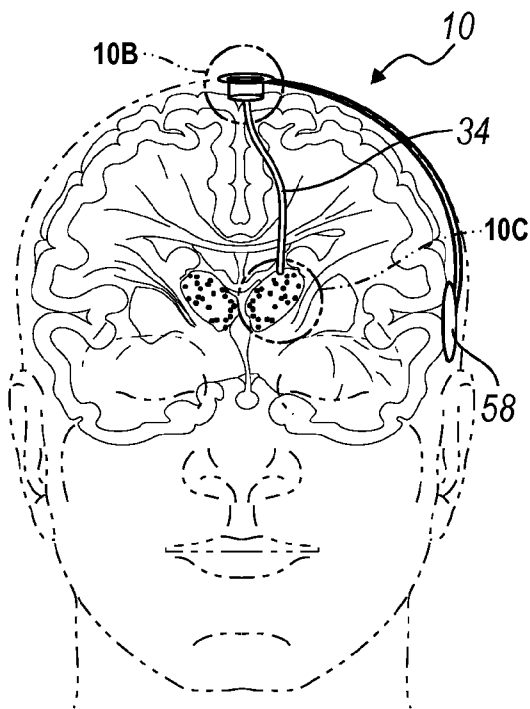

FIG. 10A

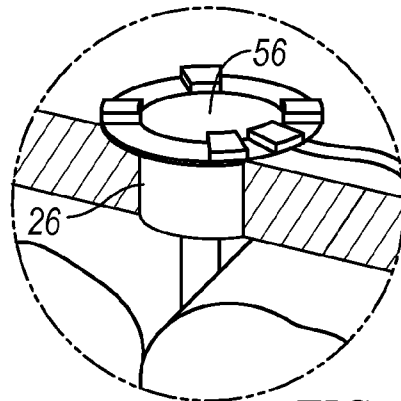

FIG. 10B

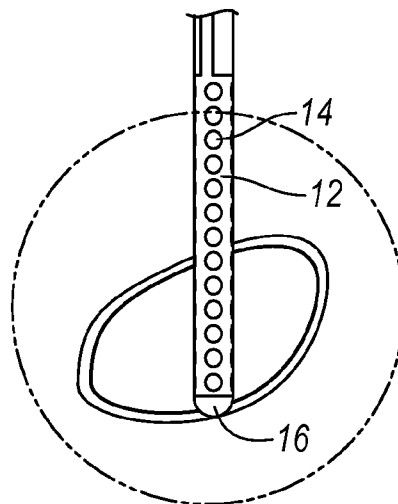

FIG. 10C