



- (51) International Patent Classification: *A47B 57/36* (2006.01) *E06C 1/393* (2006.01)
- (21) International Application Number: PCT/US2017/022954
- (22) International Filing Date: 17 March 2017 (17.03.2017)
- (25) Filing Language: English
- (26) Publication Language: English
- (30) Priority Data: 62/310,755 20 March 2016 (20.03.2016) US
- (71) Applicant: **HIDEAWAY SOLUTIONS LLC** [US/US];  
23 Old Main Road, Little Compton, RI 02837 (US).
- (72) Inventor: **PINNOCK, Lancelot, Jerome**; 23 Old Main Road, Little Compton, RI 02837 (US).
- (74) Agent: **DENNINGER, Douglas, E.**; PO Box 9411, Fall River, MA 02720 (US).
- (81) Designated States (*unless otherwise indicated, for every kind of national protection available*): AE, AG, AL, AM, AO, AT, AU, AZ, BA, BB, BG, BH, BN, BR, BW, BY, BZ, CA, CH, CL, CN, CO, CR, CU, CZ, DE, DJ, DK, DM, DO, DZ, EC, EE, EG, ES, FI, GB, GD, GE, GH, GM, GT, HN, HR, HU, ID, IL, IN, IR, IS, JP, KE, KG, KH, KN, KP, KR, KW, KZ, LA, LC, LK, LR, LS, LU, LY, MA, MD, ME, MG, MK, MN, MW, MX, MY, MZ, NA, NG, NI, NO, NZ, OM, PA, PE, PG, PH, PL, PT, QA, RO, RS, RU, RW, SA, SC, SD, SE, SG, SK, SL, SM, ST, SV, SY,

[Continued on next page]

(54) Title: LATERAL FOLDING STEP UNIT

(57) Abstract: A step unit including a vertical frame and a plurality of linkages pivotally attached at different heights to the vertical frame by one end of each of the linkages, to provide lateral rotation to the linkages. A leg frame, with at least one leg, is pivotally attached to the opposite end of each linkage whereby laterally translating the leg frame simultaneously pivots the linkages from a first, vertical position to at least one second, horizontal position.

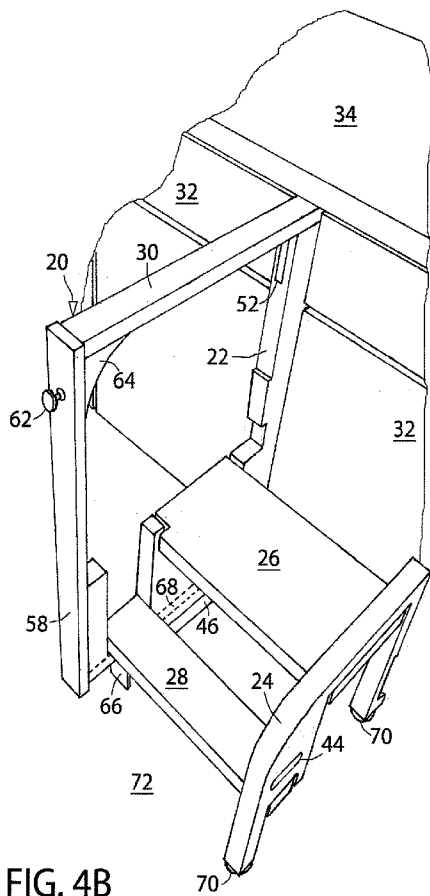

WO 2017/165219 A1

TH, TJ, TM, TN, TR, TT, TZ, UA, UG, US, UZ, VC,  
VN, ZA, ZM, ZW.

SI, SK, SM, TR), OAPI (BF, BJ, CF, CG, CI, CM, GA,  
GN, GQ, GW, KM, ML, MR, NE, SN, TD, TG).

**(84) Designated States** (*unless otherwise indicated, for every kind of regional protection available*): ARIPO (BW, GH, GM, KE, LR, LS, MW, MZ, NA, RW, SD, SL, ST, SZ, TZ, UG, ZM, ZW), Eurasian (AM, AZ, BY, KG, KZ, RU, TJ, TM), European (AL, AT, BE, BG, CH, CY, CZ, DE, DK, EE, ES, FI, FR, GB, GR, HR, HU, IE, IS, IT, LT, LU, LV, MC, MK, MT, NL, NO, PL, PT, RO, RS, SE,

**Published:**

- *with international search report (Art. 21(3))*
- *before the expiration of the time limit for amending the claims and to be republished in the event of receipt of amendments (Rule 48.2(h))*

## **Lateral Folding Step Unit**

### **CROSS-REFERENCE TO RELATED APPLICATION**

[0001] This application claims priority to U.S. Provisional Application No.  
5 62/310,755 filed 20 March 2016. The entire contents of the above-mentioned application is incorporated herein by reference.

### **FIELD OF THE INVENTION**

[0002] This invention relates to a unit having collapsible steps, and more particularly to a lateral folding step unit.

10

### **BACKGROUND OF THE INVENTION**

[0003] Step units such as step stools are essential for people of all heights to help in accessing areas that are vertically out of their reach. Step units can help children reach standard height work surfaces and sinks. However, step stools can be a nuisance to handle, to  
15 store, and to retrieve from storage. Faced with the time it often takes someone to find and access a step stool, wherever it is kept, they are often tempted to use something else. It may be more convenient to find a substitute without the proper step-up height, stability or weight support, such as a chair, making the task less safe with more strain on the user.

[0004] There are two major types of step stools: portable step stools and fixed step  
20 stools. Portable step stools that are not collapsible take up usable space while collapsible designs can be awkward to use and often difficult to collapse when ready to be stored again. They often are not designed with a hand rail which would allow a level of stability especially with types of step stools having more than one step. Also, these step stools potentially do not offer the stability or slip resistance of a fixed step stool.

[0005] Fixed step stools such as those accessed within a storage cabinet, under a sink  
25 or in the kick plate area of a cabinet are more convenient than portable ones but only have the ability to access the one area above where they are installed. Some are mounted very low, near or on the floor, making it necessary for the user to use their foot to operate them or bend over in order to use them. Those mounted within the cabinets can take up valuable space or  
30 limit access within the cabinet.

[0006] Taking into account these short-comings of the prior art, it would be desirable to have a useful step stool with a designated integrated location, where one would use a step stool the most. It would be beneficial to enable a more usable working area than just the one

position a fixed step stool provides. A slim profile would take up minimum space. A step stool that would provide a convenient deploying and operating height would aid and quicken usability. One that would be able to be deploy in front of an appliance would increase its usability. Also, one with the added safety of an integrated hand rail would improve on step  
5 stool prior art.

### SUMMARY OF THE INVENTION

[0007] An object of the present invention is to provide an improved collapsible step unit having a slim storage profile yet easy deployment.

10 [0008] A further object of the invention is to provide such a step unit having suitable step-up height, stability and weight support when deployed.

[0009] Another object of the present invention is to provide collapsible step units capable of having an integrated hand rail and at least one or two usable positions from the step unit's integrated location.

15 [00010] This invention features a step unit, and method of using same, including a vertical frame and a plurality of linkages pivotally attached at different heights to the vertical frame by one end of each of the linkages, to provide lateral rotation to the linkages. A leg frame, with at least one leg, is pivotally attached to the opposite end of each linkage whereby laterally translating the leg frame simultaneously pivots the linkages from a first, collapsed  
20 "up" or "folded" vertical position to at least one second, "down" or "unfolded" horizontal position that is laterally "sideways" to the first position.

[00011] In some embodiments, at least one linkage is substantially deep to be used as a step. In certain embodiments, each vertical frame, leg frame and linkages of the step unit are capable of being positioned on the same geometric plane in the first, vertical position. In  
25 some embodiments, lateral movement of the vertical frame is restricted. In one embodiment, the vertical frame is moveable in a first direction into a structure and in a second direction out from within the structure. In certain embodiments, the vertical frame is movable on at least one wheel.

[00012] In one embodiment, the structure defines a space between two base cabinets.  
30 In some embodiments, a hand rail is integrated into the top of the vertical frame, above the leg frame. In one embodiment, an operating handle is an integral cut-out in the leg frame. In another embodiment, a latch secures the leg frame in its unfolded position. In one embodiment, a mounting guide attached to a structure is to be used to guide the vertical frame

in and out of the opening. In another embodiment, a guide stop is integrated into the mounting guide. In yet another embodiment, a bumper stop is integrated into the top rear corner of the vertical frame, and the bumper stop is adjustable. In one embodiment, the bumper stop comes into contact with the guide stop when the vertical frame is in its extended position. In certain embodiments, the step unit is capable of being utilized as a staircase.

5 [00013] In certain embodiments, at least two linkages are substantially deep to be used as a step by a user, each of the at least two linkages has a first step surface and a second step surface opposite to the first step surface, and the leg frame is capable of being translated to (1) the second, horizontal position to expose the first step surfaces to the user and (2) a third,  
10 horizontal position to expose the second step surfaces to the user.

### BRIEF DESCRIPTION OF THE DRAWINGS

[00014] In what follows, preferred embodiments of the invention are explained in more detail with reference to the drawings, in which:

15 [00015] FIG. 1 is a schematic perspective view of a lateral folding step unit according to the present invention in its collapsed, retracted stored position between two cabinets;

[00016] FIG. 2 is a perspective view similar to FIG. 1 with the lateral folding step unit in an extended position while still collapsed or "up";

[00017] FIG. 3A is a perspective view of the lateral folding step unit in its extended  
20 and deploying 45 degree left position;

[00018] FIG. 3B is a perspective view of the lateral folding step unit in its extended and deploying 45 degree right position;

[00019] FIG. 4A is a perspective view of the lateral folding step unit in its extended and deployed left usable position;

25 [00020] FIG. 4B is a perspective view of the lateral folding step unit in its extended and deployed right usable position;

[00021] FIG. 5 is a perspective enlarged view of the mounting guide for the lateral folding step unit;

[00022] FIG. 6A is a side view close up of the mounting guide for the lateral folding  
30 step unit as shown more completely in FIG. 6B as a right side view of the lateral folding step unit in its extended position;

[00023] FIG. 7 is a perspective enlarged view of an optional spring assist and locking mechanism for the lateral folding step unit in its extended deployed position;

- [00024] FIG. 8A is a right side view close up of the optional spring assist and locking mechanism of FIG. 8B for the lateral folding step unit in its extended collapsed position;
- [00025] FIG. 8B is a side view of the lateral folding step unit in its extended collapsed position with the spring assist and locking mechanism not yet deployed;
- 5 [00026] FIG. 9A is a side view of the lateral folding step unit in its up extended, install/removal tilt position;
- [00027] FIG. 9B is a side view of the lateral folding step unit in its up extended, removed from cabinet position;
- [00028] FIG. 10A is a right side view close up of an alternative spring assist location  
10 for the lateral folding step unit of FIG. 10B in its up position, also showing an alternative adjustable stop bumper in FIG. 10B;
- [00029] FIG. 11 is a perspective view close up of the adjustable bumper stop for the lateral folding step unit of FIG. 10B;
- [00030] FIG. 12 is a side view of the lateral folding step unit showing a one-leg  
15 alternative embodiment in its up position;
- [00031] FIG. 13 is a side view of the lateral folding step unit showing a three-leg alternative embodiment in its up position;
- [00032] FIG. 14A is a perspective view of an anti-flip position for the lateral folding step unit;
- 20 [00033] FIG. 14B is a perspective view close up of an anti-flip leg catch position for the lateral folding step unit of FIG. 14A;
- [00034] FIG. 15 is a perspective enlarged view of the cabinet mounted bumper guide for the lateral folding step unit;
- [00035] FIG. 16A is a right side view of a lateral folding step unit staircase according  
25 to the present invention in its collapsed, stored position;
- [00036] FIG. 16B is a right side view close up of the pivot area of the lateral folding step unit staircase of FIG. 16A;
- [00037] FIG. 17A is a right side view of the lateral folding step unit staircase in its extended, deployed position;
- 30 [00038] FIG. 17B is a right side view close up of the pivot area of the lateral folding step unit staircase of FIG. 17A;
- [00039] FIG. 18A is a front view of the lateral folding step unit staircase in its stored position mounted to a left sided wall;

[00040] FIG. 18B is a front view of the lateral folding step unit staircase in its stored position mounted to a right sided wall;

[00041] FIG. 18C is an enlarged detail of an anchoring screw in FIG. 18B;

[00042] FIG. 19A is a front view of the lateral folding step unit staircase in its extended and deploying 45 degree right position mounted to a left sided wall;

[00043] FIG. 19B is a front view of the lateral folding step unit staircase in its extended and deploying 45 degree left position mounted to a right sided wall;

[00044] FIG. 20A is a front view of the lateral folding step unit staircase in its extended position mounted to a left sided wall;

10 [00045] FIG. 20B is a front view of the lateral folding step unit staircase in its extended position mounted to a right sided wall; and

[00046] FIG. 21 is a front view of the lateral folding step unit staircase in its extended both right and left position mounted inside the middle of a wall.

15 **DETAILED DESCRIPTION OF THE PRESENTLY PREFERRED EMBODIMENTS**

[00047] This invention may be accomplished by a step unit including a vertical frame and a plurality of linkages pivotally attached at different heights to the vertical frame by one end of each of the linkages, to provide lateral rotation to the linkages. A leg frame, with at least one leg, is pivotally attached to the opposite end of each linkage whereby laterally translating the leg frame simultaneously pivots the linkages from a first, vertical position to at least one second, horizontal position.

[00048] A lateral folding step unit **20** according to the present invention, FIGS. 1-6B, is suitable for integration within a slim vertical space defined between two base cabinets **32**. The step unit's **20** main components include a vertical frame **22**, a hand-operated leg frame **24**, and two step linkages **26**, **28**. All of these components lay on the same geometric flat plane in this construction when step unit **20** is stored in the vertical position illustrated in FIG. 2. All of the components of step unit **20** can be made out of a sheet of rigid material such as wood; however metal, plastic, or a combination of these and/or other suitably rigid materials would be acceptable.

30 [00049] The step unit **20** can be extended out from between the base cabinets **32**, as shown in Fig. 2, and deployed laterally left as shown in FIGS. 3A and 4A, or deployed laterally right as shown in FIGS. 3B and 4B based on the user's elevated access needs. In other words, certain preferred constructions of step units according to the present invention

enable a user to position the step unit in at least two different usable positions after the step unit is extended from its storage location. For ease of illustration, all figure views are shown on the right side, or right perspective side, of the step stool unit and, because of the symmetry of the step stool's design in this construction, the left views would be the same as mirror images thereof.

[00050] In this embodiment of FIGS. 1-6B, the step unit **20** is mounted in the vertical space between two parallel spaced base cabinets **32** that have been laterally separated to accommodate the step unit **20**. This space could be between any fixed structure, for example, one cabinet and one cabinet end panel, or two fixed cabinet end panels or other vertical structure. As shown in FIGS. 5, 6A and 6B, a mounting guide **36** is installed in this space between the width of the two cabinets **32**.

[00051] The term "width" is utilized herein to represent the horizontal distance between two edges of a component such as step linkages **26** or **28**, or edges of adjoining components such as cabinets **32**, as best appreciated when the component is deployed horizontally, that is, parallel to a floor. The term "depth" or "deep" is utilized herein to represent a horizontal distance perpendicular to the width of a component.

[00052] In this construction, mounting guide **36** is installed to be positioned flush to the front, top corner of the base cabinets **32** just underneath the counter top **34**. Mounting holes **40** through the sides of the mounting guide **36** are provided to attach the guide to the cabinets with the appropriate fastener hardware such as screws, bolts, etc. The step unit **20** has a vertical frame **22** which moves in and out of the space between the two cabinets and is guided by the guide channel **36**. The guide channel **36** prevents lateral movement of the vertical frame **22**. A guide stop **38** prevents the vertical frame **22** from traveling past its maximum extended position.

[00053] As best shown in FIGS. 3A and 3B, an upper step linkage **26** and a lower step linkage **28** are pivotally attached to the vertical frame **22**. Both step linkages **26** and **28** are substantially deep enough to be used as a step. When both step linkages **26**, **28** are orientated in the stored position, shown in FIG. 2 and 6B, they are in the same geometric plane as the vertical frame **22**. The lower step linkage **28** is oriented in front of the upper step linkage **26**. The lower step linkage **28** also is mounted lower than the upper step linkage **26**. In this embodiment, the upper step linkage **26** is deeper than the lower step linkage **28** to provide a larger working platform. Both steps linkages **26** and **28** have the same width, best shown in FIGS. 4A and 4B. In a different construction of the step stool unit **20**, one with only one step,

either the upper step linkage 26 or lower step linkage 28 could be substantially shallow to become merely a linkage so as to no longer be used as a step.

[00054] The leg frame 24, best shown in FIGS. 2-4B and 6B, in this construction is formed of two legs and is pivotally connected to both the upper ends of the upper and lower step linkages 26 and 28, respectively. The leg frame 24 lays in the same geometric plane as the upper step linkage 26, lower step linkage 28, and vertical frame 22, when in the stored position. The leg frame 24 frames the top of both the upper and lower step linkages 26 and 28 with the back leg extending down toward the bottom of the back side of the upper step linkage 26. The front leg extends almost midway down the front side of the lower step 28. The bottom of both legs of the leg frame 24 are generally parallel to the floor. Attached to the bottom each leg is an anti-slip foot 70, made preferably out of rubber. An oval shaped opening, substantially sized for an intended user's hand, created in the leg frame 24 is used as a operating handle 44. The operating handle 44 is cut out in the space directly above the lower step linkage 28 and directly in front of the upper step linkage 26 in this construction. An optional magnet latch 52' is located on the rear top portion of leg frame 24. The magnet 52' is installed so it is flush with the surface, best seen in FIG. 6B.

[00055] The following explains how the step linkages 26, 28 are pivotally attached to both the vertical frame 22 and leg frame 24 during assembly of this construction. FIG. 6B best shows the following: When orientated in the stored position, four holes are drilled, end to end, horizontally through the depth of the upper and lower linkage steps 26 and 28. These four holes include, one hole at the bottom of each step linkage 26, 28 and one hole for the top of each step linkage 26, 28. Four holes are then drilled horizontally through the corresponding adjacent position, on either side of the bottom of each step linkage 26, 28, into the vertical frame 22. Four holes are then drilled horizontally through the corresponding adjacent position, on either side of the top of each step linkage 26, 28, into the leg frame 24.

[00056] Connective elements such as shafts 54a, 54b, 54c, 54d, also shown in FIG. 6B, are then inserted through holes in the lower and upper ends of both the steps linkages and through the corresponding adjacent position in the vertical frame 22 and leg frame 24 to allow pivotal rotation. Spacers 56 are also installed surrounding the shafts 54a, 54b, 54c, 54d between the spaces between the steps linkages 26, 28, the vertical frame 22 and the leg frame 24 to produce a clearance for the steps linkages 26, 28, vertical frame 22, and leg frame 24 to operate without touching.

[00057] As shown in FIGS. 2 - 4B and 6B, one way to provide the vertical frame 22 with smooth egress from within the cabinet 32 and along the floor 72, is with the use of wheels 48. However, any appropriate mechanism for the step stool to slide would be acceptable, for example, low friction pads, drawer slides, etc. This embodiment uses a wheel mount bracket 46, two wheels 48, and two axle connections 50. The bracket 46 is attached to bottom of the vertical frame 22 and would preferably be made out of metal. Optional wheel bracket mounting holes 47 on either side of the bracket are elongated to allow height and level adjustments to the step unit 20. Appropriate hardware such as screws or bolts, etc are used to attach the bracket 46 to the vertical frame 22. On the bottom of the wheel mounted bracket 46 are two cut outs, front and back, to allow mounting of two wheels 48. The preferred material choice for the wheels 48 would be rubber but other materials would work, such as plastic, wood, metal etc. These wheels 48 are attached with axle connections 50 through each hole on either side of the wheel mounting bracket 46. A cut out (not shown in drawings) slightly larger than the diameter of the wheels 48 is also made in the bottom of the vertical frame 22 to allow the vertical frame 22 to accept the bracket 46 and wheels 48.

[00058] A hand rail 30 is incorporated at the top of the step stool 20 and the back end connects the upper back portion of the vertical frame 22. The other end of the hand rail 30 , connects to the top of the hand rail bracket 64 with the appropriate hardware. The handrail 30 can be made out of metal, wood, plastic, etc. A cabinet face mount 60 is a thin piece of material, preferable metal, that the step stool cabinet face 58 attaches to. The mount 60 is long enough to attach from the top, front face of the hand rail bracket 64 to bottom of the front face of the vertical frame 22, just above the kick plate cutout, shown in FIG. 6B. On the front face of the kick plate cutout a kick plate 66 is installed to match the adjacent kick plates of the base cabinets 32 as seen in FIGS. 2-4B and 6B. A cabinet face pull handle 62 is attached to the front upper portion of the step stool cabinet face 58 as shown in FIGS. 1-4B and 6B to match the appearance of the cabinets 32 as desired.

[00059] An optional bumper guide 68 attaches at the lower portion of the vertical frame just above the kick plate. The guide 68 runs generally parallel to the floor 72 and runs the depth of the step stool, from the front edge to the back edge of the vertical frame 22. The guide 68 is attached using adhesives or screws and runs on both sides of the vertical frame 22. The guide 68 can be used to guide and protect the step stool as it moves in and out of the cabinets 32 and can be best seen in FIGS. 2-4B and 6B. Alternatively, as shown in FIG. 15, the bumper guide 68' could be two spacers/washers that are mounted in the front, lower area

space between the two cabinet 32. Attaching the guides 68' to the outside side of each cabinet so the guides 68' are facing one another with the appropriate fastener or glue. Each guide 68' enables the vertical frame 22 to glide from the cabinets 32 without rubbing them.

[00060] Lastly, a corresponding magnetic latch 52' that is attached to the leg frame 24 is attached as magnetic latch 52 on the opposite adjacent side to the vertical frame 22, such that magnets in latches 52, 52' only engage each other when the step stool 20 is oriented in the stored position, as shown in FIGS. 2 and 6B. The magnet latches 52, 52' are used to hold the step linkages and leg frame in the stored position. In other constructions, a ball latch, roller latch or any other type of magnetic or mechanical latch could be used as a holding device to encourage step unit 20 to remain in a "vertical" storage position. The magnetic latches 52, 52' can be seen in FIGS. 3A-4B and 6B.

[00061] In this construction, one technique for deploying the lateral folding step unit 20 is as follows. A user typically begins by using the face panel pull handle 62 to pull the vertical frame 22, containing two steps linkages 26, 28, and a leg frame 24, out from the stored location between two cabinets 32, as shown in FIGS. 1 and 2. A guide channel 36 and a bumper guide 68 guide the step unit 20 out of the opening as the step unit 20 is pulled out. When pulled out to the maximum extended position, the bumper stop 42 on the step unit 20, comes into contact with the guide stop 38 as seen in FIGS. 6A, 6B.

[00062] The user then has the choice of deploying the step unit 20 laterally to the left or to the right as shown in FIGS. 3A, 4A and Fig 3B, 4B respectively. This can be done by pulling the operating handle 44 that is integrated into leg frame 24. By pulling laterally in the chosen direction, the leg frame 24 will release from the magnetic latch 52 between the vertical frame 22 and the leg frame 24. In an parallel arced motion, the leg frame 24 will transition away from the vertical frame 22. As the leg frame 24 moves so do the step linkages 26, 28, rotating until the leg frame 24 contacts the floor 72. Through this stage, the step linkages 26, 28 move parallel in relation to each other from the initial vertical "stored" position to the horizontal "in use" position. In the "in use" position the linkage steps 26, 28 are deployed in a staircase fashion making them safe and easy to use. In this embodiment, the upper step linkage 26 is substantially deeper to provide a stable platform as the user performs their task. As the user climbs up the step linkages 26, 28, they can stabilize themselves with the built-in hand rail 30. The hand rail 30 can also be used as a leg brace to aid stability for a taller user, see FIGS. 4A, 4B.

[00063] To move back to the extended stored position shown in FIG. 2, the user would step down off the lateral folding step unit 20, grab the operating handle 44, and with one arched motion reposition the leg frame 24, with the pivotally attached step linkages 26, 28, back within the vertical frame 22. The magnetic latch 52 will automatically engage, as seen in FIG. 6B. Then the user has the choice to return the lateral folding step unit 20 back in its stored position, between the cabinets 32 or to access additional counter top 34 or upper cabinet space. This is done by deploying the leg frame 22 and steps linkages 26 and 28 to the adjacent lateral side, see FIGS. 4A, 4B.

[00064] The step unit 20 can be remove if needed by pulling the step unit 20 out into the extended position, from between the base cabinets 32, shown in FIG. 6B, and pivoting the whole unit so that the front wheel comes of the floor 72, see FIG. 9A. This allows the bumper stop 42 at the back of the unit to clear the guide stop 38. Once the step stool 20 has cleared the guide stop 38, it can be pivoted back down and pulled all the way out, shown in FIG. 9B. The reverse procedure goes for the initial or re-installation of the step unit 20,

[00065] If used incorrectly, or not by the handle, it is possible for the step unit 20 to unfold the wrong way. This can happen if the top half of the leg frame 24 moves laterally, in the intended use direction, before the bottom half does. This causes the leg frame 24 to rotate down instead of transition down parallel to the vertical frame 22. To stop this rotation from going too far, in one construction the leg frame 24 has a built in leg frame catch 82 at the back of the lower side of the rear leg, seen in FIG. 14A and FIG. 14B. A corresponding vertical frame catch 84 is built into the vertical frame 22. The vertical frame 22 catch stops the leg frame 24 when it comes into contact with the leg frame catch 82 also shown in FIG. 14A and FIG. 14B. The user can then easily return the step unit 20 to its stored position.

[00066] One or more of the following components can be used independently or in conjunction with one another when building a step unit according to the present invention, such as the step unit 20. In one construction, a lock 74, FIGS. 7-8B, can be added to prevent to step unit 20 from inadvertently moving back into the base cabinet 32 when the step unit 20 is in use, such as seen in FIG. 7. Other alternative components are the incorporation of one or more springs 76', 76'' that can be used to assist the lifting motion of the step stool 20, such as shown in FIGS. 10A and 10B positioned around shaft 54c to bias step link 26 relative to the leg frame 24. Other constructions include the addition of a bumper stop 42, FIGS. 10B-11, that is adjustable and/or repositionable to allow a user to fine-tune how far outward the step unit 20 travels in its extended position. Additional optional components and configurations

include different number of legs on the leg frame 24, as respectively seen in FIGS. 12 and 13 for one- and three-leg configurations, for example.

[00067] In one construction, the optional lock 74, FIGS. 7-8B, is installed by replacing the upper step linkage bottom shaft 54d with an activating shaft 78. The activating shaft is the same diameter and in the same position as the upper step linkage bottom shaft 54d but extends back further into the rear portion of the vertical frame 22 as seen in FIG. 8B. When the step unit 20 is in its extended position, the lock 74 is positioned along the shaft 78 just in front of the base cabinet 32, shown in FIG. 7. A vertical rectangular cut out slightly larger than the lock 74 is cut out of the vertical frame 22. The lock 74 is rectangular shaped in this embodiment but any elongated shape would work so as to act as a locking cam. The lock 74 can be made out of wood metal, plastic etc.

[00068] When the step unit 20 is in the extended or stored position the lock 74 is in a vertical position stored within the vertical frame 22, such as illustrated in FIGS. 8A-8B. When the step unit 20 is in the extended and then deployed laterally, the lock rotates to a horizontal position or orientation. In this position the lock 74 overhangs the front face of the base cabinets 32 engaging the lock feature as shown in FIG. 7. Shaft lock pins 80 are used to transfer the rotational movement in the shaft 78 from the upper step linkage 26 to the lock 74 itself. The shaft lock pins 80 are installed through one hole drilled perpendicular through both the center axis of the shaft 78 and the thickness of the corresponding upper step linkage 26. The placement of the pin 80 can be generally anywhere along where the shaft 78 goes through the upper step linkage 26. Another shaft lock pins 80 is installed through one hole drilled perpendicular through both the center axis of the shaft 78 and through the thickness of the center of the corresponding lock 74, seen in FIGS. 7 and 8A. The shaft lock pin 80 could be substituted any other fastening mean such as a bolt, rivet, etc.

[00069] The lock 74 is activated when the user deploys the step unit 20 in its extended and deployed right, FIG. 7, or to left usable position (not shown). The lock 74 is deactivated when the user returns the step stool to its extended position, shown FIGS. 8A and 8B, allowing the step unit 20 to move freely into and out of the cabinet 32.

[00070] In one construction, the torsion spring 76 uses the rotational movement of the lock 74 to resist and store rotational energy of the step linkages 26, 28 and leg frame 24. The spring 76, in this embodiment, is installed behind the lock 74 in a rectangular opening in the vertical frame 22, see FIGS. 8A, 8B. The activating shaft 78 goes through the center of the spring's coils. The spring 76 is anchored to the lock 74 and to the vertical frame 22. In this

embodiment a hole is drilled into the back side of the lock 74 where one end of the spring's leg can go into to be restrained. Another hole is drilled into the back of the spring's rectangular opening in the vertical frame 22 where the other end of the spring's leg can go into to be restrained, best shown in FIG. 8A.

5 [00071] In another construction, torsion springs 76', 76'', FIGS. 10A-10B, uses the rotational movement between the upper step linkage 26 and leg frame 24 to resist and store rotational energy of the weight of the step linkages 26, 28 and leg frame 24. This embodiment uses two torsion springs 76', 76'' on either top side of the upper step linkage 26, when looking at the step unit 20 orientated in the up position as seen in FIG. 10B. A larger hole is  
10 drilled horizontally centered around the hole for the shaft 54c and deep enough from either end of the upper step linkage 26 to insert each of the torsion springs 76', 76''. Holes or notches are further needed to restrain the torsion spring's legs in both the upper step linkage 26 and the leg frame 24 shown in FIG. 10A. The torsion springs 76', 76'' will also act and take up the same space as the spacers 56 allowing the spacers 56 to be omitted at these two  
15 points. This same method for the torsion springs 76', 76'' placement can be used at either end of the upper or lower step linkages 26, 28 around the upper and lower step linkage shafts 54a, 54b, 54d. If the lower step linkage shafts 54b and/or 54d are used, the torsion spring leg holes would be drilled into the vertical frame 22 instead of the leg frame 24.

[00072] When utilizing the torsion springs 76', 76'' in one or more of these locations,  
20 the weight of the leg frame 24, upper and lower step linkages 26, 28 is nearly canceled out, thereby allowing the step unit 20 operation to feel near weightless for the user when lifting the handle 44. The torsion spring 76, is activated when the user deploys the step unit 20 in its extended and deployed right (FIG. 7) or left usable position. The one or more torsion springs 76, 76' and/or 76'' are deactivated when the user returns the step stool to its up position,  
25 shown FIGS. 8A, 8B and 10A, 10B, for example.

[00073] For constructions including a bumper stop 42 that is adjustable, such as shown in FIGS. 10B, 11, bumper stop mounting holes 43 are drilled into the top of the rear end of the handrail 30. The bumper stop mounting holes 43 are aligned linearly down the middle of the handrail 30. The bottom of the bumper stop 42 has a pin shaped end made preferably out  
30 of metal, for inserting into the bumper stop mounting holes 43. Both the bumper stop 42 and the bumper stop mounting holes 43 could be threaded so the bumper stop 42 would be screwed into place. The top of the bumper stop 42 should be made out of or coated with

rubber to soften the contact with the guide stop 38, but other rigid material such as metal, plastic etc. Would be acceptable.

[00074] This construction of the bumper stop 42 allows the user to place or screw the bumper stop 42 into one of the front holes to keep the step unit 20 as close the cabinet as possible in the extended deployed position. Alternatively, the user can place or screw the bumper stop 42 into one of the rear holes to have the step unit 20 clear obstacles, such as cabinet handles, pulls or appliances (fridges, dishwashers, etc.) when in the extended deployed position.

[00075] Other constructions include the step unit 20 being built with a different number of legs on the leg frame 24. FIG. 12 shows the step unit 20 with a leg frame 24 containing one leg. This embodiment could be used if a deeper upper or lower step linkages 26, 28 were required. FIG. 13 shows the step unit 20 with a leg frame 24 containing three legs. This embodiment could be used if more support was required between the upper or lower step linkages 26, 28.

[00076] An alternative situation for use of at step unit according to the present invention is as a staircase between floor levels, such as illustrated beginning with FIG. 16A. This type of staircase could be particularly useful in tight living areas, such as an apartment, a tiny house, a house boat or yacht with multiple levels, any multipurpose room, bunk beds, or wherever a staircase can take up valuable space. The bilateral motion of the staircase allows flexible mounting on either side of the area to be accessed. Alternatively if there are two rooms with a dividing wall between the two and each room had a separate upper level, the folding staircase could be mounted within the wall between two spaces. A single step unit 20' staircase with one or more "middle" or intermediate step linkages 27 could then be utilized for both spaces depending on the way it was deployed, as described in more detail below.

[00077] Some additional parameters should be taken into account for the step unit 20' staircase embodiment: a) all the step linkages 26, 27, 28 preferably have the same depth; b) the height difference between each step linkage 26, 27, 28 preferably is the same; c) in the deployed position, such as shown in FIG. 17A, the lower end of the leg frame 24 should have the front leg on the floor 70; d) the upper end of the leg frame 24 should have the rear leg on the second floor 73 (FIG. 17A); e) the leg frame 24 would have substantial load bearing strength, to take into account the span from one level to the next, similar to a normal staircase; f) the vertical frame 22 would be attached to each of the floor 72, 73 or to the wall

90 with appropriate hardware. Also, if the vertical frame 22 is to be attached only at its ends at each floor 72, 73, then it would also have substantial load bearing strength to take into account the span from one level to the next.

[00078] With one or more additional intermediate step linkages 27 between the upper and lower step linkages 26, 28, the step unit 20' becomes a staircase for access between one floor 72 and a second floor 73. The following drawings FIGS. 16A - 21 illustrate the step unit 20' staircase main components, which include a vertical frame 22, a hand operated leg frame 24, and multiple step linkages 26, 27, 28. All of these components lay on the same geometric flat plane when stored in the vertical position, see FIGS. 16A, 18A, 18B. All of these component can be made out of a sheet of rigid material such as wood but metal, plastic, or a combination of these and or other rigid materials would be acceptable. The step unit 20' staircase can be deploy laterally right shown in (FIGS. 19A and 20A) when mounted to a wall 90 on the left of a room or laterally left shown in (FIGS. 19B and 20B) when mounted to a wall 90 on the right of a room. Additionally, the step unit 20' staircase can be deploy laterally right or left shown in (FIG. 21) when mounted within a wall 90 between two rooms.

[00079] Best seen in FIGS. 19A and 19B, an upper step linkage 26, intermediate step linkages 27, and lower step linkage 28 are pivotally attached to the vertical frame 22. All step linkages 26, 27, 28 are substantially deep enough to be used as a step. The lower step linkage 28 is oriented in front of the intermediate step linkages 27 and each sequential intermediate step linkage 27 is oriented in front of the upper step linkage 26. The lower step linkage 28 also is mounted lower than the lowest intermediate step linkage 27 and the each sequential intermediate step linkages 27 is mounted lower than the upper step linkage 26 shown in FIGS. 16A and 17A. All steps linkages 26, 27, 28 have the same width best shown in FIGS. 20A and 20B.

[00080] In this construction, leg frame 24, FIG. 16A, has two legs and is pivotally connected to all step linkages 26, 27, 28 respectively. The leg frame 24 lays in the same geometric plane as the upper step linkage 26, intermediate step linkages 27, lower step linkage 28, and vertical frame 22, when in the stored position. The leg frame 24, frames the top of all the step linkages 26, 27, 28 and move up diagonally to the second floor. The back leg raise above the upper step linkage 26 by the height of another step. The front leg extends almost midway down the front side of the lower step linkage 28. Attached to the bottom each leg is an anti-slip foot 70, made preferably out of rubber.

[00081] An oval shaped opening, substantially sized for one's hand, in the leg frame 24 is used as a operating handle 44. One operating handles 44 are cut out in the space directly above one or more of the lower intermediate step linkage 27 and directly in front of the next higher intermediate step linkage 27, seen in FIGS. 16A, 17A. A mechanical or magnet latch 52 can be located anywhere on the top diagonal portion of leg frame 24, preferable near the handle 44. The magnet latch 52 is installed so it is flush with the surface, best seen in FIGS. 16A and 17A. The magnet latch 52 could be substituted with any form of mechanical latch.

[00082] In this staircase embodiment, the following will explain how the step linkages 26, 27, 28 are pivotally attached to both the vertical frame 22 and leg frame 24. The FIG. 16A best shows the following: When orientated in the stored position, two holes are drilled, end to end, horizontally through the depth of the each linkage steps 26, 27 and 28. These two holes include, one hole at the bottom of each step linkage 26, 27, 28 and one hole for the top of each step linkage 26, 27, 28. Holes are then drilled horizontally through the corresponding adjacent position, on either side of the bottom of each step linkage 26, 27, 28, into the vertical frame 22.(FIG. 16B) Holes are then drilled horizontally through the corresponding adjacent position, on either side of the top of each step linkage 26, 27, 28, into the leg frame 24 (FIG 17B).

[00083] A connective component such as a shaft 54 best shown in FIGS. 16A, 16B, 17B, is then inserted through holes in the lower and upper ends of all the steps linkages 26, 27, 28 and through the corresponding adjacent position in the vertical frame 22 and leg frame 24 to allow pivotal rotation. Spacers 56 are also installed surrounding the shafts 54 between the spaces between the steps linkages 26, 27, 28, the vertical frame 22, and leg frame 24 to produce a clearance for the steps linkages 26, 27, 28 , vertical frame 22, and leg frame 24 to operate without touching.

[00084] In this embodiment of the step unit 20' staircase in its up position, a corresponding magnetic latch 52 is attached onto the stair rail 86. It is attached on the opposite adjacent side to the leg frames, magnetic latch 52 position, as shown in FIG. 16A. The magnet latches 52 are used to hold the step linkages 26, 27, 28 and leg frame 24 in the up position. Any other type of magnetic or mechanical latch could be used as a holding device.

[00085] Lastly, the vertical frame 22, can be connected to the wall 90 with bolts 92 or other appropriate hardware, screws, etc. best seen in FIGS. 18A – 20B. If installed within the wall 90, the vertical frame 22 can be sandwiched or built directly into the framing of the wall. The wall 90 can then be built around the step unit 20' staircase.

[00086] During use, the step unit 20' staircase would be folded against a left or right sided wall 90 when not in use shown in FIGS. 16A, 18A, 18B. When access is needed in areas such as a second floor 73 living area or loft, one can pull the operating handle or handles 44 that is integrated into leg frame 24. By pulling laterally, the leg frame 24 will  
5 release from the magnetic latch 52 between the vertical frame 22 and the leg frame 24. In an parallel arced motion, the leg frame 24 will transition away from the vertical frame 22. As the leg frame 24 moves so do the step linkages 26, 27, 28, rotating until the leg frame 24 contacts the lower floor 72 and upper floor 73. Through this stage, the step linkages 26, 27, 28 move parallel in relation to each other from the initial vertical "stored" position to the  
10 horizontal "in use" position, seen in FIGS. 17A and 19A-20B. The top section of the leg frame 24 should come tight against a baluster 88 or wall in the down position as shown in FIGS 20A-21 for safety. Then the step unit 20' staircase can then be used as a conventional staircase. After use, or if more floor space is needed, the step unit 20' staircase can then be returned to its vertical stored position by grabbing the operating handle 44, and with one  
15 arched motion reposition the leg frame 24, with the pivotally attached step linkages 26, 27, 28, back within the vertical frame 22. The magnetic latch 52 will automatically engage, as seen in FIGS. 16A, 18A, 18B.

[00087] The same action is used for a step unit 20' staircase that is folded within a wall 90, but the user then has the choice of deploying the step unit 20' laterally to the left or to the  
20 right as shown in FIG. 21. This would allow access to two lofts or second floor 73 living spaces and the ability to easily store the step unit 20' staircase out of the way for both ground floor rooms.

[00088] Although specific features of the present invention are shown in some drawings and not in others, this is for convenience only, as each feature may be combined  
25 with any or all of the other features in accordance with the invention. While there have been shown, described, and pointed out fundamental novel features of the invention as applied to a preferred embodiment thereof, it will be understood that various omissions, substitutions, and changes in the form and details of the devices illustrated, and in their operation, may be made by those skilled in the art without departing from the spirit and scope of the invention. For  
30 example, it is expressly intended that all combinations of those elements and/or steps that perform substantially the same function, in substantially the same way, to achieve the same results be within the scope of the invention. Substitutions of elements from one described embodiment to another are also fully intended and contemplated. It is also to be understood

that the drawings are not necessarily drawn to scale, but that they are merely conceptual in nature.

[00089] It is the intention, therefore, to be limited only as indicated by the scope of the claims appended hereto. Other embodiments will occur to those skilled in the art and are

5 within the following claims.

## Claims

### What is claimed is:

1. A step unit comprising:
  - a. a vertical frame;
  - b. a plurality of linkages pivotally attached at different heights to the vertical frame by one end of each of the linkages, to provide lateral rotation to the linkages; and
  - c. a leg frame, with at least one leg, pivotally attached to the opposite end of each of the linkages whereby laterally translating the leg frame simultaneously pivots the linkages from a first, vertical position to at least one second, horizontal position.
2. The step unit of Claim 1 wherein at least one linkage is substantially deep to be used as a step.
3. The step unit of Claim 1 wherein each vertical frame, leg frame and linkages of the step unit are capable of being positioned on the same geometric plane in the first, vertical position.
4. The step unit of Claim 1 wherein lateral movement of the vertical frame is restricted.
5. The step unit of Claim 1 wherein the vertical frame is moveable in a first direction into a structure and in a second direction out from within the structure.
6. The step unit of Claim 5 wherein the vertical frame is movable on at least one wheel.
7. The step unit of Claim 5 wherein the structure defines a space between two base cabinets.
8. The step unit of Claim 1 wherein a hand rail is integrated into the top of the vertical frame and is positioned above the leg frame.

9. The step unit of Claim 1 wherein an operating handle is an integral cut-out in the leg frame.
10. The step unit of Claim 1 wherein a latch secures the leg frame in its unfolded position.
11. The step unit of Claim 1 wherein a mounting guide attached to a structure is to be used to guide the vertical frame in and out of the opening.
12. The step unit of Claim 10 wherein a guide stop is integrated into the mounting guide.
13. The step unit of Claim 1 wherein a bumper stop is integrated into the top rear corner of the vertical frame.
14. The step unit of Claim 13 wherein the bumper stop is adjustable
15. The step unit of Claim 12 wherein the bumper stop comes into contact with the guide stop when the vertical frame is in its extended position.
16. The step unit of Claim 1 wherein the step unit is capable of being utilized as a staircase.
17. The step unit of Claim 1 wherein at least two linkages are substantially deep to be used as a step by a user, each of the at least two linkages has a first step surface and a second step surface opposite to the first step surface, and the leg frame is capable of being translated to (1) the second, horizontal position to expose the first step surfaces to the user and (2) a third, horizontal position to expose the second step surfaces to the user.



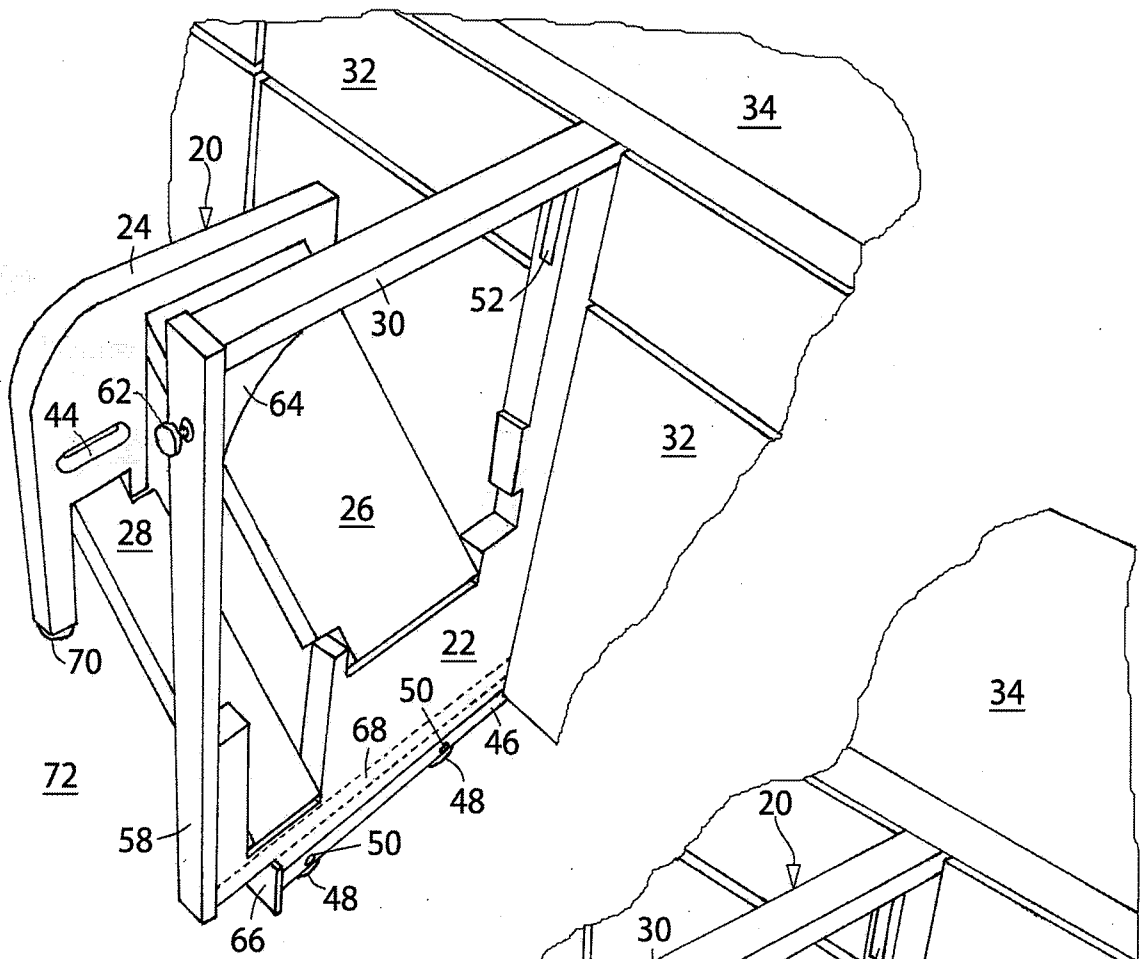

FIG. 3A

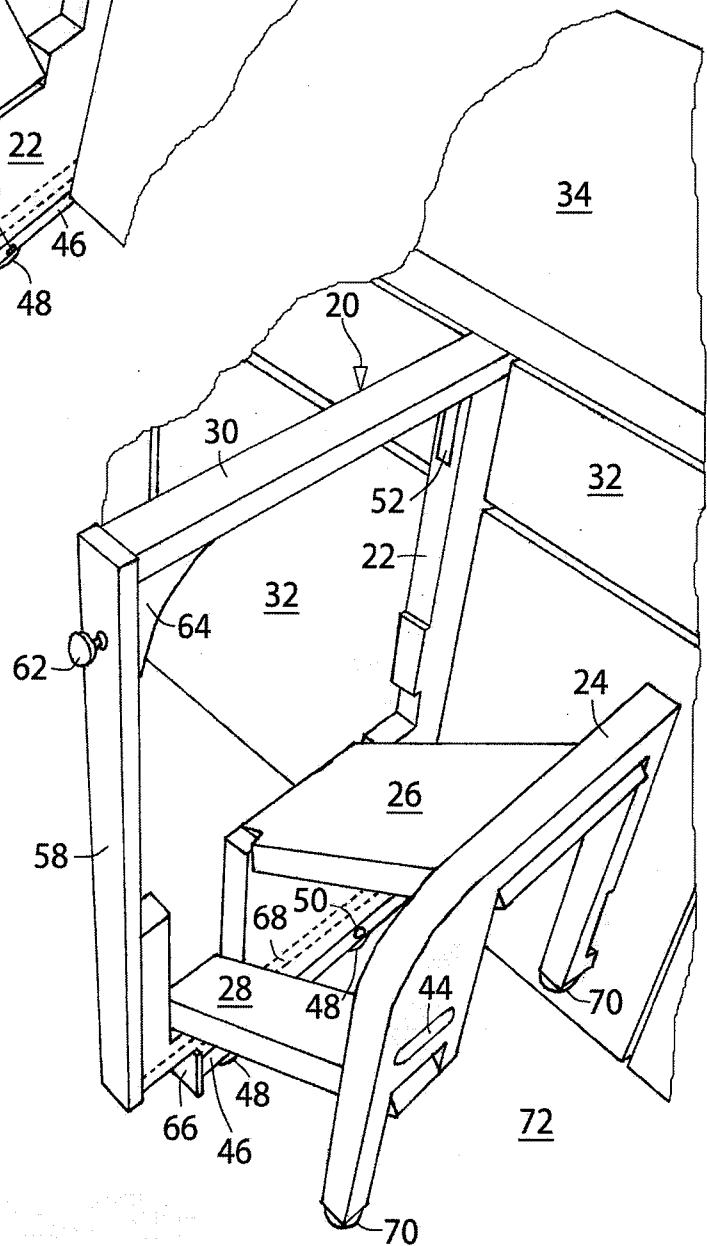

FIG. 3B

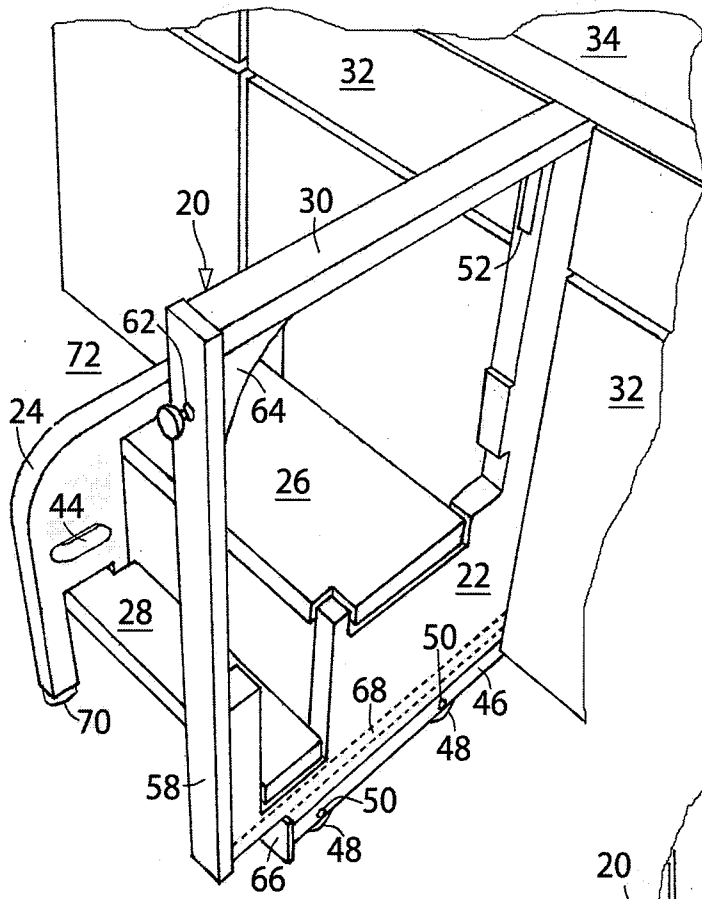

FIG. 4A

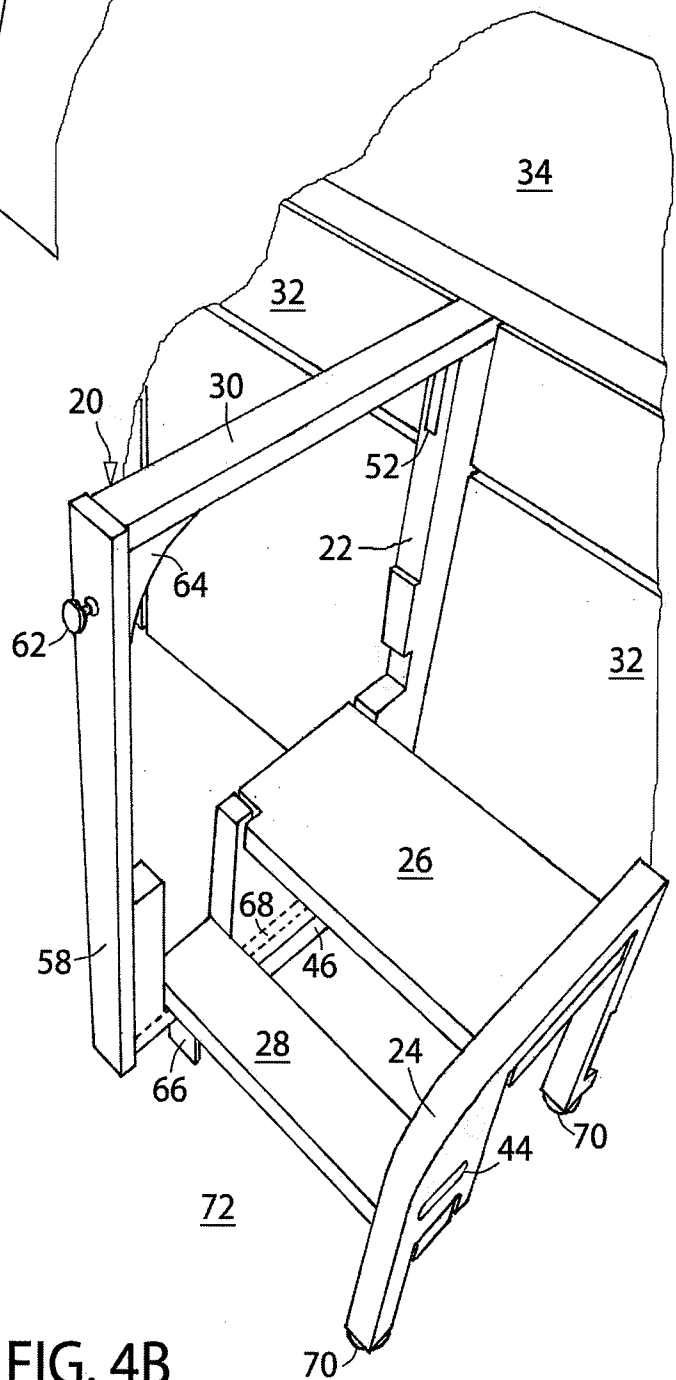

FIG. 4B

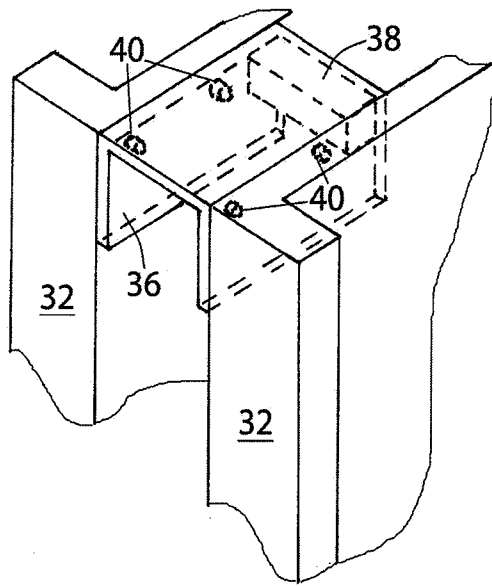

FIG. 5

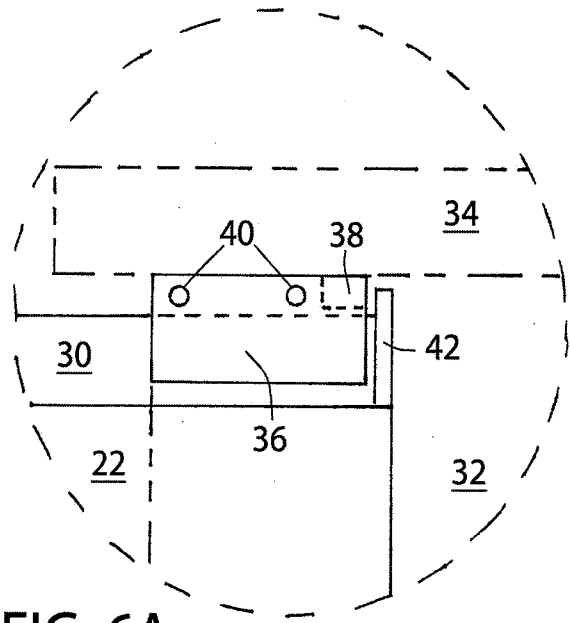

FIG. 6A

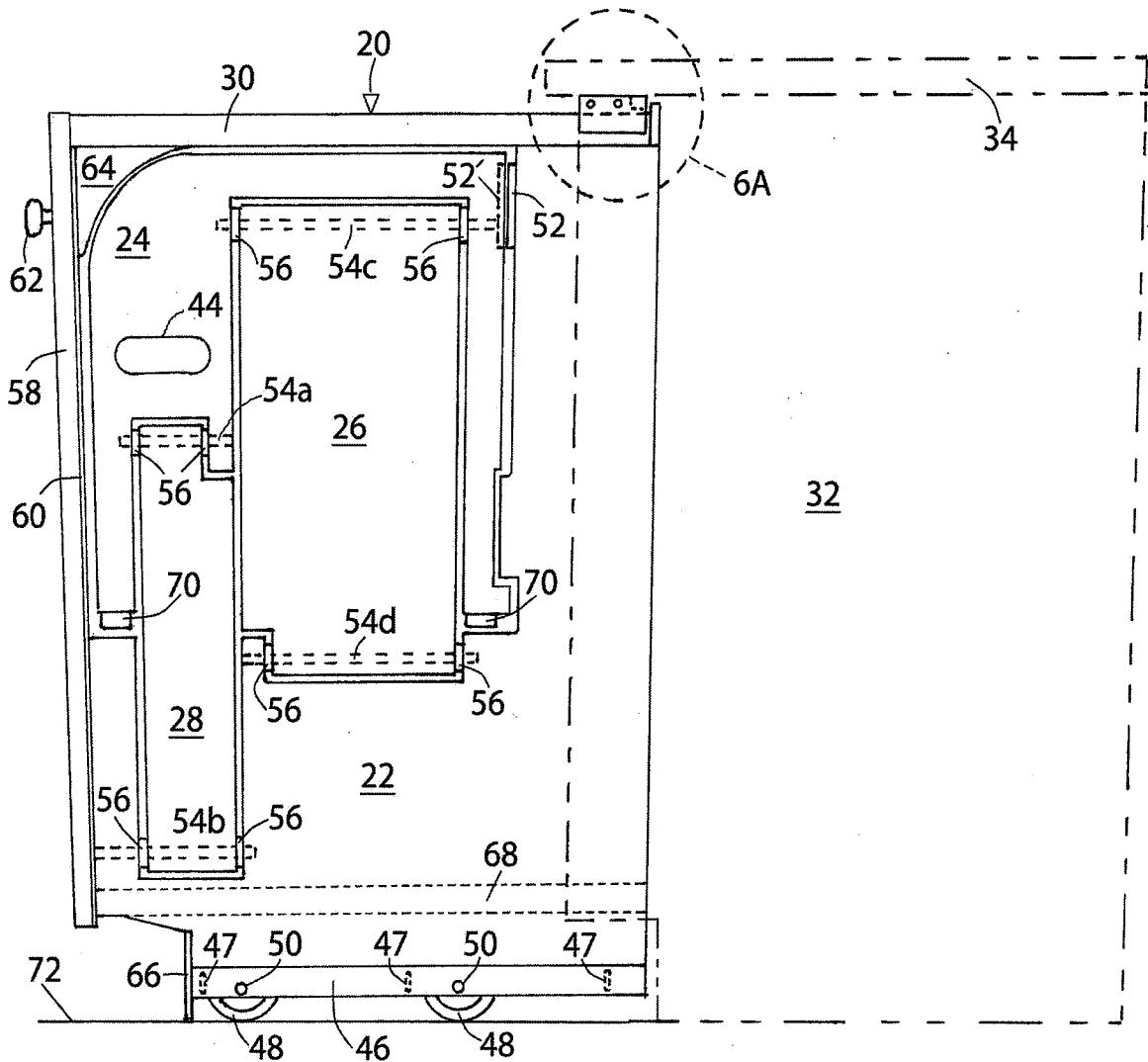

FIG. 6B

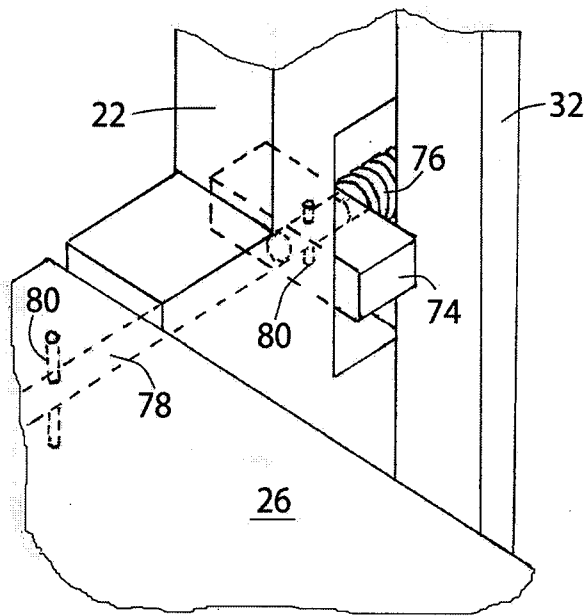

FIG. 7

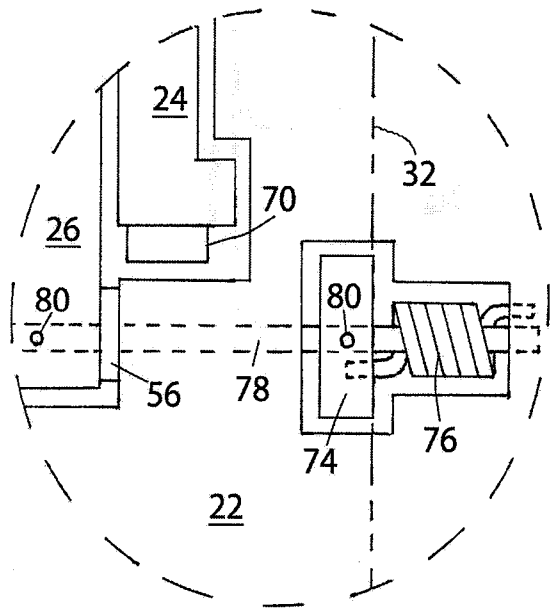

FIG. 8A

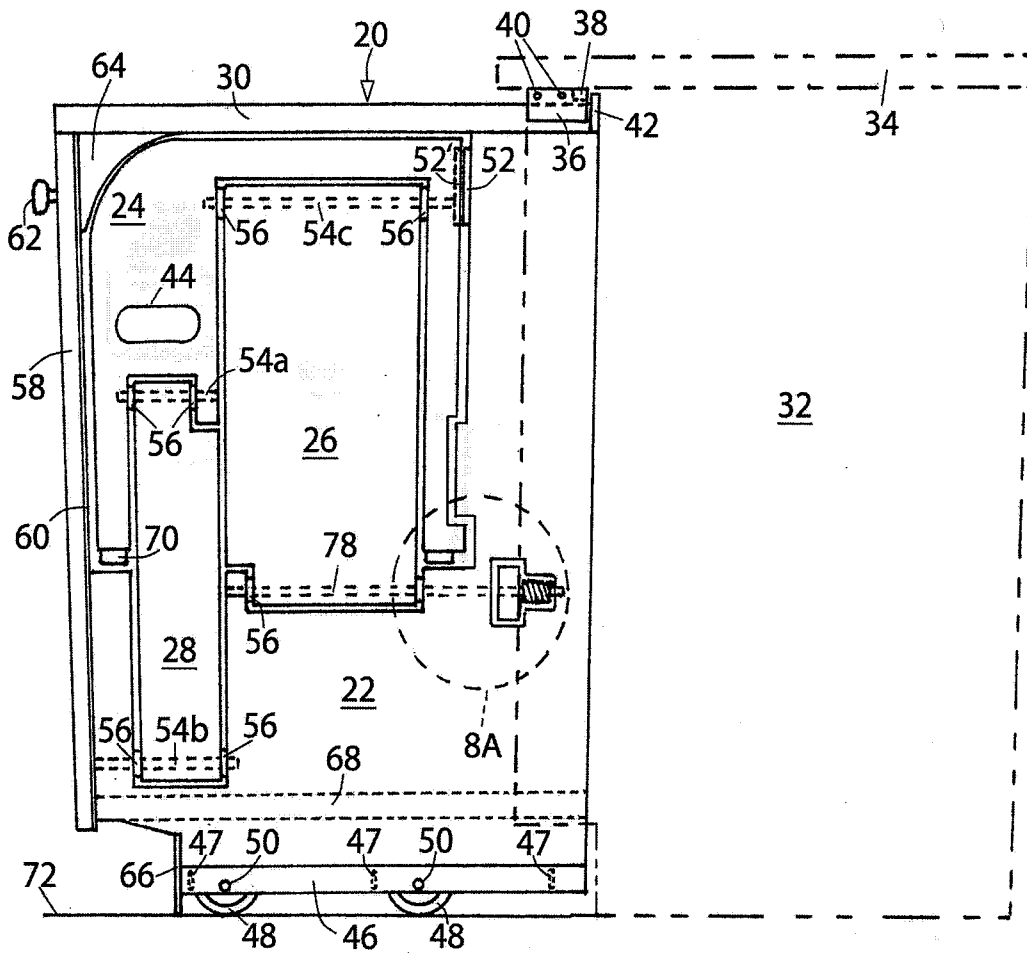

FIG. 8B

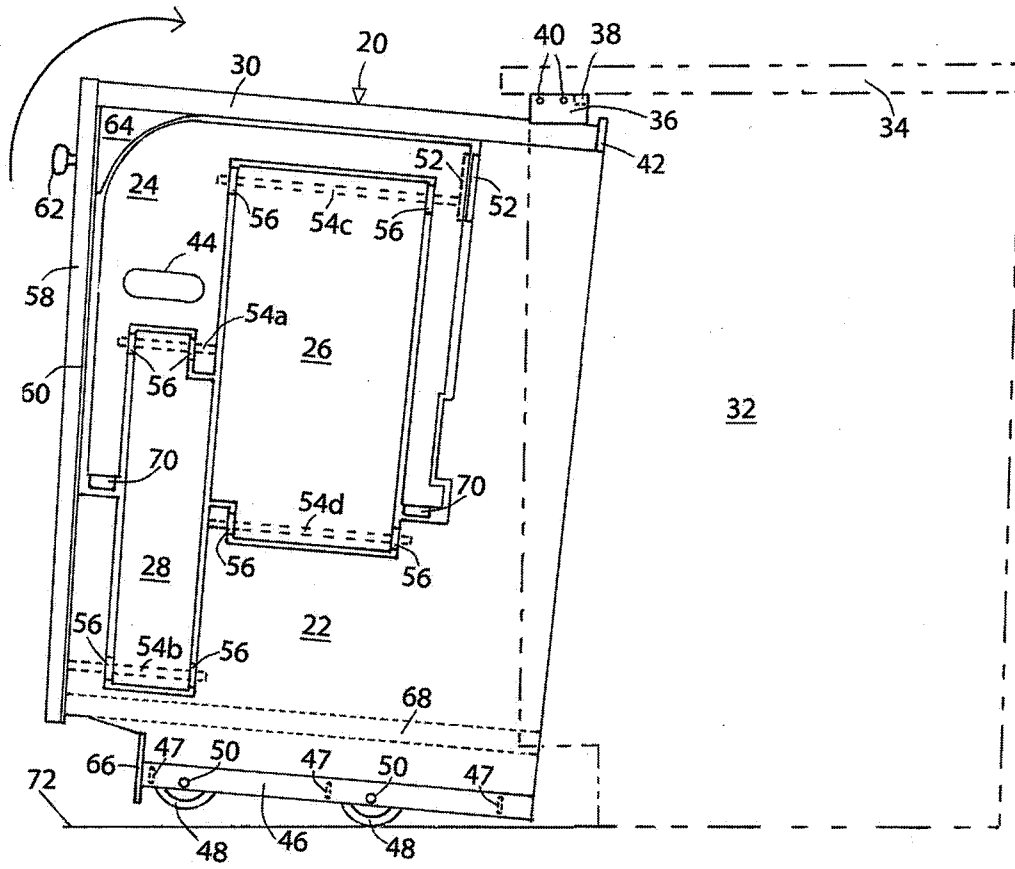

FIG. 9A

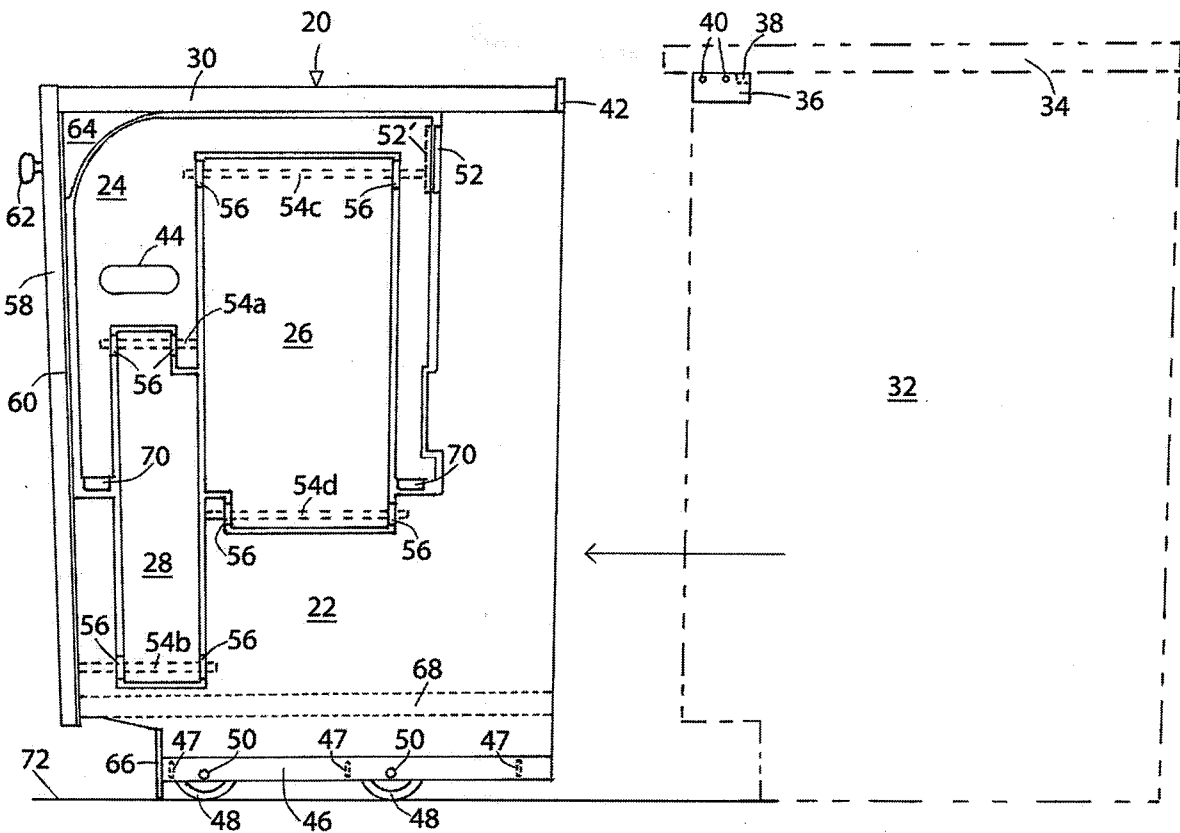

FIG. 9B

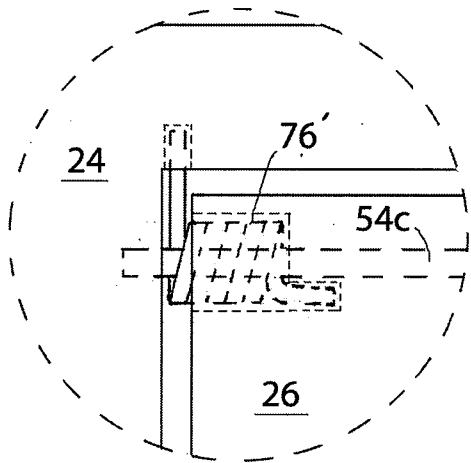

FIG. 10A

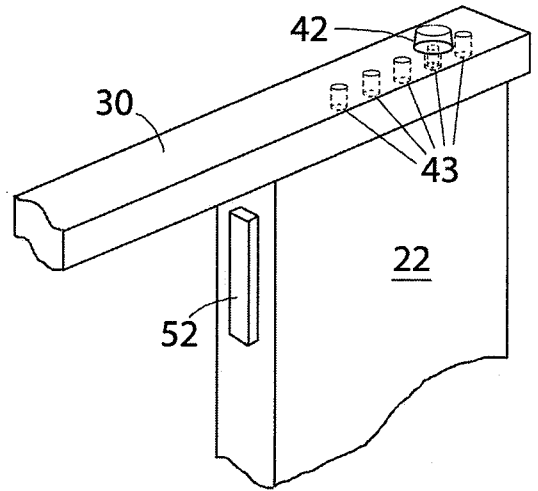

FIG. 11

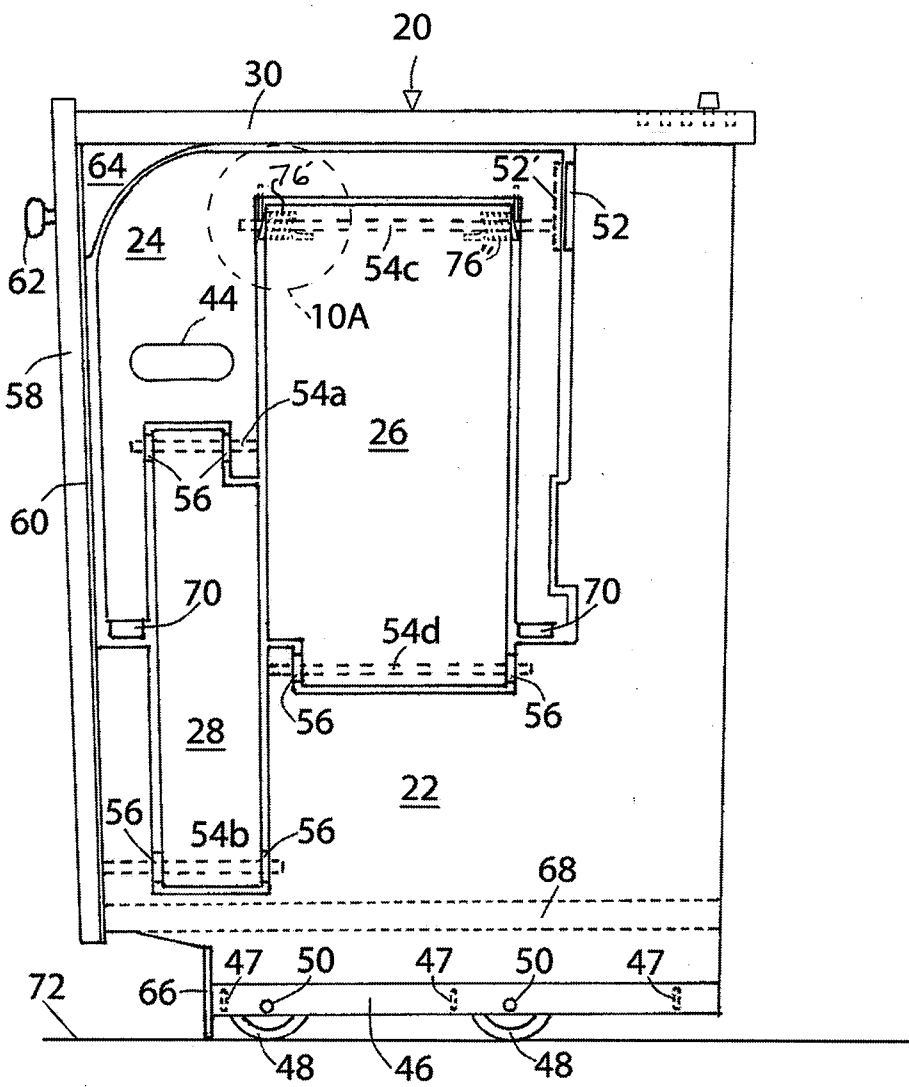

FIG. 10B

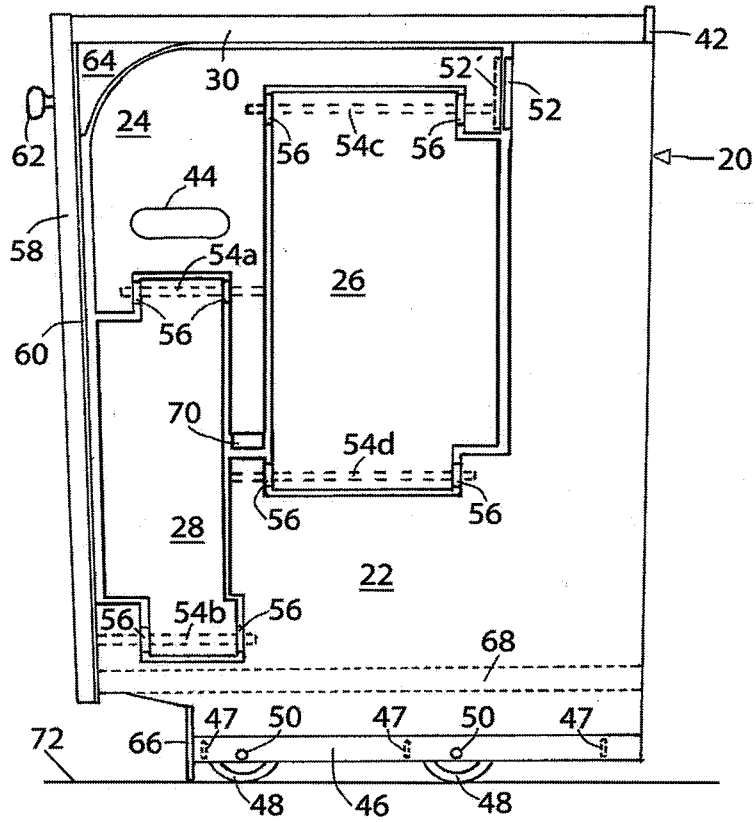

FIG. 12

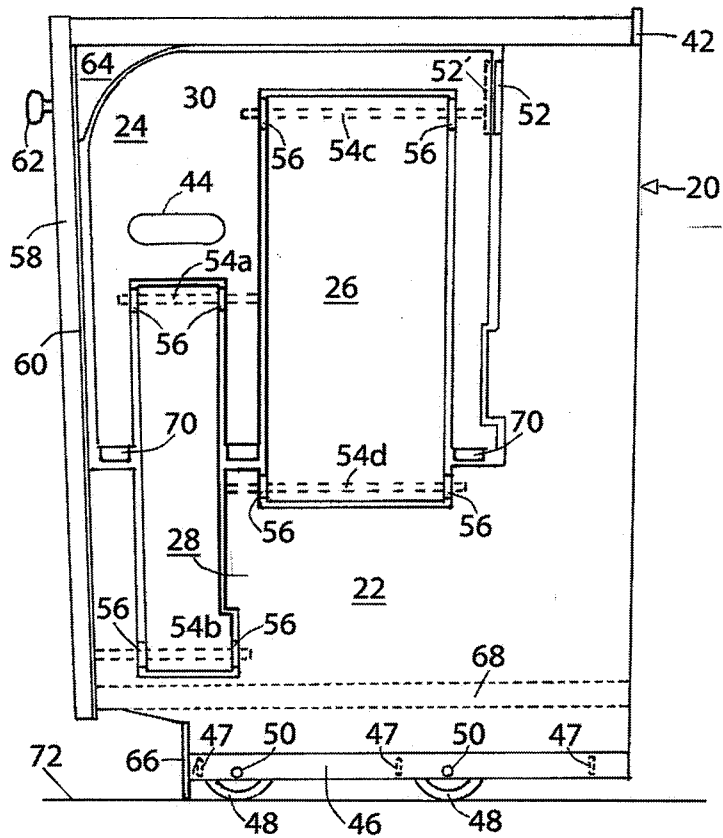

FIG. 13

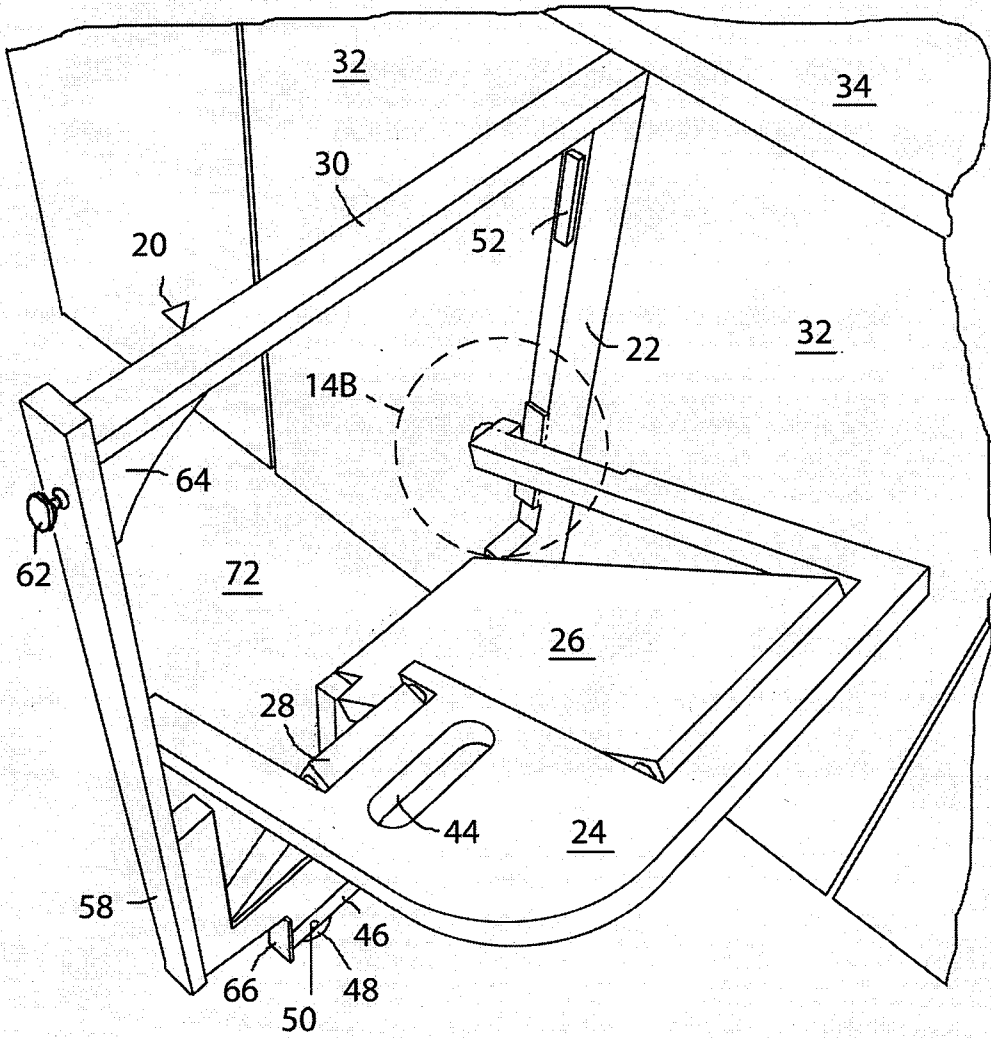

FIG. 14A

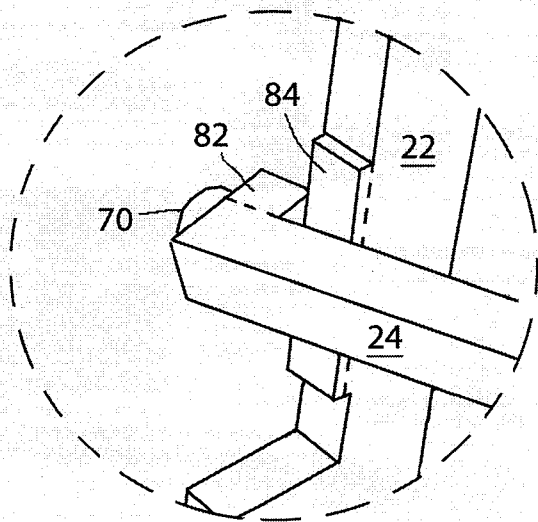

FIG. 14B

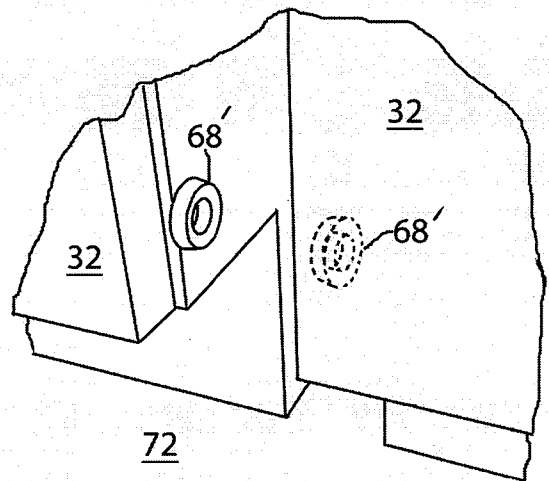

FIG. 15

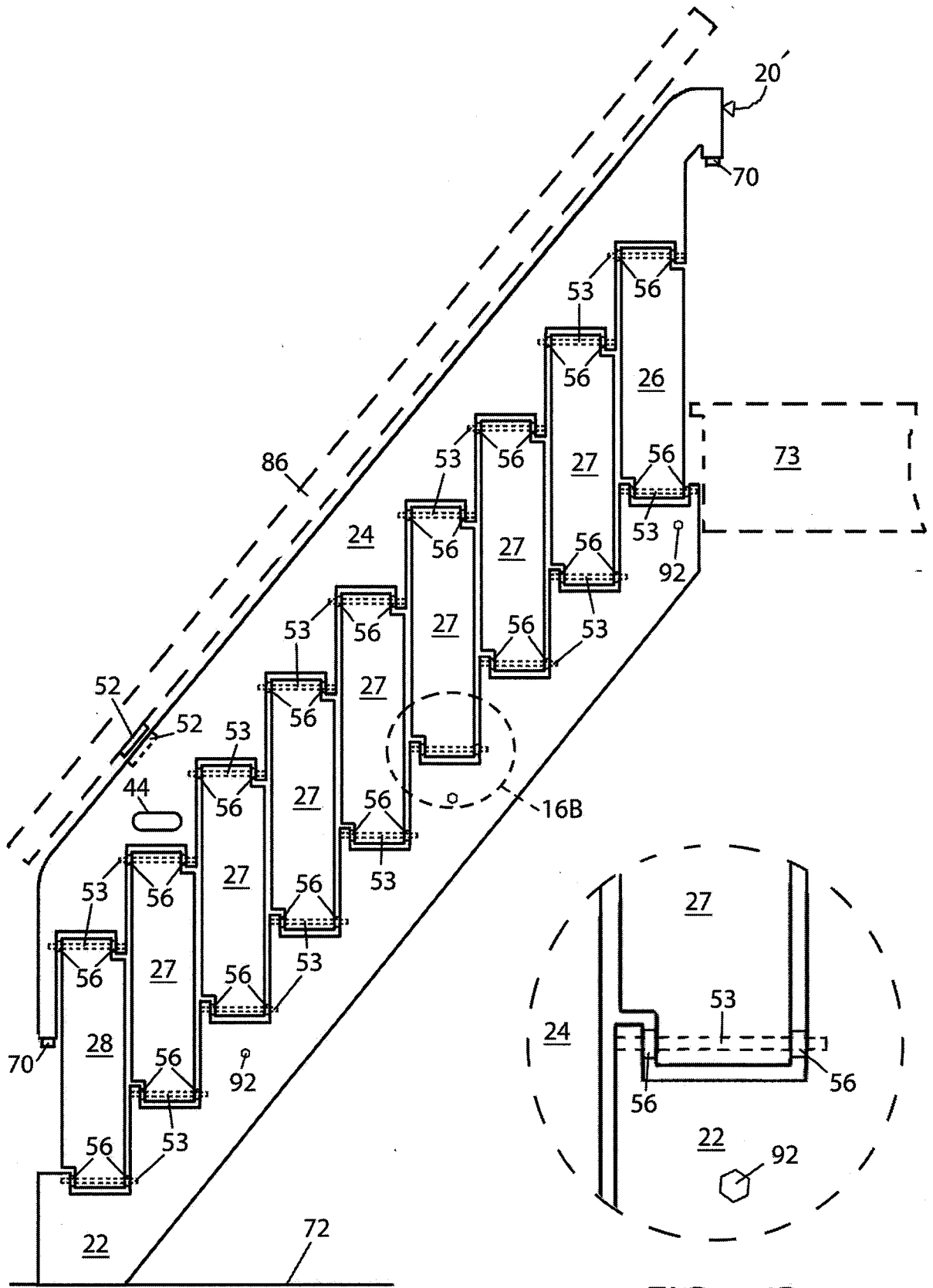

FIG. 16A

FIG. 16B



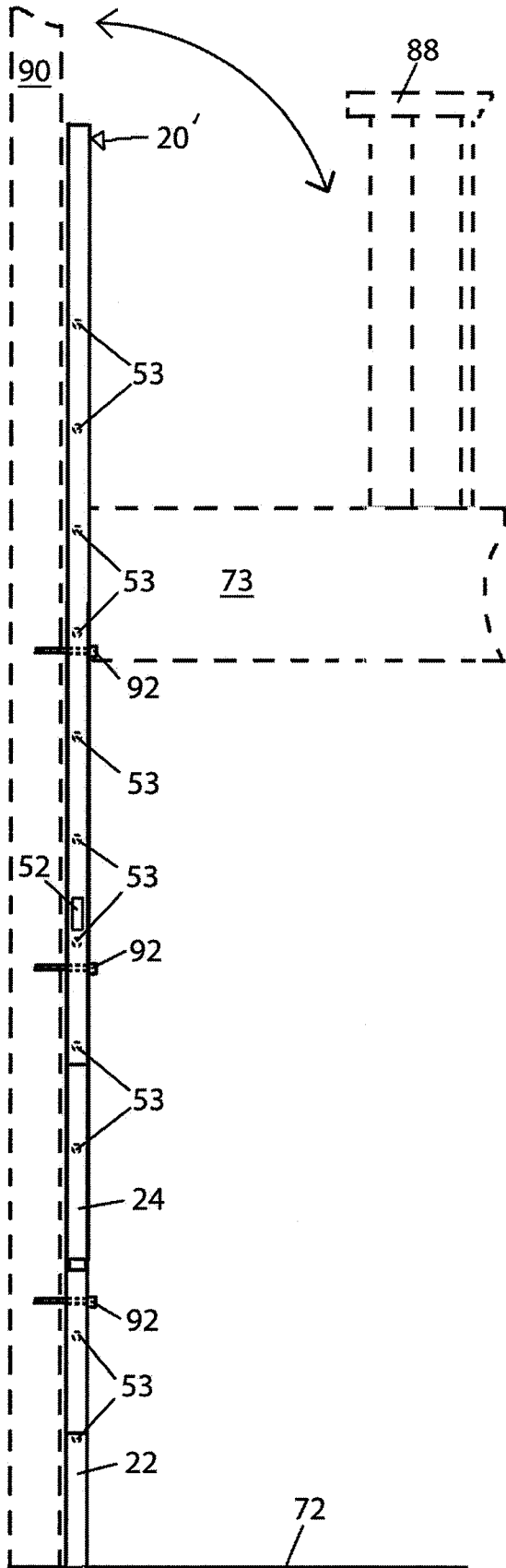

FIG. 18A

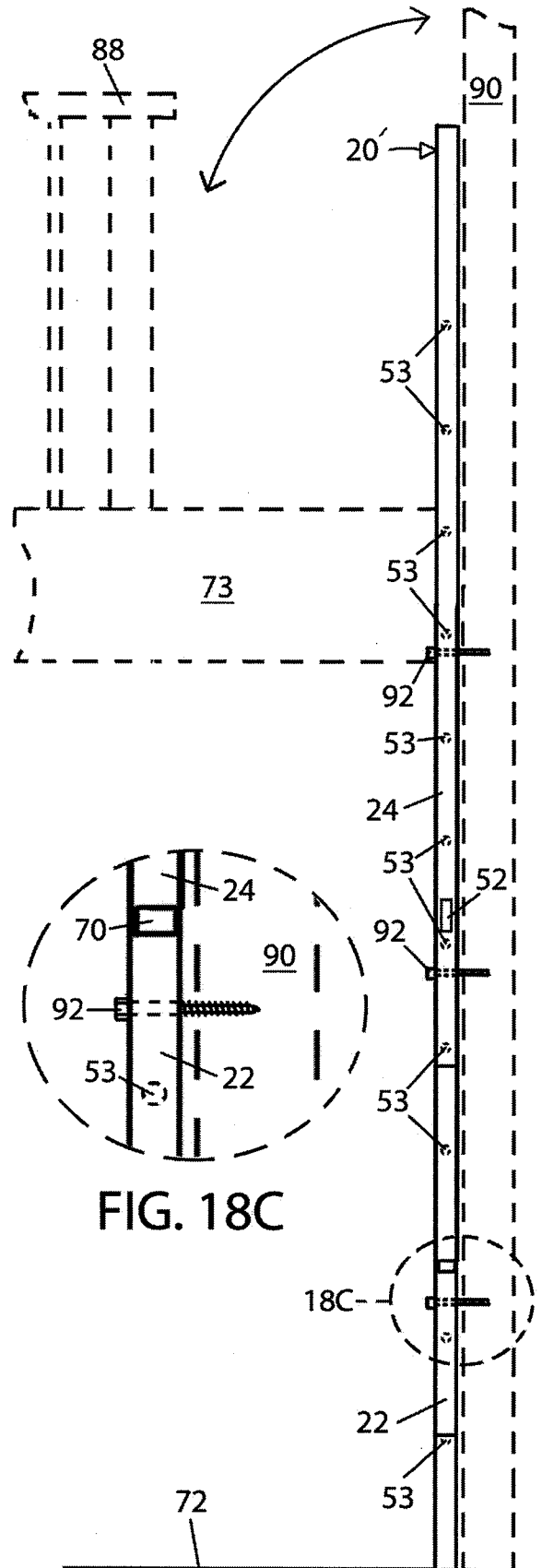

FIG. 18B

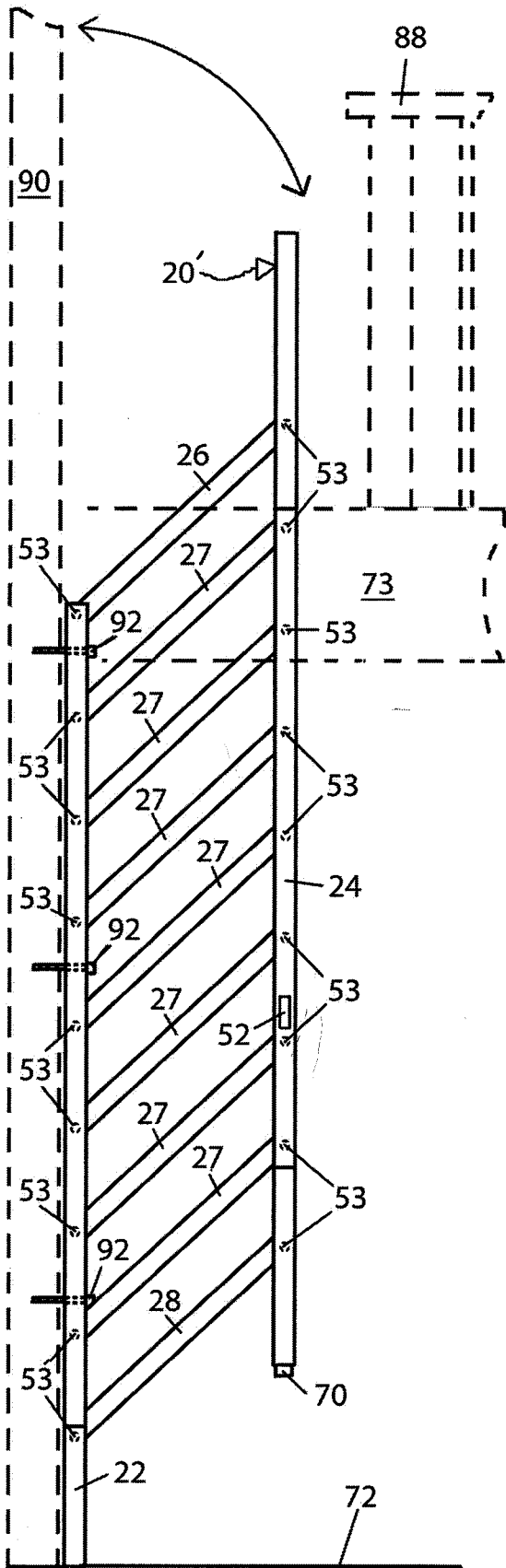

FIG. 19A

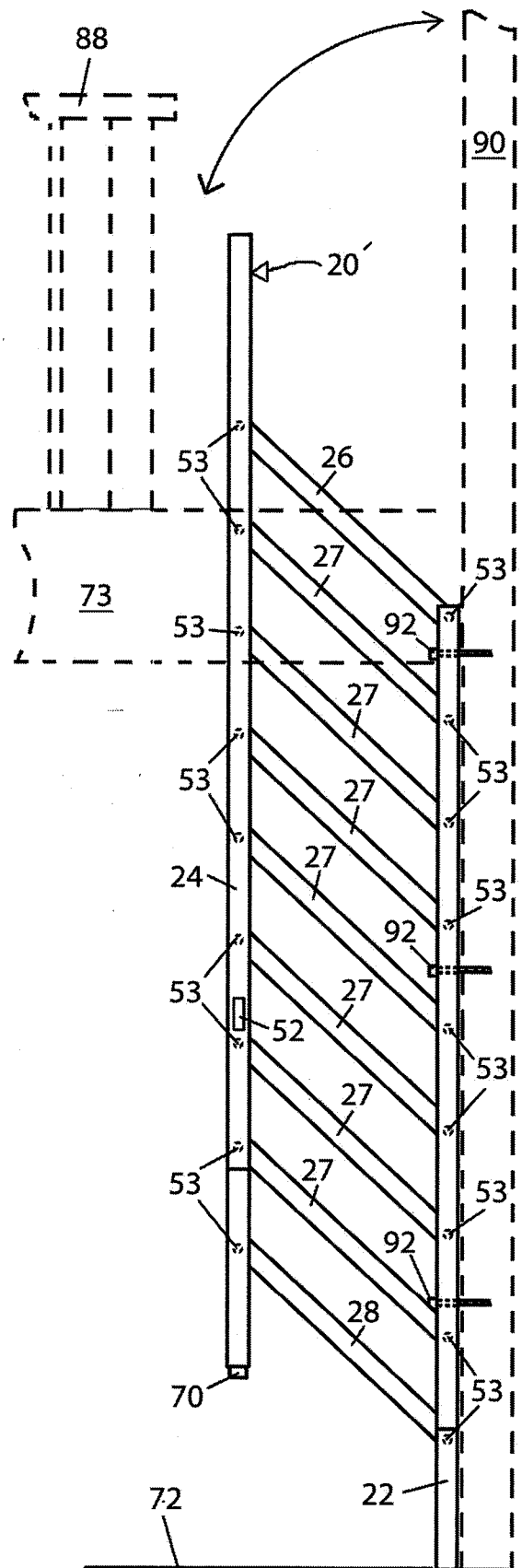

FIG. 19B

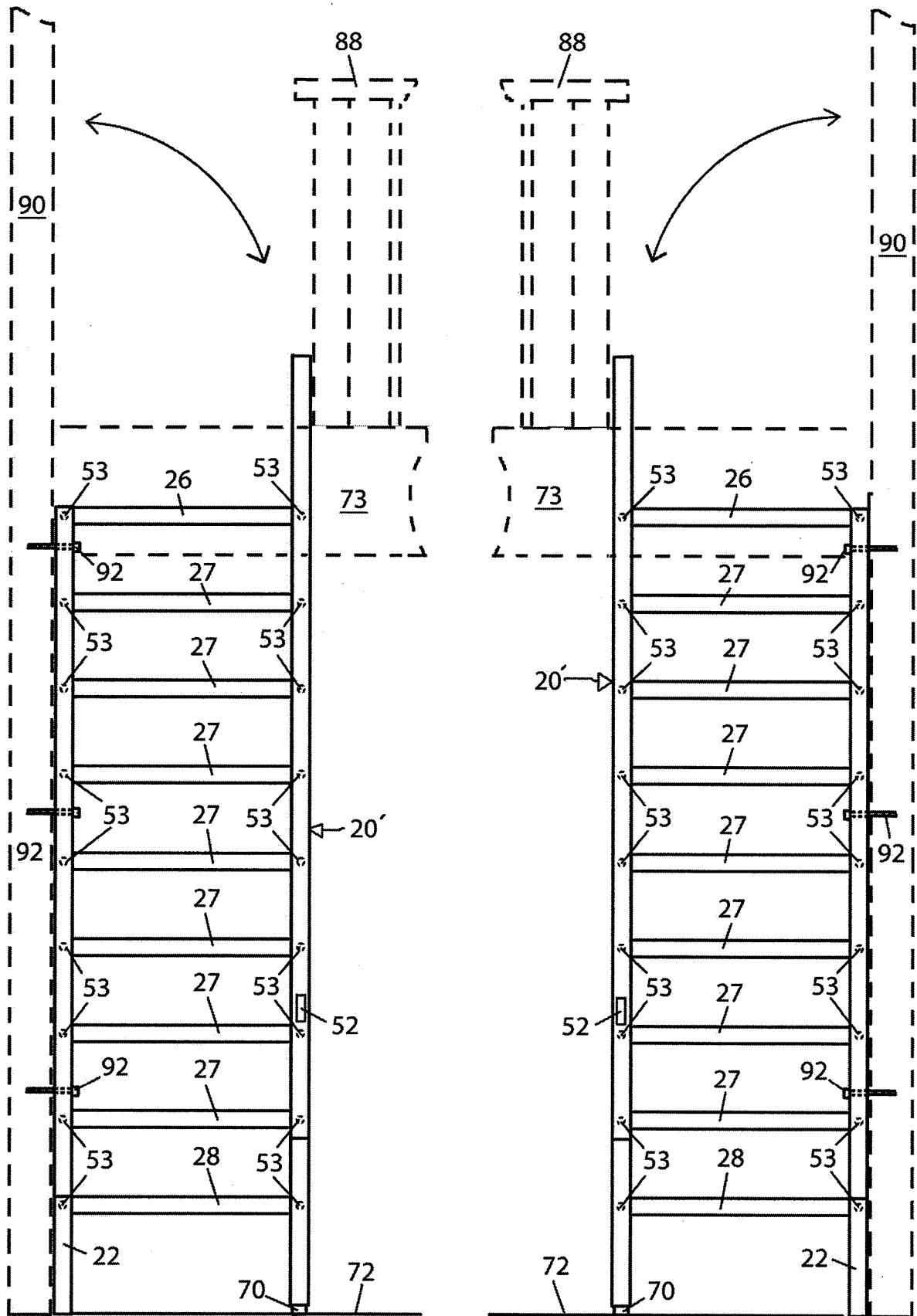

FIG. 20A

FIG. 20B

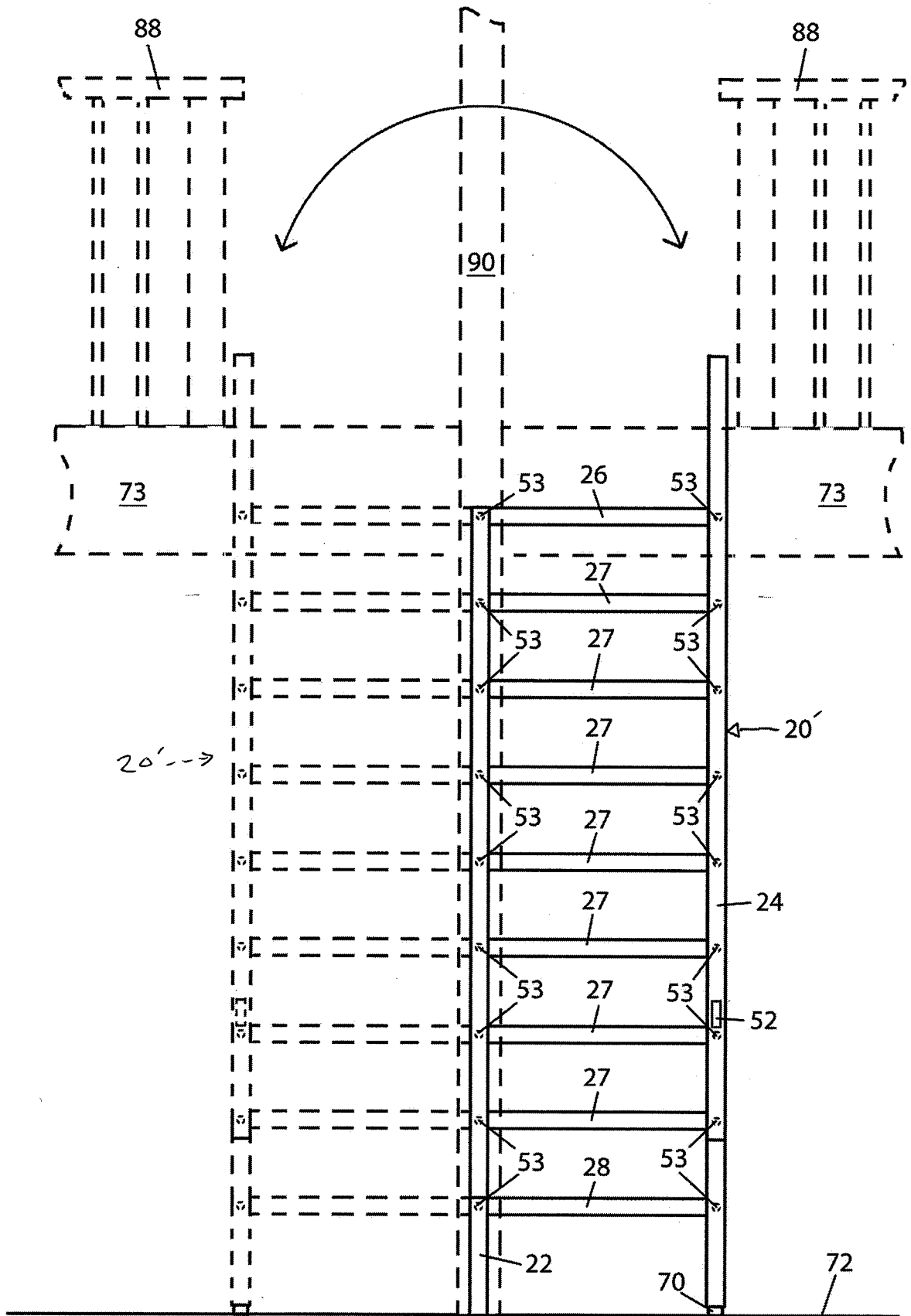

FIG. 21

## INTERNATIONAL SEARCH REPORT

International application No.

PCT/US 2017/022954

A. CLASSIFICATION OF SUBJECT MATTER		<p style="text-align: center;"><i>A47B 57/36 (2006.01)</i> <i>E06C 1/393 (2006.01)</i></p> <p>According to International Patent Classification (IPC) or to both national classification and IPC</p>	
B. FIELDS SEARCHED			
Minimum documentation searched (classification system followed by classification symbols)			
A47B 57/00-57/58, 61/00, 85/00, 85/08, E06C 1/00-1/02, 1/38-1/397			
Documentation searched other than minimum documentation to the extent that such documents are included in the fields searched			
Electronic data base consulted during the international search (name of data base and, where practicable, search terms used)			
PatSearch (RUPTO internal), USPTO, PAJ, Esp@cenet, DWPI, EAPATIS, PATENTSCOPE			
C. DOCUMENTS CONSIDERED TO BE RELEVANT			
Category*	Citation of document, with indication, where appropriate, of the relevant passages	Relevant to claim No.	
Y	US 5085290 A (EDWARD C. GUIRLINGER) 04.02.1992, col. 4, line 18-col. 5, line 57	1-8, 10-16	
A		9, 17	
Y	CN 2264245 Y (XINHUI CITY FURNITURE FACTORY) 08.10.1997, fig. 1	1-8, 10-16	
Y	RU 109495 U1 (KIZHAPKIN VYACHESLAV YURIEVICH) 20.10.2011, fig. 1, sing ref. 3	2	
Y	ZINGER B. I. Razdvizhnye peregorodki, dveri i solntsezaschitnye ustroistva. Moskva, Stroizdat, 1994, p. 71, uzel II, p. 73, uzel I	6, 8	
Y	RU 50778 U1 (ZAKRYTOE AKTSIONERNOE OBSHESTVO "GRAFITNY") 27.01.2006, fig. 1, p. 3, lines 1-8	11	
Y	RU 15163 U1 (OBSHESTVO S OGRANICHENNOI OTVETSTVENNOSTIYU "LIDER-STROI") 27.09.2000, fig. 1, p. 4	10, 12-15	
<input type="checkbox"/> Further documents are listed in the continuation of Box C.		<input type="checkbox"/> See patent family annex.	
* Special categories of cited documents:			
"A"	document defining the general state of the art which is not considered to be of particular relevance	"T"	later document published after the international filing date or priority date and not in conflict with the application but cited to understand the principle or theory underlying the invention
"E"	earlier document but published on or after the international filing date	"X"	document of particular relevance; the claimed invention cannot be considered novel or cannot be considered to involve an inventive step when the document is taken alone
"L"	document which may throw doubts on priority claim(s) or which is cited to establish the publication date of another citation or other special reason (as specified)	"Y"	document of particular relevance; the claimed invention cannot be considered to involve an inventive step when the document is combined with one or more other such documents, such combination being obvious to a person skilled in the art
"O"	document referring to an oral disclosure, use, exhibition or other means	"&"	document member of the same patent family
"P"	document published prior to the international filing date but later than the priority date claimed		
Date of the actual completion of the international search		Date of mailing of the international search report	
24 May 2017 (24.05.2017)		20 July 2017 (20.07.2017)	
Name and mailing address of the ISA/RU: Federal Institute of Industrial Property, Berezhkovskaya nab., 30-1, Moscow, G-59, GSP-3, Russia, 125993 Facsimile No: (8-495) 531-63-18, (8-499) 243-33-37		Authorized officer  A. Bykovsky  Telephone No. 8-499-240-25-91	