

# United States Patent

Fleming et al.

[15] 3,654,377

[45] Apr. 4, 1972

[54] **ELECTRICAL LEADS FOR CRYOGENIC DEVICES**

[72] Inventors: Robert B. Fleming, Scotia; Carl H. Rosner, Schenectady, both of N.Y.

[73] Assignee: General Electric Company

[22] Filed: Dec. 15, 1969

[21] Appl. No.: 885,225

[52] U.S. Cl. ....174/15, 62/54, 62/514

[51] Int. Cl. ....H01b 7/34

[58] Field of Search .....62/54, 514; 174/15; 165/164, 165/185; 338/51, 52

[56] **References Cited**

**UNITED STATES PATENTS**

2,958,021 10/1960 Cornelison et al. ....174/15

3,349,161 10/1967 Latham .....174/15  
3,371,145 2/1968 Camille, Jr. ....174/15

*Primary Examiner*—Meyer Perlin

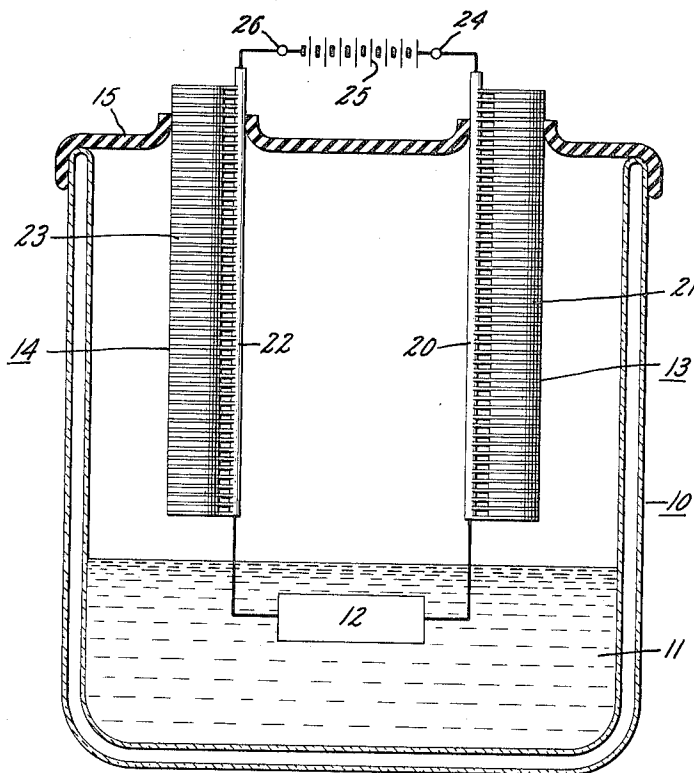
*Assistant Examiner*—Ronald C. Capossela

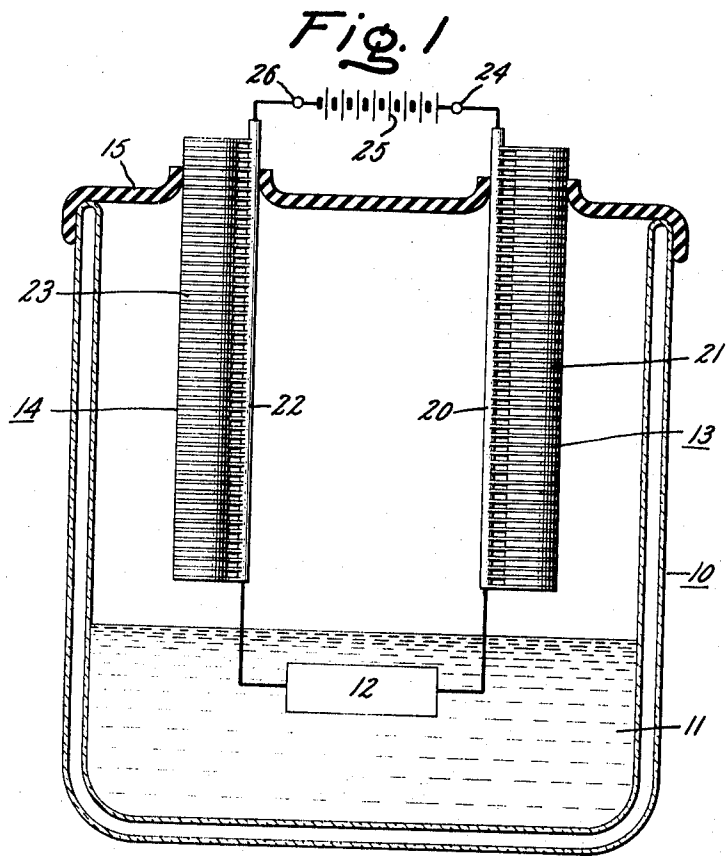
*Attorney*—Paul A. Frank, John F. Ahern, Julius J. Zaskalicky, Frank L. Neuhauser, Oscar B. Waddell and Joseph B. Forman

[57] **ABSTRACT**

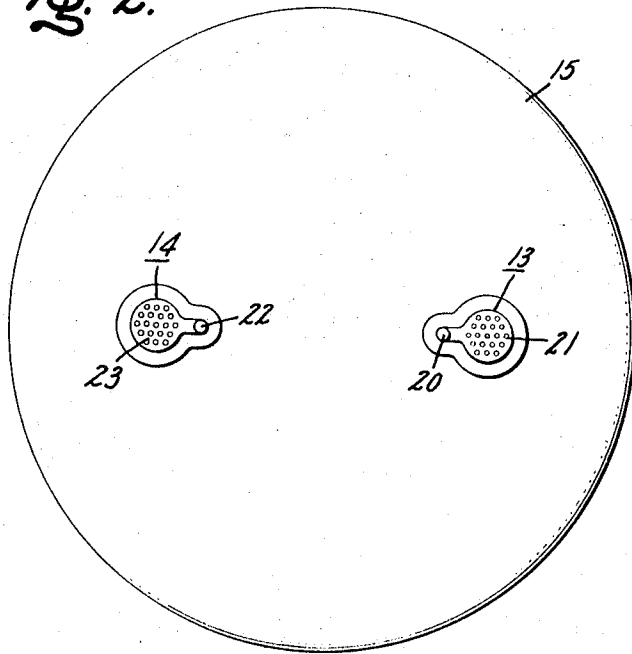
Heat which is conducted into the cryogenic environment of a cryogenic liquid or gas along an electrical lead of a device immersed therein is shunted into a stack of perforated plates, each spaced from adjacent plates by insulating separators, and each of which is conductively connected by a respective tap to the lead. Vapor evaporated from the bath is passed through the plates which absorb the heat that would otherwise pass through the lead into the bath, thereby reducing the boil-off of liquid from the bath.

6 Claims, 3 Drawing Figures

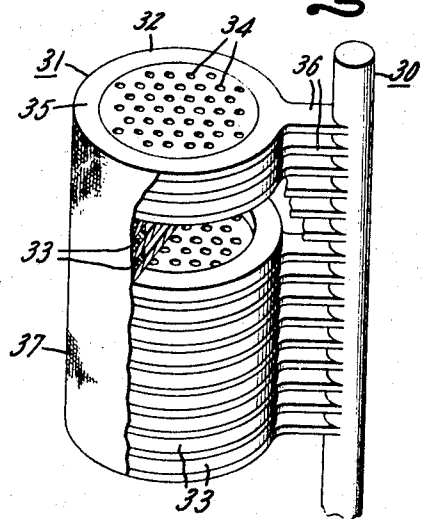




*Fig. 2.*



*Fig. 3.*



Inventors:  
Robert B. Fleming,  
Carl H. Rosner,  
by *Wm. J. P. K. P. K.*  
Their Attorney.

## ELECTRICAL LEADS FOR CRYOGENIC DEVICES

The present invention relates to electrical leads for conducting current from a warm region to a cold region and, more particularly, to such leads for conducting large currents to cryogenic devices immersed in a cryogenic medium.

Liquid helium is used to cool most devices operating near 4°K. In the case of superconducting solenoids, large currents must generally be conducted from a power supply at room temperature to the liquid helium. The current carrying conductors must have a large cross-sectional area in order to avoid resistive losses. However, such large cross-sectional area allows high thermal conduction into the liquid helium. The consequent high rate of helium boil off is wasteful. The boiled off helium vapor possesses a large capacity for cooling. The present invention is directed to means associated with the electrical lead-in conductors to the helium bath to inhibit the boil off of helium and make effective use of the cooling capacity of the boiled off helium.

Accordingly, it is an object of the present invention to provide improvements in electrical current conduction leads of the character described.

Another object of the present invention is to provide a simple and compact lead structure of the character described.

It is another object of the present invention to provide an electrical lead of the character described having high conduction for electrical currents and having low conductivity for heat flow from the warm to the cold end thereof.

It is another object of the present invention to provide a current conducting lead for cryogenic devices which has low resistance to gas flow from one end to the other end thereof.

It is a further object of the present invention to provide a cryogenic lead construction which is highly efficient in the exchange of heat between the electrical conduction portion thereof and the fluid flowing in the heat exchanger portion thereof.

In accordance with an illustrative embodiment of the present invention, there is provided a plurality of high conductivity porous plates and a plurality of low conductivity separators. Each separator is interposed between and in contact with adjacent ones of the plates and each of the separators has an enclosing rim portion. The spacers in the plates are aligned to form a longitudinal channel for the passage of fluid therethrough. The plates are situated adjacent to an elongated electrical lead with the plates being perpendicular to the longitudinal axis of the lead. A plurality of tabs are provided, each tab conductivity connected between a respective plate and an adjacent point on the lead.

The novel features which are believed to be characteristic of the present invention are set forth in the appended claims. The invention itself, however, together with further objects and advantages thereof may best be understood by reference to the following description taken in connection with the accompanying drawings wherein:

FIG. 1 is a side view in section of a dewar flask into which current is conducted through electrical leads in accordance with the present invention.

FIG. 2 is a top view of the dewar flask and leads of FIG. 1.

FIG. 3 is a perspective view of a portion of the lead structure of FIGS. 1 and 2.

Referring now to FIGS. 1 and 2 there is shown a dewar 10 containing a cryogenic liquid 11, such as, for example, liquid helium. Immersed in the cryogenic liquid is an electrically operated device 12 intended to be operated at cryogenic temperatures, that is, the temperature of, for example, liquid helium, hydrogen, neon, nitrogen, argon or oxygen. The electrical device may be a device such as a motor, groscope, coil and the like requiring electrical current for its operation. Also shown are a pair of electrical lead assemblies 13 and 14 in accordance with the present invention. Each of the lead assemblies 13 and 14 are identical in structure and are sealed and supported in an insulating cover 15 for the dewar and extend

from a region inside the dewar adjacent the liquid 11 to a region external or outside the dewar. The electrical lead assembly 13 includes a current conducting portion 20 and a heat exchanger portion 21 conductively connected to the electrical current conducting portion along the length thereof. Similarly, the electrical lead assembly 14 includes an electrical lead portion 22 and a heat exchanger portion 23 conductively connected to the electrical current carrying portion along the length thereof. One terminal of the electrical lead 12 is connected through the electric current conductor portion 20 to one terminal 24 of a source 25 of electrical current, such as a battery, and the other terminal of the lead 12 is connected through the current carrying portion to the other terminal 26 of the source 25.

Reference is now made to FIG. 3 which shows a perspective view of the construction of the lead assemblies 13 and 14. The current carrying portion of each of the electrical lead assemblies 13 and 14 is an elongated electrical lead 30 having a longitudinal axis. The heat exchanger portion 31 of the assemblies 13 and 14 includes a plurality of identical high conductivity porous plates 32 and a plurality of low conductivity separators or spacers 33. The plates may be made of aluminum or copper and the separators or spacers may be made of an insulating material such as a plastic. Each of plates 32 has a central circular portion in which are formed a plurality of small holes or perforations 34 extending from one face of the plate to the opposite face and having a rim or peripheral portion 35 which is nonporous. Each of separators 33 is annular in form and is of a size to bear against the nonporous portions 35 of adjacent plates. Portions 35 are nonporous to provide good heat conductivity therealong. Each separator 33 is interposed between and in contact with the nonporous portions of adjacent ones of the plates 32. Accordingly, the stacking of the plates and separators forms a longitudinal channel having an axis parallel to the normals to the plates. The peripheral or rim portions of the plates 32 are spaced adjacent to the electrical conductor 30 with the axis of the channel parallel to the longitudinal axis of the conductor 30. Conductive tabs 36 are provided on each of the plates connecting a respective conductive peripheral or rim portion of a plate to an adjacent area on the electrical conductor 30. The tabs may be soldered, welded or brazed to the electrical conductor. The plates 32 and the electrical conductor 30 may be made of aluminum or copper. The tabs are provided with sufficient cross-sectional area to provide good heat conduction from the electrical conductor 30 to the heat exchanger 31. The plates 32 and the plastic spacers 33 may be bonded by epoxy to form good seal. If desired, the external surface of the heat exchanger assembly 31 as well as the conductor 30 may be provided with a cloth reinforced plastic coating 37 to provide electrical insulation of the lead assembly. The tabs 36 are made sufficiently flexible to permit differential contraction between the conductor 30 and the stack of plates 32. Preferably, alternate porous or perforated plates in each lead assembly are provided with perforated holes which are misaligned with the perforated holes of an adjacent plate to provide a tortuous path for fluid flowing in the heat exchanger for good heat transfer.

The parallel plate construction of the assembly provides a simple and compact heat exchanger connected to a lead for efficiently utilizing the cooling capacity of cryogenic fluid evaporated from the bath. The assembly of the present invention provides low pressure drop from the vapor inlet to the vapor exit end while at the same time provides a highly effective heat exchanger due to the high surface to volume ratio of the heat exchanger portion and the arrangement of the holes in the plates. The rim portions of the plates are made sufficiently large to enable rapid conduction of heat therethrough. The circular geometry of the assembly provides minimal external surface area in relation to channel volume to provide efficient conduction of heat from the electrical conductor to the heat exchanger channel.

We intend by the appended claims to cover all modifications that fall within the true spirit and scope of our invention.

3

4

What we claim as new and desire to secure by Letters Patent of the United States is:

1. In combination,  
 an elongated electrical lead having a longitudinal axis,  
 a plurality of high conductivity porous plates,  
 a plurality of low conductivity separators, each separator interposed between and in contact with adjacent ones of said plates, each of said plates having an enclosing rim portion, said separators and said plates being aligned to form a longitudinal channel for the passage of fluid therethrough,  
 said plates being situated adjacent to said lead with the said plates being perpendicular to the longitudinal axis of said lead, and  
 means for conductively connecting each of said plates to said lead.

- 2. The combination of claim 1 in which said connecting means includes a plurality of tabs, each tab conductively connected between a respective plate and an adjacent point on said lead.
- 3. The combination of claim 2 in which said porous plates are plates having a multiplicity of holes with parallel axes.
- 4. The combination of claim 3 in which the holes in one plate are nonaligned with the axes of the holes in an adjacent plate.
- 5. The combination of claim 1 in which each of said separators is annular in outline and in which each of said plates is circular in outline.
- 6. The combination of claim 1 in which the region of each of said plates included between the adjacent separators is non-porous.

\* \* \* \* \*

20

25

30

35

40

45

50

55

60

65

70

75