

(19)  
(12)

(KR)  
(B1)

(51) 。 Int. Cl. <sup>6</sup>  
H04B 7/216

(45)  
(11)  
(24)

2002 07 26  
10 - 0345977  
2002 07 12

(21) 10 - 1999 - 0019163  
(22) 1999 05 27

(65) 1999 - 0088591  
(43) 1999 12 27

(30) 98 - 147358 1998 05 28 (JP)

(73) ( )  
5 - 7 - 1

(72) 5 7 - 1 ( )

(74)  
:

(54)

CDMA

(a) 1 2 가 ,  
; (b) 가 ; (c) -  
2 ; (d) 1 가 ,  
2 가 ; (e) 2 가  
가 가 ; (f) (c) 가 ; (g)  
가 (f)

1

2

3

4

5

6

\*

\*

2, 102: RF

3, 103:

4, 104:

5, 6, 105, 106:

7, 107:

8, 108:

9, 109:

10, 110:

(CDMA)

CDMA

CDMA

, 2

)

( narrow band payload)

(

(

)가

(recover)

( , )

(SIR)

(quotient)

CDMA

SIR (despread) CDMA (cellular) (BER)  
 SIR (fluctuation) (fading), (shadowing), (handoff)  
 BER SIR (open loop)  
 - (near - far) 가 가  
 (closed loop) SIR  
 ( , 1dB) 가 SIR ( , 1dB)  
 가 BER BER 가 가 SIR BER  
 가 SIR

5

(S10) (S11) (S21)  
 (S20) (S22) (preamble)  
 가 (S23) (acknowledgement) (S12) (S13)  
 (S14)

1 CDMA

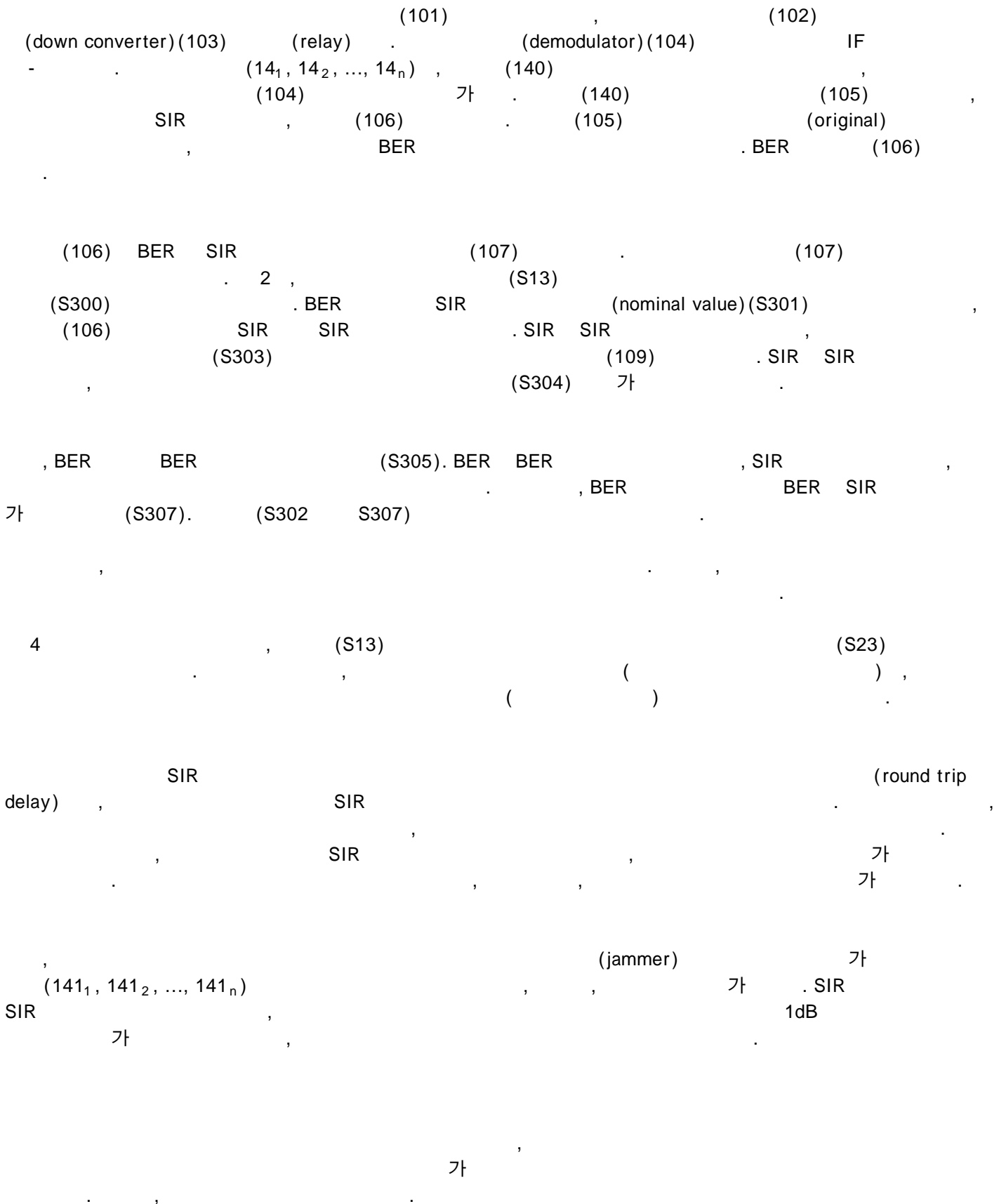

,  
CDMA

(a) 1 2 - - ;

(b) 가 ;

(c) - - , (a) - - 2  
(a) 1 , (a) 2 ;

(d) (c) - - 2 (c) 1 , 가 ;

(e) (c) - - 2 (c) 1 , 가 가 ;

(f) (c) 가 (d) , (c) 가 ;

(g) 가 (f) .

,  
CDMA

(a) 1 2 - - ;

(b) 가 ;

(c) - - , (a) - - 2  
(a) 1 , (a) 2 ;

(d) (c) - - 2 (c) 1 , ;

(e) (c) - - 2 (c) 1 , 가 가 ;

(f) (c) 가 (d) , (c) 가 ;

(g) 가 (f) , .

,  
CDMA

(a) 1 2 - - ;

(b) 가 ;

(c) (a) 1 , (a) 2 ;

(d) (c) 1 가 , ;

(e) (c) 2 가 가 ;

(f) (c) 가 (d) , (c) 가 ;

(g) 가 (f) .

, CDMA

(a) 1 2 - - ;

(b) 가 ;

(c) (a) 1 , (a) 2 ;

(d) (c) 1 가 , ;

(e) (c) 2 가 가 ;

(f) (c) 가 (d) , (c) 가 ;

(g) 가 (f) ,

(b), (c), (d) 가 0.1 dB

(g)

(h) 1 2 - - 가 ;

- (i) - - , - -
- (h) 1 ;
- (j) - - (i) 1 , ;
- (k) - - (i) 1 , 가 ;
- (l) (j) 가 (k) , (h) 2 가 ;
- (m) 가 (l) 2 , 1 가 ; (b) ;
- (n) 가 (l) 2 , 1 ; (b) .

가

0,1 dB SIR 가 , 가 .

3 CDMA (1) (2) (3) (4) IF - (41<sub>1</sub>, 41<sub>2</sub>, ..., 4 (4) (5) SIR (6) (5) BER (6) BER (6) SIR BER (6) SIR BER (7) (9)

(9), (up - converted) (10), (8), (1)

4 5 ,

(S10) 5 (S11) 5  
 (S13) (S11) (S12) (S100)  
 (4)가 (S101).  
 (7) 0.1 dB 가  
 (S102). 가(increment) +1 dB 가 (decrement)  
 -1 dB 가 11 가 9 , 20  
 2 dB 가 , 가  
 (fluctuation)

(S21) 가 (S23) (S20),  
 가 (S23)

(41<sub>1</sub>, 41<sub>2</sub>, ..., 41<sub>n</sub>) (4) (S14)

4 (6) SIR BE  
 R , BER . SIR ,  
 0.1 dB 가 (S102). 가 ( 가 ) ( 가가 0.1 dB )  
 ) 가 , 가

SIR SIR (S103), 가 0.1dB 가 ,  
 , SIR SIR 가 (S104).  
 (S106), 가 ,  
 (disabled) ( ) BER (S107). (S100 S107)  
 가 , SIR SIR (S103).



6 (S104) (S204) SIR (6) SIR 6  
0.1 dB

10

가 .[br/]

가가

가

가

(57)

1.

CDMA

(a) 1 2 - - ;

(b) 가 ;

(c) (a) 1 , (a) 2 ;

(d) (c) 2 , (c) 1 가 ;

(e) (c) 2 , (c) 1 가 가 ;

(f) (c) (d) , (preamble) 가 (c) 가 ;

(g) 가 (f) , CDMA .

2.

CDMA

- (a) 1 2 - - ;
- (b) 가 ;
- (c) (a) 1 , (a) 2 ;
- (d) (c) 2 (c) 1 , ;
- (e) (c) 2 (c) 1 가 , 가 ;
- (f) (c) 가 (d) , (c) 가 ;
- (g) 가 (f) , CDMA .

3.

CDMA

- (a) 1 2 - - ;
- (b) 가 ;
- (c) (a) 1 , (a) 2 ;
- (d) (c) 2 (c) 1 가 , ;
- (e) (c) 2 (c) 1 가 , 가 ;
- (f) (c) 가 (d) , (c) 가 ;

(g) 가 (f)  
, CDMA .

4.

CDMA ,

, ,

(a) 1 2 - - ;

(b) 가 ;

(c) (a) 1 , (a) 2 ;

(d) (c) 2 (c) 1 , ;

(e) (c) 2 (c) 1 가 , 가 ;

(f) (c) 가 (d) , (c) 가 ;

(g) 가 (f)  
, CDMA .

5.

1 4 ,  
(b), (c), (d) 가 가 0.1 dB , CD  
MA .

6.

1 4 ,  
(g) :

(h) 1 2 - - 가 ;

(i) (h) 1 ;

(j) - - (i) 1 , ;

- (k) - - (i) 1 , 가 ;
  - (l) (j) , (k) , 가 (h) 2 가 ;
  - (m) 가 , 가 (b) ; (l) 2 , 1
  - (n) , 가 (b) (l) 2 , 1 , CDMA .
- 7.
- 5 ,
- (g) :
- (h) 1 2 - - 가 ;
  - (i) (h) 1 - - , - - ;
  - (j) - - (i) 1 , ;
  - (k) - - (i) 1 , 가 ;
  - (l) (j) , (k) , 가 (h) 2 가 ;
  - (m) 가 , 가 (b) ; (l) 2 , 1
  - (n) , 가 (b) (l) 2 , 1 , CDMA .

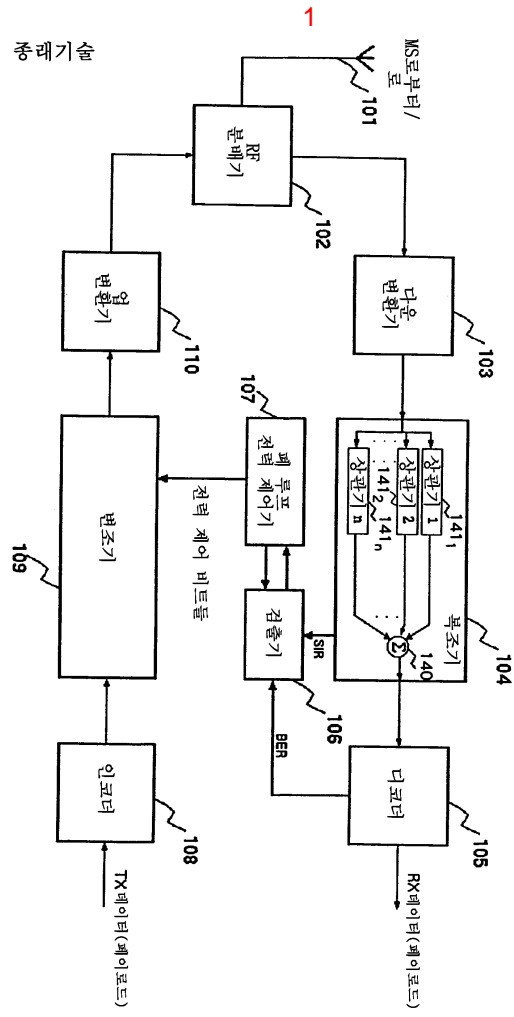

2

종래기술

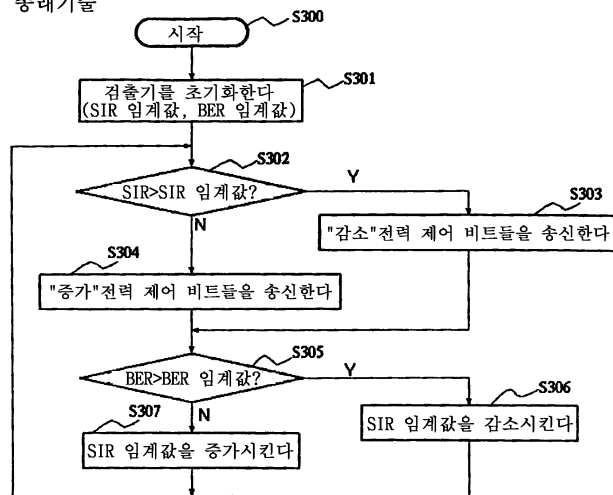

3

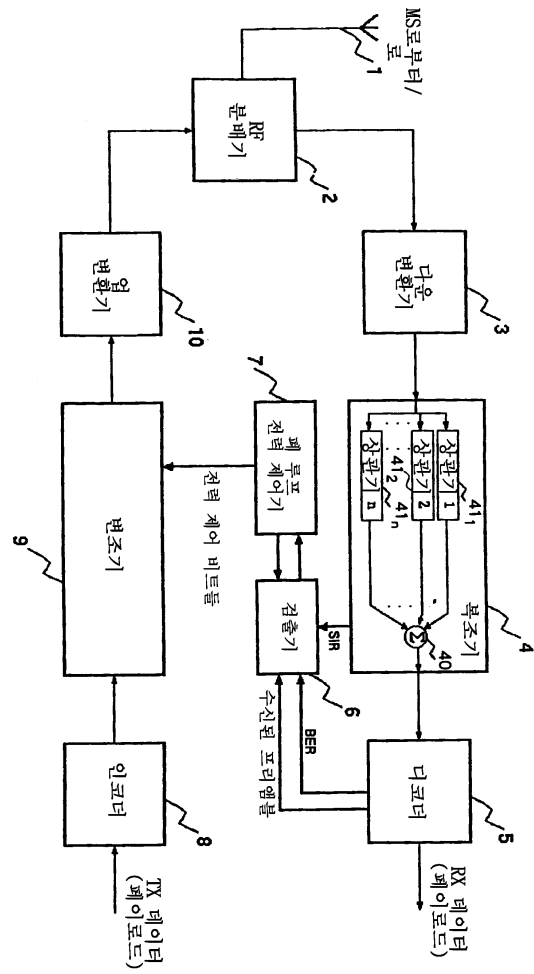

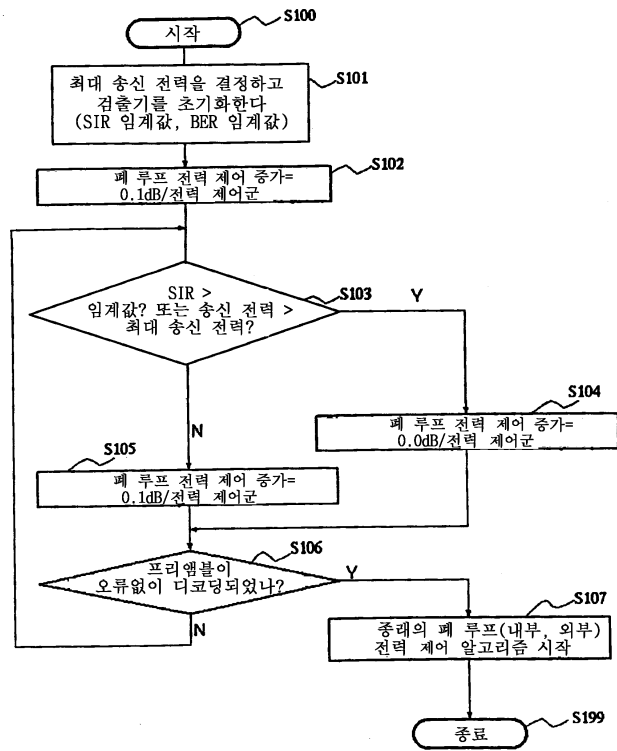



5

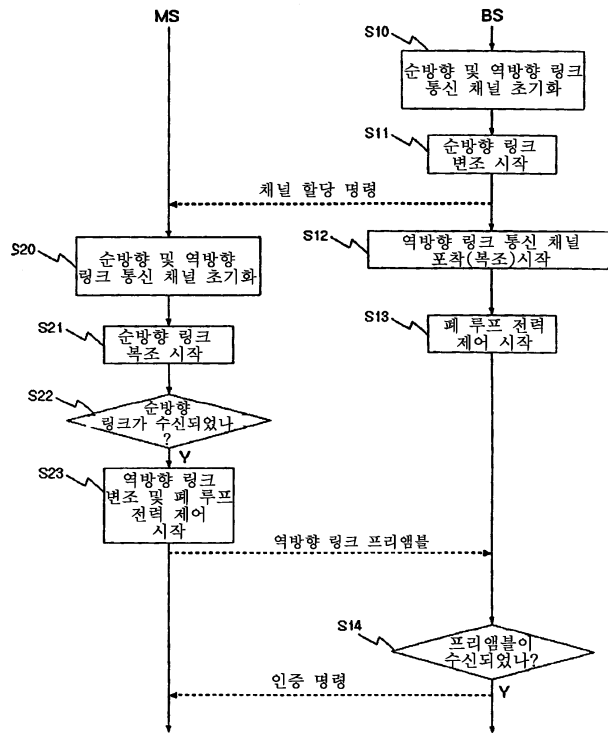

6

