



T. CRANEY.  
DRAINAGE BIN AND CHUTE.

No. 522,406.

Patented July 3, 1894.

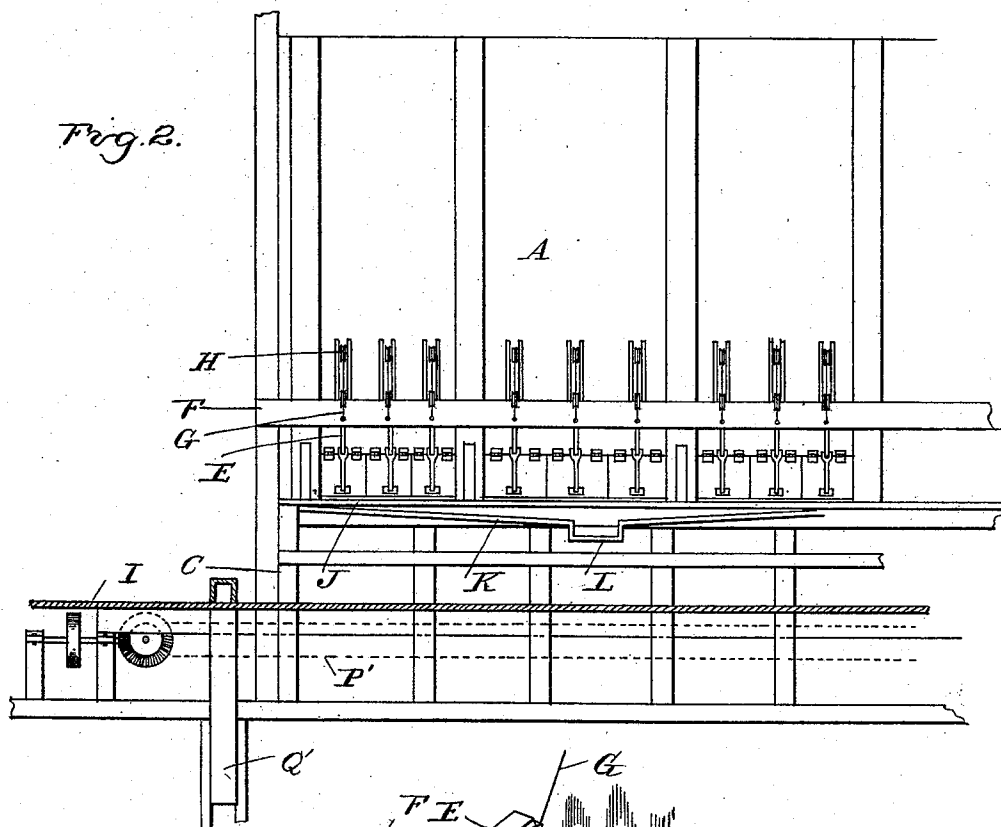
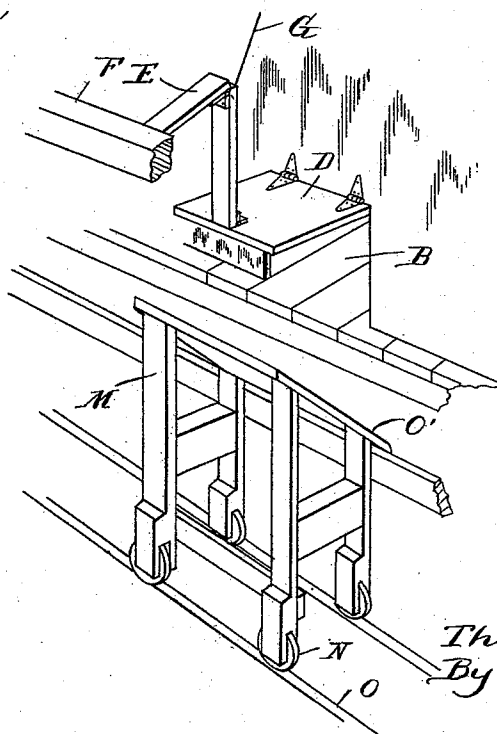

Fig. 3.



Witnesses  
*O. L. Hobbes*  
*W. M. Maguire*

Inventor  
*Thomas Craney*  
 By *W. M. Maguire*  
*Atty.*

# UNITED STATES PATENT OFFICE.

THOMAS CRANEY, OF BAY CITY, MICHIGAN.

## DRAINAGE-BIN AND CHUTE.

SPECIFICATION forming part of Letters Patent No. 522,406, dated July 3, 1894.

Application filed October 9, 1893. Serial No. 437,620. (No model.)

*To all whom it may concern:*

— Be it known that I, THOMAS CRANEY, a citizen of the United States, residing at Bay City, in the county of Bay and State of Michigan, have invented certain new and useful Improvements in Drainage-Bins and Chutes, of which the following is a specification, reference being had therein to the accompanying drawings.

The invention consists, first, in the peculiar construction of a drainage bin and especially in the construction of the door and its locking devices; second, in the drainage therefor, and third, in the means for delivering the salt from the bin into the elevator, all as more fully hereinafter described.

In the drawings, Figure 1 is a vertical, central section through a bin and chute embodying my invention. Fig. 2 is a front elevation of a series of such bins and Fig. 3 is a perspective view showing the movable truck.

A are a series of bins arranged side by side, and B are the inclined bottoms thereof, the bin being supported upon a suitable sub-structure C. At the lower front edge I provide each bin with a door D hinged on the outside so as to open outwardly. This door is controlled by means of a brace E formed of two substantially like sections united at their adjacent ends by a rule joint, the inner end of the brace being hinged to the door and its outer end is hinged to the beam F against which the inward pressure on the door is exerted to hold it closed. At or near the joint in the brace E is connected the strap or rope G which passes over sheaves H and in proximity to the operator on the floor I, so that by drawing down on this rope, the brace will be centrally broken upon its hinge, and the door D open outwardly as shown in dotted lines in Fig. 1. Sufficient space is left beneath the edge of the door D and the upper face of the bottom B to allow any moisture in the salt to drain out upon the forward extension J of the bottom, from which it drains into the trough K, which inclines from each end toward the middle and communicates there with the rear-

wardly inclined trough L. The salt may be allowed to remain in these bins until the large volume of water contained therein when it comes from the evaporator is drawn off. It is then ready to be discharged by opening the door D in the manner described, allowing the salt to pass out through the door by gravity, or by the use of a scraper if necessary.

M is a truck supported on wheels N and run on suitable rails O on the floor, in front of these bins. This truck is provided on its top with the inclined deflecting board O' which inclines toward the bins discharging beneath the same.

When any bin is desired to be emptied, this truck is moved along opposite the same and as the salt falls out it will strike this inclined deflecting board and be carried beneath the bins into the hopper P, at the bottom of which is the conveyer P', shown in Fig. 2. This conveyer conveys the salt to the end of the bins where it discharges into the elevator Q', by means of which the salt is carried to the drier, or the salt if desired may be carried to the storage bins directly.

When one bin is emptied, the door will be closed and it may be re-filled, the truck may be moved along to the next bin which may be emptied in the same manner, and thus with a single chute or deflector, I am enabled, not only to economize room but to obtain a satisfactory feed from all the bins.

What I claim as my invention is—

The combination of a series of adjacent stationary salt bins, having discharging doors at their front, a truck having an inclined top extending down to a point below the bins and arranged to run across the front of the bins, and hoppers beneath the bins in line with the lower edge of the top of the truck, substantially as described.

In testimony whereof I affix my signature in presence of two witnesses.

THOMAS CRANEY.

Witnesses:

M. B. O'DOHERTY,  
OTTO F. BARTHEL.