

H. A. ENGELS.
Hot Air Furnace.

No. 7,082.

Patented Feb. 12, 1850.

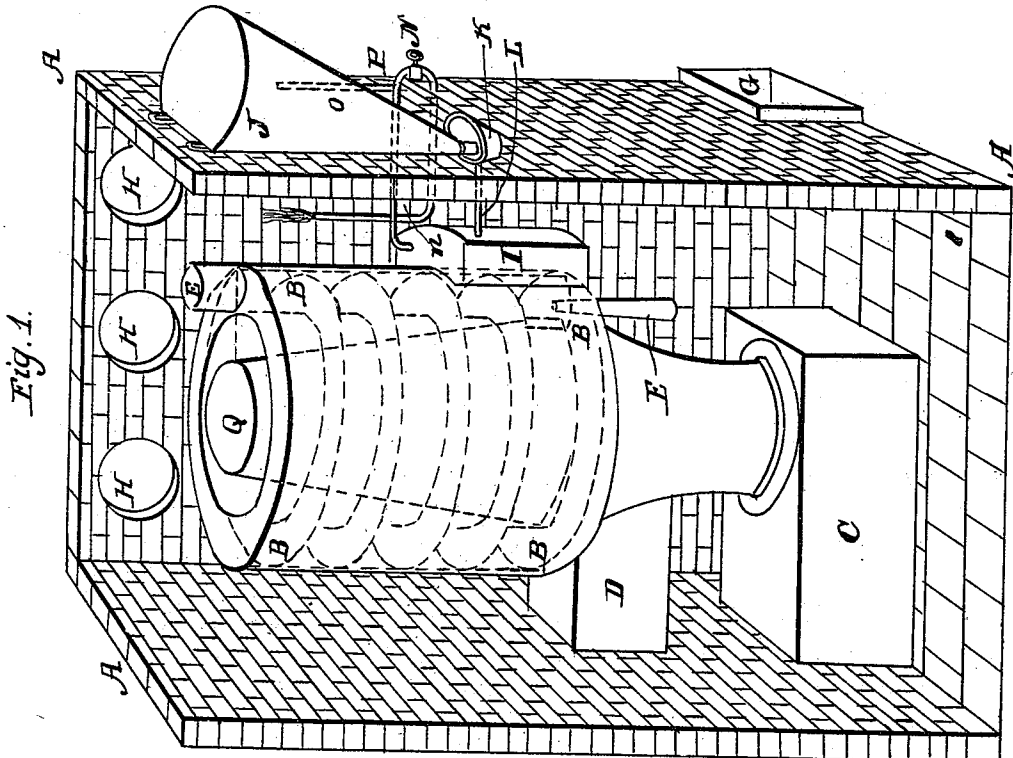
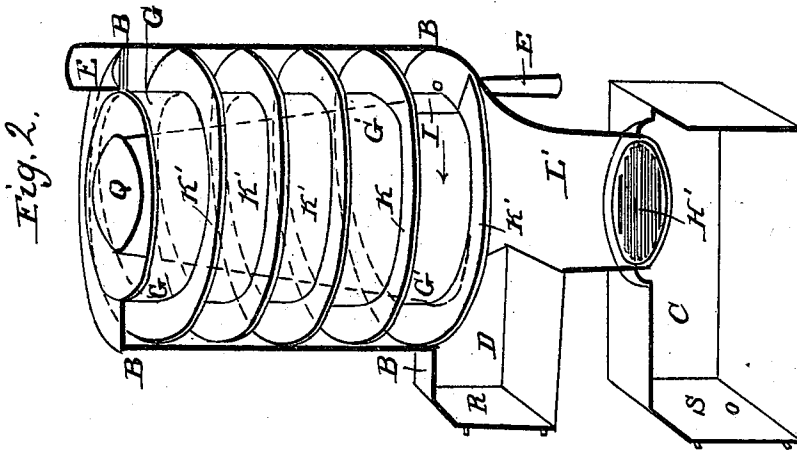

Inventor:
Henry Joseph Engels.

UNITED STATES PATENT OFFICE.

HENRY A. ENGELS, OF CINCINNATI, OHIO.

AIR-HEATING FURNACE.

Specification of Letters Patent No. 7,082, dated February 12, 1850.

To all whom it may concern:

Be it known that I, HENRY ADOLPH ENGELS, of Cincinnati, Hamilton county, Ohio, have invented new and useful improvements in air-heating and steam-infusing apparatus for warming and keeping sufficiently moist the atmosphere in apartments; and I do hereby declare the following to be a full, clear, and exact description of the same, reference being had to the annexed drawings, making part of this specification, in which drawings—

Figure I represents the apparatus in perspective, the rear or front wall of the hot-air chamber being left out for the better exhibition of the apparatus and Fig. II represents the furnace in a partially sectional view vertically, so as clearly to exhibit the spiral flue.

The nature of my invention consists in arranging a pair of concentric cylinders over a furnace so that the flue can be made to pass spirally between the cylinders; thus making the inside face of the inner cylinder and the outside face of the outside cylinder, radiating surfaces; and in addition to this attaching the base of a cone-shaped drum or chamber to and inside the lower end of the inner concentric cylinder (or in any other suitable way) so as to obtain a radiating surface from the outside of the drum, which is thus made to form the roof of the furnace, the whole fixtures thus being made to furnish the most extensive radiating surface within the smallest possible compass. This arrangement also enables a small air-chamber to furnish a comparatively large amount of heated air.

Another feature of my invention consists in combining with the furnace a steam infuser whereby the heated air in the chamber surrounding the furnace is supplied with an adequate degree of moisture, so arranged as to be regulated at pleasure and thus obviating the unhealthy and disagreeable effects due to air, which, in the process of being heated, is rendered too dry for being breathed and therefore unfit for domestic or other apartments.

In the drawings (A) Fig. I is the hot

air-chamber built of bricks or other substance.

(B) is the outside cylinder forming the outside of spiral flue.

(G'), Fig. II, is the inside cylinder forming the inside of the spiral flue.

(C) is the ash-pit with its door (S).

(D) is the feeder with its door (R).

(E) is the smoke-pipe.

(F) is the tube to admit air and prevent thereby any injury to the spiral flue from intensity of heat.

(G) is the entrance for cold air to the chamber (A); (H), outlets for heated air, through suitable conductors, to any desired place; (H'), Fig. II, grate of furnace; (I), boiler attached to outside cylinder (B) for generating steam; (J), reservoir for water for feeding boiler and placed outside of air chamber (A); (K), receiver of said feed water.

The reservoir is a vertical half of a cone with the apex downward and opening in the receiver. The water is therefore sustained therein by the atmosphere; the receiver and reservoir acting like a sort of fountain inkstand, too well known to need description.

(L) is the supply pipe leading from reservoir (K) to boiler (I).

(M) is the steam pipe arranged so as to communicate with a safety valve (P) in an escape pipe (O) outside the chamber (A) and then passing through a regulating faucet (N) back again into chamber (A) where it discharges such a continuous amount of steam as may be desired or is sufficient to infuse proper moisture throughout the heated air.

(Q) is the conical shaped drum for the roof of the furnace (L'), Fig. II.

(I'), Fig. II, is the opening from the furnace into the flue.

(K'), Fig. II, is the floor of the spiral flue.

The dotted lines indicate the position of the several parts. The arrow indicates the course of the flame and smoke.

Having thus fully clearly and exactly described the nature construction and opera-

tion of my improvements in air heating and steam infusing apparatus for warming and keeping moist the atmosphere in apartments what I claim therein as new and desirable to secure by Letters Patent is—

Constructing a furnace for heating air, with a spiral flue passing up between concentric cylinders when this is combined with a conical roof to the furnace within

the inner concentric cylinder thus obtaining the most expensive radiating surface within the least space and in the most compact and simple form.

HENRY ADOLPH ENGELS.

Witnesses:

D. T. SNELBAKER,
C. H. VAN SEGGERN.