

⑫ **EUROPEAN PATENT SPECIFICATION**

- ⑬ Date of publication of patent specification: **28.12.88** ⑮ Int. Cl.⁴: **E 06 B 3/08**
⑰ Application number: **85901989.5**
⑲ Date of filing: **29.03.85**
⑳ International application number:
PCT/DK85/00030
㉑ International publication number:
WO 86/05831 09.10.86 Gazette 86/22

⑥④ **A WINDOW CONSTRUCTION.**

- | | |
|--|--|
| ④③ Date of publication of application:
22.04.87 Bulletin 87/17 | ⑦③ Proprietor: JOHANSEN, Jorgen Skoubo
Radalsvej 19
DK-4040 Jyllinge (DK) |
| ④⑤ Publication of the grant of the patent:
28.12.88 Bulletin 88/52 | ⑦② Inventor: JOHANSEN, Jorgen Skoubo
Radalsvej 19
DK-4040 Jyllinge (DK) |
| ⑧④ Designated Contracting States:
DE GB LU NL | ⑦④ Representative: Jabbusch, Wolfgang, Dr.
Elisabethstrasse 6
D-2900 Oldenburg (DE) |
| ⑤⑧ References cited:
CH-A- 496 157
GB-A-2 093 104
US-A-4 187 657 | |

EP 0 218 580 B1

Note: Within nine months from the publication of the mention of the grant of the European patent, any person may give notice to the European Patent Office of opposition to the European patent granted. Notice of opposition shall be filed in a written reasoned statement. It shall not be deemed to have been filed until the opposition fee has been paid. (Art. 99(1) European patent convention).

Description

The invention relates to a window construction comprising a main frame or parts of a gap in a wall, which serve as a frame, as well as a framed glass pane capable of closely abutting said frame or parts and being either fixedly mounted so as to be opened, the framing of the pane comprising a corner joined none-supportive sash extending in a plane substantially parallel to and outside the glass pane, as well as clips or interconnected clamp strips of metal forming a substantially U-shaped gripping member and pressed over the edges of the pane, said clips or clamp strips pressing the sash towards the edge zone of one side of the pane continuously along all edges of the pane, whereby a sealing and/or pressure relief, is established at the surface of the pane by inserting a resilient, sealing intermediary layer such as a resilient joint filler or a resilient joint tape between the edge zone of the pane and the sash.

US—A—4 187 657 discloses a window construction of the above type. As a result of the development glass panes have grown still heavier partly because the desires are directed to greater windows and partly—and perhaps mainly—because it is now often a question of windows of several layers of glass with air therebetween, i.e. the so-called insulating panes. The increased weight and thickness of the glass panes involve increased and different requirements to the dimensions, the type, and the profiling of the framing material, which interalia has caused very heavy glass framings.

The window construction according to the invention is characterised in that sash is of insulating material such as wood or plastics and is arranged at that side of the pane which is facing the main frame, the sash thus being capable of abutting said main frame.

The characteristic features of the above framing of the pane are consequently that the sash is retained closely to the edge zone of the pane at the side of the glass pane facing the frame by means of the clips or the clamp strips and further that the sash can form a sealing abutment against the frame. The sash need not absorb forces from the weight of the pane and can thus be rather slender. When the framing of the pane is to be mounted on the pane, the sash is placed on the pane while simultaneously covering the edge zone of one side of the pane, optionally the sealing, resilient intermediary layer being placed between the sash and the pane. Subsequently, the sash is pressed into abutment against the pane by means of the clips or the clamp strips, the U-shaped cross section of the latter being pressed over the edge of the pane so as to grip over the edge of the pane and portions of the sash. As a result, these parts are kept assembled. In order to prevent the clips or the clamp strips from destroying the pane, a sealing resilient intermediary layer may, as mentioned, be inserted between the pane and the clips/the clamp strips. This intermediary

layer may for instance be made of plastics or rubber.

In this manner the parts of the framing absorbing the forces from the weight of the pane and optionally transferring said forces to functional fittings are positively positioned either on the cold or the warm side of the abutment of the sash against the frame. As a result, the problems of the cold bridges, if any, are avoided, said cold bridges often arising in connection with attempts to manufacturing pane framings of metal. Furthermore, an almost complete freedom as to production and design is obtained because the sealing abutment between the frame and the sash in principle is independent of the structure of the metal members and of their possible interconnection. By "clip" should be understood a clamp strip or clamp strip-like member, which is short or relatively short.

A simple framing of the pane is according to the invention provided by producing a sash of wood shaped and dimensioned in such a manner that it can cover 15—20 mm of the edge zone of the pane and may have a circumferential groove parallel to the plane of the pane and formed in the radially outward edge surface of the sash. The sash is placed on the pane, a resilient sealing mass being applied in advance between the sash and the glass. Subsequently, U-profiles are inserted, for instance steel profiles bent of 0.05—1 mm thick steel pliable sheeting, into the circumferential groove of the sash in such a manner that the U-profiles grip over the edge zone of the pane relative to the opposite side of the sash. The U-profiles are mutually fixed in the corners by means of fittings or through a direct joining by means of rivets or screws. Finally, plastic or rubber strips are inserted between the U-profiles and the glass on the side of the pane opposite the sash. The framing of the pane has thus been completely established. The completion of the above concerns a strengthening or a particularly aesthetic design which, however, is beyond the scope of the present application.

According to a particular embodiment the sash is made of L-shaped PVC-profile, said L-profile being assembled through corner weldings to form the sash. The welding together of the L-profiles is carried out in such a manner that one outer side of the L-profiles abuts the edge zone of the glass pane and the other side faces the centre of the pane. In this manner one leg of the L-profiles extends from the plane of the pane at a short distance from the edges of the pane. As a result, it is possible to form a labyrinth seal through the cooperation of the glass pane with the frame because abutment can be established both at the end of the projecting profile portion and on the clamp strip facing backwards relative thereto and abutting the leg of the L-profile which abuts the edge zone of the pane. Such an embodiment is particularly suited for inward windows as the mounting of a closing device allowing an outward opening of the window would present problems.

The invention will be described below with reference to the accompanying drawing, in which

Fig. 1 is a sectional view of a portion of a first embodiment of the window according to the invention, the pane framing being particularly simple.

Fig. 2 is a sectional view through another embodiment of the window where the sash is an extruded profile for labyrinthic sealing, and

Fig. 3 is a horizontal sectional view through a portion of a third embodiment of the window, where the sash is secured by screwing onto a profiled body of metal.

Fig. 1 shows how in a particularly simple manner an insulating pane can be framed according to the invention, a sash 2 being mounted against the edge zone of the insulating pane 1. This sash is clamped towards the pane by means of clip or clamp strips 3, the clamp strip gripping into a groove 4 and extending to the opposite side of the edge 5 of the insulating pane, whereby a pressure relieving profile 6 is inserted between the pane and the clamp strip. Furthermore, a resilient sealing 7 is established in the zone between the sash 2 and the glass 1. The frame of the window is indicated through a dotted line 8.

Fig. 2 illustrates in principle the same framing of the pane as Fig. 1, but with the alteration that the stop frame is made of extruded profiled bodies 9 of an L-cross section and for instance made of PVC. These profiled bodies are shaped so as together with the clamp strips 10 extending from corner to corner of the glass pane to form a labyrinthic sealing partly through stops against a frame portion opposite the end 11 of the L partly through sealing against a sealing strip 12 at the clamp strip 10. The cross section of the frame has been indicated through a dotted line 13.

Fig. 3 illustrates a horizontal sectional view through a further framing of a pane provided with clamp strips. The sash 20 is here pressed against the edge zone of the pane by means of screws 15 partly extending into the sash 20 and partly through a web 16 of a metal clamp strip 16. This metal clamp strip extends along and abuts the "opposite" edge zone of the glass pane 17, a rubber relieving member 18 being inserted between the metal strip 16 and the glass pane 17. The frame has been shown with a dotted line 19.

Claims

1. A window construction comprising a main frame (8, 13, 19) or parts of a gap in a wall, which serve as a frame, as well as a frame glass pane (1) capable of closely abutting said frame or parts and being either fixedly mounted or mounted so as to be opened, the framing of the pane comprising a corner joined non-supportive sash (2, 9, 20) extending in a plane substantially parallel to and outside the glass pane, as well as clips or interconnected clamp strips (3, 10, 16) of metal forming a substantially U-shaped gripping member and pressed over the edges of the pane, said clips or clamp strips pressing the sash towards the

edge zone of one side of the pane continuously along all edges of the pane, whereby a sealing and/or pressure relief, is established at the surface of the pane by inserting a resilient, sealing intermediary layer (7) such as a resilient joint filler or a resilient joint tape between the edge zone of the pane and the sash, characterised in that sash (2, 9, 20) is of insulating material such as wood or plastics and is arranged at that side of the pane (1) which is facing the main frame (8, 13, 19), the sash thus being capable of abutting said main frame.

2. A window construction as claimed in claim 1, characterised in that the clamp strips (3, 10) are made of bent pliable sheeting.

3. A window construction as claimed in claim 1 or 2, characterised in that the clamp strips (3, 10) extend from corner to corner of the glass pane (1) and are interconnected through corner fittings.

4. A window construction as claimed in claim 1 or 2, characterised in that two parallel clamp strips are provided, and that an outer dimension of the U-shaped cross section of one pair of clamp strips corresponds to an inner dimension of the U-shaped cross section of the second pair of clamp strips in such a manner that the clamp strips of the first pair of clamp strips are insertable in the clamp strips of the second pair of clamp strips adjacent the corners of the window construction and are interlocked by means of screws or rivets drilled through the cooperating four free webs of the clamp strips in each corner.

5. A window construction as claimed in claim 1, characterised in that the screws are mounted in a web (16) of a clamp strip which extends along and abuts the edge zone of the side of the glass pane (1) opposite the sash (20), the head of said screws forming together with the shank of each screw and the said web the U-shaped gripping cross section for pressing the sash (20) inwards towards the edge zone of the glass pane (1), whereby the sash projects slightly radially outside the glass pane (1).

6. A window construction as claimed in one or more of the preceding claims 1—4, characterised in that the sash (2) is provided with a radially outward groove (4) cooperating with the clamp strips (3) or the clips.

7. A window construction as claimed in one or more of the preceding claims 1—6, characterised in that the sash (9) is of a substantially L-shaped cross section.

Patentansprüche

1. Fenster-Konstruktion, die einen Hauptrahmen (8, 13, 19) oder Teile eines Loches in einer Wand, die als Rahmen dienen, sowie eine gerahmte Glasscheibe (1), welche geeignet ist, eng an den genannten Rahmen oder die Teile anzustoßen und entweder fest montiert ist oder derart montiert ist, um geöffnet werden zu können, umfaßt, wobei die Umrahmung der Scheibe einen über Eck verbundenen nicht-tragenden Flügelrahmen (2, 9, 20), der sich in einer Ebene im wesentlichen parallel zu und außerhalb der Glas-

scheibe erstreckt, umfaßt, sowie Klammern oder untereinander verbundene Klemmleisten (3, 10, 16) aus Metall, die ein im wesentlichen U-förmiges Klemmglied bilden, und auf den Rand der Scheibe gedrückt, drücken die genannten Klammern oder Klemmleisten den Flügelrahmen gegen den Randbereich einer Seite der Scheibe, fortlaufend entlang aller Ränder der Scheibe, wobei eine Abdichtung und/oder eine Druckentlastung an der Oberfläche der Scheibe verwirklicht wird, durch Einsetzen einer elastischen Abdichtungs-Zwischenlage (7), wie z.B. eine elastische Dichtungsmasse oder ein elastisches Dichtungsband zwischen der Randzone der Scheibe und dem Flügelrahmen, dadurch gekennzeichnet, daß der Flügelrahmen (2, 9, 20) aus isolierendem Material, wie z.B. Holz oder Kunststoff, ist und an der Seite der Scheibe (1) angeordnet ist, die dem Hauptrahmen (8, 13, 19) zugewandt ist, so daß der Flügelrahmen geeignet ist, eng an den genannten Hauptrahmen anzustoßen.

2. Fenster-Konstruktion nach Anspruch 1, dadurch gekennzeichnet, daß die Klemmleisten (3, 10) aus gebogenem, biegbaren Blech gefertigt sind.

3. Fenster-Konstruktion nach Anspruch 1 oder 2, dadurch gekennzeichnet, daß die Klemmleisten (3, 10) von Ecke zu Ecke der Glasscheibe (1) ausgedehnt sind und durch Eckverbindungsstücke untereinander verbunden sind.

4. Fenster-Konstruktion nach Anspruch 1 oder 2, dadurch gekennzeichnet, daß zwei parallele Klemmleisten vorgesehen sind und daß eine äußere Abmessung des U-förmigen Querschnittes eines Paares von Klemmleisten einer inneren Abmessung des U-förmigen Querschnittes des zweiten Paares von Klemmleisten entspricht, derart, daß die Klemmleisten des ersten Paares von Klemmleisten in die Klemmleisten des zweiten Paares von Klemmleisten den Ecken der Fenster-Konstruktion benachbart einsetzbar sind und durch Mittel von Schrauben oder Nieten, die in jeder Ecke durch die zusammenwirkenden vier freien Schenkel der Klemmleisten gebohrt sind, zusammengesetzt sind.

5. Fenster-Konstruktion nach Anspruch 1, dadurch gekennzeichnet, daß Schrauben in einem Schenkel (16) einer Klemmleiste montiert sind, welche sich entlang des Randbereiches der dem Flügelrahmen (20) entgegengesetzten Seite der Glasscheibe (1) erstreckt und an diese angrenzt, und daß der Kopf der genannten Schrauben zusammen mit dem Schaft jeder Schraube und dem genannten Schenkel den U-förmigen Greif-Querschnitt zum Drücken des Flügelrahmens (20) einwärts gegen den Randbereich der Glasscheibe (1) bildet, wobei der Flügelrahmen leicht an der Außenseite der Glasscheibe (1) radial hervorsteht.

6. Fenster-Konstruktion nach einem oder mehreren der vorhergehenden Ansprüche 1 bis 4, dadurch gekennzeichnet, daß der Flügelrahmen (2) mit einem radialen äußeren Einschnitt (4) versehen ist, der mit den Klemmleisten (3) oder den Klammern zusammenwirkt.

7. Fenster-Konstruktion nach einem oder mehreren der vorhergehenden Ansprüche 1 bis 6, dadurch gekennzeichnet, daß der Flügelrahmen (9) einen im wesentlichen L-förmigen Querschnitt aufweist.

Revendications

1. Structure de fenêtre comprenant un cadre principal (8, 13, 19) ou des parties d'un vide dans un mur qui servent de cadre, ainsi qu'un carreau de vitre encadré (1) capable de buter étroitement contre ledit cadre ou les dites parties et étant soit monté de façon fixe soit monté de façon à s'ouvrir, l'encadrement de la vitre comprenant un châssis de fenêtre (2, 9, 20) ne formant pas support et à jonction aux angles qui s'étend dans un plan pratiquement parallèle à la vitre et à l'extérieur de celle-ci ainsi que des brides ou des bandes de serrage en métal (3, 10, 16) reliées entre elles formant un organe de préhension pratiquement en U et pressées sur les bords de la vitre, les dites brides ou bandes de serrage pressant le châssis vers la zone de bordure d'une face de la vitre de façon continue le long de tous les bords de la vitre de sorte qu'une étanchéité et/ou un soulagement de la pression est réalisé à la surface de la vitre par insertion d'une couche de jonction intermédiaire élastique (7) telle qu'une garniture de joint élastique entre la zone du bord de la vitre et le châssis, caractérisée en ce que le châssis (2, 9, 20) est en matière isolante telle que du bois ou des matières plastiques et est disposé sur la face de la vitre (1) ui est du côté du cadré principal (8, 13, 19), le châssis étant ainsi capable de buter contre ledit cadre principal.

2. Structure de fenêtre selon la revendication 1, caractérisée en ce que les bandes de serrage (3, 10) sont faites de tôle pliable coudée.

3. Structure de fenêtre selon la revendication 1 ou 2, caractérisée en ce que les bandes de serrage (3, 10) s'étendent d'un angle à un autre de la vitre de verre (1) et sont reliées entre elles par des éléments d'angle.

4. Structure de fenêtre selon la revendication 1 ou 2, caractérisée en ce que deux bandes de serrage parallèles sont prévues et en ce qu'une dimension extérieure de l'élément transversal en U d'une paire de bandes de serrage correspond à une dimension intérieure de l'élément transversal en U de la seconde paire de bandes de serrage de telle manière que les bandes de serrage de la première paire de bandes de serrage peuvent s'insérer dans les bandes de serrage de la seconde paire de bandes de serrage adjacente aux angles de la structure de fenêtre et sont verrouillées au moyen de vis ou de rivets engagés à travers les quatre branches libres des bandes de serrage à chaque angle.

5. Structure de fenêtre selon la revendication 1, caractérisée en ce que des vis sont montées dans une branche (16) d'une bande de serrage qui s'étend le long de la zone marginale du côté de la vitre de verre (1) opposé au châssis (20) et bute contre cette zone, la tête desdites vis formant

avec la tige de chaque vis et ladite branche l'élément transversal de serrage en U pour presser le châssis (20) vers l'intérieur vers la zone de bordure de la vitre de verre (1), de sorte que le châssis avance légèrement en direction radiale à l'extérieur de la vitre de verre (1).

6. Structure de fenêtre selon l'une ou plusieurs des revendications précédentes 1—4, caractérisée

en ce que le châssis (2) présente une rainure radiale extérieure (4) coopérant avec les bandes de serrage (3) ou les brides.

7. Structure de fenêtre selon l'une ou plusieurs des revendications précédentes 1—6, caractérisée en ce que le châssis (9) a en coupe une forme pratiquement en L.

5

10

15

20

25

30

35

40

45

50

55

60

65

5

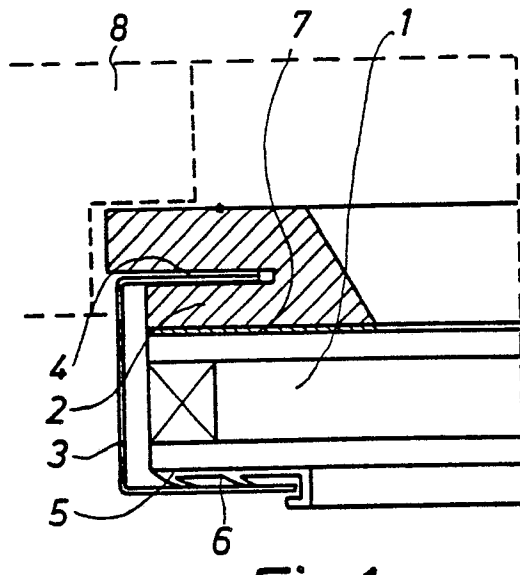

Fig.1

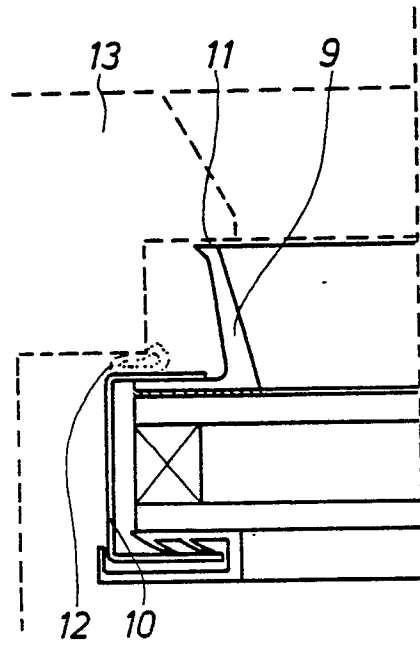

Fig.2

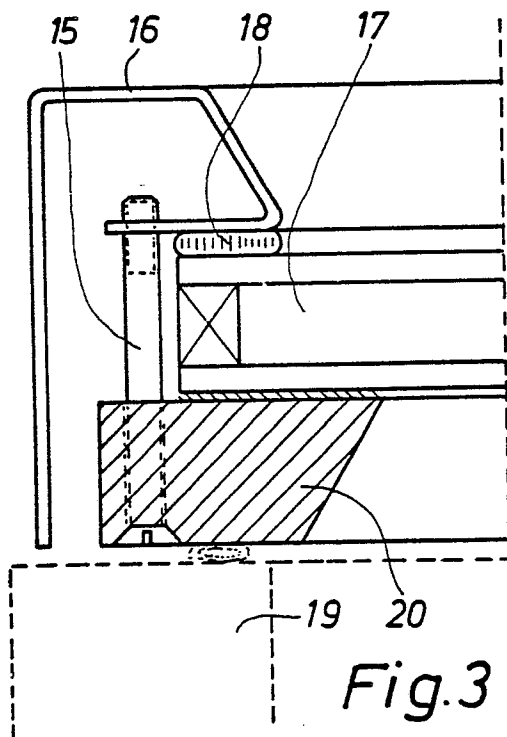

Fig.3