



(11) **EP 1 122 810 B1**

(12) **EUROPEAN PATENT SPECIFICATION**

(45) Date of publication and mention of the grant of the patent:
22.02.2012 Bulletin 2012/08

(51) Int Cl.:
H01Q 1/36^(2006.01) H01Q 1/38^(2006.01)
H01Q 1/24^(2006.01)

(21) Application number: **00117315.2**

(22) Date of filing: **18.08.2000**

(54) **Antenna device**

Antennenvorrichtung

Dispositif d'antenne

(84) Designated Contracting States:
DE FI FR GB SE

(30) Priority: **31.01.2000 JP 2000027222**

(43) Date of publication of application:
08.08.2001 Bulletin 2001/32

(73) Proprietor: **MITSUBISHI MATERIALS CORPORATION**
Chiyoda-ku,
Tokyo (JP)

(72) Inventors:

- **Hirose, Eiichiro,**
Mitsubishi Materials Corp.
Chichibu-gun,
Saitama-ken (JP)
- **Toyoda, Akikazu,**
Mitsubishi Materials Corp.
Chichibu-gun,
Saitama-ken (JP)
- **Go, Yoshiomi,**
Mitsubishi Materials Corp.
Chichibu-gun,
Saitama-ken (JP)

- **Sakai, Shinji,**
Mitsubishi Materials Corp.
Chichibu-gun,
Saitama-ken (JP)
- **Tanidokoro, Hiroaki,**
Mitsubishi Materials Corp.
Chichibu-gun,
Saitama-ken (JP)
- **Kitahara, Naoto,**
Mitsubishi Materials Corp.
Chichibu-gun,
Saitama-ken (JP)

(74) Representative: **HOFFMANN EITLE**
Patent- und Rechtsanwälte
Arabellastraße 4
81925 München (DE)

(56) References cited:

EP-A- 0 658 907 EP-A- 0 766 340
EP-A- 0 825 668 EP-A- 0 944 128
DE-A- 1 439 264 GB-A- 784 807
US-A- 2 781 514 US-A- 2 866 197
US-A- 5 977 931

EP 1 122 810 B1

Note: Within nine months of the publication of the mention of the grant of the European patent in the European Patent Bulletin, any person may give notice to the European Patent Office of opposition to that patent, in accordance with the Implementing Regulations. Notice of opposition shall not be deemed to have been filed until the opposition fee has been paid. (Art. 99(1) European Patent Convention).

Description

BACKGROUND OF THE INVENTION

5 1. Field of the Invention

[0001] The present invention relates to an antenna device to be used for portable communication sets.

10 2. Description of the Related Art

[0002] Although a linear antenna such as a pole antenna or a rod antenna has been used in communication sets such as a portable phone, such antenna hinders the communication set to be small size because the antenna has been attached at outside of the case of the communication set, besides causing a risk of breakage, deformation and deterioration of characteristics by suffering external mechanical forces acting on the antenna. In addition, the antenna is not preferable with respect to the packaging cost since a number of components are required for packaging the antenna via coaxial cables and connectors.

[0003] For solving the problems as described above, Japanese Unexamined Patent Application Publication No. 9-64627 proposes a compact antenna capable of surface-packaging on a circuit board as shown in FIG. 26. A helical antenna is formed within a ceramic substrate **30** by making use of a technique for forming a multi-layer ceramic substrate. A conductor line **31** is formed on each ceramic layer, and the conductor lines on different ceramic layers are connected one another via through holes **32** in which a conductive material is filled to form a helical conductor as a whole.

[0004] A ceramic antenna including a helical radiation conductor is assembled by laminating the ceramic layers. A terminal **33** for feeding electricity to the helical conductor is provided on the side face of the substrate **30**.

[0005] However, since the laminated ceramic sheets are fired after forming a conductor line on each ceramic sheet before firing, the conductor line should be designed by taking shrinkage by firing into consideration. A highly rigid process control is also required in order to restrict the shrinkage ratio within a prescribed range, thus making it difficult to reduce the production cost.

[0006] Suppose that all the conductor lines are formed on the surface of the already fired ceramic sheet, but conductor patterns should be nevertheless formed on at least four faces of a ceramic block having flat surfaces by a method capable of fine control of the conductor pattern such as a printing method, also preventing the production cost from being reduced.

[0007] An antenna device according to the preamble of claim 1 is known from US-A-5,977,931.

SUMMARY OF THE INVENTION

35 **[0008]** Accordingly, the object of the present invention in view of the circumstances as hitherto described is to provide an antenna device designed to reduce the production cost.

[0009] The present invention, for attaining the object above, provides an antenna device comprising: a substrate comprising at least one of a dielectric material or a magnetic material having upper and lower faces as well as a pair of side faces on which convex portions and concave portions are alternately formed; and a helical conductor layer formed on the upper and lower faces, and on the concave portion or convex portion on a pair of the side faces of the substrate so as to spirally surround the entire substrate; and the further features recited in claim 1.

[0010] The antenna device according to the present invention comprises a helical antenna in which a helical emission conductor is formed on the surface of the ceramic substrate, and the conductor layer on the upper and lower faces of the substrate can be formed by printing. Electrodes can be formed only on the convex portions by a high speed coating method such as a dip method or using a roll coater for forming the conductive layer on the convex portions on the side face. Using the roll coater enables superior mass-productivity to the printing method to be attained for forming the electrode particularly on the convex portion. It is also an advantage of forming the electrode on the convex portion that solders hardly form solder bridges when the solder is used for connecting the electrode on the convex portion in mounting the antenna device. When the conductive layer is formed in the concave portion on the side face, on the other hand, it can be formed by filling a conductor material in through holes to be described hereinafter, also offering an advantage that the solder bridge is hardly formed. Accordingly, the present invention can make mass-production easy besides enabling the production cost to be largely reduced.

[0011] The surface mountable type antenna can be also readily manufactured since the side face convex portions and concave portions themselves on which conductor lines are formed can be utilized as terminal electrodes.

55 **[0012]** The device comprises: a power feed electrode for feeding electricity to the helical conductor layer comprising a portion located at one end of the plural portions sequentially disposed with a given distance apart on one side face of the substrate, the plural portions constituting the helical conductor layer; an earth electrode for grounding the helical conductor layer formed at an adjoining position to the power feed electrode with a given distance apart to the power

feed electrode on the same side face of the substrate as the side face on which the power feed electrode is formed; and a connection conductor layer extending from the earth electrode for connecting the earth electrode to the power feed electrode in collaboration with a part of the helical conductor layer by allowing the connection conductor layer to connect to the helical conductor layer via the upper face of the substrate.

5

BRIEF DESCRIPTION OF THE DRAWINGS

[0013]

10 FIG. 1 shows a perspective view of the antenna device according to an example (not part of the present invention).
 FIG. 2 shows an intermediate step of the manufacturing process of the antenna device shown in FIG. 1;
 FIG. 3A shows an intermediate step of the manufacturing process of the antenna device shown in FIG. 1;
 FIG. 3B shows an intermediate step of the manufacturing process of the antenna device shown in FIG. 1;
 FIG. 4 shows an intermediate step of the manufacturing process of the antenna device shown in FIG. 1;
 15 FIG. 5 shows an intermediate step of the manufacturing process of the antenna device shown in FIG. 1;
 FIG. 6 shows a perspective view of the antenna device according to an example (not part of the present invention).
 FIG. 7 shows an intermediate step of the manufacturing process of the antenna device shown in FIG. 2;
 FIG. 8 shows an intermediate step of the manufacturing process of the antenna device shown in FIG. 2;
 FIG. 9A shows an intermediate step of the manufacturing process of the antenna device shown in FIG. 2;
 20 FIG. 9B shows an intermediate step of the manufacturing process of the antenna device shown in FIG. 2;
 FIG. 10 shows an intermediate step of the manufacturing process of the antenna device shown in FIG. 2;
 FIG. 11 illustrates a method for evaluating the antenna device;
 FIG. 12 shows a graph showing the relation between the reflection loss and frequency characteristics of the antenna device;
 25 FIG. 13 shows an emission pattern on the XY-plane in FIG. 11;
 FIG. 14 shows a perspective view of an antenna device according to the present invention;
 FIG. 15 shows an intermediate step of the manufacturing process of the antenna device shown in FIG. 14;
 FIG. 16 shows an intermediate step of the manufacturing process of the antenna device shown in FIG. 14;
 FIG. 17 shows an intermediate step of the manufacturing process of the antenna device shown in FIG. 14;
 30 FIG. 18A shows an intermediate step of the manufacturing process of the antenna device shown in FIG. 14;
 FIG. 18B shows an intermediate step of the manufacturing process of the antenna device shown in FIG. 14;
 FIG. 19 shows an intermediate step of the manufacturing process of the antenna device shown in FIG. 14;
 FIG. 20 shows a perspective view of the antenna device according to an example (not part of the present invention);
 FIG. 21 shows a perspective view of the antenna device according to an example (not part of the present invention);
 35 FIG. 22 shows a perspective view of another antenna device;
 FIG. 23 illustrates the method for evaluating the antenna device;
 FIG. 24 shows an assembly of the antenna device according to an example;
 FIG. 25 shows an assembly of the antenna device according to an example; and
 FIG. 26 illustrates a conventional compact antenna capable of surface packaging on a circuit board.

40

DESCRIPTION OF THE PREFERRED EMBODIMENT

[0014] FIG. 1 shows a perspective view of the antenna device according to an example.

45 **[0015]** The substrate **2** of the antenna device **1** comprises an upper face **21** and a lower face **22**, and a pair of the side faces **23** on which concave portions **231** and convex portions **232** are alternately formed. Conductor layer **3** for connecting corresponding convex portions **232** one another on a pair of the side faces **23** are formed on the upper face **21** of the substrate **2**. Conductor layers **4** for connecting the convex portions **232** on a pair of the side faces **23**, one on the side face and the other on the opposite side face that is shifted by one pitch from the former one, are formed on the lower face **22** of the substrate **2**. Conductor layers **5** are also formed on the convex portions **232** of a pair of the side faces **23**, and these conductor layers **3**, **4** and **5** serve as a helical conductor layer for surrounding the substrate **2** as a whole.

50 **[0016]** The preferable substrate **2** has a stable specific dielectric constant (ϵ_r) or a stable specific magnetic permeability (μ_r) with a low loss and a small temperature coefficient (τ) of the resonance frequency. An alumina based ceramic ($\epsilon_r = 8.5$, $Q = 1000$ and $\tau = 38$ ppm/ $^{\circ}$ C at 2 GHz) was used in this example. The preferable conductor comprises a low resistance conductor such as copper, silver and gold. A silver-platinum paste (QS-171 made by Dupont CO.) was used in this example.

55 **[0017]** The method for manufacturing the antenna device **1** will be described hereinafter with reference to FIGS. 2 to 5 showing the manufacturing process of the antenna device **1** shown in FIG. 1. An alumina substrate **9** shown in FIG.

2 is firstly prepared. Snap lines **10** are provided on the alumina substrate **9** so as to be able to divide the substrate into a desired size in the steps hereinafter. Through holes **11** are also provided at desired sites on the snap lines. The snap lines **10** were disposed by a distance of 5 mm apart along the vertical direction and by a distance of 10 mm apart along the transverse direction, and the through holes **11** with a diameter of 0.8 mm were disposed by a distance of 2 mm apart on the snap lines along the transverse direction on the alumina substrate with a width of 50 mm, a length of 50 mm and a thickness of 1 mm.

[0018] Subsequently, conductor patterns **12** and **13** as shown in FIG. 3A and FIG. 3B were formed on the upper face **91** and lower face **92**, respectively, of the alumina substrate **9**. The patterns were formed by screen-printing a conductive paste to subject the pattern to firing at 850°C after drying.

[0019] The alumina substrate **9** after forming the upper and lower conductors were divided along the snap lines on which the through holes had been formed as shown in FIG. 4. After previously spreading a conductor paste **15** to a thickness of about 0.2 mm on a flat plate **14** such as a glass plate using a squeezer, convex portions formed on the alumina substrate by the through holes were dipped into the conductor paste **15** to coat only the tips of the convex portions with the conductor paste **15** followed by drying and firing.

[0020] As shown in FIG. 5, an antenna device **1** was finally obtained by dividing the flat plate into minimum units along the snap line. A lot of the antennas having such construction as described above can be manufactured at a time to enable a cost reduction effect to be exhibited.

[0021] FIG. 6 shows a perspective view of the antenna device according to another example.

[0022] The substrate **2** of this antenna device **1** comprises an upper face **21**, a lower face **22** and a pair of side faces **23** on which concave portions **231** and convex portions **232** are alternately formed as in the substrate **2** of the antenna device **1** shown in FIG. 1. However, the conductor layer of the antenna device **1** shown in FIG. 6 is a little different from the conductor layer of the antenna device shown in FIG. 1. In the antenna device **1** shown in FIG. 6, the conductor layer **3** for connecting between a pair of the concave portions **231** with each other is formed on the upper face **21**, the conductor layer **4** for connecting one concave portion to the other concave portion that is shifted by one pitch from the former one is formed on the back face **22**, and the conductor layer **5** is formed on the inner wall face of the concave portion, thereby forming a helical conductor layer with the conductor layers **3**, **4** and **5**. However, these conductor layers **3**, **4** and **5** also serve as a helical conductor layer for surrounding the substrate **2** as a whole, as in the antenna device shown in FIG. 1.

[0023] The preferable substrate **2** of the antenna device **1** shown in FIG. 6 also has a stable specific dielectric constant (ϵ_r) or a stable specific magnetic permeability (μ_r) with a low loss and a small temperature coefficient (τ_r) of the resonance frequency, as in the antenna device shown in FIG. 1. An alumina based ceramic ($\epsilon_r = 8.5$, $Q = 1000$ and $\tau_r = 38$ ppm/°C at 2 GHz) was used in this embodiment. The preferable conductor comprises a low resistance conductor such as copper, silver and gold. A silver-platinum paste (QS-171 made by Dupont CO.) was used in this example.

[0024] The method for manufacturing the antenna device shown in FIG. 6 will be described hereinafter with reference to FIGS. 7 to 10 showing the manufacturing process of the antenna device **1** shown in FIG. 6. Snap lines **10** are provided on the alumina substrate **9** as shown in FIG. 7 so as to be able to divide the substrate into a desired size in the steps hereinafter. Through holes **11** are also provided at desired sites on the snap lines. The snap lines **10** were disposed by a distance of 5 mm apart along the vertical direction and by a distance of 10 mm apart along the transverse direction, and the through holes **11** with a diameter of 0.8 mm were disposed by a distance of 2 mm apart on the snap lines along the transverse direction on the alumina substrate **9** with a width of 50 mm, a length of 50 mm and a thickness of 1 mm.

[0025] After filling the conductor paste into the through holes on the alumina substrate **9** by printing as shown in FIG. 8, the paste was fired at 850°C after drying to complete through hole conductors **14**.

[0026] Subsequently, conductor patterns **12** and **13** were formed by printing as shown in FIG. 9A and FIG. 9B, respectively, on the upper face **91** and lower face **92** of the alumina substrate **9**.

[0027] The antenna device **1** is finally obtained by dividing the substrate into minimum units along the snap lines **10** as shown in FIG. 10. A lot of the antennae having such construction as described above can be manufactured at a time to enable a cost reduction effect to be exhibited.

[0028] While two examples have been described herein, a layer having the same quality as the alumina substrate **9** may be formed on the conductor layer formed on the alumina substrate before or after dividing the alumina substrate **9** in either of these examples, thereby allowing an antenna for use in the same transmission and reception band to be more compacted.

[0029] The performance of the antenna device manufactured as described above will be described hereinafter. The antenna device shown in FIG. 1 will be explained herein.

[0030] The antenna device **1** was mounted on a evaluation substrate with a length of 25 mm, a width of 50 mm and a thickness of 0.8 mm as shown in FIG. 11. A strip line **17** and a ground face **18** are formed on the surface and back face of the insulation substrate **16** in this evaluation substrate. Electricity is supplied from a SMA connector **19** at one end to the antenna device **1** at the other end via the strip line **17**.

[0031] The relation between the reflection loss and frequency characteristics is shown in FIG. 12. The resonance frequency was 2448 MHz and the reflection loss was -6 dB or below at a band width of 133MHz.

[0032] The radiation pattern on the XY plane in FIG. 11 is shown in FIG. 13. Radiation gain turned out to be approximately omnidirectional in this face, while the maximum gain was -0.7 dBi and the minimum gain was -2.3 dBi.

[0033] While the antenna device having the construction as shown in FIG. 6 has been evaluated, the result was almost identical to the evaluation result of the antenna device having the construction as shown in FIG. 1. Accordingly, explanations thereof will be omitted herein.

[0034] FIG. 14 shows a perspective view of an antenna device according to an embodiment of the present invention.

[0035] The substrate **2** of the antenna device **1** comprises an upper face **21** and a lower face **22**, and a pair of side faces **23** on which concave portions **231** and convex portions **232** are alternately formed. Conductor layers **3** for connecting between corresponding two convex portions **232** on a pair of the side faces **23** are formed on the upper face **21** of the substrate **2**. Conductor layers **4** for connecting the convex portions **232** on a pair of the side faces **23**, one on the side face and the other on the opposite side face that is shifted by one pitch from the former one, are formed on the lower face **22** of the substrate **2**. Conductor layers **5** are also formed on the concave portions **232** on a pair of side faces **23**, and these conductor layers **3**, **4** and **5** serve as a helical conductor layer spirally surrounding the substrate **2** as a whole.

[0036] The conductor layer at the most end of the conductor layers constituting the helical conductor layer, spirally surrounding the substrate as a whole, of the conductor layers **5** on one side face **23a** of a pair of the side faces **23** serves as a power feed electrode **5a**. A ground electrode **6a** is formed at the adjoining position to the power feed electrode **5a** with a given distance apart from the helical conductor layer. A connection conductor **6b** connecting the helical conductor layer to the ground electrode **6a** via the upper face of the substrate is additionally formed.

[0037] It is preferable that the preferable substrate **2** has a stable specific dielectric constant (ϵ_r) or a stable specific magnetic permeability (μ_r) with a low loss and a small temperature coefficient (τ) of the resonance frequency. An alumina based ceramic ($\epsilon_r = 8.5$, $Q = 1000$ and $\tau = 38$ ppm/ $^{\circ}\text{C}$ at 2 GHz) was used in this embodiment. The preferable conductor comprises a low resistance conductor such as copper, silver and gold. A silver-platinum paste (QS-171 made by Dupont CO.) was used in this example.

[0038] The method for manufacturing the antenna device **1** will be described hereinafter with reference to FIGS. 15 to 19 showing the method for manufacturing the antenna device **1** shown in FIG. 14. An alumina substrate **9** as shown in FIG. 15 is firstly prepared. Snap lines **10** are provided on this alumina substrate **9** so that it can be divided into a desired size in the subsequent steps. Through holes **11** are also provided on the desired sites on the snap line. The snap lines **10** were disposed by a distance of 5 mm apart along the vertical direction and by a distance of 10 mm apart along the transverse direction, and the through holes **11** with a diameter of 0.8 mm were disposed by a distance of 2 mm apart on the snap lines along the vertical direction on the alumina substrate **9** with a width of 50 mm, a length of 50 mm and a thickness of 1 mm.

[0039] Conductor patterns **12** and **13** were then formed on the upper face **91** and lower face **92**, respectively, on the alumina substrate **9** as shown in FIGS. 16 and 17. A conductor paste was screen-printed for forming the conductor patterns, followed by firing at 850 $^{\circ}\text{C}$ after drying.

[0040] The alumina substrate **9** after forming the upper and lower conductors was divided along the snap lines on which the through holes had been formed as shown in FIG. 18. After previously spreading a conductor paste **15** to a thickness of about 0.2 mm on a flat plate **14** such as a glass plate using a squeezer, convex portions formed on the alumina substrate by the through holes were dipped into the conductor paste **15** to coat only the tips of the convex portions with the conductor paste **15** followed by drying and firing.

[0041] An antenna device **1** was finally obtained by dividing the substrate into minimum units along the snap lines. A lot of the antennas having such construction as described above can be manufactured at a time to enable a cost reduction effect to be exhibited.

[0042] FIG. 20 shows a perspective view of the antenna device according to an example not part of the present invention. The difference of this example from the embodiment shown in FIG. 14 will be described hereinafter. While the ground electrode **6a** is connected to the conductor layer spirally surrounding the substrate as a whole via the connection conductor **6b** on the upper face of the substrate in the third embodiment shown in FIG. 14, the ground electrode **6a** is connected to the conductor layer via the connection conductor **6b** on the opposed side face **23b** to the side face **23a** on which the ground electrode **6a** is formed in the example shown in FIG. 20.

[0043] FIG. 21 shows a perspective view of an antenna device according to an example.

[0044] In the example shown in FIG. 21, a conductor layer at the most end of the conductor layers constituting the helical conductor layer, spirally surrounding the substrate as a whole, of plural conductor layers **5** disposed on one side face **23a** serves as a ground electrode **5b**, which also serves as a ground conductor, and the conductor layer adjoining to the ground electrode serves as a power feed electrode **5a**.

[0045] FIG. 22 shows a perspective view on another example of the antenna device.

[0046] While the antenna device itself shown in FIG. 22 is provided as a comparative example of the antenna device, it also serves as an antenna device for constituting an assembly of the antenna device to be described hereinafter.

[0047] In the antenna device shown in FIG. 22, the ground electrode **6a** is connected to the helical conductor layer surrounding the substrate as a whole with a connection conductor **6b**, via the upper face of the substrate, via the side

face **23b** at the opposite side to the side face **23a** on which the ground electrode **6a** is formed, and via the lower face of the substrate.

[0048] The performance of the antenna device manufactured as described above will be described hereinafter.

[0049] The antenna device **1** was mounted on an evaluation substrate with a width of 50 mm, a length of 25 mm and a thickness of 0.8 mm as shown in FIG. 23. A strip line **17** is formed on the surface, and a ground face **18** is formed on the back face of the insulation substrate **16**, and electricity is supplied from a SAM connector **19** through the strip line **17** to the antenna device **1** mounted on the other end of the substrate.

[0050] TABLE 1 shows the results measured as described above. The "3σ value of dispersion" denotes the 3σ value of dispersion of the resonance frequencies when a number of the antenna devices having the same specification one another are manufactured.

TABLE 1 DISPERSION OF RESONANCE FREQUENCY FROM CENTRAL FREQUENCY 2.45 GHz

CONTACT POSITION	3σ VALUE OF DISPERSION
EXAMPLE 1: UPPER FACE OF ANTENNA (FIG. 14)	± 30MHz
EXAMPLE 2: SIDE FACE (FIG. 20)	± 60MHz
EXAMPLE 3: TERMINAL ALSO SERVES AS CONTACT POSITION 21)	± 62MHz
COMPARATIVE EXAMPLE: FACE (FIG.22)	± 155MHz

[0051] TABLE 1 shows that the distribution is suppressed in Examples 1 to 3 as compared with Comparative Example.

[0052] FIG. 24 shows an assembly of the antenna device according to the first example described above.

[0053] FIG. 24 shows a circuit board **97** viewed from the bottom face on which the antenna device **1** is mounted so that the lower face of the antenna device contacts the upper face of the substrate.

[0054] The ground electrode shown in FIG. 22 is connected to the helical conductor layer via the connection conductor layer on the lower face of the substrate in this type of the antenna device **1**. A hole **97a** piercing from the upper face to the lower face is provided on the circuit board **97** by chipping a part of the circuit board. The contact point between the connection conductor layer and the helical conductor layer on the lower face of the substrate of the antenna device **1** is just located on the hole **97a** to avoid the connection part from contacting to the circuit board **97**.

[0055] FIG. 25 shows another assembly of the antenna device according to the second example described above.

[0056] FIG. 25 also shows a circuit board **97** viewed from the bottom face on which the antenna device **1** of the type shown in FIG. 22 is mounted so that the lower face of the antenna device contact the upper face of the substrate as in FIG. 22.

[0057] Although no chipped portion is provided on the circuit board **97**, the contact portion between the connection conductor and the helical conductor of the antenna device **1** is made to protrude from the circuit board **97**.

[0058] Dispersion of the resonance frequencies can be suppressed by mounting the antenna device so that a part of the circuit board is chipped or the contact portion is allowed to protrude from the circuit board, even when the contact portion is formed on the lower face of the antenna device. TABLE 2 shows the results of measurement of the dispersion of resonance frequencies of the assembly of the antenna device in the examples shown in FIGS. 24 and 25.

TABLE 2 DISPERSION OF RESONANCE FREQUENCY FROM CENTRAL FREQUENCY 2.45 GHz

MOUNTING METHOD	3σ VALUE OF DISPERSION
CHIPPING OF SUBSTRATE UNDER CONTACT POINT (FIG. 24)	± 72MHz
PROTRUSION OF ANTENNA (FIG. 25)	± 68MHz

[0059] TABLE 2 shows that the dispersions of frequencies in this table are smaller as compared with the dispersion in the lowermost row in TABLE 1.

[0060] The foregoing results indicate that the antenna device and the assembly of the antenna device have sufficient performances as an antenna for the portable communication set.

[0061] It is, however, to be noted that the embodiment shown in Fig. 14 is the one covered by the appended claim.

Claims

1. An antenna device (1) comprising:

5 a substrate (2) comprising at least one of a dielectric material or a magnetic material and having upper (21) and lower faces (22) as well as a pair of side faces (23) on which convex portions (232) and concave portions (231) are alternately formed; and
 a helical conductor layer (3, 4, 5) formed on the upper (21) and lower faces (22) and on the concave portion (231) or convex portion (232) on the pair of the side faces (23) of the substrate (2) so as to spirally surround
 10 the entire substrate (2) ;

characterized by

a power feed electrode (5a) for feeding electricity to the helical conductor layer (3, 4, 5), the power feed electrode (5a) comprising a portion located at one end of plural portions sequentially disposed with a given distance apart on
 15 one side face (23) of the substrate (2), said plural portions constituting the helical conductor layer (3, 4, 5);
 an earth electrode (6a) for grounding the helical conductor layer, the earth electrode (6a) being formed at an adjoining position to the power feed electrode (5a) with a given distance apart to the power feed electrode (5a) on the same side face (23) of the substrate (2) as the side face (23) on which the power feed electrode (5a) is formed; and
 a connection conductor layer (6b) extending from the earth electrode (6a) for connecting the earth electrode (6a)
 20 to the power feed electrode (5a) in collaboration with a part of the helical conductor layer (3, 4, 5) by connecting the connection conductor layer (6b) to the helical conductor layer (3, 4, 5) via the upper face (21) of the substrate (2) .

Patentansprüche

1. Antennenvorrichtung (1) mit:

25 einem Substrat (2), das zumindest entweder ein dielektrisches Material oder ein magnetisches Material aufweist und eine obere (21) und eine untere Fläche (22) sowie ein Paar Seitenfläche (23) umfasst, an denen konvexe Abschnitte (232) und konkave Abschnitte (231) abwechselnd ausgebildet sind, und
 30 eine spiralenförmige Leiterschicht (3, 4, 5), die an der oberen (21) und unteren Fläche (22) und am konkaven Abschnitt (231) oder konvexen Abschnitt (232) am Paar der Seitenflächen (23) des Substrats (2) so ausgebildet ist, dass sie das gesamte Substrat (2) spiralförmig umgibt,

gekennzeichnet durch

eine Energiezuführelektrode (5a) zum Zuführen von Elektrizität zur spiralenförmigen Leiterschicht (3, 4, 5), wobei die Energiezuführelektrode (5a) einen Abschnitt aufweist, der an einem Ende mehrerer Abschnitte gelegen ist, die in einem bestimmten Abstand getrennt an einer Seitenfläche (23) des Substrats (2) nacheinander angeordnet sind, wobei die mehreren Abschnitte die spiralenförmige Leiterschicht (3, 4, 5) bilden,
 40 eine Erdungselektrode (6a) zum Erden der spiralenförmigen Leiterschicht (3, 4, 5), wobei die Erdungselektrode (6a) an einer angrenzenden Position zur Energiezuführelektrode (5a) mit einem bestimmten Abstand getrennt zur Energiezuführelektrode (5a) an der gleichen Seitenfläche (23) des Substrats (2) wie der Seitenfläche (23) ausgebildet ist, an der die Energiezuführelektrode (5a) ausgebildet ist, und
 eine Verbindungsleiterschicht (6b), die sich von der Erdungselektrode (6a) zum Verbinden der Erdungselektrode (6a) mit der Energiezuführelektrode (5a) in Zusammenarbeit mit einem Teil der spiralenförmigen Leiterschicht (3, 4, 5) **durch** Verbinden der Verbindungsleiterschicht (6b) über die obere Fläche (21) des Substrats (2) mit der
 45 spiralenförmigen Leiterschicht (3, 4, 5) erstreckt.

Revendications

1. Dispositif d'antenne (1) comprenant :

55 un substrat (2) qui comprend au moins l'un d'un matériau diélectrique ou d'un matériau magnétique et ayant des faces supérieure (21) et inférieure (22) ainsi qu'une paire de faces latérales (23) sur lesquelles des parties convexes (232) et des parties concaves (231) sont formées en alternance ; et
 une couche hélicoïdale conductrice (3, 4, 5) formée sur les faces supérieure (21) et inférieure (22) et sur la partie concave (231) ou partie convexe (232) sur la paire des faces latérales (23) du substrat (2) afin d'entourer

en spirale la totalité du substrat (2) ;

caractérisé par

5 une électrode d'alimentation en électricité (5a) pour alimenter en électricité la couche conductrice hélicoïdale (3, 4, 5), l'électrode d'alimentation en électricité (5a) comprenant une partie située à une extrémité de plusieurs parties disposées de manière séquentielle à une distance donnée sur une face latérale (23) du substrat (2), lesdites plusieurs parties constituant la couche conductrice hélicoïdale (3, 4, 5);
10 une électrode de terre (6a) pour mettre à la terre la couche conductrice hélicoïdale, l'électrode de terre (6a) étant formée à une position adjacente à l'électrode d'alimentation en électricité (5a) à une distance donnée de l'électrode d'alimentation en électricité (5a) sur la même face latérale (23) du substrat (2) que la face latérale (23) sur laquelle l'électrode d'alimentation en électricité (5a) est formée ; et
15 une couche conductrice de liaison (6b) qui s'étend de l'électrode de terre (6a) pour connecter l'électrode de terre (6a) à l'électrode d'alimentation en électricité (5a) en collaboration avec une partie de la couche conductrice hélicoïdale (3, 4, 5) en connectant la couche conductrice de liaison (6b) à la couche conductrice hélicoïdale (3, 4, 5) par la face supérieure (21) du substrat (2).

20

25

30

35

40

45

50

55

FIG.1

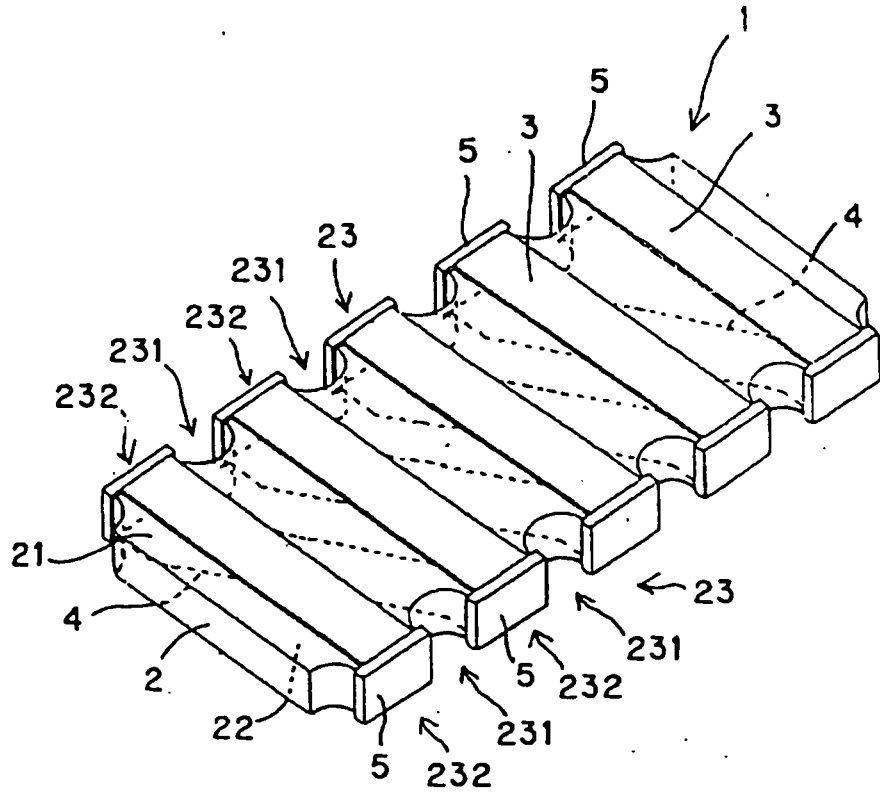

FIG.2

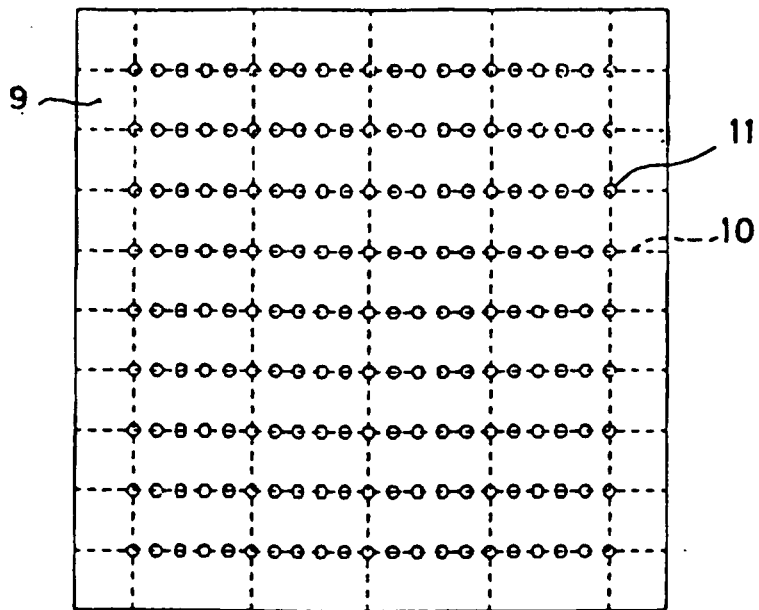

FIG.3

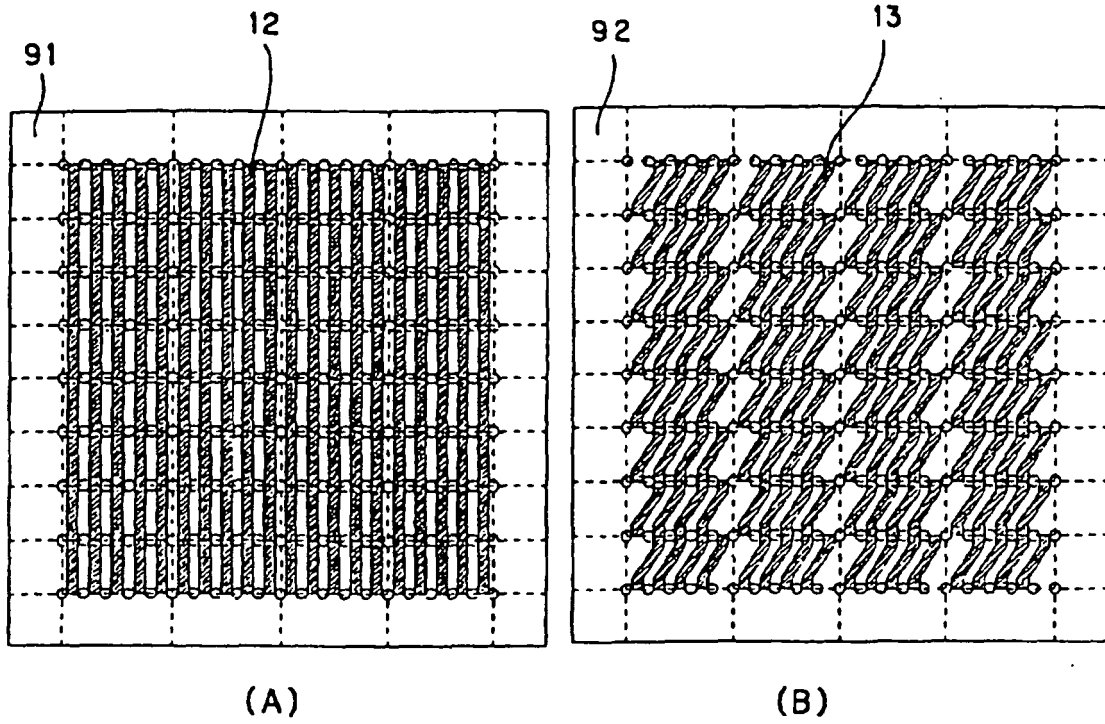

FIG.4

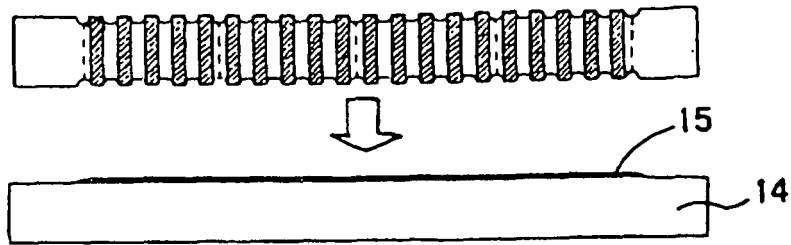

FIG.5

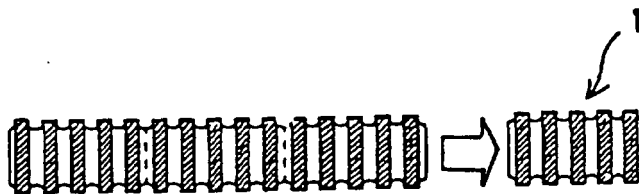

FIG.6

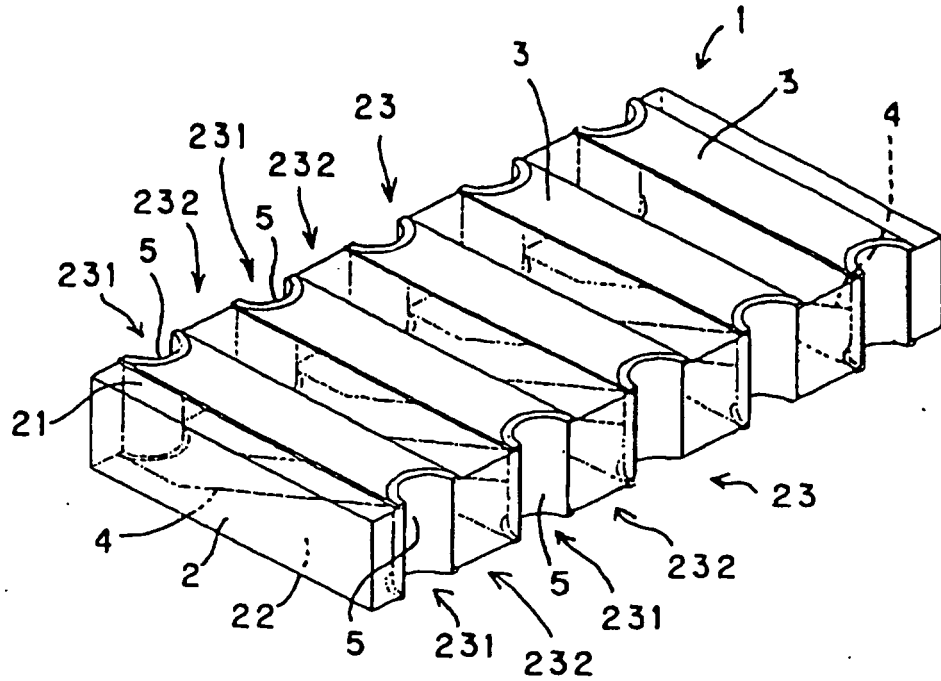

FIG.7

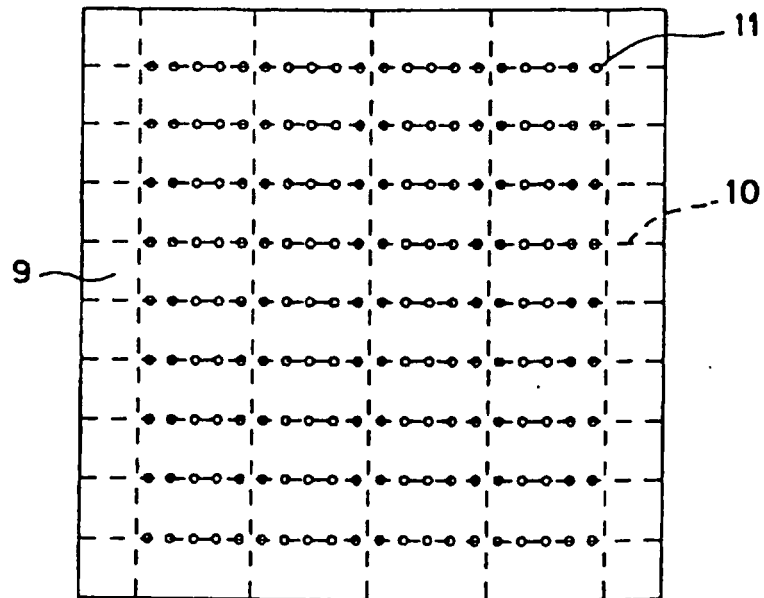

FIG.8

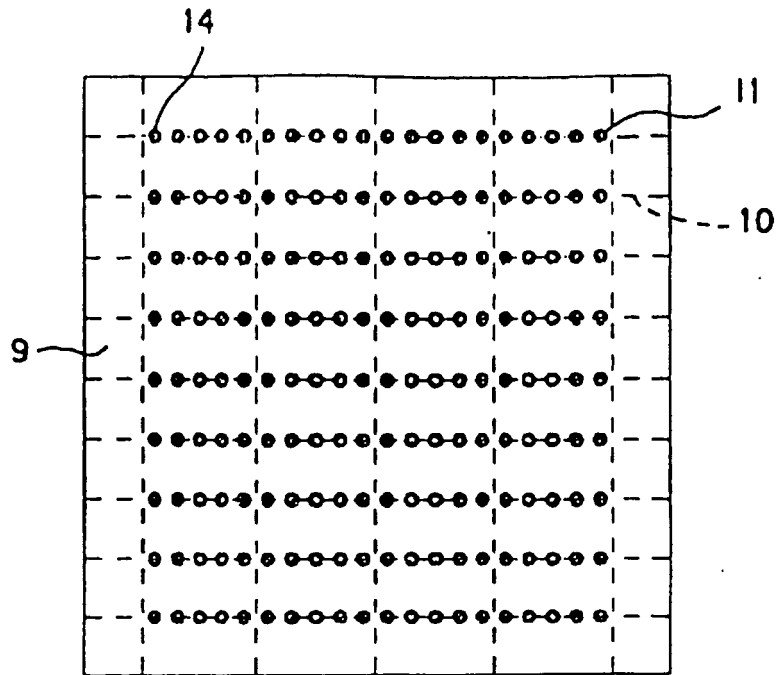

FIG.9

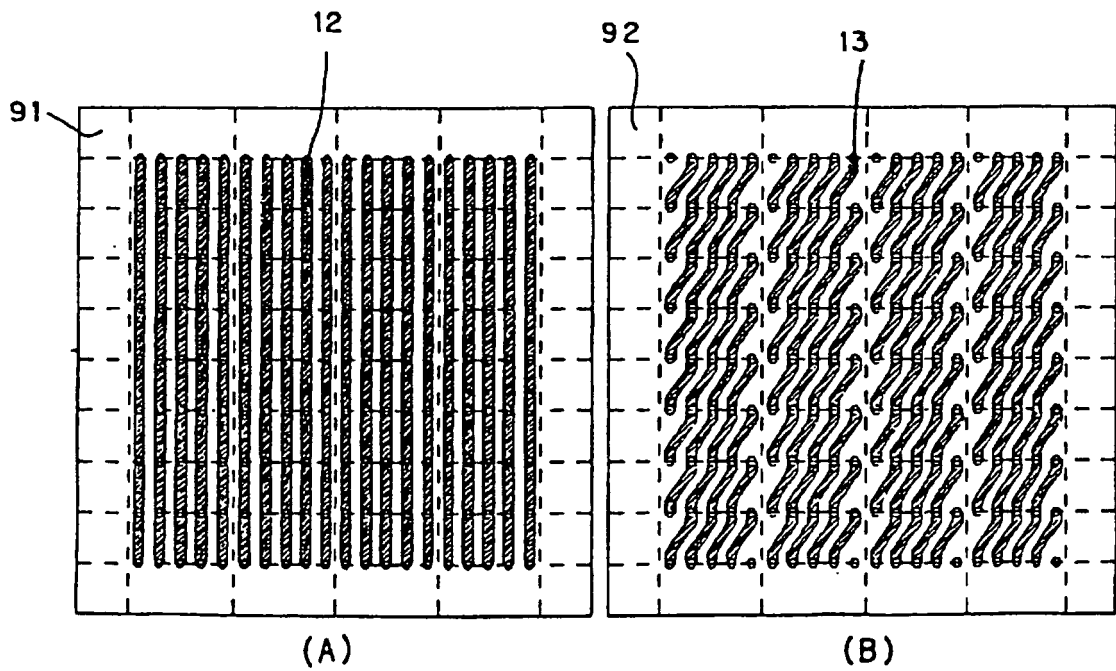

FIG.10

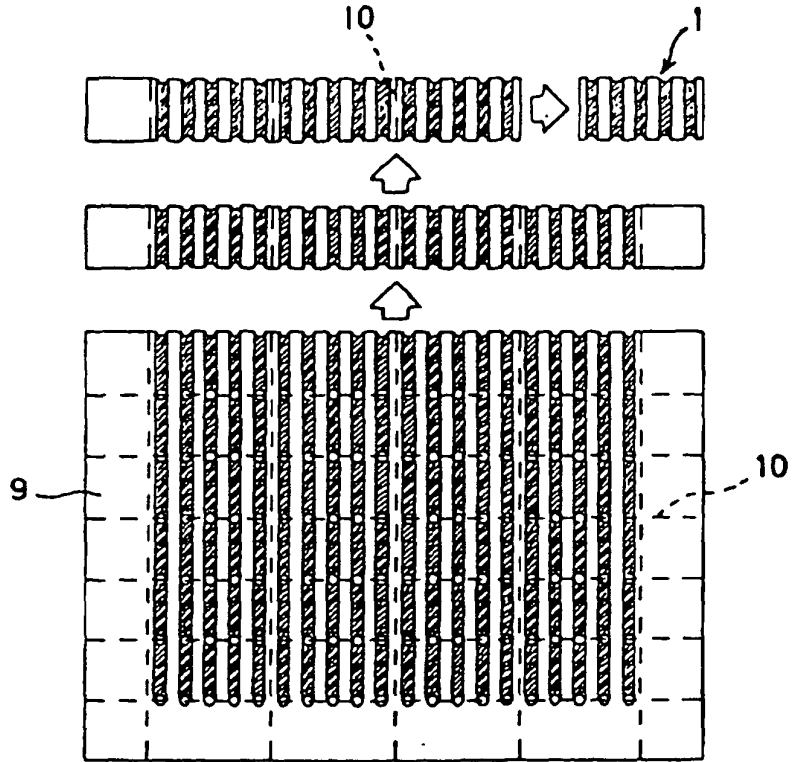

FIG.11

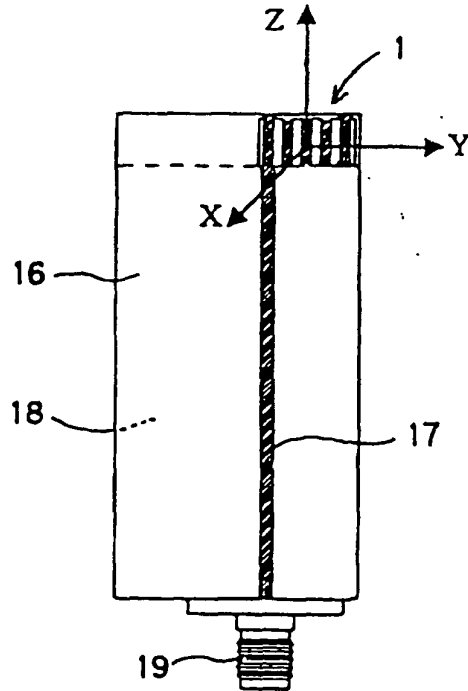

FIG.12

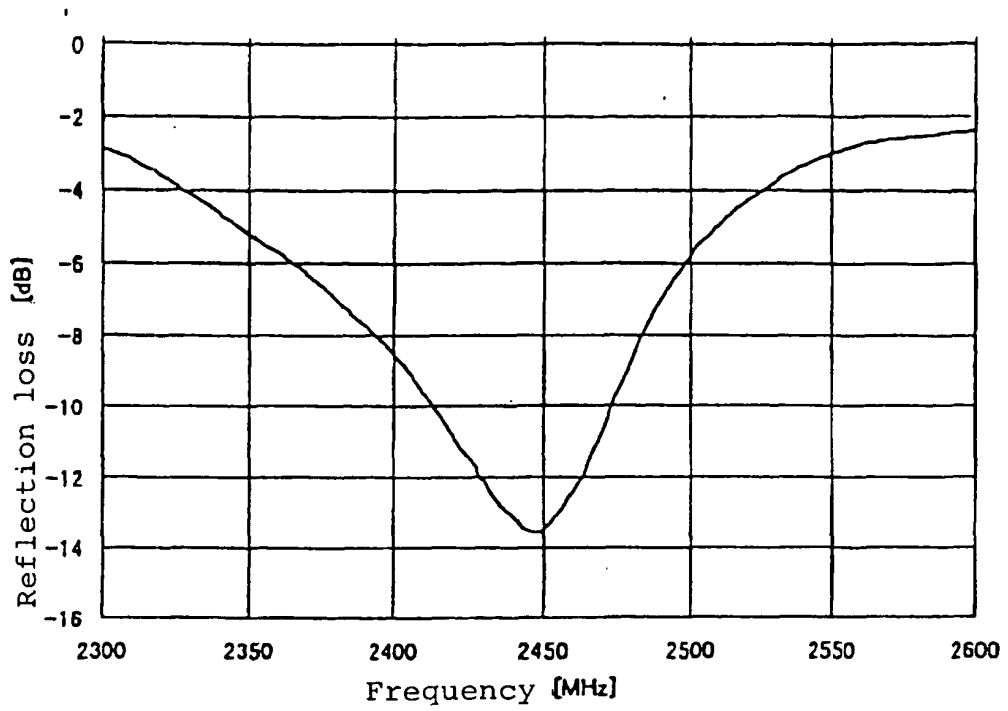

FIG.13

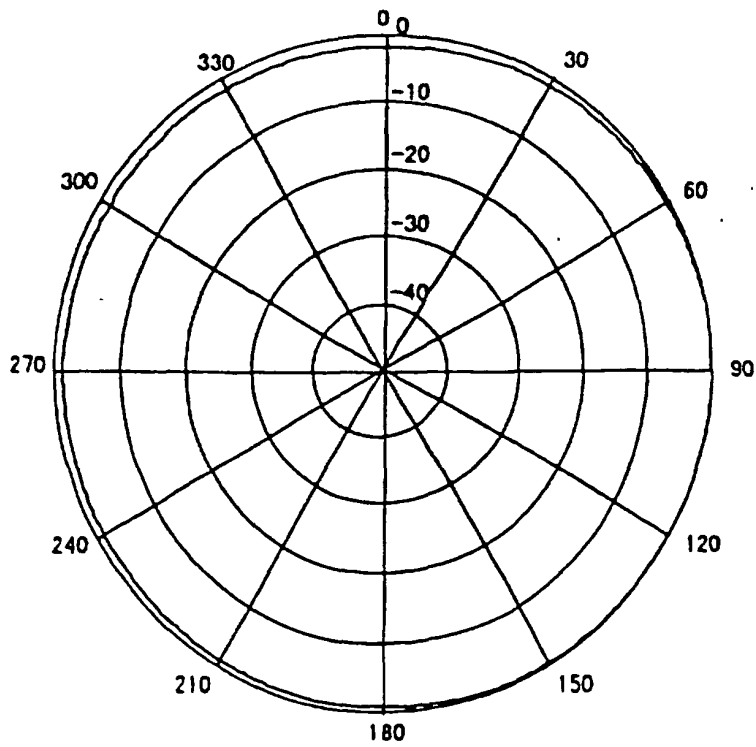

FIG.14

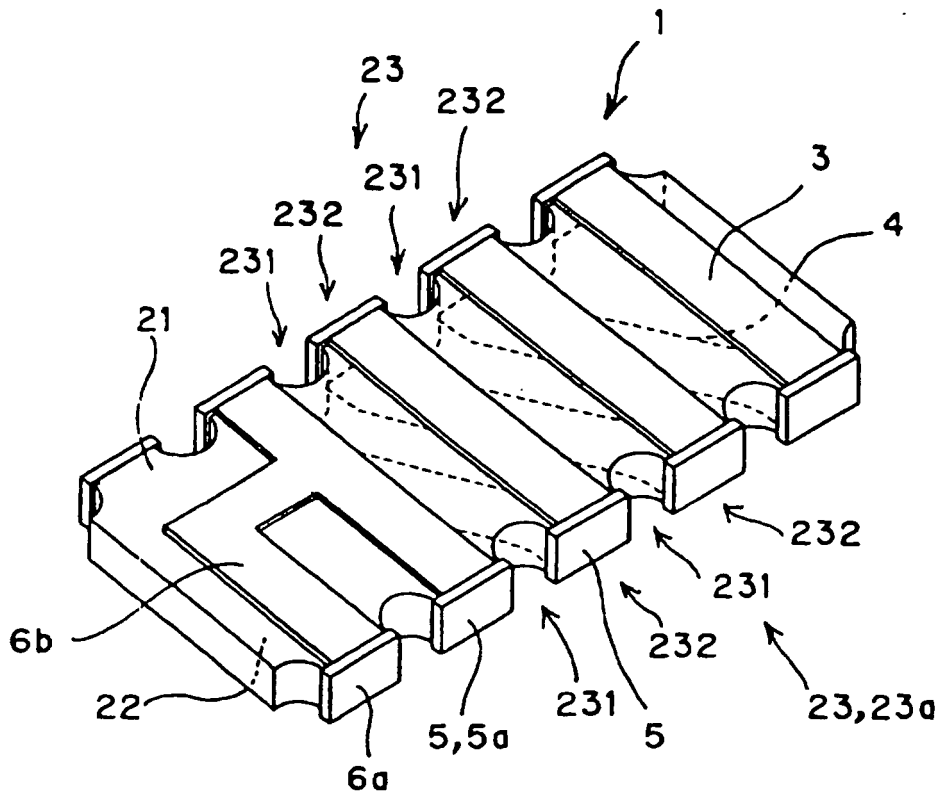

FIG.15

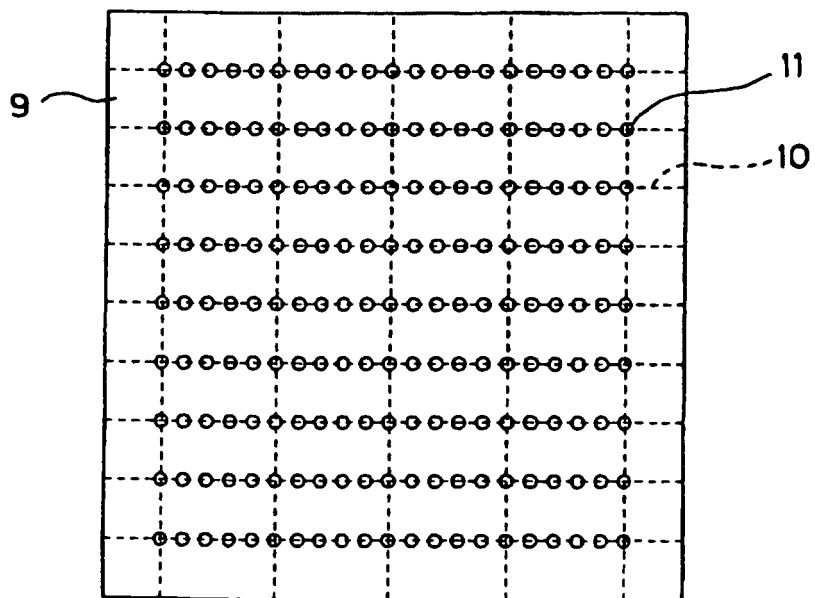

FIG.16

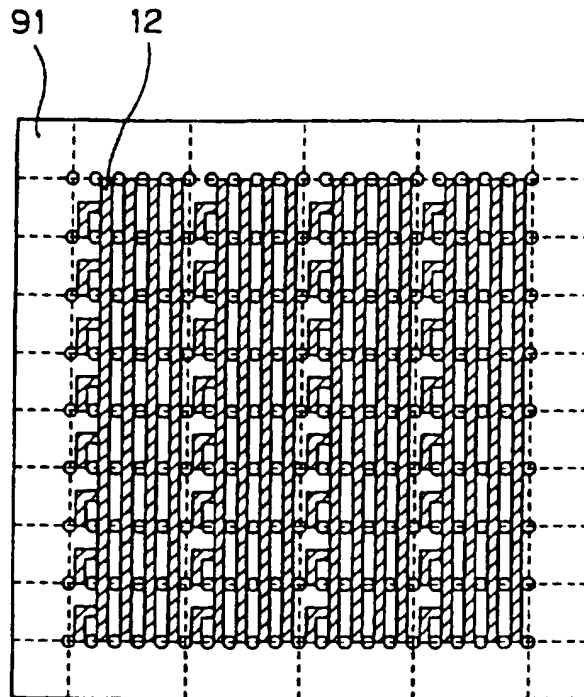

FIG.17

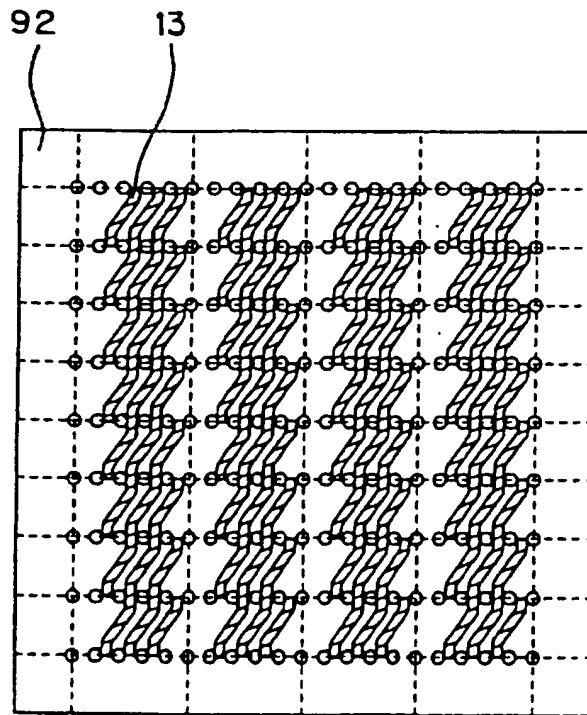

FIG.18

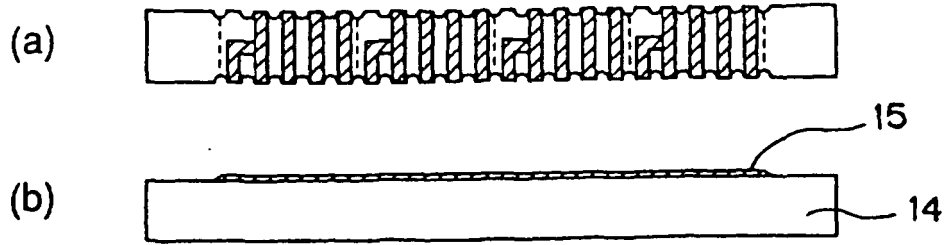

FIG.19



FIG.20

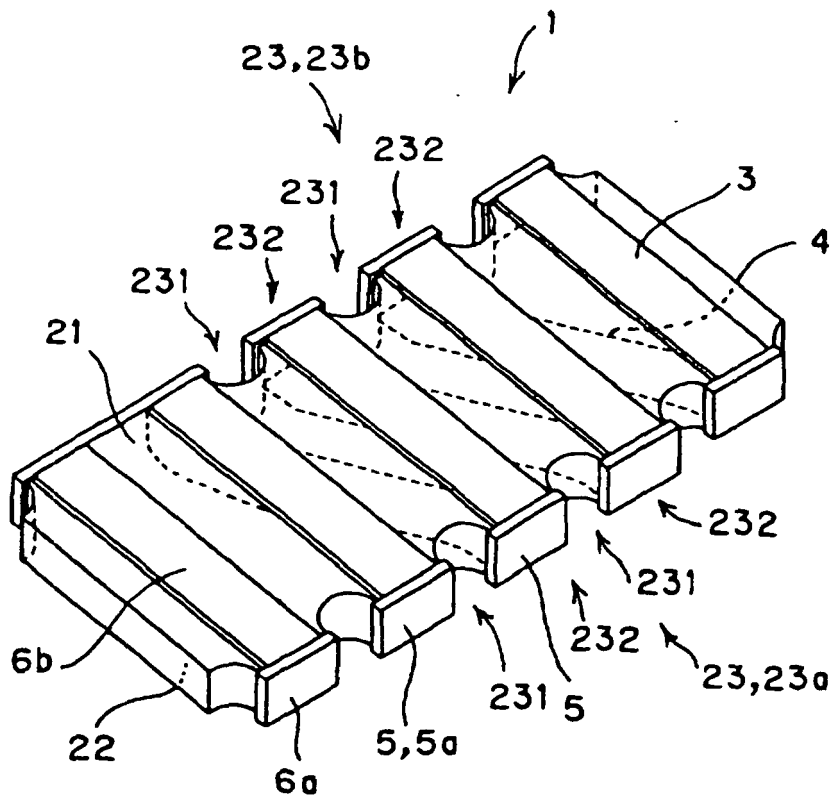

FIG.21

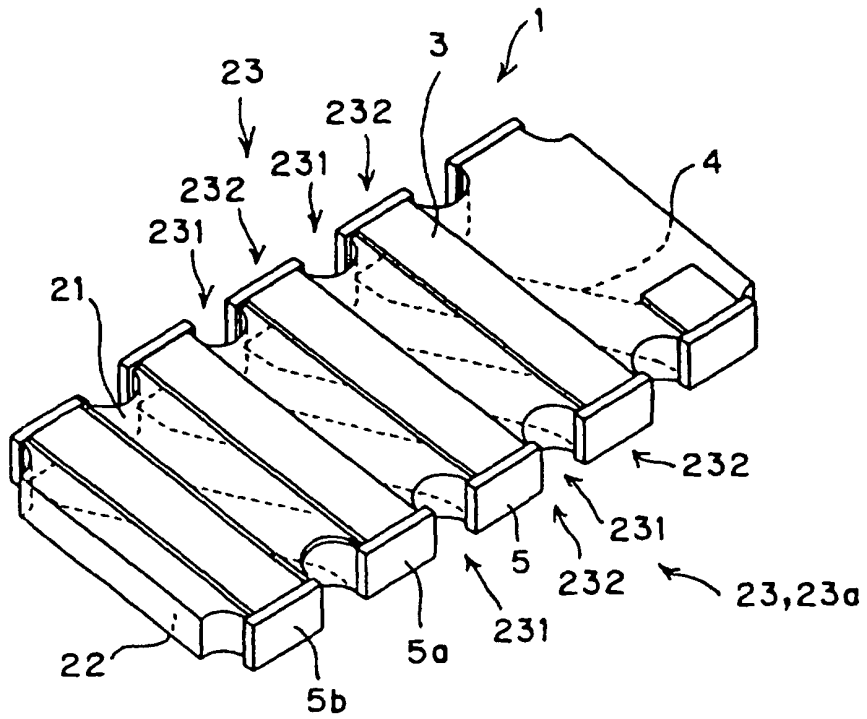

FIG.22

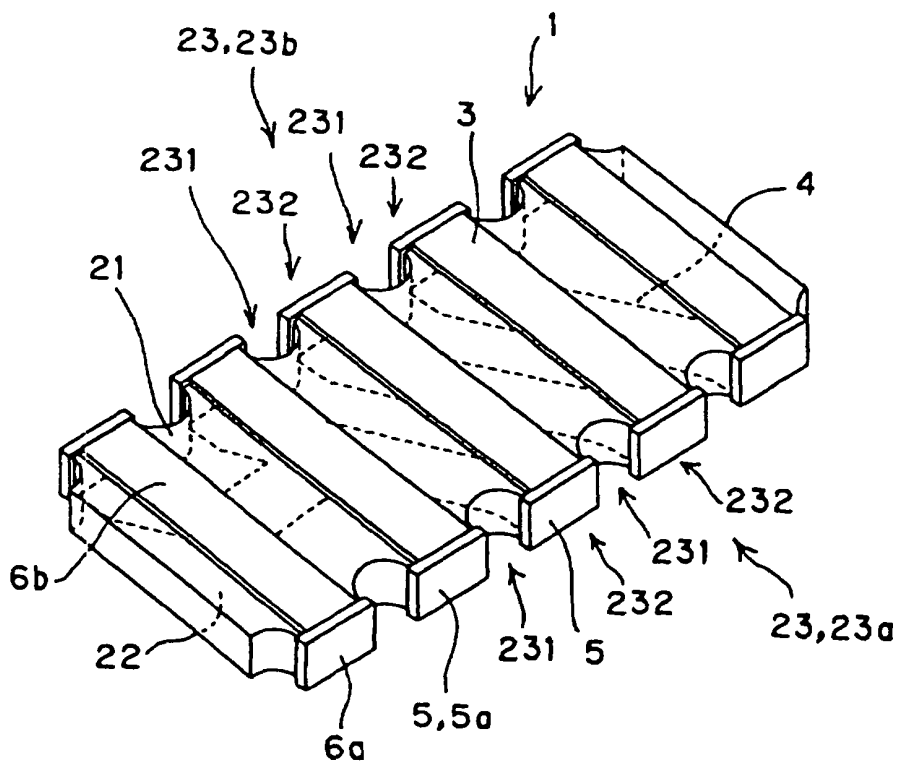

FIG.23

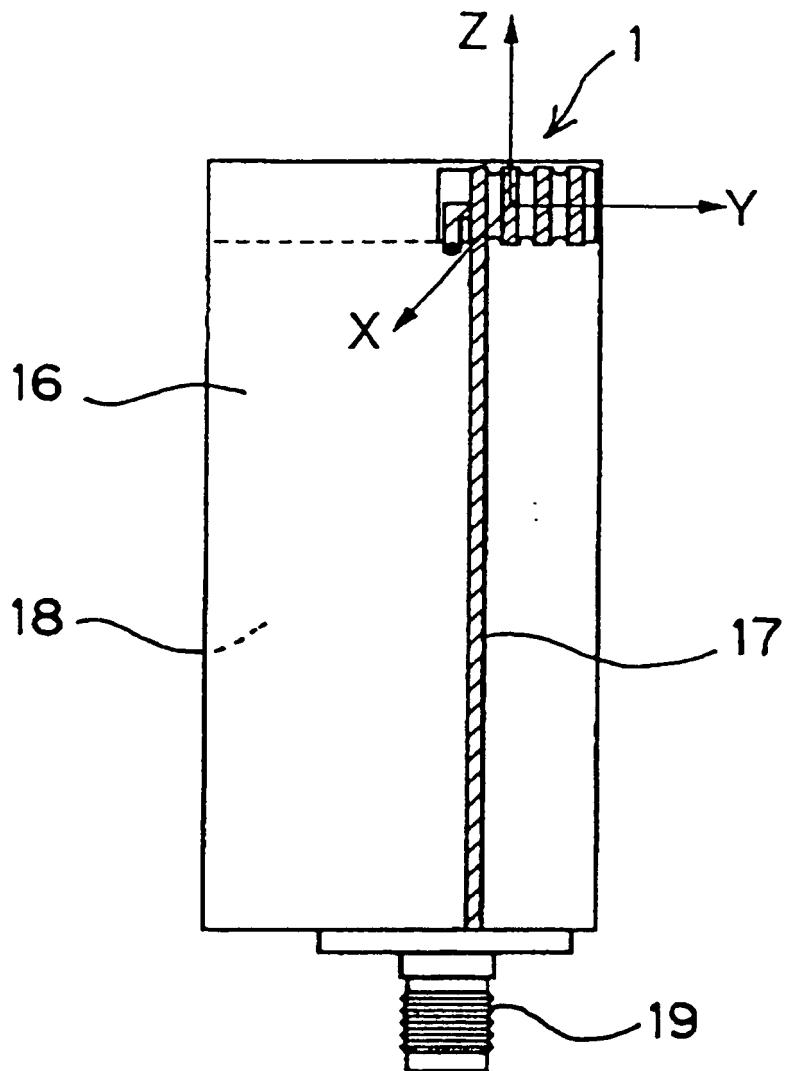

FIG.24

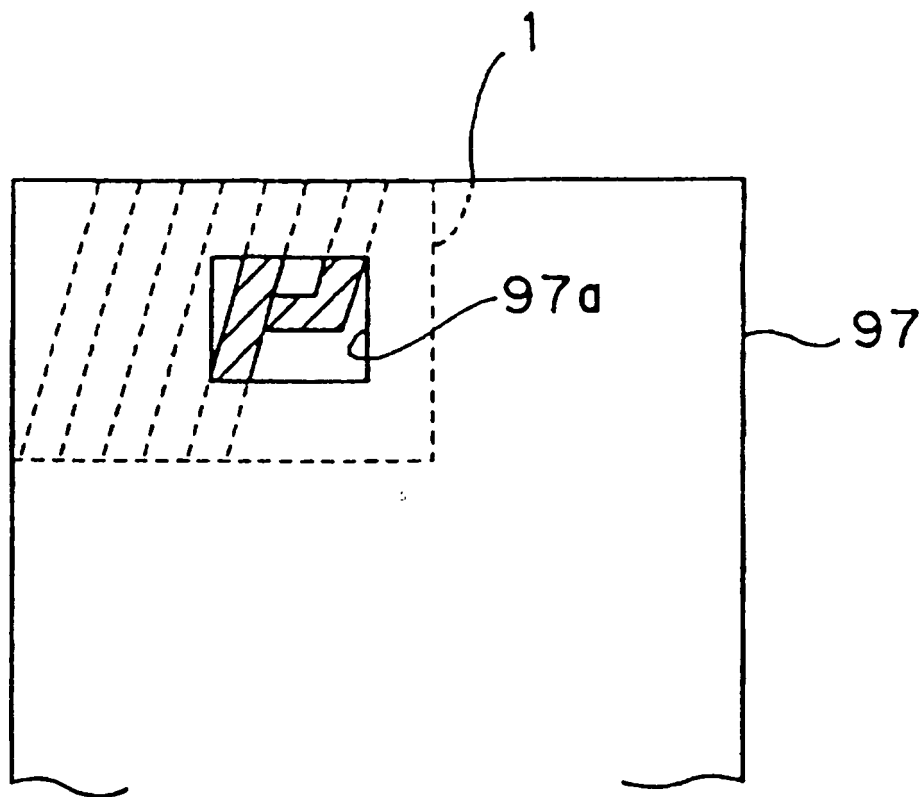

FIG.25

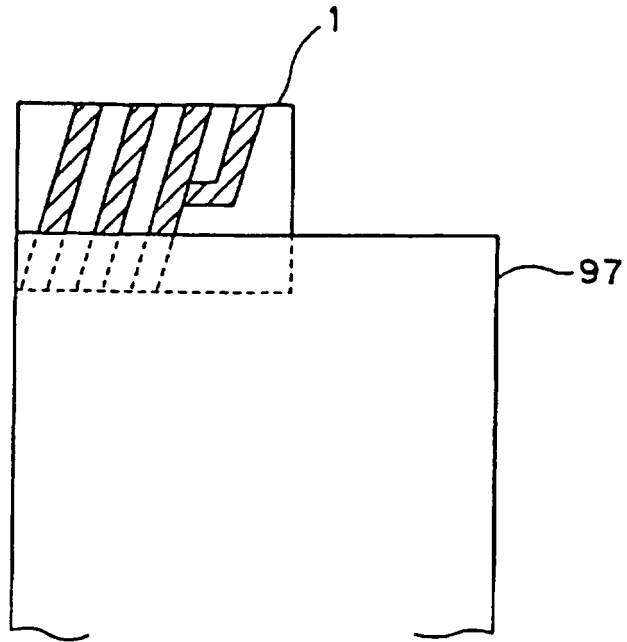
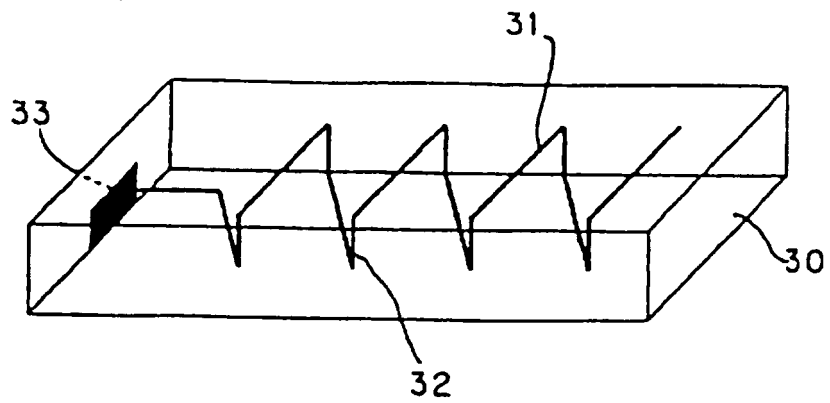

FIG.26



REFERENCES CITED IN THE DESCRIPTION

This list of references cited by the applicant is for the reader's convenience only. It does not form part of the European patent document. Even though great care has been taken in compiling the references, errors or omissions cannot be excluded and the EPO disclaims all liability in this regard.

Patent documents cited in the description

- JP 9064627 A [0003]
- US 5977931 A [0007]