

May 27, 1941.

I. O. SMITH

2,243,262

AUTOMATIC TRAPPED AIR RELEASE

Filed June 15, 1938

2 Sheets-Sheet 1

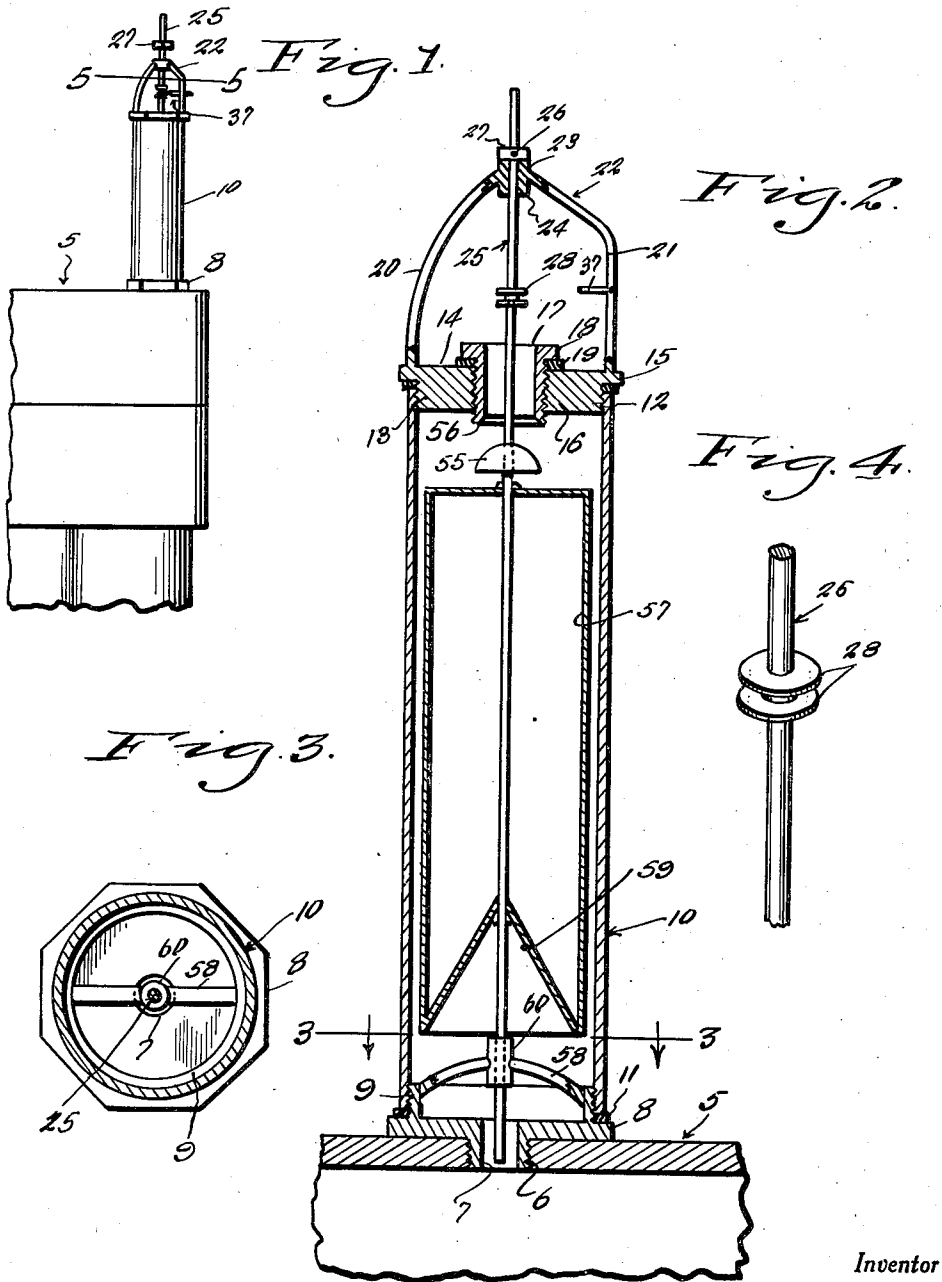

Inventor

Ivan O. Smith

By *Clarence A. O'Brien*
and Hyman Berman
Attorneys

May 27, 1941.

I. O. SMITH

2,243,262

AUTOMATIC TRAPPED AIR RELEASE

Filed June 15, 1938

2 Sheets-Sheet 2

Fig. 5.

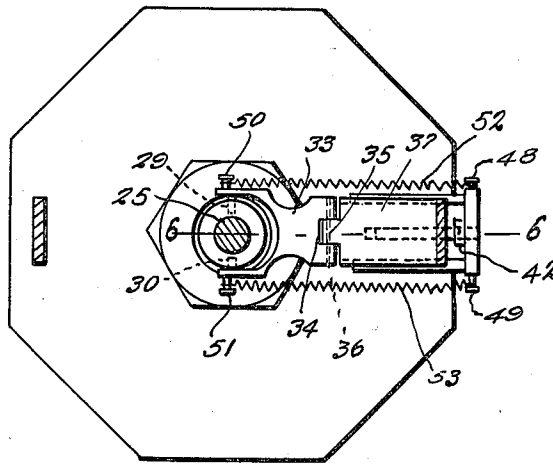

Fig. 7.

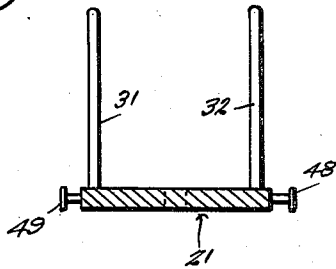

Fig. 6.

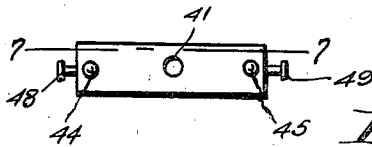
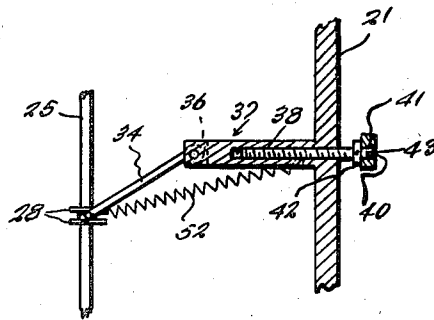
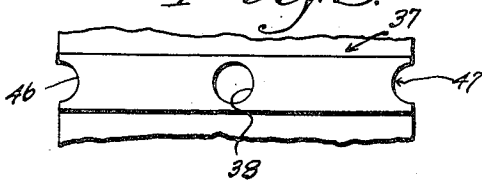

Fig. 8.

Fig. 9.



Inventor

Ivan O. Smith

By *Clarence A. O'Brien*
and Hyman Berman
Attorneys

UNITED STATES PATENT OFFICE

2,243,262

AUTOMATIC TRAPPED AIR RELEASE

Ivan O. Smith, Porthill, Idaho

Application June 15, 1938, Serial No. 213,911

5 Claims. (Cl. 137-69)

My invention relates generally to means for releasing air trapped in fluid containers, and particularly to an arrangement for automatically releasing air trapped in an automobile or stationary internal combustion engine cooling system and the like, and an important object of my invention is to provide a simple and practical arrangement of this character.

Other important objects of my invention will be apparent from a reading of the following description taken in connection with the drawings, wherein for purposes of illustration I have shown a preferred embodiment of my invention.

In the drawings:

Figure 1 is a general elevational view showing the release installed on the cylinder head of an internal combustion engine.

Figure 2 is an enlarged transverse vertical sectional view taken through Figure 1.

Figure 3 is a horizontal sectional view taken through Figure 2 approximately on the line 3-3 and looking downwardly in the direction of the arrows.

Figure 4 is a perspective view of an upper part of the float rod.

Figure 5 is a horizontal sectional view enlarged and taken on the line 5-5 of Figure 1.

Figure 6 is a transverse vertical sectional view taken through Figure 5 approximately on the line 6-6.

Figure 7 is a horizontal sectional view taken through Figure 8 approximately on the line 7-7.

Figure 8 is a top plan view of a portion of the toggle lever.

Figure 9 is an enlarged elevational detail.

Referring in detail to the drawings, the numeral 5 generally designates a cylinder head or other wall of a fluid system from which air is to be automatically vented and in which is provided a threaded opening 6 in which is threaded a nipple 7 on the base 8 which has an exteriorly threaded collar 9 on which collar is threaded the lower end of a cylindrical casing 10 which bears down against a sealing washer 11. The upper end of the cylindrical container 10 is threaded as indicated by the numeral 12 to receive the reduced threaded portion 13 of a nut 14 which has a hexagonal or other suitable shaped flange 15 enabling the use of a wrench in replacing and removing the same. The nut has a threaded central opening 16 in which is threaded a valve seat 17 which has a flange 18 resting on a washer 19 which bears on the top of the nut. Rising from the opposite sides of the top of the nut are the legs 20 and 21 of a wishbone-shaped support

which is generally designated 22 and which has a tubular part 23 at its apex concentrically located over the valve seat and having a bore 24 slidably fitting the upper end of the float rod 25 which has fastened by a set screw 26 above the member 23 the stop 27 for limiting downward movement of the float rod. Intermediate the valve seat and the member 23 is a pair of vertically spaced collars 28 which receives in opposite sides the pins 29 and 30 on the arms 31 and 32 of a yoke 33 which is bifurcated as indicated by the numeral 34 to receive the portion 35, the portion 35 and the arms defined by the bifurcation being traversed by a hinge pin 36 whereby the yoke 33 can hinge upwardly and downwardly relative to the horizontal member 37 of the toggle arm. A longitudinally arranged threaded bore 38 is formed in the horizontal member 37 and in this is threaded an adjusting screw 39 which has a smooth portion 40 turning in a receiving opening 41 in the leg 21 of the wishbone support, with a lock nut 42 adapted to engage the back of the member 21, the outer end of the smooth portion being slotted to receive a screwdriver as indicated by the numeral 43. Extending from opposite sides of the member 21 are smooth horizontal rods 44, 45 which act as slides and are engaged by the semi-circular grooves 46 and 47 in the opposite side edges of the block 37 whereby the block 37 is supported in a horizontal position adjustable toward and away from the member 21 by adjustment of the screw 39. Set screws 48 and 49 in the opposite side edges of the member 21 are arranged to lock the rods 44 and 45 in adjusted extended positions. Between the screws 50, 51 on the opposite legs of the yoke 33 and the set screws 48 and 49 extend contracting springs 52 and 53 which exert only enough tension to hold the arm 34 in a part center position either up or down, so as to positively keep the float and valve from bobbing up and down while air is being vented. When the arm 34 is positioned above center, the springs 52, 53 help to hold the valve 58 tighter up against its seat 56 given the valve 55 by a sufficient rise of the cylindrical float 57. The float is fixed in a suitable manner to the float rod 25 below the valve 55 and above the upwardly bowed cross member 58 which is mounted to the interior of diametrically opposite points of the threaded collar 9 on which the float casing 10 is located. The bottom of the float 57 is conically upset as indicated by the numeral 59 and the cross member 58 has a tubular portion 60 which slidably receives the

lower part of the float rod which depends within the opening in the base 8 as shown in Figure 2.

Supposing that, as takes place in actual practice, the container or tank 5 is drained, for instance to avoid freezing of the liquid therein during the night. As the liquid level subsides in the tank 5 the liquid in the container 10 drains through the opening 7 and into the tank 5, thereby letting the float 57 move down because of the weight of the float and that of the float rod 25, the flanged collar 23, the stop collar 27, and the valve 55. The total weight is sufficient to overcome the tension of the springs 52, 53 and cause the locking arm 34 to swing downwardly past center and arrive at the depressed position thereof illustrated in Figure 6 of the drawings, wherein the valve is open. The springs 52, 53 now hold the arm 34 in the down position past center, and the valve 55 being open the device is ready for refilling of the tank 5.

When the tank 5 has been drained and the valve consequently open, the air has direct unobstructed passage to escape into the surrounding atmosphere. When the empty tank 5 is refilled, the entering liquid displaces the air from the tank 5 and forces it out through the valve and this goes on until the liquid rises in the float chamber 10, still crowding air ahead of it, to a point about three-quarters of the height of the float 57 whereat buoyancy will be imparted to the float with the liquid still rising. The air trapped in the conical float bottom 59 aids the buoyancy of the float, and with continued rise of the liquid in the float chamber the tension of the springs 52, 53 is overcome and the locking arm, accompanied by the valve rod 25 moves upwardly so as to carry the valve 55 into closed position against the valve seat 56, the arm 34 then assuming and retaining the upwardly tilted position with the springs 52, 53 holding it up past the center or horizontal position.

Although I have shown and described herein a preferred embodiment of my invention, it is to be definitely understood that I do not desire to limit the application of the invention thereto, and any change or changes may be made in the materials and in the structure and arrangement of the parts, within the spirit of the invention and the scope of the subjoined claims.

Having described the invention, what is claimed as new is:

1. A venting valve for a liquid container formed with an opening in an upper part thereof, said venting valve comprising a tubular coupling for mounting in said opening, a vertical casing mounted on said coupling and rising thereabove, a top closing the upper end of the casing and having a tubular valve seat therein, a float rod, means on upper and lower parts of the casing for slidably supporting the float rod, a float fixed to said rod below said top, a valve fixed on said float rod between the upper end of the float and said valve seat, said float rod extending through said tubular valve seat and above said top, the said means on the upper part of the casing comprising an arched member on said top, said arched member having a tubular part slidably receiving

the upper part of the float rod, spring operated overcentering means mounted on a side of said arched member and having operative connection with the float rod for seating and unseating said valve on said valve seat.

2. A venting valve for a liquid container formed with an opening in an upper part thereof, said venting valve comprising a tubular coupling for mounting in said opening, a vertical casing mounted on said coupling and rising thereabove, a top closing the upper end of the casing and having a tubular valve seat therein, a float rod, means on upper and lower parts of the casing for slidably supporting the float rod, a float fixed to said rod below said top, a valve fixed on said float rod between the upper end of the float and said valve seat, said float rod extending through said tubular valve seat and above said top, the said means on the upper part of the casing comprising an arched member on said top, said arched member having a tubular part slidably receiving the upper part of the float rod, spring operated overcentering means mounted on a side of said arched member and having operative connection with the float rod for seating and unseating said valve on said valve seat, and means for adjusting the tension of said spring means.

3. A venting valve comprising a float chamber having upper and lower slide brackets, a rod slidably mounted in said slide brackets and having a float attached thereto within said float chamber, a partition across the upper part of the float chamber formed with an opening passing said rod, an annular valve seat mounted on said partition around said opening, a valve fixed on said rod for seating on said valve seat, spring operated overcentering means on one of said slide brackets and having operative connection with said rod for seating and unseating said valve on said valve seat.

4. A venting valve in accordance with claim 3 wherein means is provided for adjusting the tension of said spring operated overcentering means.

5. A venting valve comprising a vertical float chamber closed except for an opening in the bottom and an opening in the top thereof, the bottom opening being arranged for air and fluid connection to the space to be vented and the opening in the top being arranged to vent air from the float chamber, an annular valve seat on said top and in the top, a float rod in said float chamber and extending up through said valve seat and the opening in the top, bracket means slidably supporting and positioning said float rod, a float fixed on the rod within the chamber, a valve on the rod between the float and the said top of the chamber and engageable with said valve seat in an elevated position of the float, spring tensioned toggle lever means supported on said top of the float chamber, and means operatively connecting said toggle lever means to said rod at a point above said top of the float chamber.

IVAN O. SMITH.