



(22) **Date de dépôt/Filing Date:** 2016/08/23

(41) **Mise à la disp. pub./Open to Public Insp.:** 2017/02/25

(45) **Date de délivrance/Issue Date:** 2024/01/09

(30) **Priorité/Priority:** 2015/08/25 (US62/209,715)

(51) **Cl.Int./Int.Cl. H02G 3/08** (2006.01),  
**H01R 13/74** (2006.01)

(72) **Inventeurs/Inventors:**  
DEBARTOLO, JOSEPH V., US;  
MORTUN, SORIN I., US;  
DUMANI, EMIRCAN M., US

(73) **Propriétaire/Owner:**  
HUBBELL INCORPORATED, US

(74) **Agent:** FINLAYSON & SINGLEHURST

(54) **Titre : ASSEMBLAGE DE BOITE DE PLANCHER DOTE D'UN MECANISME DE RETENUE**

(54) **Title: FLOOR BOX ASSEMBLY WITH RETAINER**

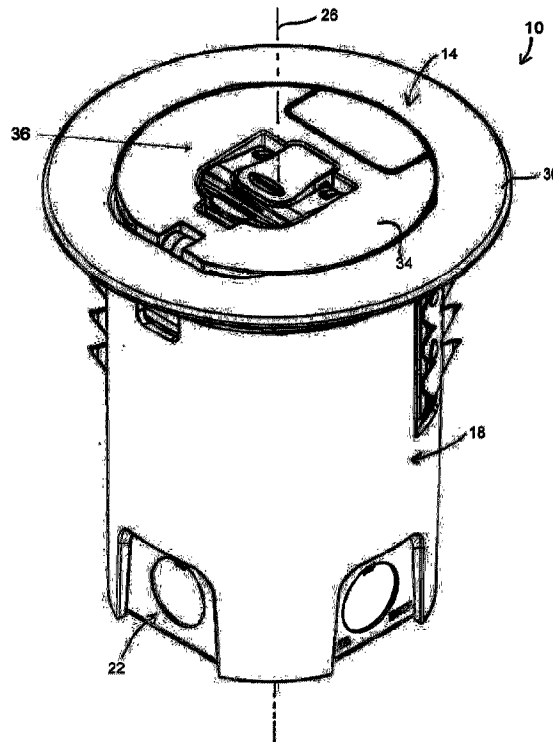

(57) **Abrégé/Abstract:**

A floor box assembly includes a base, a floor box, and at least one retainer coupled to the floor box. The floor box includes an outer wall extending along a longitudinal axis, and the outer wall defines a first end and a second end. The first end is configured to be coupled to an electrical receptacle, and the second end is coupled to the base. The retainer permits the floor box to be inserted into a hole in a first direction along the longitudinal axis and secures the floor box against movement in a second direction opposite the first direction.

Attorney Docket No. 208273-9115-00

## ABSTRACT

A floor box assembly includes a base, a floor box, and at least one retainer coupled to the floor box. The floor box includes an outer wall extending along a longitudinal axis, and the outer wall defines a first end and a second end. The first end is configured to be coupled to an electrical receptacle, and the second end is coupled to the base. The retainer permits the floor box to be inserted into a hole in a first direction along the longitudinal axis and secures the floor box against movement in a second direction opposite the first direction.

Attorney Docket No. 208273-9115-00

## **FLOOR BOX ASSEMBLY WITH RETAINER**

### **BACKGROUND**

**[0001]** This disclosure relates generally to a floor box for housing electrical power and/or low voltage (data, multi-media, A/V & communications) devices. More particularly, the device relates to a floor box for accommodating electrical power and data distribution devices within a floor.

**[0002]** Conventional in-floor boxes for routing electrical power and communication conduit are often used in commercial buildings and the like. In some circumstances, the height of the box is fixed, although the final height of the floor may be different from the height of the box. As a result, the floor box may protrude from the floor or require a means of propping up the floor box. In addition, the floor box may be susceptible to being pulled out of the floor unless the box is secured in place.

### **SUMMARY**

**[0003]** In one aspect, a floor box assembly consistent with one exemplary embodiment includes a base, a floor box, and at least one retainer coupled to the floor box. The floor box includes an outer wall extending along a longitudinal axis, and the outer wall defines a first end and a second end. The first end is configured to be coupled to an electrical receptacle, and the second end is coupled to the base. The retainer permits the floor box to be inserted into a hole in a first direction along the longitudinal axis and secures the floor box against movement in a second direction opposite the first direction.

**[0004]** In another aspect, a floor box assembly includes a base, a floor box, a first retainer, and a second retainer. The floor box includes an outer wall extending along a longitudinal axis. The outer wall defines a first end and a second end; the first end is configured to be coupled to an electrical receptacle, and the second end is coupled to the base. The outer wall includes a first recess and a second recess. The first retainer is positioned within the first recess and includes a first barb extending outwardly from the longitudinal axis. The second retainer is positioned within the second recess and includes a second barb extending outwardly from the longitudinal axis.

**[0005]** In yet another aspect, a method of installing a floor box assembly includes: providing a floor box having an outer wall and a retainer secured to the outer wall, the retainer including a plurality of tapered barbs aligned in a line; and inserting the floor box and retainer into a hole of a surface in a first direction parallel to the line such that the barbs engage a perimeter of the hole to secure the floor box against movement in a second direction opposite the first direction.

**[0005A]** In a broad aspect, the present invention pertains to a floor box assembly comprising a floor box including an outer wall extending along a longitudinal axis, the outer wall including a first end and a second end. The first end is configured to be coupled to an electrical receptacle, and the floor box is configured to receive at least one cable in electrical communication with the receptacle. There is at least one retainer coupled to the floor box, the retainer permitting the floor box to be inserted into an opening in support in a first direction along the longitudinal axis, and securing the floor box against movement in a second direction opposite the first direction. The retainer includes an upper barb and a lower barb spaced vertically from the upper barb along the longitudinal axis.

**[0005B]** In a further aspect, the present invention provides a floor box assembly comprising a floor box including an outer wall extending along a longitudinal axis, the outer wall defining a first end and a second end. The first end is configured to be coupled to an electrical receptacle, the outer wall including a first recess and a second recess, and the floor box configured to receive at least one cable in electrical communication with the receptacle. A first retainer is positioned within the first recess, the first retainer including a first upper barb extending outwardly from the longitudinal axis and a first lower barb extending outwardly from the longitudinal axis and spaced vertically from the first upper barb along the longitudinal axis. A second retainer is positioned within the second recess, the second retainer including a second upper barb extending outwardly from the longitudinal axis and a second lower barb extending outwardly from the longitudinal axis and spaced vertically from the second upper barb along the longitudinal axis.

**[0005C]** In a still further aspect, the present invention provides a floor box assembly comprising a floor box including an outer wall extending along a longitudinal axis, the outer wall including a first end and a second end. The first end is configured to be coupled to an electrical receptacle, the floor box being configured to receive at least one cable in electrical communication with the receptacle. There is at least one retainer coupled to the floor box and including a plurality of barbs. Each of the barbs protrudes

outwardly relative to the outer wall, the retainer permitting the floor box to be inserted into a hole of a surface in a first direction along the longitudinal axis and securing the floor box against movement in a second direction opposite the first direction. The plurality of barbs includes an upper barb and a lower barb spaced vertically from the upper barb along the longitudinal axis.

**[0005D]** In a yet further aspect, the present invention presents a floor box assembly comprising a floor box including an outer wall extending along a longitudinal axis. The outer wall defines a first end and a second end, the first end configured to be coupled to an electrical receptacle, and the floor box being configured to receive at least one cable in electrical communication with the receptacle. A first retainer is positioned on the outer wall, the first retainer including a first upper barb extending outwardly relative to the longitudinal axis and a first lower barb extending outwardly from the longitudinal axis and spaced vertically from the first upper barb along the longitudinal axis. A second retainer is spaced apart from the first retainer on the outer wall, the second retainer including a second upper barb extending outwardly relative to the longitudinal axis and a second lower barb extending outwardly from the longitudinal axis and spaced vertically from the second upper barb along the longitudinal axis.

**[0005E]** Yet further, the present invention embodies a method of installing a floor box assembly. The method comprises providing a floor box having an outer wall and a retainer secured to the outer wall. The retainer includes a plurality of tapered barbs, at least some of the plurality of barbs being aligned along an axis. The method further provides for inserting the floor box and retainer into a hole of a surface in a first direction parallel to the axis such that the barbs engage a perimeter of the hole to secure the floor box against movement in a second direction opposite the first direction.

**[0006]** Other aspects will become apparent by consideration of the detailed description and accompanying drawings.

## **BRIEF DESCRIPTION OF THE DRAWINGS**

- [0007]** FIG. 1 is a perspective view of a floor box assembly.
- [0008]** FIG. 2 is an exploded view of the floor box assembly of FIG. 1.
- [0009]** FIG. 3 is a reverse exploded view of the floor box assembly of FIG. 1.
- [0010]** FIG. 4 is a perspective view of a floor box and retention mechanism.
- [0011]** FIG. 5 is an exploded perspective view of the floor box and retention mechanism of FIG. 4.
- [0012]** FIG. 6 is a perspective view of the retention mechanism of FIG. 4.
- [0013]** FIG. 7 is a front view of the retention mechanism of FIG. 6.
- [0014]** FIG. 8 is a side view of the retention mechanism of FIG. 6.

## **DETAILED DESCRIPTION**

**[0015]** Before any embodiments are explained in detail, it is to be understood that the invention is not limited in its application to the details of construction and the arrangement of components set forth in the following description or illustrated in the following drawings. The invention is capable of other embodiments and of being practiced or of being carried out in various ways.

Attorney Docket No. 208273-9115-00

**[0016]** Also, it is to be understood that the phraseology and terminology used herein is for the purpose of description and should not be regarded as limiting. Use of "including" and "comprising" and variations thereof as used herein is meant to encompass the items listed thereafter and equivalents thereof as well as additional items. Use of "consisting of" and variations thereof as used herein is meant to encompass only the items listed thereafter and equivalents thereof. Unless specified or limited otherwise, the terms "mounted," "connected," "supported," and "coupled" and variations thereof are used broadly and encompass both direct and indirect mountings, connections, supports, and couplings.

**[0017]** As used herein "substantially", "generally", and other words of degree, are used as a relative modifier intended to indicate permissible variation from the characteristic so modified. It is not intended to be limited to the absolute value or characteristic, which it modifies but rather approaching or approximating such a physical or functional characteristic.

**[0018]** FIGS. 1-3 illustrate a floor box assembly 10 consistent with one or more exemplary embodiments. The floor box assembly 10 includes a cover 14, a riser or floor box 18, and a base 22. The cover 14, floor box 18, and base 22 are stacked together along a longitudinal axis 26. In one embodiment, the cover 14 includes an outer portion 30 and a movable door 34. The door 34 may be opened to expose an electrical receptacle (not shown).

**[0019]** As shown in FIG. 4, the floor box 18 has a generally cylindrical outer wall 38 and includes a first or upper end 42 and a second or lower end 46. In the illustrated embodiment, the floor box 18 extends along the longitudinal axis 26. The upper end 42 includes an opening for receiving the cover 14. The lower end 46 includes cutouts 50. Referring to FIGS. 2 and 3, the base 22 is coupled to the lower end 46 (e.g., by fasteners 54). In the illustrated embodiment, the base 22 includes a lower wall 62 and a plurality of upstanding walls or tabs 66 extending upwardly from the lower wall 62. Each tab 66 extends into the cutouts 50 in the outer wall 38 of the floor box 18. The edge of each tab 66 may be received in a groove 70 (FIG. 3) extending around each cutout 50. Each tab 66 includes an opening 74 for receiving a conduit, which may include power and/or data cable(s).

**[0020]** Referring to FIG. 5, the floor box 18 further includes longitudinal recesses 78 formed in the outer wall 38. In the illustrated embodiment, the outer wall 38 includes two recesses 78

Attorney Docket No. 208273-9115-00

positioned 180 degrees apart from one another on the outer surface of the outer wall 38. In other embodiments, the side wall may include fewer or more recesses 78, and the recesses 78 may be spaced apart from one another at an angle less than 180 degrees.

**[0021]** As shown in FIGS. 4 and 5, the floor box assembly 10 further includes a locking mechanism or retainer 90 positioned within each recess 78. As discussed above, although two retainers 90 are illustrated in FIGS. 1 through 5, fewer or more retainers 90 may be secured to the outer wall 38. In one embodiment, a single retainer may be wrapped around a perimeter of the outer wall 38. As shown in FIG. 5, each retainer 90 may be secured within the recess 78 by a fastener(s) 94. The retainer 90 may also be captured or secured to the floor box 18 in a different manner.

**[0022]** Referring to FIGS. 6-8, in the illustrated embodiment the retainer 90 is formed as a bracket including a first or upper end 102, a second or lower end 106, and a pair of side edges 110 extending between the upper end 102 and the lower end 106. The retainer 90 defines a generally planar shape but includes a step 114 (FIG. 8). Each retainer 90 includes a projection 122 positioned at the upper end 102 and a plurality of barbs 126 positioned along the side edges 110 of the retainer 90. Each barb 126 is tapered such that a portion of the barb 126 proximate the lower end 106 of the retainer 90 protrudes less than a portion of the barb 126 positioned proximate the upper end 102. In one embodiment, each barb 126 may incorporate a linear taper; in other embodiments, one or more barbs 126 may incorporate a taper having a different shape.

**[0023]** In the illustrated embodiment, the projection 122 extends perpendicular to the plane of the retainer 90, outwardly away from the axis 26. In addition, the retainer 90 of the illustrated embodiment includes a pair of parallel side edges 110, and four barbs 126 protrude outwardly from the plane of the retainer 90 and are arranged linearly and vertically along each side edge 110. The barbs 126 extend outwardly from the retainer 90 along a profile that is partially arcuate. In other embodiments, the retainer 90 may include fewer or more barbs 126, and the barbs 126 may extend outwardly from the retainer 90 in another direction. In addition, the retainer 90 may include fewer or more rows of barbs 126 compared to the two rows in the illustrated embodiment.

Attorney Docket No. 208273-9115-00

**[0024]** As shown in FIGS. 6-8, the retainer 90 further includes a tab 142 positioned adjacent the lower end 106. The tab 142 is configured to be inserted into a slot 146 (FIG. 5) adjacent the recess 78 to align the retainer 90 with the recess 78.

**[0025]** The floor box assembly 10 may be inserted into a hole in a floor (not shown) or other support surface. The tapered shape of each barb 126 allows the floor box assembly 10 to be inserted, but actively engages the surrounding surface to prevent the floor box 18 or the rest of the assembly 10 from being removed. Because the retainers 90 include barbs 126 at multiple positions along the height of each bracket, the barbs 126 are capable of engaging floors or support surfaces in a range of thicknesses. The retainer 90 may be used with a variety of materials, such as wood, tile, or concrete. In addition, the projections 122 provide a stop surface to engage the edge of the hole and prevent the floor box assembly 10 from being inserted too far into the hole. Each retainer 90 is formed from sheet metal to provide flexibility and durability to the structure of the retainer 90.

**[0026]** It would be understood that a device or method incorporating any of the additional or alternative details mentioned above would fall within the scope of the disclosure as determined based upon the claims below and any equivalents thereof.

**[0027]** Other aspects, objects and advantages of the disclosure can be obtained from a study of the drawings, the disclosure and the appended claims. Although certain embodiments have been described in detail, variations and modifications exist within the scope and spirit of one or more independent aspects as described.

## **WHAT IS CLAIMED IS:**

1. A floor box assembly comprising:

a floor box including an outer wall extending along a longitudinal axis, the outer wall including a first end and a second end, the first end configured to be coupled to an electrical receptacle, the floor box configured to receive at least one cable in electrical communication with the receptacle; and

at least one retainer coupled to the floor box, the retainer permitting the floor box to be inserted into an opening in a support in a first direction along the longitudinal axis and securing the floor box against movement in a second direction opposite the first direction,

the retainer including an upper barb and a lower barb spaced vertically from the upper barb along the longitudinal axis.

2. The floor box assembly of claim 1, further comprising a cover coupled to the first end of the floor box.

3. The floor box assembly of claim 1, wherein the outer wall includes a cylindrical portion extending at least partially between the first end and the second end.

4. The floor box assembly of claim 1, wherein the outer wall includes at least one recess extending parallel to the longitudinal axis, the retainer secured to the outer wall and positioned within the recess.

5. The floor box assembly of claim 1, wherein the retainer includes a first retainer end and a second retainer end, wherein the first retainer end includes a projection extending at an angle away from the longitudinal axis.

6. The floor box assembly of claim 1, wherein the retainer includes a first retainer end, a second retainer end, and wherein the upper and lower barbs are positioned between the first retainer end and the second retainer end, wherein each barb is shaped such that a portion of the barb proximate the first end of the outer wall is larger than a portion of the barb proximate the second end of the outer wall.

7. The floor box assembly of claim 6, wherein each barb is tapered from the first end toward the second end.

8. The floor box assembly of claim 6, wherein the barbs are aligned along a line parallel to the longitudinal axis.

9. The floor box assembly of claim 6, wherein the barbs include a first upper barb, a first lower barb, a second upper barb, and a second lower barb, and wherein the first upper barb and the first lower barb are laterally spaced apart from the second upper barb and the second lower barb.

10. The floor box assembly of claim 1, wherein the outer wall of the floor box includes a slot, wherein the retainer includes a tab positioned adjacent the second end, the tab received within the slot of the outer wall.

11. The floor box assembly of claim 1, wherein the retainer includes a pair of retainers, the retainers coupled to the outer wall and spaced apart from one another by 180 degrees.

12. A floor box assembly comprising:

a floor box including an outer wall extending along a longitudinal axis, the outer wall defining a first end and a second end, the first end configured to be coupled to an electrical receptacle, the outer wall including a first recess and a second recess, the floor box configured to receive at least one cable in electrical communication with the receptacle;

a first retainer positioned within the first recess, the first retainer including a first upper barb extending outwardly from the longitudinal axis and a first lower barb extending outwardly from the longitudinal axis and spaced vertically from the first upper barb along the longitudinal axis; and

a second retainer positioned within the second recess, the second retainer including a second upper barb extending outwardly from the longitudinal axis and a second lower barb extending outwardly from the longitudinal axis and spaced vertically from the second upper barb along the longitudinal axis.

13. The floor box assembly of claim 12, wherein each retainer includes a first retainer end positioned proximate the first end of the floor box and a second retainer end positioned proximate the second end of the floor box, wherein the first retainer end includes a projection extending at an angle away from the longitudinal axis.

14. The floor box assembly of claim 12, wherein each barb is formed such that a portion of the barb proximate the first end of the floor box is larger than a portion of the barb proximate the second end of the floor box.

15. The floor box assembly of claim 12, wherein the first upper barb and the first lower barb are aligned along a line parallel to the longitudinal axis, wherein the second upper barb and the second lower barb are aligned along a line parallel to the longitudinal axis.

16. The floor box assembly of claim 12, wherein the first retainer includes a pair of first upper barbs laterally offset from one another, wherein the second retainer includes a pair of second upper barbs laterally offset from one another.

17. The floor box assembly of claim 12, wherein the outer wall of the floor box includes a first slot positioned adjacent the first recess, wherein first retainer includes a tab received within the slot of the outer wall.

18. The floor box assembly of claim 12, wherein the first recess and the second recess are spaced apart by 180 degrees about the longitudinal axis.

19. The floor box assembly of claim 12, wherein each retainer includes a projection positioned proximate the first end of the floor box, the projection extending perpendicularly relative to the longitudinal axis.

20. A floor box assembly comprising:

a floor box including an outer wall extending along a longitudinal axis, the outer wall including a first end and a second end, the first end configured to be coupled to an electrical receptacle, the floor box configured to receive at least one cable in electrical communication with the receptacle; and

at least one retainer coupled to the floor box and including a plurality of barbs, each of the barbs protruding outwardly relative to the outer wall, the retainer permitting the floor box to be inserted into a hole of a surface in a first direction along the longitudinal axis and securing the floor box against movement in a second direction opposite the first direction, wherein the plurality of barbs includes an upper barb and a lower barb spaced vertically from the upper barb along the longitudinal axis.

21. The floor box assembly of claim 20, further comprising a cover coupled to the first end of the floor box.

22. The floor box assembly of claim 20, wherein the outer wall includes a cylindrical portion extending at least partially between the first end and the second end, wherein each retainer is secured to an outer surface of the outer wall.

23. The floor box assembly of claim 20, wherein the outer wall includes at least one recess extending parallel to the longitudinal axis, the retainer secured to the outer wall and positioned within the recess.

24. The floor box assembly of claim 20, wherein the retainer includes a first end and a second end, wherein the first end includes a projection extending at an angle away from the longitudinal axis.

25. The floor box assembly of claim 20, wherein the retainer includes a body, wherein each barb includes a portion extending outwardly relative to the outer wall at a first retainer end, and a second retainer end proximate the body, and wherein each barb tapers from the portion toward the second retainer end.

26. The floor box assembly of claim 20, wherein the barbs are aligned along a line parallel to the longitudinal axis.

27. The floor box assembly of claim 20, wherein the barbs include a first set of upper and lower barbs and a second set of upper and lower barbs laterally spaced apart from the first set of barbs.

28. The floor box assembly of claim 20, wherein the outer wall of the floor box includes a slot, wherein each retainer includes a tab positioned adjacent an end of the retainer, the tab received within the slot.

29. The floor box assembly of claim 20, wherein the retainer includes a pair of retainers, the retainers coupled to the outer wall and spaced apart from one another by 180 degrees.

30. A floor box assembly comprising:

a floor box including an outer wall extending along a longitudinal axis, the outer wall defining a first end and a second end, the first end configured to be coupled to an electrical receptacle, the floor box configured to receive at least one cable in electrical communication with the receptacle;

a first retainer positioned on the outer wall, the first retainer including a first upper barb extending outwardly relative to the longitudinal axis and a first lower barb extending outwardly from the longitudinal axis and spaced vertically from the first upper barb along the longitudinal axis; and

a second retainer spaced apart from the first retainer on the outer wall, the second retainer including a second upper barb extending outwardly relative to the longitudinal axis and a second lower barb extending outwardly from the longitudinal axis and spaced vertically from the second upper barb along the longitudinal axis.

31. The floor box assembly of claim 30, wherein the outer wall includes a first recess and a second recess, the first retainer positioned within the first recess and the second retainer positioned within the second recess.
32. The floor box assembly of claim 30, wherein each retainer includes a first retainer end positioned proximate the first end of the floor box and a second retainer end positioned proximate the second end of the floor box, wherein the first retainer end includes a projection extending at an angle away from the longitudinal axis.
33. The floor box assembly of claim 30, wherein each retainer includes a body, and wherein each barb tapers from a portion extending outwardly relative to the longitudinal axis to the body.
34. The floor box assembly of claim 30, wherein the first upper barb and the first lower barb are aligned along a line parallel to the longitudinal axis, wherein the second upper barb and the second lower barb are aligned along a line parallel to the longitudinal axis.
35. The floor box assembly of claim 30, wherein the first retainer includes a pair of first upper barbs laterally offset from one another, wherein the second retainer includes a pair of second upper barbs laterally offset from one another.
36. The floor box assembly of claim 30, wherein the outer wall includes a first recess and a second recess, and wherein the first recess and the second recess are spaced apart by 180 degrees about the longitudinal axis.
37. The floor box assembly of claim 30, wherein each retainer includes a projection positioned proximate the first end of the floor box, the projection extending perpendicularly relative to the longitudinal axis.
38. The floor box assembly of claim 30, wherein each retainer includes a body having a first retainer end and a second retainer end, and wherein each barb is coupled to the body between the first retainer end and the second retainer end along a line parallel to the longitudinal axis.

39. A method of installing a floor box assembly, the method comprising:  
providing a floor box having an outer wall and a retainer secured to the outer wall, the retainer including a plurality of tapered barbs, at least some of the plurality of barbs aligned along an axis; and  
inserting the floor box and retainer into a hole of a surface in a first direction parallel to the axis such that the barbs engage a perimeter of the hole to secure the floor box against movement in a second direction opposite the first direction.

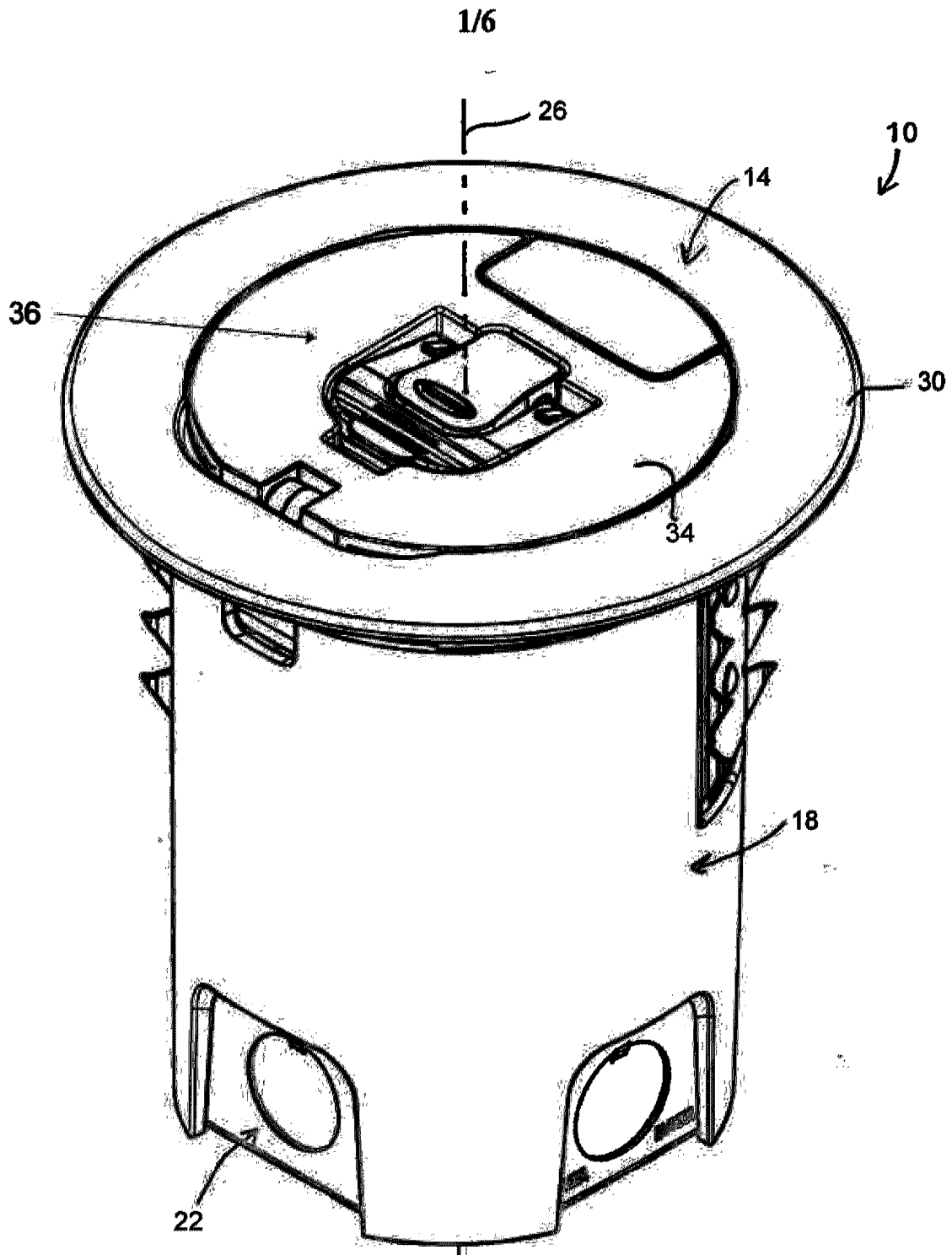

**FIG. 1**

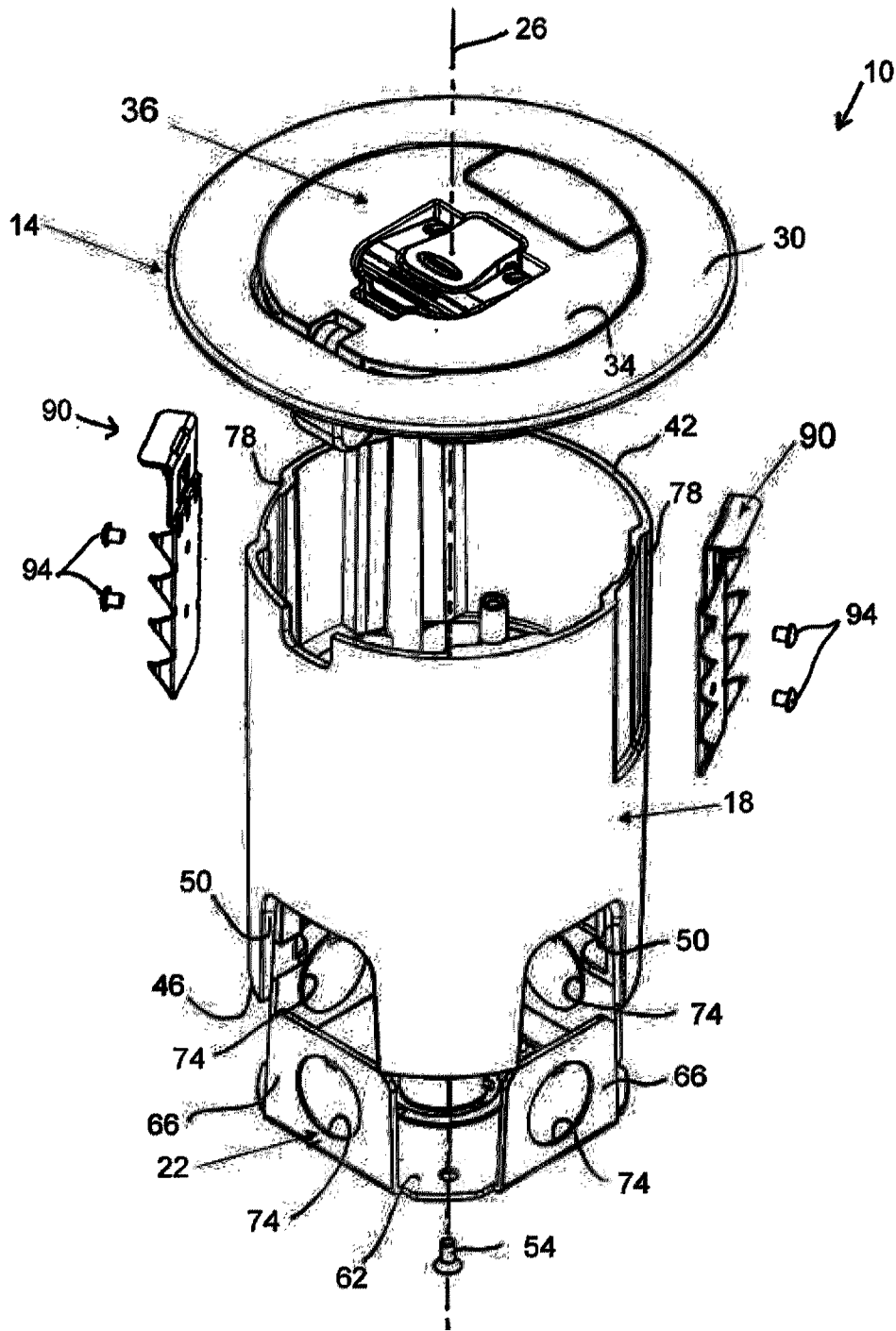

**FIG. 2**

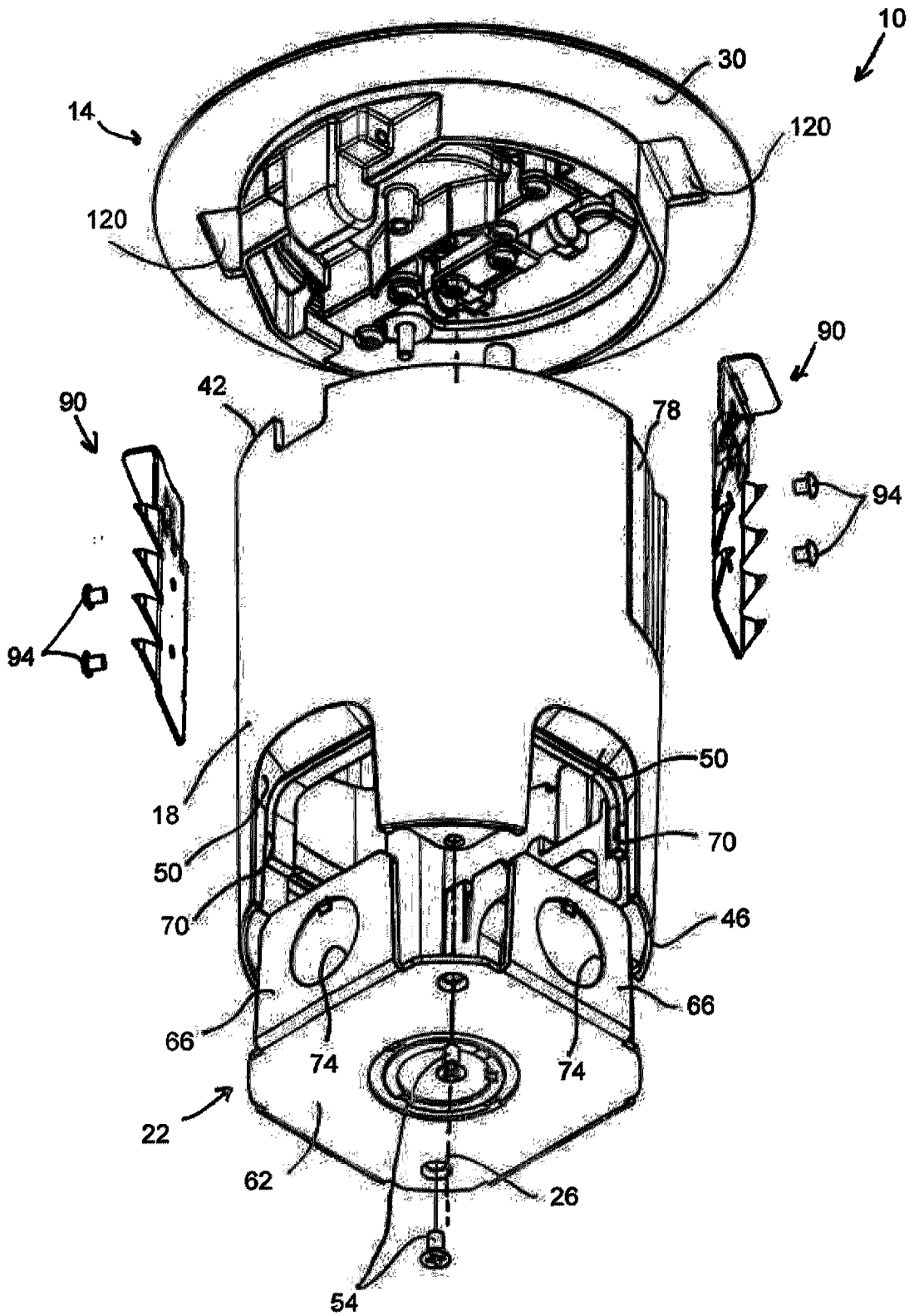

**FIG. 3**

FIG. 4

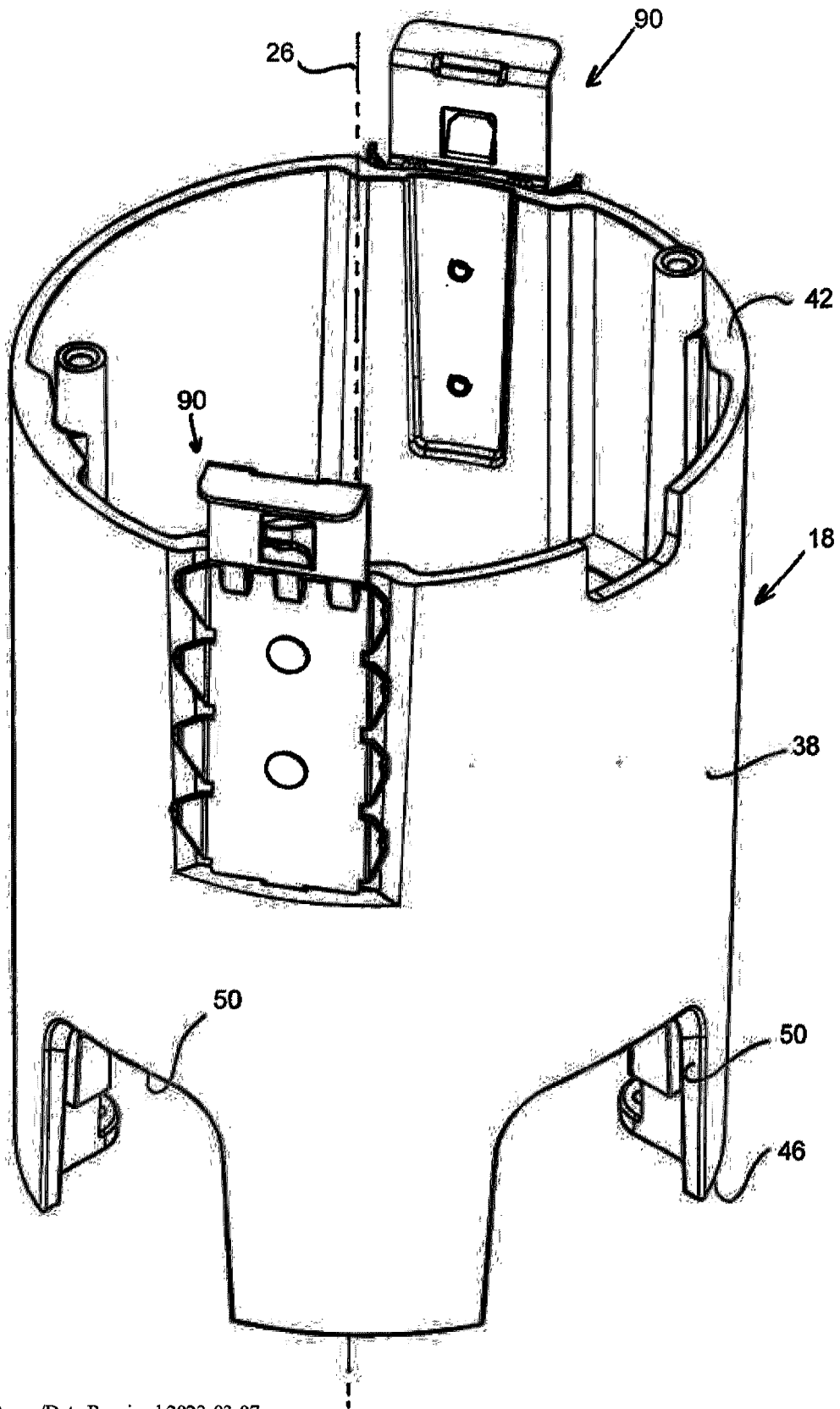
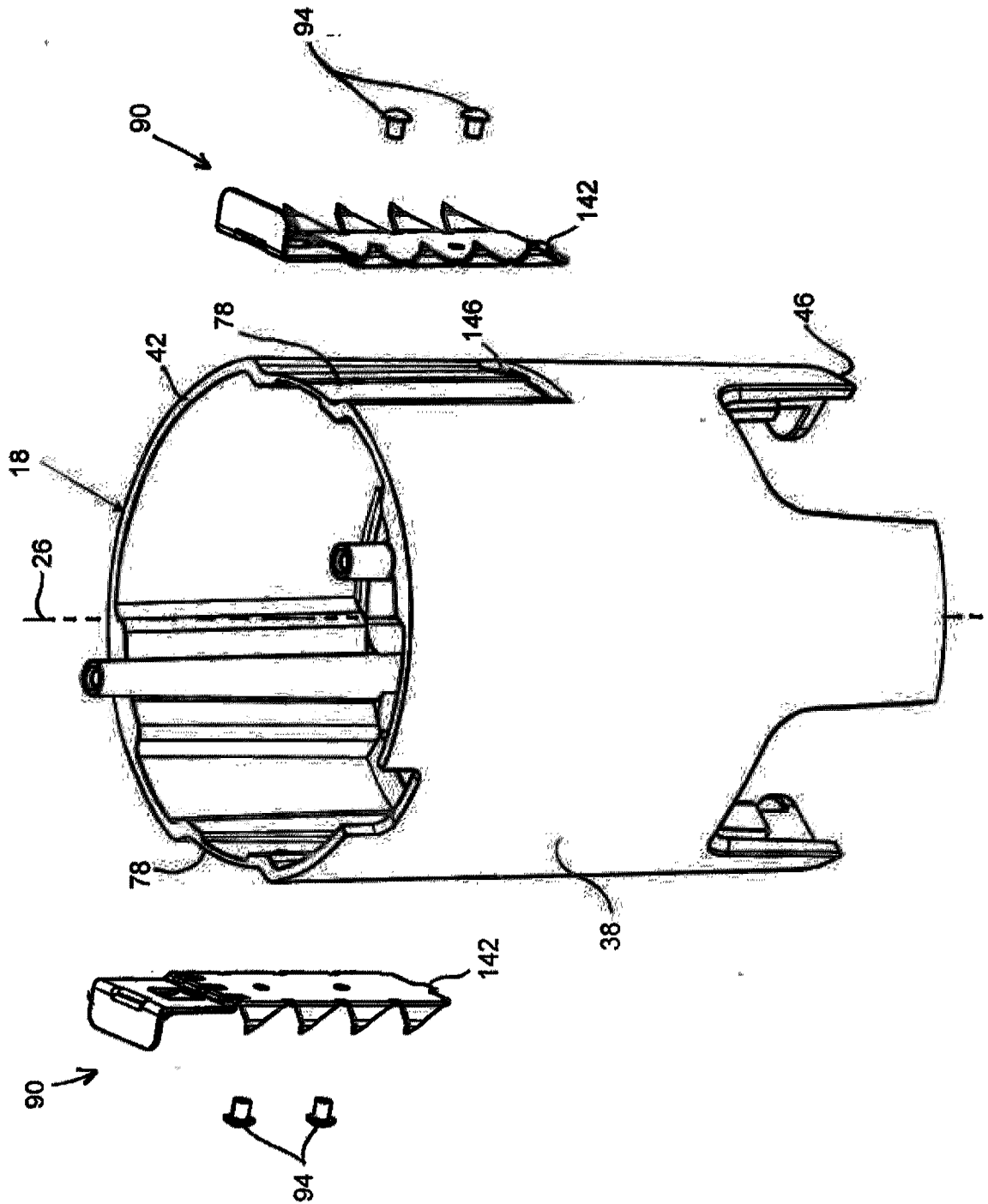
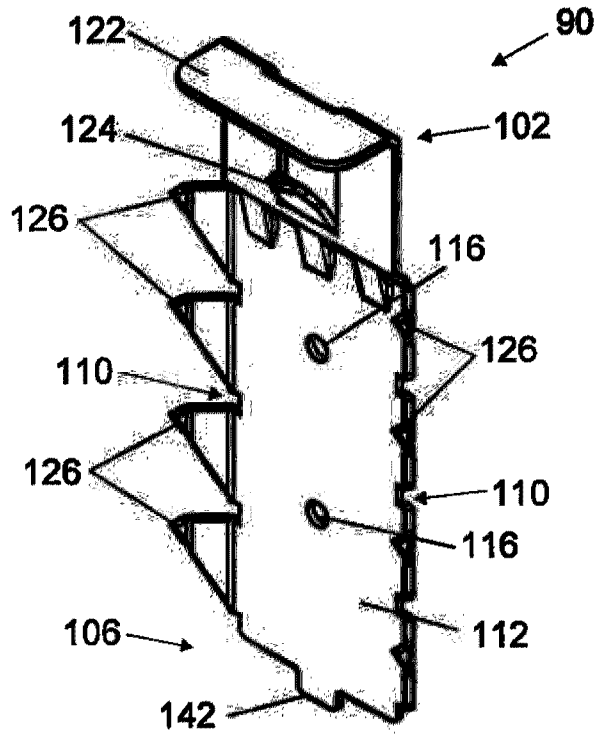
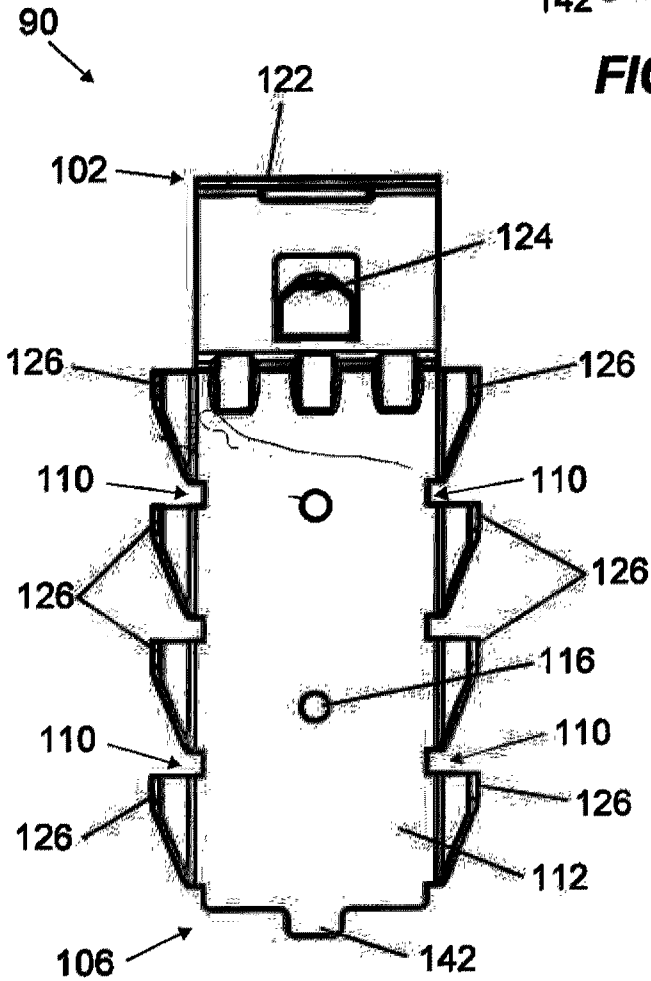

FIG. 5

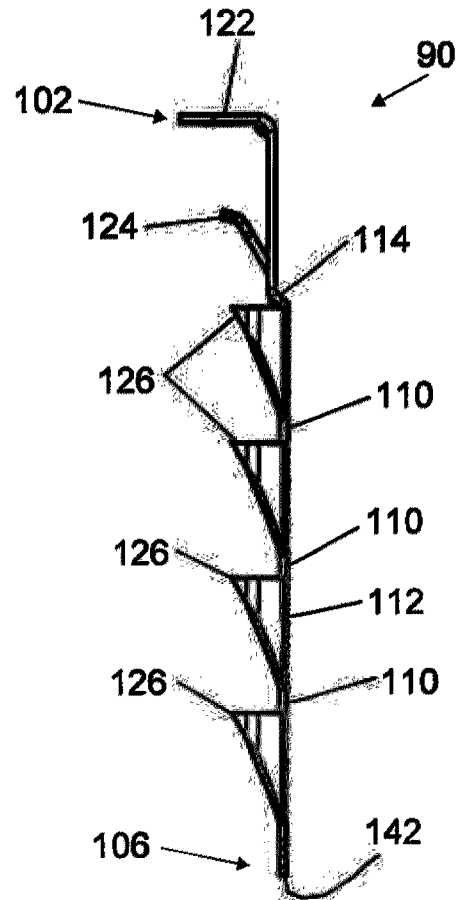



**FIG. 6**



**FIG. 7**



**FIG. 8**

