

[54] **FOLDING DEVICE FOR PACKAGING MACHINES**

3,520,103 7/1970 Stevens..... 53/378 X
 3,739,547 6/1973 Brevko et al. 53/182

[75] Inventor: **Karl-Ernst Timmerbeil**, Ennepetal, Germany

Primary Examiner—Travis S. McGehee
Assistant Examiner—Horace M. Culver
Attorney, Agent, or Firm—Ernest G. Montague; Karl F. Ross; Herbert Dubno

[73] Assignee: **Firma Packautomatic GmbH & Co. K.G.**, Ennepetal, Germany

[22] Filed: **Aug. 1, 1973**

[21] Appl. No.: **384,756**

[30] **Foreign Application Priority Data**

Aug. 2, 1972 Germany..... 2237948

[52] U.S. Cl..... **53/182, 53/378**

[51] Int. Cl..... **B65b 9/12, B65b 7/04**

[58] Field of Search 53/180, 182, 220, 226, 53/223, 229, 230, 381 R, 371, 374, 378, 379

[56] **References Cited**

UNITED STATES PATENTS

1,195,228	8/1916	Johnson	53/230
1,195,721	8/1916	Post	53/230
2,609,646	9/1952	Total	52/230
2,756,553	7/1956	Ferguson et al.	53/374 X
2,831,303	4/1958	Hollis	53/230 X

[57] **ABSTRACT**

A folding device on a packaging machine for wrapping goods in a foil comprises a device for feeding goods to be wrapped along a path and an arrangement for supplying a foil having lateral end portions and a front vertical foil portion as well as a rear end portion and an overhanging upper horizontal foil portion, toward the path, for wrapping around the goods. A device seals and cuts the foil during the feeding of the goods. A rigid first folding finger effects inward folding of a front vertical portion of the foil. A rear folding device includes a second folding finger for folding the rear end portion of the foil. The rear folding device includes a supporting finger, and a device for setting the supporting finger intermittently below the overhanging upper horizontal foil portion.

2 Claims, 8 Drawing Figures

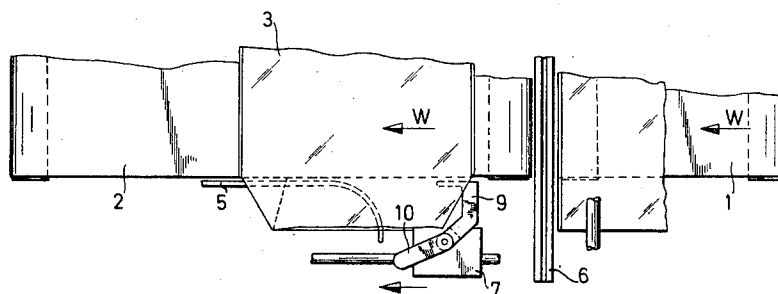

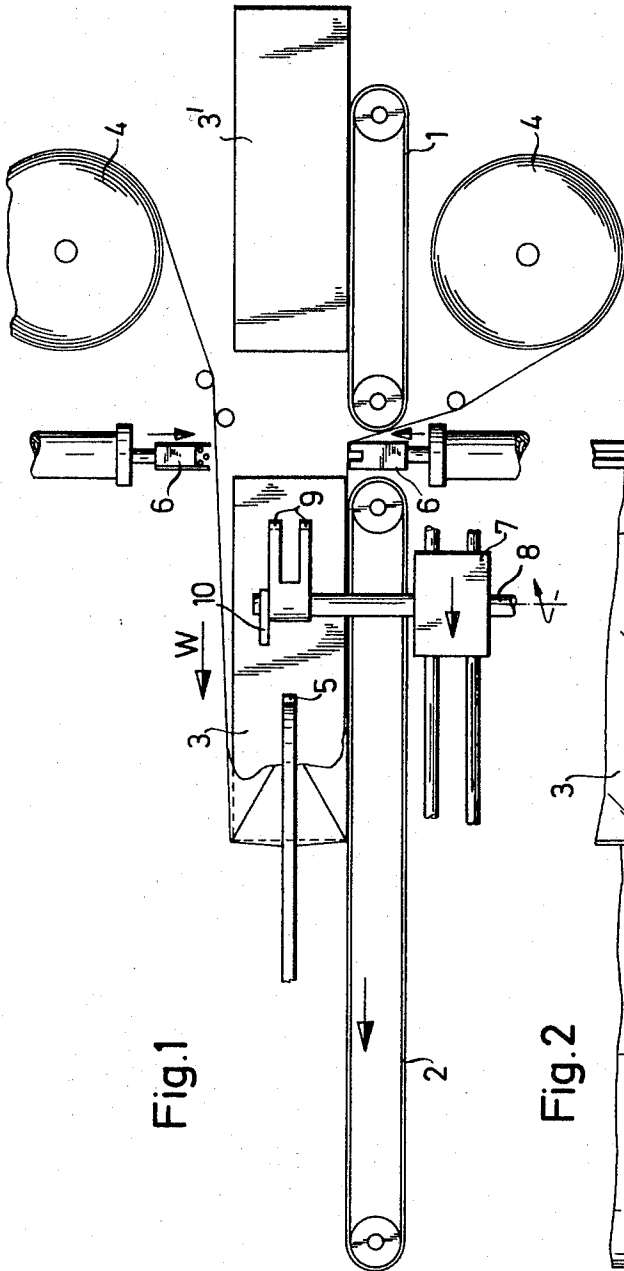

Fig.1

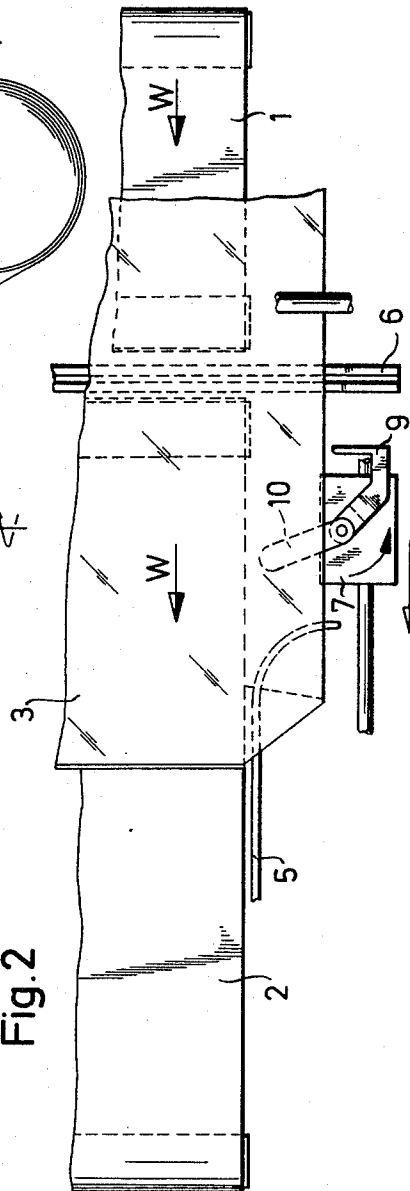

Fig.2

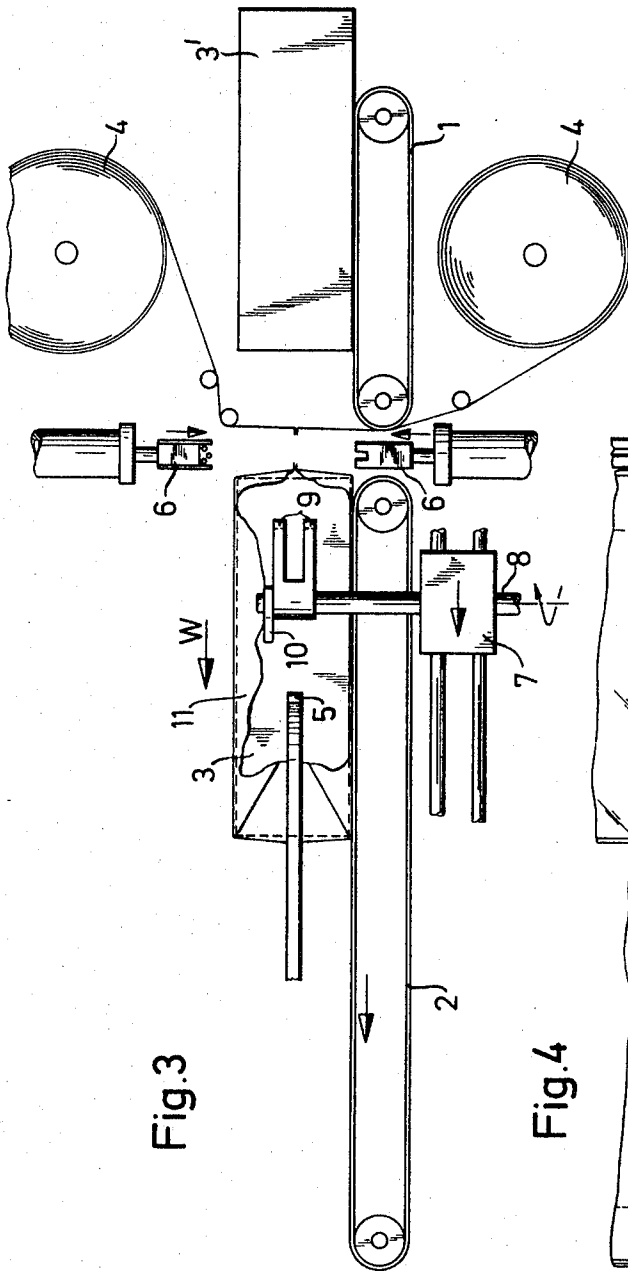

Fig.3

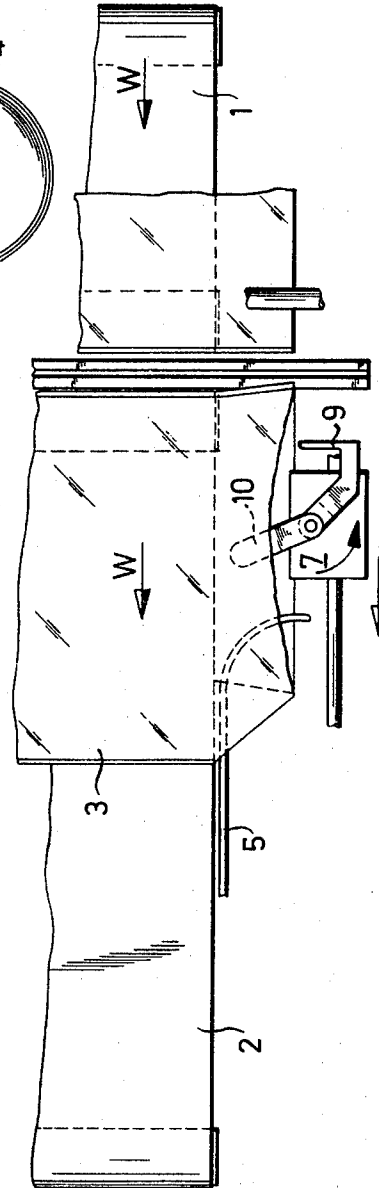

Fig.4

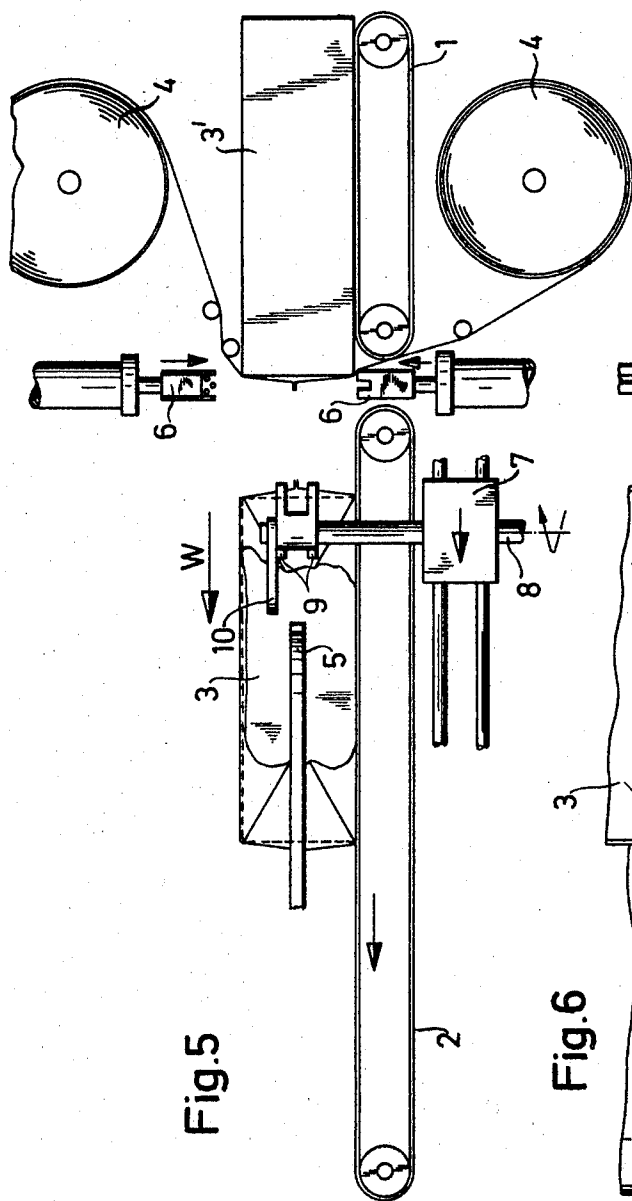

Fig. 5

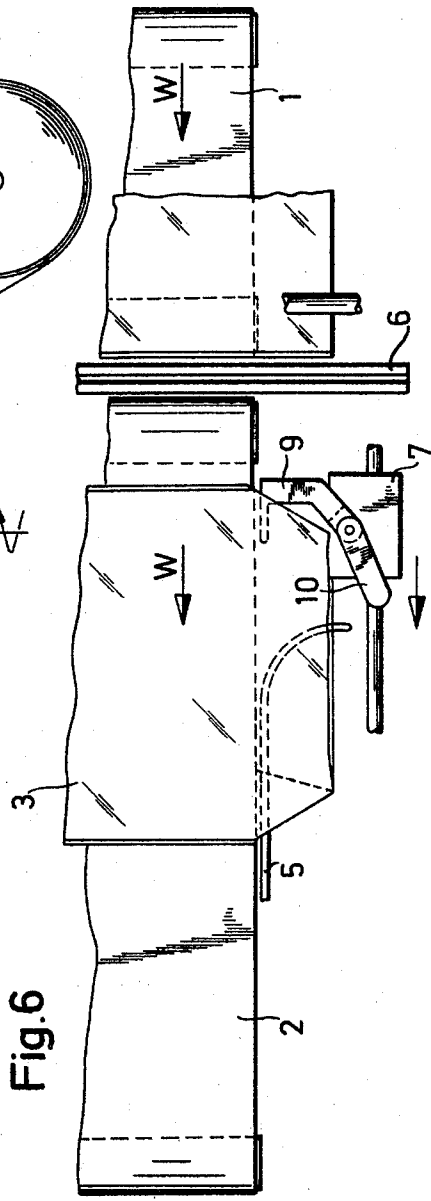

Fig. 6

Fig.7

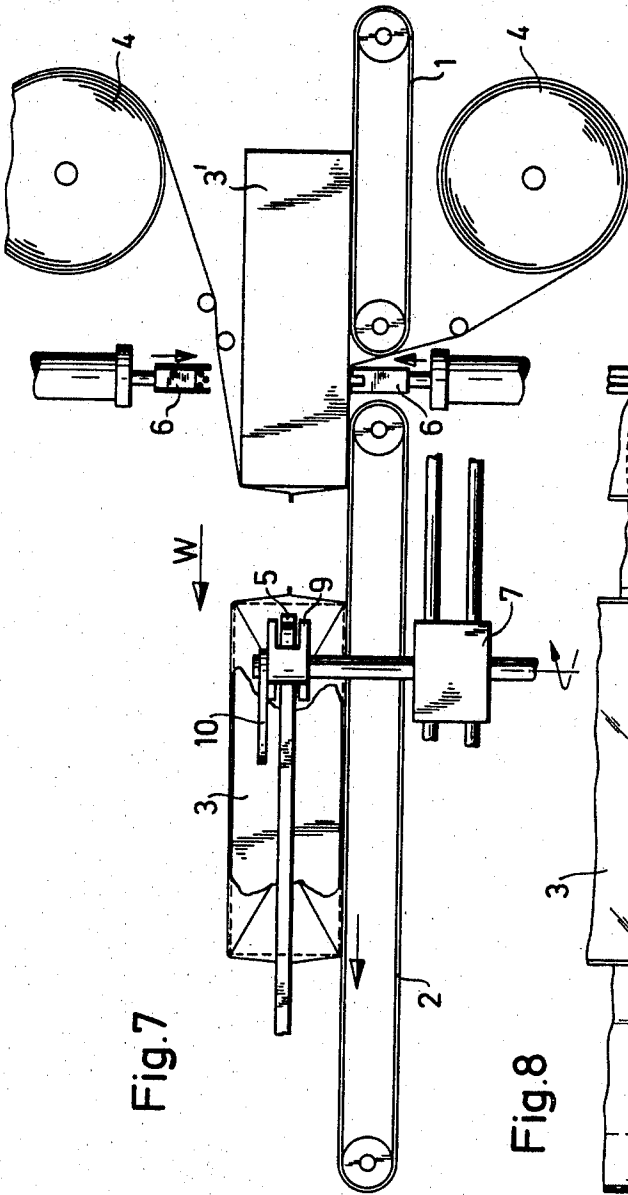
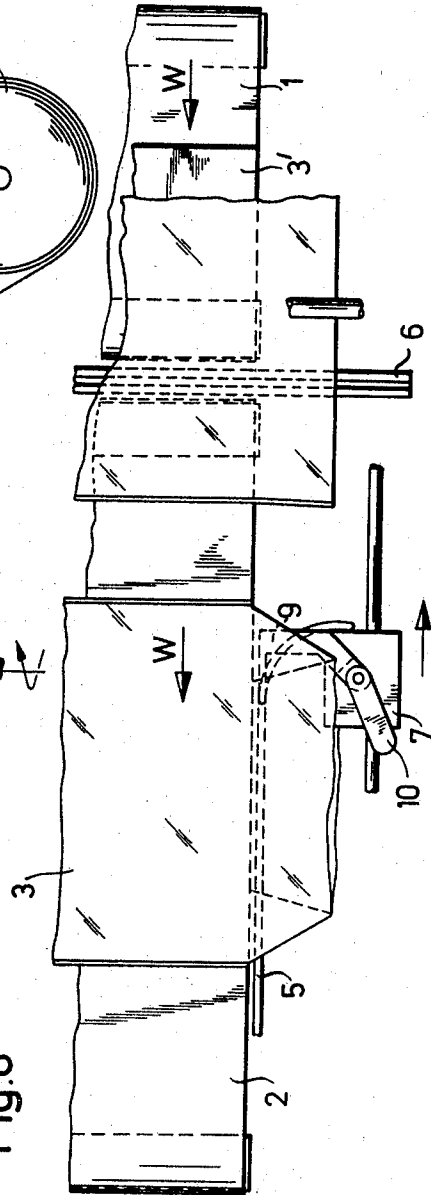

Fig.8



FOLDING DEVICE FOR PACKAGING MACHINES

The present invention relates to a folding device for a packaging machine, which wraps goods in foil and closes the ends by folding and gluing or heat-sealing, the folding inwards of the front vertical portion of the foil being effected by a rigid folding finger, while the rear end portion can be folded in by a rear folding device which travels along with the goods and is provided with a second folding finger.

Known foil packaging machines frequently form a wrap or sleeve, which protrudes at the side ends, around the goods. During a subsequent step the foil protruding at the ends is folded inwardly by folding device in such a manner that it rests snugly and neatly against the goods.

In known folding devices of the aforementioned type, the front vertical portion of the foil is folded by a stationary folding finger, past which the wrapped material passes, while the rear vertical portion of the foil is folded in by a second folding finger of a rear folding device, which travels along with the goods to be packed and leads the same somewhat. Thereupon the remaining upper and lower horizontal portions of the foil are folded over and the foil is then fixed by heat sealing or gluing in this position.

In order to obtain a complete closure of the ends of the package, the foil sleeve must protrude at the ends beyond the package to such an extent that an overlapping fold is possible. With an increase in the height or size of the goods, correspondingly more foil must therefore protrude at the ends. For a proper folding it is absolutely necessary that the protruding parts of the foil wrap extend as straight and as smoothly as possible since undulations, folds or sags in the foils prevent clean folding.

With increasing size of the package and thus increasing projection of the foil beyond the ends, the thickness of the foil and therefore its stiffness are not increased in the same proportion. As a result the cantilevered foil portions are unstable at the ends and therefore cannot be properly folded. In particular, the sagging of the upper horizontal portion of the foil warp presents a considerable problem. Thus it has already been attempted to prevent the sagging of the sheet by jets of air. The fluttering of the sheet which is unavoidable in this case, however, results in other serious disadvantages.

It is an object of the present invention to provide a folding device for a foil packaging machine which is capable of producing at all times a good, clean fold and which avoids the disadvantages and defects of the aforementioned apparatus.

According to the present invention, the folding device for a packaging machine has a rear folding device with a supporting finger which can be intermittently brought over the protruding upper horizontal portion of the foil wrap.

The present invention thus does away with the overhang of the upper foil parts, which interferes with the formation of a clean, dependable fold. The device acts intermittently, i.e., during a folding period in which the upper part of the foil is not as yet folded, since the front and rear ends are first folded inwardly. As soon as this has been done, the supporting finger releases the upper part of the foil for the final folding.

In practice, the folding finger of the rear folding device can be swingable about an axis perpendicular to the direction of transport of the goods from a position of rest outside the path of the foil into a position of action on the foil so that the folding finger and the supporting finger alternately act on the foil.

By the swingable arrangement of the folding finger of the rear folding device and the connection of the supporting finger with it, it is possible, with an extremely simple mechanism to ensure that the supporting finger always comes into engagement for as long as is necessary to prevent the sagging of the upper foil portion before the folding finger of the rear folding device can enter into action. As soon as the folding finger of the rear folding device swings around and folds inwardly the rear vertical portion of the foil, the supporting finger can release the upper horizontal portion of the foil for the final folding, whereby an extremely clean and precise folding is obtained.

The unit comprising the folding finger and the supporting finger can have a rotatable shaft with the folding finger and supporting finger firmly connected with it. Such a shaft is a structurally simple and economical drive means for the intermittently acting folding and supporting fingers.

The device of the invention is structurally simple and is capable, by intermittent support of sagging foil portions of producing a dependable clean fold even in the case of large packages with nonself-supporting foil wraps.

These and other objects will become more readily apparent from the following detailed description, reference being made to, the accompanying drawing, in which:

FIGS. 1, 3, 5 and 7 are schematic side elevations of the device of the present invention in different phases of the operation during a folding process; and

FIGS. 2, 4, 6 and 8 are the corresponding top plan views;

belts 1 and 2 of the packaging machine transport articles 3 to be wrapped in the direction indicated by the arrow W. The foil required for the packaging is drawn from foil-supply rolls 4. A heat-sealing device 6, consisting of two opposed members heat seals and cuts the two webs of foil behind the goods 3 and, at the same time, heat seals a seam at foil ends withdrawn from the rolls 4 and several from the package, so that a wrap is formed around the goods. The cut ends of the foils withdrawn from the rolls 4 are so heat sealed to each other that they form a curtain which can intercept the leading side of an oncoming article, as can be noted in particular from FIG. 3.

Behind the heat sealing device 6, as seen in the direction of the transport of the goods, there is located laterally alongside of the goods 3 a ski-shaped, rigid and fixed folding finger 5, which folds the front vertical portion of the overhanging foil corresponding against the end of the article. This rigid folding finger 5 is so arranged that the front vertical part of the sheet is folded inwards before the heat-sealing and cutting device 6 heat-seals and cuts the webs of foil unwound from the rolls 4.

Laterally adjacent the conveyor belts 1 and 2 there is arranged between the heat-sealing device 6 and the rigid folding finger 5 a rear folding device 7 to 10. The latter device includes a carriage 7 shiftable in the direction of transport of the goods (arrow W) and which

3

carries a shaft 8 rotatable as shown about a vertical axis perpendicular to the direction of displacement of the carriage and which forms the connection between the longitudinally displaceable carriage 7 and the swivable folding finger 9, and a supporting finger 10. Bifurcated folding finger 9, which straddles the finger 5, and supporting finger 10 are angularly offset on and are coupled with this shaft 8, so as to be entrained therewith in its rotation.

FIGS. 1 and 2 show the article 3 at a time just before the end of the formation of the sleeve. The article is located with its front face already in the region of the rigid folding finger 5, so that the front vertical foil portion is folded in, while the foil parts of the wrap are still connected with the supply rolls 4. The folding finger 9 is at this point located outside the path of the foil wrap, while the supporting finger 10 is already in its active position, underlying the upper portion.

After the heat sealing of the parts of the foil behind the goods 3, as shown in FIGS. 3 and 4, the foil sleeve is already separated from the rolls 4 and the tension under which the wrap was held previously, is no longer present, so that the upper horizontal portion 11 of the wrap tends to sag downward on the goods. This sagging horizontal portion 11 rests on the supporting finger 10, to provide room for the inward folding of the rear vertical portion of the foil.

The shaft 8 is then rotated and the fork-shaped movable folding finger 9, by swinging in the direction towards the goods 3, folds the rear part of the wrap inwards. As the goods continue to move, the entire rear-folding device moves via the carriage 7 in the direction of transport W of the goods, until the rear vertical portion which has been folded in by the folding finger 9 is located beneath the rigid folding finger 5, as shown in FIGS. 7 and 8. Simultaneously with the inward swinging of the folding finger 9, the supporting finger 10, which is coupled with the folding finger 9, so as to be carried along upon the swinging thereof, clears the upper horizontal portion 11 of the foil to enable it to fold downwardly.

While the goods 3 are transported further to the next processing station, where heat-sealing, gluing, labeling or the like take place, the entire rear folding device moves back via the carriage 7 into the starting position, shown in FIGS. 1 and 2, only when the front edge of the next article 3' is at the rigid folding finger 5. By the in-

4

ward folding of the front side of the wrap which then takes place, the folding finger 9, upon backward movement, can pass into the sleeve. After the starting position, shown in FIGS. 1 and 2, has been reached, the shaft 8 turns the folding finger 9 out of the wrap and the supporting finger 10 is at the same time turned into the next sleeve, after the heat-sealing of the wrap which then takes place, to support the upper horizontal portion of the next wrap. The process is then repeated in the manner described above.

I claim:

1. In a packaging machine for wrapping articles in a foil, the combination which comprises:

transport means for feeding said articles along a path; means for feeding a lower foil along the underside of said article and an upper foil along the upper side of said article with said foils laterally overhanging ends of the article;

means for sealing said foils together, thereby forming a sleeve with the overhanging portions of the foil including a vertical front portion, a horizontal upper portion and a vertical rear portion;

a fixed first folding finger disposed along said path and engageable with the vertical front portion of a sleeve wrapped around an article displaced along said path for folding said vertical front portion inwardly against the latter article;

a shaft disposed alongside said path and rotatable about an axis perpendicular to the direction of feed of said articles;

a supporting finger mounted on said shaft and swivable thereby into a position underlying said horizontal upper portion of said sleeve for supporting said horizontal upper portion against sagging; and

a second folding finger mounted on said shaft below said support finger and angularly offset therefrom which swings by said shaft into engagement with said rear vertical portion to fold the same inwardly against the article into a space maintained by the support of said horizontal upper portion by said support.

2. The combination defined in claim 1 wherein said second folding finger is bifurcated to straddle said first folding finger, said combination further comprising a carriage shiftable along said path and supporting said shaft.

* * * * *

50

55

60

65