

(12) INTERNATIONAL APPLICATION PUBLISHED UNDER THE PATENT COOPERATION TREATY (PCT)

(19) World Intellectual Property Organization
International Bureau



(43) International Publication Date
27 December 2002 (27.12.2002)

PCT

(10) International Publication Number
WO 02/102286 A1

- (51) International Patent Classification⁷: **A61F 2/46**
- (21) International Application Number: PCT/SE01/01345
- (22) International Filing Date: 14 June 2001 (14.06.2001)
- (25) Filing Language: English
- (26) Publication Language: English
- (71) Applicant (for all designated States except US): **CEM-VAC SYSTEM AB** [SE/SE]; Hackeforsvägen 1, S-589 41 Linköping (SE).
- (72) Inventor; and
- (75) Inventor/Applicant (for US only): **JONSSON, Sören** [SE/SE]; Rönnhagsvägen 38, S-589 41 Linköping (SE).
- (74) Agent: **WILLQUIST & PARTNERS PATENTBYRÅ AB**; Platensgatan 9C, S-582 20 Linköping (SE).
- (81) Designated States (national): AE, AG, AL, AM, AT, AU, AZ, BA, BB, BG, BR, BY, BZ, CA, CH, CN, CO, CR, CU, CZ, DE, DK, DM, DZ, EC, EE, ES, FI, GB, GD, GE, GH, GM, HR, HU, ID, IL, IN, IS, JP, KE, KG, KP, KR, KZ, LC, LK, LR, LS, LT, LU, LV, MA, MD, MG, MK, MN, MW, MX, MZ, NO, NZ, PL, PT, RO, RU, SD, SE, SG, SI, SK, SL, TJ, TM, TR, TT, TZ, UA, UG, US, UZ, VN, YU, ZA, ZW.
- (84) Designated States (regional): ARIPO patent (GH, GM, KE, LS, MW, MZ, SD, SL, SZ, TZ, UG, ZW), Eurasian patent (AM, AZ, BY, KG, KZ, MD, RU, TJ, TM), European patent (AT, BE, CH, CY, DE, DK, ES, FI, FR, GB, GR, IE, IT, LU, MC, NL, PT, SE, TR), OAPI patent (BF, BJ, CF, CG, CI, CM, GA, GN, GW, ML, MR, NE, SN, TD, TG).
- Published:**
— with international search report
- For two-letter codes and other abbreviations, refer to the "Guidance Notes on Codes and Abbreviations" appearing at the beginning of each regular issue of the PCT Gazette.*

(54) Title: METHOD AND DEVICE FOR PREPARATION OF BONE CEMENT

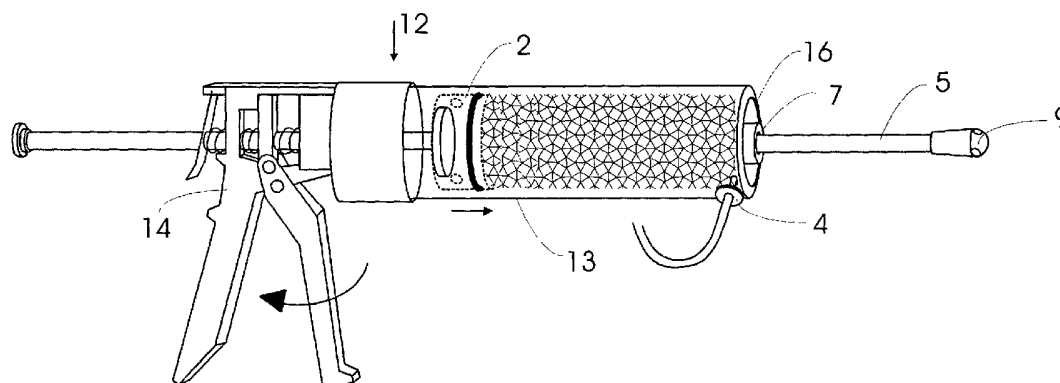

(57) Abstract: The present invention relates to a method and a device for preparation of bone cement. The constituent components of bone cement are mixed under vacuum in a closed mixing chamber, which has a vacuum connection (4), a moveable wall section (2), a device arranged to maintain the moveable wall section (2) in its initial position during the mixing process, an extrusion opening located opposite to the moveable wall section (2) and a device (9) arranged to openably seal the extrusion opening. The extrusion is performed by means of the moveable wall section (2) being brought to move towards the extrusion opening, by applying a force against the moveable wall section (2) by means of an extrusion tool (12). The present invention is characterized in that the moveable wall section (2) is set free after finished mixing and thereafter forced towards the extrusion opening for compression of bone cement while the extrusion opening is sealed by the sealing device (9).

WO 02/102286 A1

Method and device for preparation of bone cement

BACKGROUND OF THE INVENTION

The present invention relates to a method according to the preamble of claim 1.

5 The invention also relates to a device according to the preamble of claim 4.

When preparing bone cement it is important, considering the future strength of the bone cement, to achieve a bone cement which is as free as possible from pores and the like caused by air or gas inclusions. These inclusions may be caused by remain-
10 ing air and gases, occurring when mixing the components of the bone cement, which during the mixing procedure are mixed into the bone cement mass.

From SE-9200360-7 it is previously known how to collect dispersed bone cement, by means of the movement occurring under the influence of vacuum in the mixing
15 chamber when the movable wall section is set free, to form a bone cement pillar in the evacuation section of the mixing chamber. To prevent air, to the extent possible, from leaking in one or several O-rings are arranged around the movable wall section. The O-rings will cause an increased friction implying that the movement of the mov-
20 able section as well as the collection of bone cement thereby will be poor or prevented when the sealing causes too high friction. Consequently it can be stated, for known devices or methods for preparation of bone cement, that it must be accepted to allow some air or gas inclusions.

SUMMARY OF THE INVENTION

25 The object of the present invention is to produce improved removal of air and gas inclusions in the bone cement. In addition assurance is attained that the movable wall section always will be moved and that thereby improved collection of bone cement is obtained. This is achieved according to the method of the invention by means of the
30 measures indicated in the characterizing part of claim 1. A device for performing the method according to the invention bears the features indicated in the characterizing part of claim 4.

BRIEF DESCRIPTION OF THE DRAWING

In the following the invention will be explained in more detail by means of examples of embodiments of the present invention and with reference to the accompanying drawing.

5 Fig. 1a illustrates a mixing chamber, in accordance with the invention, during mixing of the constituent components of bone cement. In Figs. 1b-1e a number of phases are illustrated when the mixing chamber is introduced into a sleeve of an extrusion tool. Fig. 2a and Fig. 2b illustrate how the compression and extrusion procedures respectively are carried out by means of the extrusion tool. In Fig. 3 the movement of the
10 bone cement in the mixing chamber during the extrusion process is illustrated. Fig. 4a-4c illustrate three different embodiments, according to the invention, of a sleeve integral with said extrusion tool. In Fig. 5 the mixing chamber is illustrated introduced into an alternative embodiment of the sleeve designed with a cut-out.

15 In the drawing designation 1 indicates a mixing chamber and 2 a moveable wall section, which is detachably fixed in its initial position by means of a locking pin 3. The mixing chamber 1 is equipped with a vacuum connection 4 and an agitator device. The agitator device comprises of an agitator rod 5 with an axial extrusion channel for
20 bone cement and an agitator 6 arranged around the end of agitator rod 5 within mixing chamber 1. The agitator rod 5 and the mixing chamber 1 are for reasons, which will be apparent later, preferably made from a transparent material.

The agitator rod 5 is axially moveable in mixing chamber 1 through opening 7 which is sealed against agitator rod 5. The orifice of the channel of agitator rod 5, in mixing
25 chamber 1, forms an extrusion opening 8 for bone cement at agitator 6. During mixing a sealing rod 9 is inserted into the channel of agitator rod 5 to seal extrusion opening 8. Flow line 10 illustrates the path of the bone cement during compression and extrusion processes at which the bone cement passes a filter 11 arranged in connection with vacuum connection 4.

30 The device according to the invention also comprises an extrusion tool 12 with a sleeve 13a and an extrusion pistol 14. Sleeve 13a is formed with an opening 15 for introduction of mixing chamber 1, an opening 16 for agitator rod 5, two grooves 17 for locking pin 3 and an opening 18 for vacuum connection 4.

35

DESCRIPTION OF THE INVENTION

Mixing chamber 1 is, when preparing bone cement, used to mix the constituent cement components under vacuum. The bone cement components are introduced into mixing chamber 1 after which agitator rod 5 of the agitator device, is axially moved in and out of mixing chamber 1, and preferably turned at the same time through opening 7. The actual mixing is performed by agitator 6, arranged around the end of agitator rod 5 within mixing chamber 1, since it is turned and moved among the bone cement components by means of the previously mentioned movement of agitator rod 5. During the entire mixing process extrusion opening 8 in association with the agitator 6 will come into contact with the bone cement. Leakage of bone cement out of and air into mixing chamber 1 via extrusion opening 8 is prevented during mixing by sealing rod 9.

When it is established that the bone cement components are sufficiently mixed the device is prepared for bone cement extrusion. The agitator rod 5 is then moved out of mixing chamber 1 as far as possible at which agitator 6 and extrusion opening 8 connect to the wall, located opposite to the moveable wall section 2 of mixing chamber 1. The extrusion process, wherein the bone cement is moved out of mixing chamber 1 through extrusion opening 8 and into the channel of agitator rod 5 functioning thereby as a nozzle, may then start.

Compression of the bone cement is, according to the present invention, performed before extrusion. The object with the compression is to squeeze remaining air and gas inclusions out of said bone cement to achieve as compact a material as possible. Both compression and extrusion are performed by means of extrusion tool 12, which is similar to a spray pistol for sealing compounds or similar, and sleeve 13a, in which mixing chamber 1 is placed after finished mixing.

Mixing chamber 1 is inserted into sleeve 13a through opening 15 and placed inside sleeve 13a such that agitator rod 5, when completely pulled out, is sticking out of sleeve 13a through opening 16. Sleeve 13a is formed with grooves 17 to keep locking pin 3, and thus the movable wall section 2, in its initial position during the insertion. The side wall of sleeve 13a is formed such that vacuum connection 4 has to be removed before insertion, however opening 18 allows for reconnection of vacuum connection 4 after insertion. The phases in relation to insertion of mixing chamber 1 into sleeve 13a are illustrated in Fig. 1b-e.

When mixing chamber 1 is placed inside sleeve 13a of extrusion tool 12, vacuum connection 4 is reconnected and the moveable wall section is set free by means of the locking pin 3 being removed. These phases are illustrated in Fig. 1d-e. The extrusion pistol 14 of extrusion tool 12 is thereafter connected to sleeve 13a and the actual
5 compression of the bone cement may start.

The compression, which also is performed under vacuum, is executed by a force applied by means of extrusion pistol 14, against the moveable wall section 2 such that it is moved towards extrusion opening 8. The bone cement will then move along the
10 flow lines 10, illustrated in Fig. 3, and be compressed towards extrusion opening 8. Passing towards extrusion opening 8 the bone cement will come into contact with filter 11 while air and gas inclusions are exhausted by suction through vacuum connection 4. After compression to a certain degree the bone cement will push sealing rod 9, which seals extrusion opening 8, ahead of the bone cement and out of the
15 channel of agitator rod 5, in which bone cement in the shape of a column is formed. When desired length of the bone cement column is obtained, agitator rod 5 is cut off at the front of the obtained bone cement column just at or ahead of the sealing rod 9. The extrusion and application of the bone cement may then be performed. Fig. 2a and 2b illustrate the compression and extrusion processes while mixing chamber 1 is
20 placed inside sleeve 13a and connected to extrusion pistol 14.

The present invention also comprises two alternative embodiments, 13b and 13c, of the sleeve of extrusion tool 12, these are illustrated in Fig. 4b and 4c.

25 In the sidewall of sleeve 13b a groove 17 and a cut-out 19 are formed. The cut-out 19 extends along most of the wall of sleeve 13b, with the aim to prevent the vacuum connection 4 from having to be removed before the insertion of mixing chamber 1. The vacuum connection 4 may thereby be kept during mixing, subsequent compression and extrusion processes, which are similar to the process described in relation to sleeve 13a. Furthermore the cut-out 19 and the groove 17 imply that the locking pin
30 3 may be kept during the insertion too. Fig. 5 illustrates the mixing chamber 1 inserted into sleeve 13b.

Sleeve 13c is formed without any groove or cut-out in the side wall, which means
35 that this sleeve is used when both vacuum connection 4 and locking pin 3 are removed before the insertion of mixing chamber 1. However, sleeve 13c is formed with an opening 18 in order to allow vacuum connection 4 to be reconnected prior to

subsequent compression and extrusion processes, which are performed in the same way as when sleeve 13a or 13b is used.

5 Common factors for the three sleeves 13a-c according to the invention, are that their interior is formed such that it is adjusted to the form of mixing chamber 1, this by having opening 15 for insertion of mixing chamber 1 and opening 16 for agitator rod 5, and that anyone of them may be used for an extrusion process performed under vacuum. However, the three sleeves 13a-c differ from each other in whether they
10 allow vacuum connection 4 and locking pin 3 to be kept in place during insertion of the mixing chamber 1, which will result in differing influences on the moveable wall section 2 in the process after insertion.

A negative pressure will arise in the mixing chamber 1 when the vacuum connection 4 is connected. This implies that the moveable wall section 2 will be influenced of
15 the vacuum to be sucked into the mixing chamber 1. If the moveable wall section 2 is set free when vacuum connection 4 is connected, which is the case at reconnection of the vacuum connection 4 after insertion of the mixing chamber 1 into sleeve 13c, the moveable wall section 2 will be sucked into the mixing chamber 1. When the mixing chamber 1 is placed in sleeve 13a or 13b the moveable wall section 2 is, despite the
20 influence of the vacuum, kept in its initial position by the locking pin 3 and can therefore not be moved before removing locking pin 3.

It is apparent, for anyone skilled in the art, that the present invention is not restricted
25 to the above-described embodiments. For example extrusion may also be performed by means of an extrusion tool assuming other embodiments than mentioned above.

CLAIMS

1. A method for preparation of bone cement, the constituent components of which are mixed under vacuum in a closed mixing chamber (1), which is formed with a moveable, during the mixing process detachably fixed, wall section (2), the extrusion of bone cement being performed by means of the moveable wall section (2) being brought to move towards an extrusion opening (8),
5 c h a r a c t e r i z e d in that after finished mixing the moveable wall section (2) is set free and thereafter with sealed extrusion opening (8) forced towards the extrusion opening (8) for compression of the bone cement.
- 10 2. A method according to claim 1, c h a r a c t e r i z e d in that the compression of the bone cement is performed under maintained vacuum in the mixing chamber (1).
- 15 3. A method according to claim 1 or 2, c h a r a c t e r i z e d in that after compression of the bone cement to a certain degree a sealing device (9) arranged within extrusion nozzle (5) to seal the extrusion opening (8) is pushed ahead of the bone cement and in direction out of the extrusion nozzle (5), in which a column of bone cement is formed under continued compression and that when a desired length of the column is formed, the compression is terminated and the
20 extrusion nozzle (5) is cut off just ahead of the front of the column of bone cement.
- 25 4. A method according to claim 1, c h a r a c t e r i z e d in that the extrusion of the bone cement is performed under maintained vacuum in the mixing chamber (1).
- 30 5. A device for performance of the method according to claim 1 comprising a mixing chamber (1) equipped with a vacuum connection (4), having a wall section (2) movable in the direction of the opposite part of the mixing chamber (1) and a device (3) arranged to maintain the moveable wall section (2) in its initial position during the mixing process, an extrusion opening (8) located opposite to the moveable wall section (2) of the mixing chamber (1) and a sealing device (9) arranged to openably seal the extrusion opening (8) and an extrusion tool (12), arranged to apply a force towards the moveable wall section (2) to
35 perform the extrusion, c h a r a c t e r i z e d in that the extrusion opening (8) is

sealed by means of said device (9) for compression of the bone cement before extrusion.

- 5 6. A device according to claim 5, characterized in that a first kind of sleeve (13a), which is part of the extrusion tool (12) has two grooves (17) formed to allow for maintaining the device (3), arranged to keep the moveable wall section (2) in its initial position, during insertion of the mixing chamber (1) into the sleeve (13a) and an opening (18) arranged to allow for the vacuum connection (4) to be reconnected to the mixing chamber (1) after insertion.
- 10 7. A device according to claim 5, characterized in that a second kind of sleeve (13b), which is part of the extrusion tool (12) has a cut-out (19) formed to allow for maintaining the vacuum connection (4) during the insertion of the mixing chamber (1) into the sleeve (13b) and a groove (17) formed to in conjunction with the cut-out (19) allow for maintaining the device (3) arranged to keep the moveable wall section (2) in its initial position during the insertion of the mixing chamber (1) into the sleeve (13b).
- 15 8. A device according to claim 5, characterized in that a third kind of sleeve (13c), which is part of the extrusion tool (12) has a an opening (18) arranged to allow for the vacuum connection (4) to be reconnected to the mixing chamber (1) after insertion of the mixing chamber (1) into the sleeve (13c).
- 20

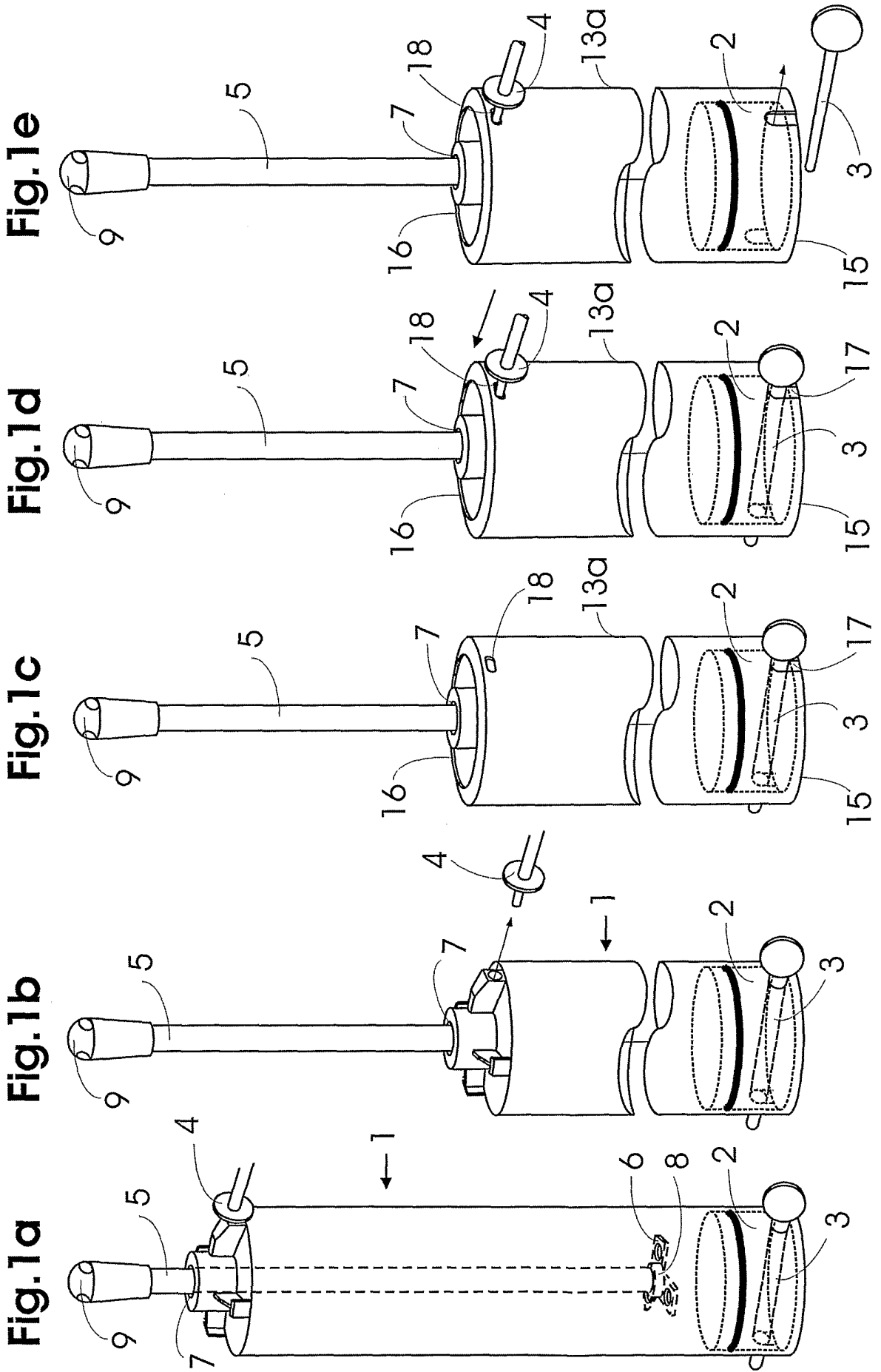

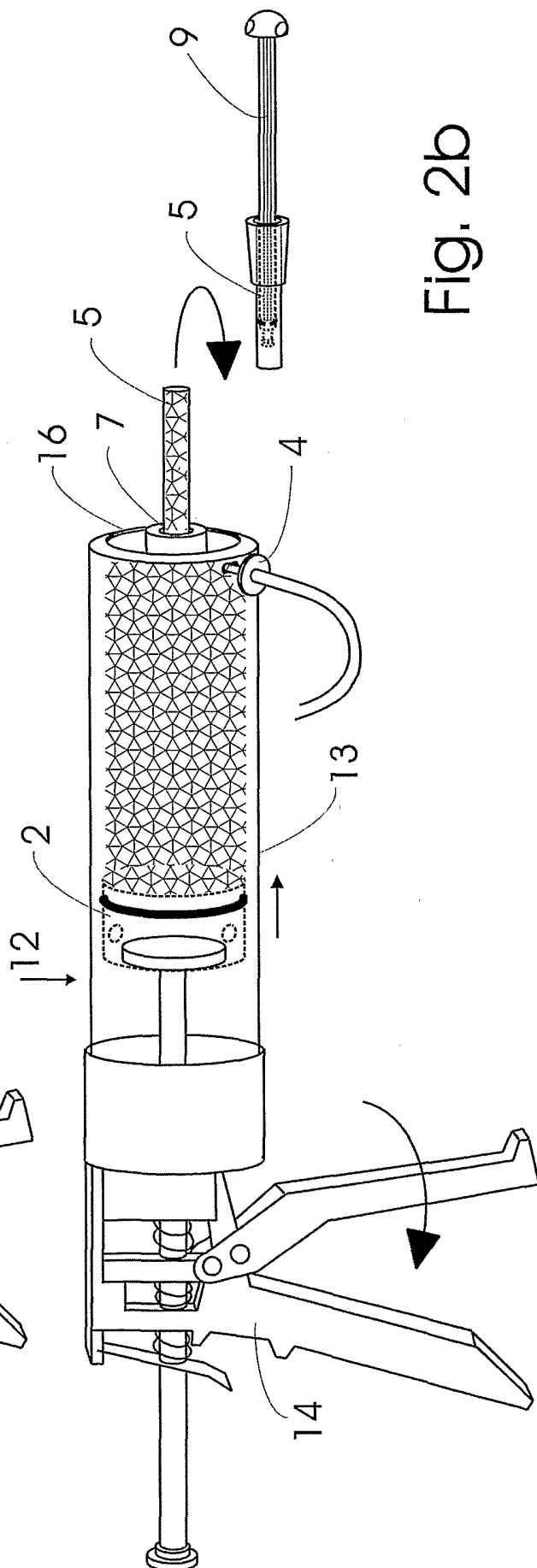
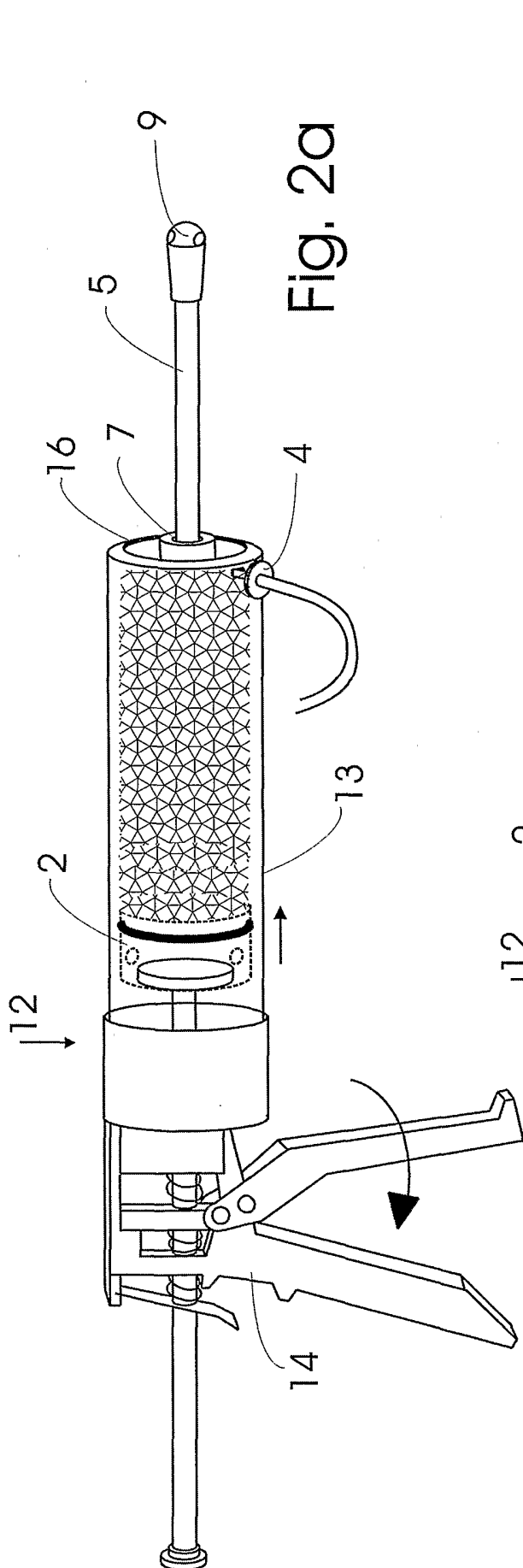

Fig 3

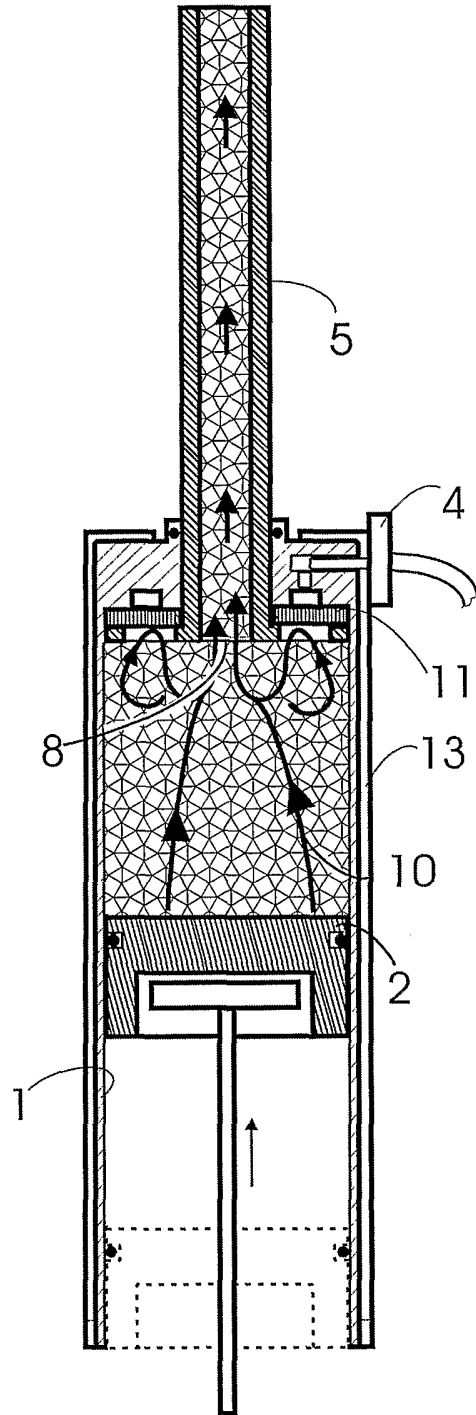

Fig.4a

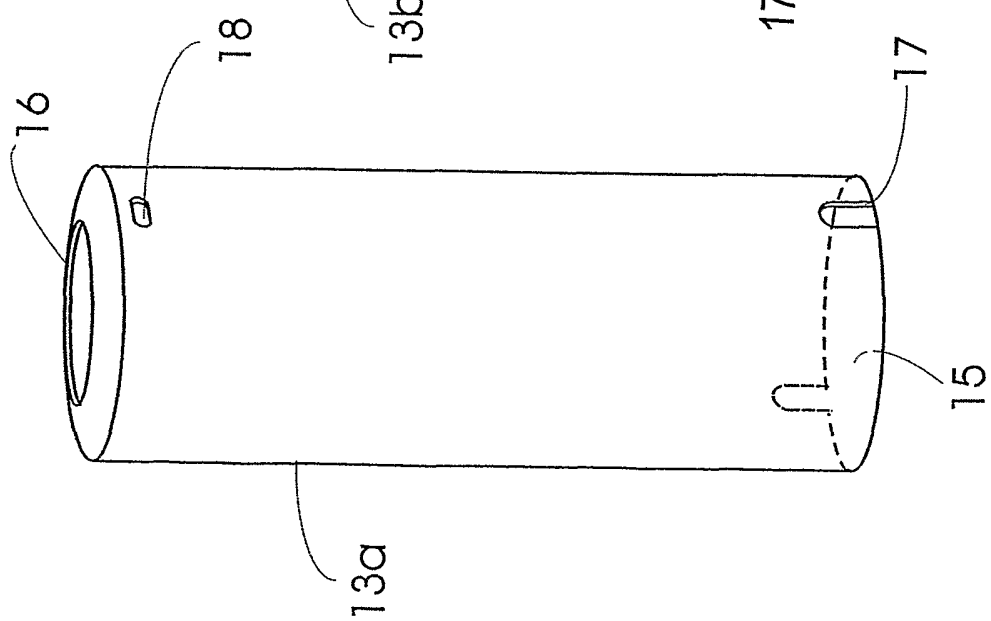

Fig.4b

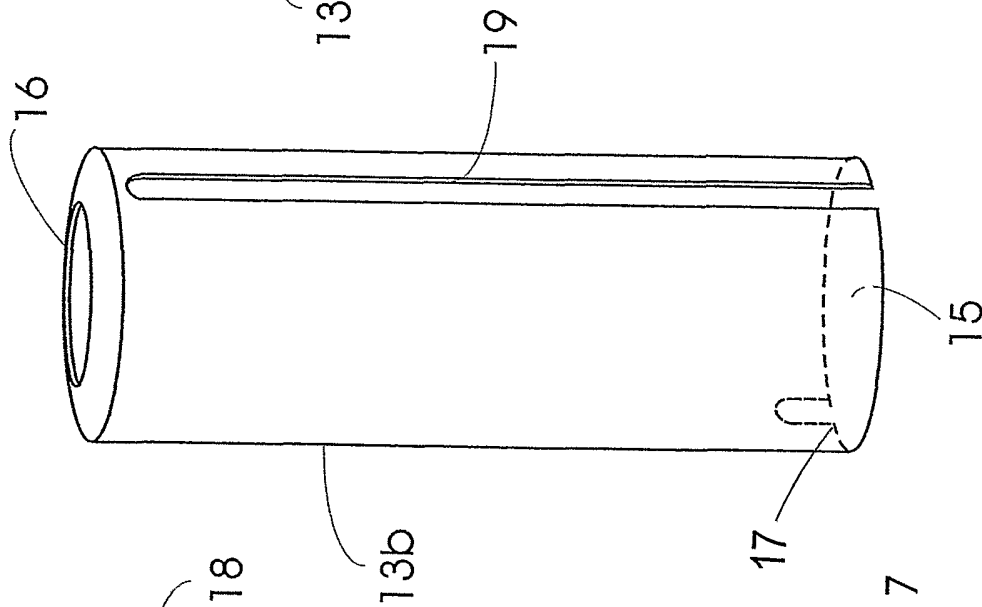

Fig.4c

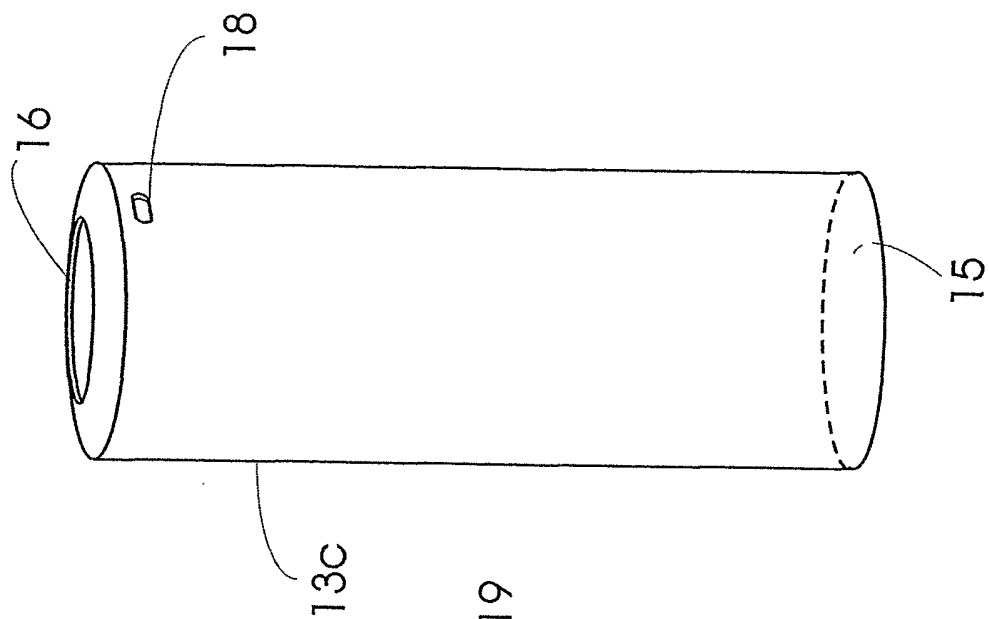
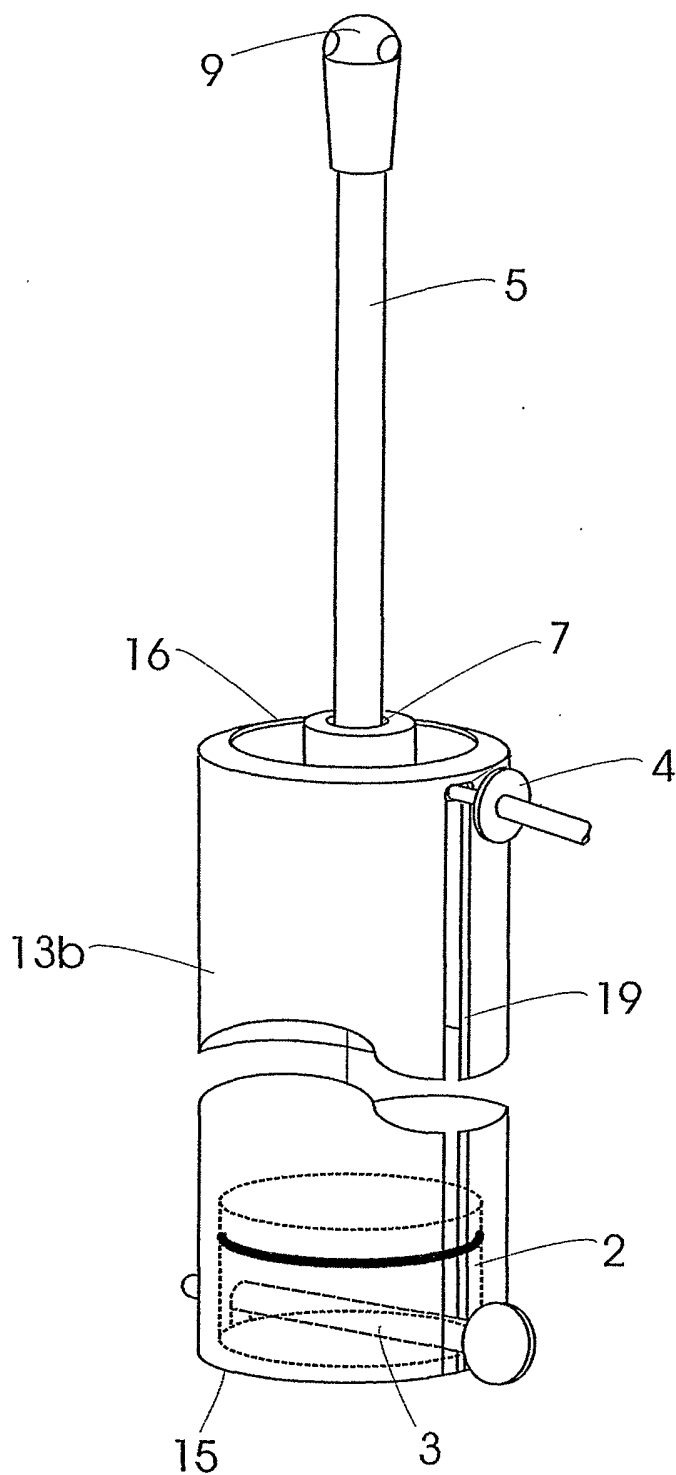

Fig.5



INTERNATIONAL SEARCH REPORT

International application No.

PCT/SE 01/01345

A. CLASSIFICATION OF SUBJECT MATTER

IPC7: A61F 2/46

According to International Patent Classification (IPC) or to both national classification and IPC

B. FIELDS SEARCHED

Minimum documentation searched (classification system followed by classification symbols)

IPC7: A61F, B01F

Documentation searched other than minimum documentation to the extent that such documents are included in the fields searched

SE,DK,FI,NO classes as above

Electronic data base consulted during the international search (name of data base and, where practicable, search terms used)

WPI DATA, EPO-INTERNAL

C. DOCUMENTS CONSIDERED TO BE RELEVANT

Category*	Citation of document, with indication, where appropriate, of the relevant passages	Relevant to claim No.
X	US 5328262 A (LARS A. A. LIDGREN ET AL), 12 July 1994 (12.07.94), figure 5, claims 1,4,5 --	1,2,5
X	US 4966601 A (KLAUS DRAENERT), 30 October 1990 (30.10.90), column 4, line 10 - line 13, claim 1 figure 2 --	1,2,5 6-8
X	US 5193907 A (GIOVANNI FACCIOLI ET AL), 16 March 1993 (16.03.93), column 6, line 9 - line 13, figure 5, abstract --	1,2,4,5

 Further documents are listed in the continuation of Box C. See patent family annex.

* Special categories of cited documents:

"A" document defining the general state of the art which is not considered to be of particular relevance

"E" earlier application or patent but published on or after the international filing date

"L" document which may throw doubts on priority claim(s) or which is cited to establish the publication date of another citation or other special reason (as specified)

"O" document referring to an oral disclosure, use, exhibition or other means

"P" document published prior to the international filing date but later than the priority date claimed

"T" later document published after the international filing date or priority date and not in conflict with the application but cited to understand the principle or theory underlying the invention

"X" document of particular relevance: the claimed invention cannot be considered novel or cannot be considered to involve an inventive step when the document is taken alone

"Y" document of particular relevance: the claimed invention cannot be considered to involve an inventive step when the document is combined with one or more other such documents, such combination being obvious to a person skilled in the art

"&" document member of the same patent family

Date of the actual completion of the international search

Date of mailing of the international search report

6 February 2002

07-02-2002

Name and mailing address of the ISA/
Swedish Patent Office
Box 5055, S-102 42 STOCKHOLM
Facsimile No. +46 8 666 02 86

Authorized officer

Mårten Hulthén/EI
Telephone No. +46 8 782 25 00

INTERNATIONAL SEARCH REPORT

International application No.

PCT/SE 01/01345

C (Continuation). DOCUMENTS CONSIDERED TO BE RELEVANT		
Category*	Citation of document, with indication, where appropriate, of the relevant passages	Relevant to claim No.
X	US 5549380 A (LARS Å A. LIDGREN ET AL), 27 August 1996 (27.08.96), column 4, line 55 - line 61, figure 6, abstract --	1,2,5
X	US 5100241 A (KWAN-HO CHAN), 31 March 1992 (31.03.92), figure 1	1
A	column 13, line 67 - column 14, line 26 --	3
A	US 4463875 A (SLOBODAN TEPIC), 7 August 1984 (07.08.84), column 4, line 45 - line 48, abstract --	1-3,5
A	WO 9967015 A1 (NIKOMED APS), 29 December 1999 (29.12.99), figure 6 -- -----	6-8

INTERNATIONAL SEARCH REPORT

International application No.
PCT/SE01/01345

Box I Observations where certain claims were found unsearchable (Continuation of item 1 of first sheet)

This international search report has not been established in respect of certain claims under Article 17(2)(a) for the following reasons:

1. Claims Nos.:
because they relate to subject matter not required to be searched by this Authority, namely:

2. Claims Nos.:
because they relate to parts of the international application that do not comply with the prescribed requirements to such an extent that no meaningful international search can be carried out, specifically:

3. Claims Nos.:
because they are dependent claims and are not drafted in accordance with the second and third sentences of Rule 6.4(a).

Box II Observations where unity of invention is lacking (Continuation of item 2 of first sheet)

This International Searching Authority found multiple inventions in this international application, as follows:

see next page

1. As all required additional search fees were timely paid by the applicant, this international search report covers all searchable claims.
2. As all searchable claims could be searched without effort justifying an additional fee, this Authority did not invite payment of any additional fee.
3. As only some of the required additional search fees were timely paid by the applicant, this international search report covers only those claims for which fees were paid, specifically claims Nos.:

4. No required additional search fees were timely paid by the applicant. Consequently, this international search report is restricted to the invention first mentioned in the claims; it is covered by claims Nos.:

Remark on Protest

- The additional search fees were accompanied by the applicant's protest.
 No protest accompanied the payment of additional search fees.

INTERNATIONAL SEARCH REPORT

Information on patent family members

International application No.

27/12/02

PCT/SE 01/01345

Patent document cited in search report	Publication date	Patent family member(s)	Publication date
US 5328262 A	12/07/94	DE 4302230 A,C	12/08/93
		JP 6510359 T	17/11/94
		SE 510490 C	31/05/99
		SE 9200360 A	08/08/93
		US 5423184 A	13/06/95
		US 5501520 A	26/03/96
US 4966601 A	30/10/90	AT 65689 T	15/08/91
		AT 89993 T	15/06/93
		AT 180656 T	15/06/99
		DE 3609672 A	24/09/87
		DE 3752279 D	00/00/00
		DE 3771820 D	00/00/00
		DE 3786049 D	00/00/00
		EP 0261182 A,B	30/03/88
		SE 0261182 T3	
		EP 0262185 A,B	06/04/88
		SE 0262185 T3	
		EP 0493363 A,B	01/07/92
		SE 0493363 T3	
		JP 2537530 B	25/09/96
		JP 7075613 B	16/08/95
		JP 63502882 T	27/10/88
		JP 63502883 T	27/10/88
US 5015101 A	14/05/91		
WO 8705491 A	24/09/87		
WO 8705492 A	24/09/87		
US 5193907 A	16/03/93	CA 2031434 A,C	30/06/91
		DE 4030832 A,C	11/07/91
		ES 2030614 A	01/11/92
		FR 2656521 A,B	05/07/91
		GB 2239818 A,B	17/07/91
		GB 9023587 D	00/00/00
		IT 1236864 B	22/04/93
		IT 8985010 D	00/00/00
		JP 6261932 A	20/09/94
		JP 8017781 B	28/02/96
		US 5435645 A	25/07/95

INTERNATIONAL SEARCH REPORT
Information on patent family members

27/12/02

International application No.

PCT/SE 01/01345

Patent document cited in search report			Publication date	Patent family member(s)		Publication date
US	5549380	A	27/08/96	DE	4409610 A,C,R	28/09/95
				DK	674888 T	25/09/00
				EP	0674888 A,B	04/10/95
				SE	0674888 T3	
				JP	8057284 A	05/03/96

US	5100241	A	31/03/92	CA	2041300 A	13/03/92
				AU	627513 B	27/08/92
				AU	4398289 A	19/07/90
				CA	2001998 A	13/07/90
				DE	68928257 D	00/00/00
				EP	0380867 A,B	08/08/90
				SE	0380867 T3	
				ES	2108683 T	01/01/98
				JP	2901192 B	07/06/99
				US	RE35276 E	18/06/96
US	4973168 A	27/11/90				

US	4463875	A	07/08/84	AT	50137 T	15/02/90
				DE	3481272 D	00/00/00
				EP	0179054 A,B	30/04/86
				WO	8504567 A	24/10/85

WO	9967015	A1	29/12/99	AU	7425598 A	10/01/00
				EP	1035909 A	20/09/00
