



(12) **EUROPEAN PATENT APPLICATION**

(88) Date of publication A3:
19.07.2000 Bulletin 2000/29

(51) Int Cl.7: **B26D 7/22, F16P 1/02**

(43) Date of publication A2:
29.09.1999 Bulletin 1999/39

(21) Application number: **99302137.7**

(22) Date of filing: **19.03.1999**

(84) Designated Contracting States:
**AT BE CH CY DE DK ES FI FR GB GR IE IT LI LU
 MC NL PT SE**
 Designated Extension States:
AL LT LV MK RO SI

(72) Inventor: **Porter, Brian
 Sutton-Ashfield
 Nottinghamshire NG17 4LB (GB)**

(30) Priority: **24.03.1998 GB 9806148**

(74) Representative: **Chugg, David John et al
 Appleyard Lees,
 15 Clare Road
 Halifax, West Yorkshire HX1 2HY (GB)**

(71) Applicant: **Staples Group PLC
 Huddersfield, West Yorkshire (GB)**

(54) **Cutting machine blade guard**

(57) A band knife guard (10) comprises upper, middle and lower guard sections (12), (14) and (16). A wire shoe (18) extends forwardly and to the side from the lower end of the lower guard section (16). A band knife guard (10) has a mounting (20) extending from the upper guard section (12) and is arranged to be attached

to the body of a band knife machine (46), so that the upper, middle and lower guard sections surround the two main faces of a band knife blade (22). A wire lifting handle (24) extends upwardly from the base of the lower guard section (16) to facilitate lifting of the band knife guard (10).

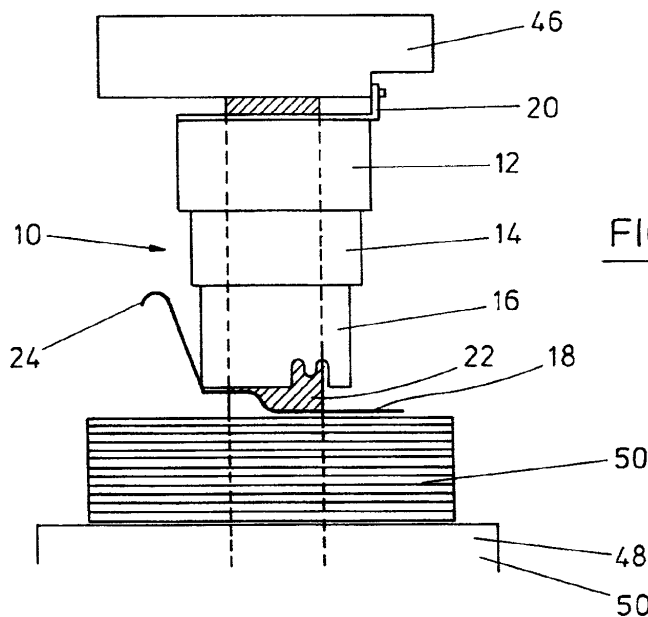

FIG. 5a



European Patent
Office

EUROPEAN SEARCH REPORT

Application Number
EP 99 30 2137

DOCUMENTS CONSIDERED TO BE RELEVANT			
Category	Citation of document with indication, where appropriate, of relevant passages	Relevant to claim	CLASSIFICATION OF THE APPLICATION (Int.Cl.6)
X	US 2 627 657 A (ETCHEN) 10 February 1953 (1953-02-10)	1, 3, 9-11	B26D7/22 F16P1/02
Y	* column 1, line 46 - column 2, line 45; figures *	2, 4, 6	
Y	DE 28 21 591 A (GERT LOUISODER GMBH & CO BEKLE) 22 November 1979 (1979-11-22) * page 7, line 33 - page 8, line 5 * * page 8, paragraph 2 - page 9, paragraph 3 *	2, 4, 6	
A	CH 281 413 A (FIRMA K. MISCHKE) * page 2, line 15 - line 19; figures *	2, 4	
A	DE 28 56 730 A (GERT LOUISODER GMBH & CO BEKLE) 10 July 1980 (1980-07-10)		
X	EP 0 109 632 A (EISELE MASCHF CHR) 30 May 1984 (1984-05-30) * abstract *	1-4, 7, 11	
X	WO 97 47443 A (PORTER BRIAN KEVIN) 18 December 1997 (1997-12-18) * page 11, line 1 - line 15; figures *	1-5, 9, 11	TECHNICAL FIELDS SEARCHED (Int.Cl.6)
X	EP 0 519 610 A (KM CLOTH CUTTING MACHINE) 23 December 1992 (1992-12-23) * column 3, line 22 - line 31; figures * * column 4, line 26 - column 5, line 2 *	1-3, 6, 8, 10, 11	B26D A41H B27G F16P
X	EP 0 193 672 A (EASTMAN MACHINE CO) 10 September 1986 (1986-09-10) * abstract * * page 9, line 6 - line 18 * * page 18, line 18 - line 22 * * page 19, line 11 - line 29; figures * * page 21, line 11 - line 13 *	1-3, 6, 9-11	
		-/--	
The present search report has been drawn up for all claims			
Place of search		Date of completion of the search	Examiner
THE HAGUE		26 May 2000	Vaglianti, G
CATEGORY OF CITED DOCUMENTS			
X : particularly relevant if taken alone		T : theory or principle underlying the invention	
Y : particularly relevant if combined with another document of the same category		E : earlier patent document, but published on, or after the filing date	
A : technological background		D : document cited in the application	
O : non-written disclosure		L : document cited for other reasons	
P : intermediate document		& : member of the same patent family, corresponding document	

EPO FORM 1503 03/82 (P04C01)



European Patent
Office

EUROPEAN SEARCH REPORT

Application Number
EP 99 30 2137

DOCUMENTS CONSIDERED TO BE RELEVANT			
Category	Citation of document with indication, where appropriate, of relevant passages	Relevant to claim	CLASSIFICATION OF THE APPLICATION (Int.Cl.6)
X	PATENT ABSTRACTS OF JAPAN vol. 1996, no. 12, 26 December 1996 (1996-12-26) -& JP 08 197494 A (K M SAIDANKI:KK), 6 August 1996 (1996-08-06)	1-4, 8, 9, 11	
Y	* abstract *	7	
Y	EP 0 394 132 A (INST NAT RECH SECURITE) 24 October 1990 (1990-10-24) * abstract; figures *	7	
A	GB 720 558 A (THOMAS BEECROFT AND CO.) * page 1, line 63 - page 2, line 56 *	5, 8	
A	FR 565 433 A (INDERBITZIN) 26 January 1924 (1924-01-26)		
			TECHNICAL FIELDS SEARCHED (Int.Cl.6)
The present search report has been drawn up for all claims			
Place of search		Date of completion of the search	Examiner
THE HAGUE		26 May 2000	Vaglianti, G
CATEGORY OF CITED DOCUMENTS			
X : particularly relevant if taken alone Y : particularly relevant if combined with another document of the same category A : technological background O : non-written disclosure P : intermediate document		T : theory or principle underlying the invention E : earlier patent document, but published on, or after the filing date D : document cited in the application L : document cited for other reasons & : member of the same patent family, corresponding document	

EPO FORM 1503 03/82 (PC4C01)

ANNEX TO THE EUROPEAN SEARCH REPORT
ON EUROPEAN PATENT APPLICATION NO.

EP 99 30 2137

This annex lists the patent family members relating to the patent documents cited in the above-mentioned European search report. The members are as contained in the European Patent Office EDP file on
The European Patent Office is in no way liable for these particulars which are merely given for the purpose of information.

26-05-2000

Patent document cited in search report	Publication date	Patent family member(s)	Publication date
US 2627657 A	10-02-1953	NONE	
DE 2821591 A	22-11-1979	NONE	
CH 281413 A		NONE	
DE 2856730 A	10-07-1980	NONE	
EP 0109632 A	30-05-1984	DE 3242572 A JP 59146713 A	24-05-1984 22-08-1984
WO 9747443 A	18-12-1997	AU 3349497 A	07-01-1998
EP 0519610 A	23-12-1992	JP 4354694 A AU 654012 B AU 1731192 A US 5274923 A	09-12-1992 20-10-1994 03-12-1992 04-01-1994
EP 0193672 A	10-09-1986	US 4712303 A JP 61188097 A	15-12-1987 21-08-1986
JP 08197494 A	06-08-1996	NONE	
EP 0394132 A	24-10-1990	FR 2647384 A AT 86538 T DE 69001036 D DE 69001036 T DK 394132 T GR 91300034 T	30-11-1990 15-03-1993 15-04-1993 17-06-1993 13-04-1993 15-11-1991
GB 720558 A		NONE	
FR 565433 A	26-01-1924	NONE	

EPO FORM P0459

For more details about this annex : see Official Journal of the European Patent Office, No. 12/82