

(19) World Intellectual Property Organization  
International Bureau



(43) International Publication Date  
11 January 2001 (11.01.2001)

PCT

(10) International Publication Number  
WO 01/02810 A1

- (51) International Patent Classification<sup>7</sup>: G01F 1/74, 1/712, 1/708 06457 (US). WINSTON, Charles, R.; 109 Cambridge Drive, Glastonbury, CT 06033 (US).
- (21) International Application Number: PCT/US00/17640 (81) Designated States (national): AE, AL, AM, AT, AU, AZ, BA, BB, BG, BR, BY, CA, CH, CN, CR, CU, CZ, DE, DK, DM, EE, ES, FI, GB, GD, GE, GH, GM, HR, HU, ID, IL, IN, IS, JP, KE, KG, KP, KR, KZ, LC, LK, LR, LS, LT, LU, LV, MA, MD, MG, MK, MN, MW, MX, NO, NZ, PL, PT, RO, RU, SD, SE, SG, SI, SK, SL, TJ, TM, TR, TT, TZ, UA, UG, UZ, VN, YU, ZA, ZW.
- (22) International Filing Date: 27 June 2000 (27.06.2000)
- (25) Filing Language: English
- (26) Publication Language: English
- (30) Priority Data: 09/346,607 2 July 1999 (02.07.1999) US (84) Designated States (regional): ARIPO patent (GH, GM, KE, LS, MW, MZ, SD, SL, SZ, TZ, UG, ZW), Eurasian patent (AM, AZ, BY, KG, KZ, MD, RU, TJ, TM), European patent (AT, BE, CH, CY, DE, DK, ES, FI, FR, GB, GR, IE, IT, LU, MC, NL, PT, SE), OAPI patent (BF, BJ, CF, CG, CI, CM, GA, GN, GW, ML, MR, NE, SN, TD, TG).
- (71) Applicant: CIDRA CORPORATION [US/US]; 50 Barnes Park North, Wallingford, CT 06492 (US). Published: — With international search report.
- (72) Inventors: GYSLING, Daniel, L.; 763 Chestnut Hill Road, Glastonbury, CT 06033 (US). MCGUINN, Rebecca, S.; 14-20 Forest Glenn Circle, Middletown, CT

[Continued on next page]

(54) Title: FLOW RATE MEASUREMENT USING UNSTEADY PRESSURES

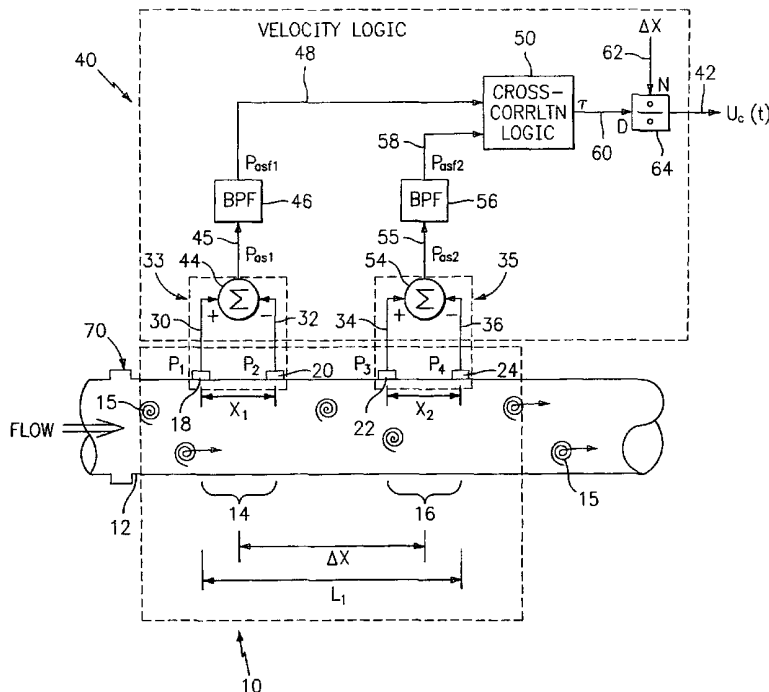

(57) Abstract: Flow rate measurement system includes two measurement regions (14, 16) located an average axial distance  $\Delta X$  apart along the pipe (12), the first measurement region (14) having two unsteady pressure sensors (18, 20), located a distance  $X_1$  apart, and the second measurement region (16), having two other unsteady pressure sensors (22, 24), located a distance  $X_2$  apart, each capable of measuring the unsteady pressure in the pipe (12). Signals from each pair of pressure sensors (18, 20) and (22, 24) are differenced by summers (44, 54), respectively, to form spatial wavelength filters (33, 35), respectively. Each spatial filter (33, 35) filters out acoustic pressure disturbances  $P_{acoustic}$  and other long wavelength pressure disturbances in the pipe (12) and passes short-wavelength low-frequency vortical pressure disturbances  $P_{vortical}$  associated with the vortical flow field (15). The spatial filters (33, 35)

provide signals  $P_{as1}$ ,  $P_{as2}$  to band pass filterS (46, 56) that filter out high frequency signals. The  $P_{vortical}$ -dominated filtered signals  $P_{asf1}$ ,  $P_{asf2}$  from the two regions (14, 16) are cross-correlated by Cross-Correlation Logic (50) to determine a time delay  $\tau$  between the two sensing locations (14, 16) which is divided into the distance  $\Delta X$  to obtain a convection velocity  $U_c(t)$  that is related to an average flow rate of the fluid (i.e., one or more liquids and/or gases) flowing in the pipe (12). The invention may also be configured to detect the velocity of any desired inhomogeneous pressure field in the flow.



WO 01/02810 A1



— Before the expiration of the time limit for amending the claims and to be republished in the event of receipt of amendments.

For two-letter codes and other abbreviations, refer to the "Guidance Notes on Codes and Abbreviations" appearing at the beginning of each regular issue of the PCT Gazette.

## Flow Rate Measurement Using Unsteady Pressures

### Cross References to Related Applications

This application is related to commonly owned co-pending US Patent  
5 Application Serial Nos. 09/346,604; 09/346,605; 09/346,606 and 09/345,827; filed  
July 2, 1999.

### Technical Field

This invention relates to the measurement of flow rate of a fluid and more  
particularly to measuring flow rate using unsteady pressure measurements.

### 10 Background Art

In many industries it is desirable to measure the flow rate of a multiphase  
fluid. In the oil and gas industry, or comparable industries, for example, it is desirable  
to measure the flow rate of multiphase fluids, especially fluids having three phases,  
such as oil, water and gas. It is known also to measure the flow rate of certain fluids  
15 (one or more liquids and/or gases) in a pipe using cross-correlation flow meters. Such  
meters measure an element of the flow that moves or convects with (or is related to)  
the fluid flow (or a group of fluid particles). The meter measures this element at two  
locations separated by a known distance along the flow path and then calculates the  
time for such element to move between the two locations. The time delay is  
20 determined by a cross-correlation of the two measured signals. A velocity is then  
determined by the distance between the measurements divided by the time delay. The  
flow velocity is then related to the flow rate by calibration.

One such cross-correlation meter that measures flow rate in a multiphase flow  
is described in US Patent No. 5,591,922, entitled "Method and Apparatus for  
25 Measuring Multiphase Flow", to Segeral et al, issued Jan. 7, 1997. In that case, a pair  
of venturis are located a predetermined distance apart which induce a change in flow  
speed through the venturi and a resulting pressure difference (or delta-P) across each  
venturi, which are measured. The delta-P pressure signals measured at each venturi  
are cross-correlated to determine the time delay which is indicative of the total  
30 volume flow rate. However, such a technique requires a change in the flow properties  
(e.g., flow velocity or density) at the two measurement points to make the

measurement. Also, the delta-P is generated with an area contraction or constriction, and is not a naturally occurring observable characteristic of the fluid.

### Summary of the Invention

5           Objects of the present invention include provision of a system for measuring the flow rate (or velocity) of fluid flow in pipes.

          According to the present invention, an apparatus for measuring a velocity of a fluid moving in a pipe, comprises a first filter which measures a vortical pressure field at a first axial location along the pipe which provides a first pressure signal indicative of the vortical pressure field; and a second filter which measures the vortical pressure field at a second axial location along the pipe which provides a second pressure signal indicative of the vortical pressure field. The invention further comprises a signal processor, responsive to the first and the second pressure signals, which provides a velocity signal indicative of a velocity of the vortical pressure field moving in the pipe.

          According further to the present invention, the first and the second filters passes wavelengths associated with the vortical pressure field and not associated with an acoustic pressure field. According further to the present invention, the first filter comprises a first spatial filter; and the second filter comprises a second spatial filter.

20   According still further to the present invention, the vortical pressure field comprises a homogeneous pressure field. Still further according to the present invention, the first and the second filters pass wavelengths associated with the vortical pressure field and not associated with an acoustic pressure field. According further to the present invention, the spatial filter filters out wavelengths above a predetermined wavelength.

25   Still further according to the present invention, at least one of the pressure sensors comprises a strain gage disposed on a surface of the pipe. Further according to the present invention, the strain gage comprises a fiber optic strain gage.

          Still further according to the present invention, the signal processor comprises logic which calculates a cross-correlation between the first and the second inhomogeneous pressure signals and provides a time delay signal indicative of the time it takes for the vortical pressure field to move from the first location to the

second location. Further according to the present invention, the velocity signal is indicative of the velocity of the fluid moving in the pipe.

The present invention provides a significant improvement over the prior art by providing a measurement of the average flow rate of fluid flow in a pipe or other  
5 conduit (where a fluid is defined as one or more liquids and/or gases) without requiring a flow restriction in the pipe or any other change in the flow velocity of the fluid.

The present invention determines a convection velocity by measuring unsteady (or dynamic or ac) pressures and extracting the pressure signal indicative of  
10 a vortical pressure (or flow) field (or perturbation) which convects at or near the average velocity of the fluid. The vortical pressure field is then used to determine the convection velocity by cross-correlation techniques, such convection velocity being proportional (or approximately equal to) the flow rate of the fluid. If needed, the flow rate of the fluid may then be determined by calibrating the convection velocity to the  
15 flow rate.

The invention may also be used to measure the velocity of any inhomogeneous flow field, such as gas bubbles, gas slugs, particles, or chunks of material, and its associated pressure field that propagates in a flow provided the spatial filters have a separation within the acceptable coherence length of the flow field to be measured  
20 and the sensor spacing within each spatial filter is longer than a characteristic axial length of the flow field. Also, the invention may be used to detect different flow rates within the same mixture (e.g., the flow rate of a vortical pressure field as well as other inhomogeneous pressure fields).

Also, the invention may be used with any combination of liquids and/or gases  
25 and may include particles. The invention will also work in any other environment or applications or any other fluids (one or more liquids and/or gases) or mixtures. The invention will work with any pipe or tube or with any conduit that carries fluid. Also, the invention has no inherent flow range limitations, and, as such, can measure very low flow rates and has no maximum flow rate limit. The invention will also work if  
30 the fluid is flowing in either direction in the pipe. Further, the invention may be used directly on a pipe or on a tube inserted into a flowing fluid.

The foregoing and other objects, features and advantages of the present invention will become more apparent in light of the following detailed description of exemplary embodiments thereof.

## 5 **Brief Description of the Drawings**

Fig. 1 is a schematic block diagram of a velocity measurement system, in accordance with the present invention.

Fig. 2 is a side view of a pipe having two sensors that measure a parameter that convects with the flow in the pipe, in accordance with the present invention.

10 Fig. 3 is a graph of two curves, one from each of the two sensors of Fig. 2, in accordance with the present invention.

Fig. 4 is a graph of a cross-correlation between the two curves of Fig. 3, in accordance with the present invention.

15 Fig. 5 is a graph of power spectral density plotted against frequency for an unsteady acoustic pressure signal  $P_{\text{acoustic}}$  and unsteady vortical pressure signal  $P_{\text{vortical}}$ , in accordance with the present invention.

Fig. 6 is a graph of wavelength versus frequency for unsteady acoustic pressures  $P_{\text{acoustic}}$  and unsteady vortical pressures  $P_{\text{vortical}}$ , in accordance with the present invention.

20 Fig. 7 is a graph of power spectrum of two unsteady pressures and the difference between the two pressures, in accordance with the present invention.

Fig. 8 is a graph of a cross-correlation between two of the curves of Fig. 7, in accordance with the present invention.

25 Fig. 9 is a graph of measured velocity against reference velocity, in accordance with the present invention.

Fig. 10 is a side view of a pipe having three pairs of unsteady pressure sensors spaced axially along the pipe, in accordance with the present invention.

Fig. 11 is a graph of a cross correlation coefficient versus time delay for the three pairs of sensors, in accordance with the present invention.

30 Fig. 12 is a graph of measured flow rate against reference flow rate for various different mixtures, in accordance with the present invention.

Fig. 13 is an end view of a pipe showing pressure inside and outside the pipe, in accordance with the present invention.

Fig. 14 is a side view of a pipe having optical fiber wrapped around the pipe at each unsteady pressure measurement location and a pair of Bragg gratings around  
5 each optical wrap, in accordance with the present invention.

Fig. 15 is a side view of a pipe having optical fiber wrapped around the pipe at each unsteady pressure measurement location with a single Bragg grating between each pair of optical wraps, in accordance with the present invention.

Fig. 16 is a side view of a pipe having optical fiber wrapped around the pipe at  
10 each unsteady pressure measurement location without Bragg gratings around each of the wraps, in accordance with the present invention.

Fig. 17 is an alternative geometry of an optical wrap of Figs. 14,15&16, of a radiator tube geometry, in accordance with the present invention.

Fig. 18 is an alternative geometry of an optical wrap of Figs. 14,15&16, of a  
15 race track geometry, in accordance with the present invention.

Fig. 19 is a side view of a pipe having a pair of gratings at each axial sensing location, in accordance with the present invention.

Fig. 20 is a side view of a pipe having a single grating at each axial sensing location, in accordance with the present invention.

Fig. 21 is a side view of a pipe having two pairs of pressure sensors where the  
20 sensors in each pair are located across the pipe from each other, in accordance with the present invention.

Fig. 22 is an end view of a pipe showing a pair of pressure sensors located at various circumferential spacings from each other, in accordance with the present  
25 invention.

Fig. 23 is a side view of a pipe having two pairs of pressure sensors where the sensors in each pair are located transversely across the pipe and spaced axially along the pipe from each other, in accordance with the present invention.

Fig. 24 is a side view of a pipe having a set of three pressure sensors that form  
30 a spatial filter, in accordance with the present invention.

Fig. 25 is a side view of a pipe having an inner tube with axially distributed optical fiber wraps for unsteady pressure sensors, in accordance with the present invention.

5 Fig. 26 is a side view of a pipe having an inner tube with axially distributed unsteady pressure sensors located along the tube, in accordance with the present invention.

Fig. 27 is a side view of a pipe having an inner tube with four axially distributed optical fiber wrapped hydrophones located within the tube, in accordance with the present invention.

10 Fig. 28 is an end view of a pipe showing a pair of pressure sensors spaced apart from each other within the pipe, in accordance with the present invention.

Fig. 29 is a side view of a pipe having a pair of unsteady pressure sensors spaced axially within the pipe, in accordance with the present invention.

15 Fig. 30 is a side view of a pipe having a pair of unsteady pressure sensors spaced transversely within the pipe, in accordance with the present invention.

Fig. 31 is a side view of a pipe having a pair of unsteady pressure sensors axially and radially spaced within the pipe, in accordance with the present invention.

Fig. 32 is a side view of a pipe having a set of three pressure sensors that make up two spatial filters, in accordance with the present invention.

20 Fig. 33 is a schematic drawing of a flow meter in a well, in accordance with the present invention.

Fig. 34 is a plan view of alternate geometries for electronic strain gages in accordance with the present invention.

25 Fig. 35 is a side view of a pipe having a spatial filter disposed thereon comprised of electronic strain gages in accordance with the present invention.

### **Best Mode for Carrying Out the Invention**

Referring to Fig. 1, a velocity and flow measurement system includes a sensing section 10 along a pipe 12 and a velocity logic section 40. The pipe (or conduit) 12  
30 has two measurement regions 14,16 located a distance  $\Delta X$  apart along the pipe 12. At the first measurement region 14 are two unsteady (or dynamic or ac) pressure sensors



18,20, located a distance  $X_1$  apart, capable of measuring the unsteady pressure in the pipe 12, and at the second measurement region 16, are two other unsteady pressure sensors 22,24, located a distance  $X_2$  apart, capable of measuring the unsteady pressure in the pipe 12. Each pair of pressure sensors 18,20 and 22,24 act as spatial filters to  
5 remove certain acoustic signals from the unsteady pressure signals, and the distances  $X_1, X_2$  are determined by the desired filtering characteristic for each spatial filter, as discussed hereinafter.

The flow measurement system 10 of the present invention measures velocities associated with unsteady flow fields and/or pressure disturbances represented by 15 associated therewith relating to turbulent eddies (or vortical flow fields), inhomogeneities in the flow (such as bubbles, slugs, and the like), or any other properties of the flow, fluid, or pressure, having time varying or stochastic properties that are manifested at least in part in the form of unsteady pressures. The vortical flow fields 15 are, in general, comprised of pressure disturbances having a wide  
15 variation in length scales and which have a variety of coherence length scales such as that described in the reference "Sound and Sources of Sound", A. P. Dowling et al, Halsted Press, 1983. Certain of these vortical flow fields convect at or near/or related to the mean velocity of at least one of the fluids within a mixture flowing in a pipe. More specifically, the vortices convect in a predictable manner with reference to the  
20 fluids. The vortical pressure disturbances 15 that contain information regarding convection velocity have temporal and spatial length scales as well as coherence length scales that differ from other disturbances in the flow. The present invention utilizes these properties to preferentially select disturbances of a desired axial length scale and coherence length scale as will be more fully described hereinafter. For  
25 illustrative purposes, the terms vortical flow field and vortical pressure field will be used to describe the above-described group of unsteady pressure fields having temporal and spatial length and coherence scales described herein.

The pressures  $P_1, P_2, P_3, P_4$  may be measured through holes in the pipe 12 ported to external pressure sensors or by other techniques discussed hereinafter. The  
30 pressure sensors 18,20,22,24 provide time-based pressure signals  $P_1(t), P_2(t), P_3(t), P_4(t)$  on lines 30,32,34,36, respectively, to Velocity Logic 40 which provides a

convection velocity signal  $U_c(t)$  on a line 42 which is related to an average flow rate  $U_f(t)$  of the fluid flowing in the pipe 12 (where fluid may comprise one or more liquids and/or gases; where the gas(es) may be dissolved in the liquid or in free gas form, such as bubbles, slugs, sand, particulates, slurry, etc.), and wherein the fluid  
5 may include non-liquid elements therein as will be discussed more hereinafter.

Also, some or all of the functions within the Velocity Logic 40 may be implemented in software (using a microprocessor or computer) and/or firmware, or may be implemented using analog and/or digital hardware, having sufficient memory, interfaces, and capacity to perform the functions described herein.

10 In particular, in the Velocity Logic 40, the pressure signal  $P_1(t)$  on the line 30 is provided to a positive input of a summer 44 and the pressure signal  $P_2(t)$  on the line 32 is provided to a negative input of the summer 44. The output of the summer 44 is provided on a line 45 indicative of the difference between the two pressure signals  $P_1, P_2$  (e.g.,  $P_1 - P_2 = P_{as1}$ ).

15 The pressure sensors 18,20 together with the summer 44 create a spatial filter 33. The line 45 is fed to bandpass filter 46, which passes a predetermined passband of frequencies and attenuates frequencies outside the passband. In accordance with the present invention, the passband of the filter 46 is set to filter out (or attenuate) the dc portion and the high frequency portion of the input signals and to pass the frequencies  
20 therebetween. For example, in a particular embodiment passband filter 6 is set to pass frequencies from about 1 Hz to about 100 Hz, for a 3 inch ID pipe flowing water at 10 ft/sec. Other passbands may be used in other embodiments, if desired. Passband filter 46 provides a filtered signal  $P_{asf1}$  on a line 48 to Cross-Correlation Logic 50, described hereinafter.

25 The pressure signal  $P_3(t)$  on the line 34 is provided to a positive input of a summer 54 and the pressure signal  $P_4(t)$  on the line 36 is provided to a negative input of the summer 54. The pressure sensors 22,24 together with the summer 54 create a spatial filter 35. The output of the summer 54 is provided on a line 55 indicative of the difference between the two pressure signals  $P_3, P_4$  (e.g.,  $P_3 - P_4 = P_{as2}$ ). The line 55 is fed  
30 to a bandpass filter 56, similar to the bandpass filter 46 discussed hereinbefore, which passes frequencies within the passband and attenuates frequencies outside the

passband. The filter 56 provides a filtered signal  $P_{asf2}$  on a line 58 to the Cross-Correlation Logic 50. The signs on the summers 44,54 may be swapped if desired, provided the signs of both summers 44,54 are swapped together. In addition, the pressure signals  $P_1, P_2, P_3, P_4$  may be scaled prior to presentation to the summers 44,54.

5           The Cross-Correlation Logic 50 calculates a known time domain cross-correlation between the signals  $P_{asf1}$  and  $P_{asf2}$  on the lines 48,58, respectively, and provides an output signal on a line 60 indicative of the time delay  $\tau$  it takes for an vortical flow field 15 (or vortex, stochastic, or vortical structure, field, disturbance or perturbation within the flow) to propagate from one sensing region 14 to the other  
10 sensing region 16. Such vortical flow disturbances, as is known, are coherent dynamic conditions that can occur in the flow which substantially decay (by a predetermined amount) over a predetermined distance (or coherence length) and convect (or flow) at or near the average velocity of the fluid flow. As described above, the vortical flow field 15 also has a stochastic or vortical pressure disturbance  
15 associated with it. In general, the vortical flow disturbances 15 are distributed throughout the flow, particularly in high shear regions, such as boundary layers (e.g., along the inner wall of the pipe 12) and are shown herein as discrete vortical flow fields 15. Because the vortical flow fields 15 (and the associated pressure disturbance) convect at or near the mean flow velocity, the propagation time delay  $\tau$  is  
20 related to the velocity of the flow by the distance  $\Delta X$  between the measurement regions 14,16, as discussed hereinafter.

          Although pressure disturbances associated with vortical flow fields 15 occur naturally in most flow conditions, an optional circumferential groove 70 may be used in the inner diameter of the pipe 12 to help generate unsteady flow fields in the form  
25 of vertices into the flow. However, the groove 70 is not required for the present invention to operate, due to vortex generation which naturally occurs along the pipe inner wall, as discussed hereinbefore. Instead of a single circumferential groove 70 a plurality of axially spaced circumferential grooves may be used. The dimensions and geometry of the groove(s) 70 may be set based on the expected flow conditions and  
30 other factors. The axial cross-sectional shape of the groove 70 may be rectangular, square, triangular, circular, oval, star, or other shapes. Other techniques may be used

as vortex generators if desired including those that may protrude within the inner diameter of pipe 12.

A spacing signal  $\Delta X$  on a line 62 indicative of the distance  $\Delta X$  between the sensing regions 14,16 is divided by the time delay signal  $\tau$  on the line 60 by a divider 5 64 which provides an output signal on the line 42 indicative of the convection velocity  $U_c(t)$  of the fluid flowing in the pipe 12, which is related to (or proportional to or approximately equal to) the average (or mean) flow velocity  $U_f(t)$  of the fluid, as defined below:

$$U_c(t) = \Delta X/\tau \propto U_f(t) \quad \text{Eq. 1}$$

10 The convection velocity  $U_c(t)$  may then be calibrated to more precisely determine the mean velocity  $U_f(t)$  if desired. The result of such calibration may require multiplying the value of the convection velocity  $U_c(t)$  by a calibration constant (gain) and/or adding a calibration offset to obtain the mean flow velocity  $U_f(t)$  with the desired accuracy. Other calibration may be used if desired. For some applications, 15 such calibration may not be required to meet the desired accuracy. The velocities  $U_f(t), U_c(t)$  may be converted to volumetric flow rate by multiplying the velocity by the cross-sectional area of the pipe.

Referring to Figs. 2,3,4, as is known, cross-correlation may be used to determine the time delay  $\tau$  between two signals  $y_1(t), y_2(t)$  separated by a known 20 distance  $\Delta X$ , that are indicative of quantities 80 that convect with the flow (e.g., density perturbations, concentration perturbations, temperature perturbations, vortical pressure disturbances, and other quantities). In Fig. 3, the signal  $y_2(t)$  lags behind the signal  $y_1(t)$  by 0.15 seconds. If a time domain cross-correlation is taken between the two signals  $y_1(t), y_2(t)$ , the result is shown in Fig. 4 as a curve 84. The highest peak 86 25 of the curve 84 shows the best fit for the time lag  $\tau$  between the two signals  $y_1(t), y_2(t)$  is at 0.15 seconds which matches the reference time delay shown in Fig. 3.

Referring to Fig. 1, as discussed hereinbefore, since pressure disturbances associated within the vortical flow field 15 convect (or flow) at or near the average velocity of the fluid flowing in the pipe 12, the vortical pressure disturbances 30 observed at the downstream location 16 are substantially a time lagged version of the

vortical pressure disturbances observed at the upstream location 14. However, the total vortical pressure perturbations or disturbances in a pipe may be expressed as being comprised of vortical pressure disturbances ( $P_{\text{vortical}}$ ), acoustic pressure disturbances ( $P_{\text{acoustic}}$ ) and other types of pressure disturbances ( $P_{\text{other}}$ ) as shown below  
 5 expressed in terms of axial position along the pipe at any point in time:

$$P(x,t) = P_{\text{vortical}}(x,t) + P_{\text{acoustic}}(x,t) + P_{\text{other}}(x,t) \quad \text{Eq. 2}$$

As a result, the unsteady pressure disturbances  $P_{\text{vortical}}$  can be masked by the acoustic pressure disturbances  $P_{\text{acoustic}}$  and the other types of pressure disturbances  $P_{\text{other}}$ . In particular, the presence of the acoustic pressure disturbances that propagate  
 10 both upstream and downstream at the speed of sound in the fluid (sonic velocity), can prohibit the direct measurement of velocity from cross-correlation of direct vortical pressure measurements.

The present invention uses temporal and spatial filtering to precondition the pressure signals to effectively filter out the acoustic pressure disturbances  $P_{\text{acoustic}}$  and  
 15 other long wavelength (compared to the sensor spacing) pressure disturbances in the pipe 12 at the two sensing regions 14,16 and retain a substantial portion of the vortical pressure disturbances  $P_{\text{vortical}}$  associated with the vortical flow field 15 and any other short wavelength (compared to the sensor spacing) low frequency pressure disturbances  $P_{\text{other}}$ . In accordance with the present invention, if the low frequency  
 20 pressure disturbances  $P_{\text{other}}$  are small, they will not substantially impair the measurement accuracy of  $P_{\text{vortical}}$ .

The  $P_{\text{vortical}}$  dominated signals from the two regions 14,16 are then cross-correlated to determine the time delay  $\tau$  between the two sensing locations 14,16. More specifically, at the sensing region 14, the difference between the two pressure  
 25 sensors 18,20 creates a spatial filter 33 that effectively filters out (or attenuates) acoustic disturbances for which the wavelength  $\lambda$  of the acoustic waves propagating along the fluid is long (e.g., ten-to-one) compared to the spacing  $X_1$  between the sensors. Other wavelength to sensor spacing ratios may be used to characterize the filtering, provided the wavelength to sensor spacing ratio is sufficient to satisfy the  
 30 two-to-one spatial aliasing Nyquist criteria.

Thus, if the pressure sensors  $P_1, P_2$  have an axial spacing  $X_1$ , and assuming that the spatial filter 33 will attenuate acoustic wavelengths longer than about 10 times the sensor spacing  $X_1$ , the smallest acoustic wavelength  $\lambda_{\min}$  that is attenuated would be:

$$\lambda_{\min} = 10 (X_1) \quad \text{Eq. 3}$$

5 One dimensional acoustic disturbances are also governed by the following known inverse wavelength-frequency relation:

$$\lambda = a / f \text{ or } f = a / \lambda \quad \text{Eq. 4}$$

where  $a$  is the speed of sound of the fluid,  $f$  is the frequency of the acoustic disturbance, and  $\lambda$  is the wavelength of the acoustic disturbance.

10 Using Eq. 4, such a spatial filter would filter out frequencies below about:

$$f_{\max} = a / \lambda_{\min} \quad \text{Eq. 5}$$

For example, using water ( $a = 5,000$  ft/sec) with a sensor spacing  $X_1 = 3$  inches, the above described spatial acoustic filtering would filter out acoustic frequencies up to a maximum frequency of about 2000 Hz (or  $5,000 * 12 / 30$ ). Thus, 15 the acoustic frequency content of the output signal  $P_{as1}$  of the spatial filter 33 (i.e., differenced vortical pressure signal) will be effectively removed for frequencies below about 2000 Hz and wavelengths above 30 inches (using Eq. 3).

The above discussion on the spatial filter 33 also applies to the second spatial filter 35 comprising the other pair of pressure signals  $P_3, P_4$ , axially spaced a distance 20  $X_2$  apart, which provides the differenced vortical pressure signal  $P_{as2}$ .

Referring to Fig. 5, relevant features of the power spectral density (PSD) of typical vortical pressure disturbances  $P_{\text{vortical}}$  is shown by a curve 90 that has a flat region (or bandwidth) up to a frequency  $F_v$  and then decreases with increasing frequency  $f$ . The value of  $F_v$  is approximately equal to  $U/r$ , where  $U$  is the flow rate 25 and  $r$  is the radius of the pipe. For example, for a flow rate  $U$  of about 10 ft/sec and a pipe radius  $r$  of about 0.125 ft (or about 1.5 inches), the bandwidth  $F_v$  of the vortical pressure disturbances  $P_{\text{vortical}}$  would be about 80 Hz ( $10/0.125$ ). The PSD of the acoustic pressure disturbances  $P_{\text{acoustic}}$  has a profile that is determined by the environment and other factors and is indicated in the figure by an arbitrary curve 91, 30 and typically has both low and high frequency components.

Referring to Fig. 6, in general, the acoustic pressure disturbances  $P_{\text{acoustic}}$  have an inverse wavelength-frequency relationship as shown in Eq. 4, which has long wavelengths at low frequencies and short wavelengths at high frequencies as indicated by the regions 96,98, respectively. Conversely, the vortical pressure disturbances  $P_{\text{vortical}}$  have both long and short wavelengths as indicated by the regions 96,97, respectively; however, they exist primarily at low frequencies (as discussed hereinbefore with reference to Fig. 5). Thus, both  $P_{\text{acoustic}}$  and  $P_{\text{vortical}}$  exist in the long wavelength, low frequency region 96, and only  $P_{\text{vortical}}$  exists in the short wavelength low frequency region 97.

The acoustic spatial filters 33,35 (Fig. 1) discussed hereinbefore block or attenuate wavelengths longer than  $\lambda_{\text{as}}$  and frequencies below  $f_{\text{as}}$ , as indicated by the region 96. Also, the bandpass filters (BPF) 46,56 (Fig. 1) block or attenuate high frequencies above  $f_{\text{pb}}$  having short and long wavelengths as indicated by a region 102 and pass frequencies below  $f_{\text{as}}$  where the  $P_{\text{vortical}}$  signals exist. Thus, after the spatial filters 33,35 and the BPF's 46,56, the resultant filtered signals  $P_{\text{asf1}}$ ,  $P_{\text{asf2}}$  on the lines 48,58 (Fig. 1) will be dominated by the short wavelength unsteady pressure disturbances  $P_{\text{vortical}}$  as indicated by the region 97 (Fig. 6) at frequencies below  $f_{\text{pb}}$  and as indicated by a portion 94 of the curve 90 in the BPF passband 95 (Fig. 5).

Accordingly, referring to Fig. 5, the spatial filters 33,35 (Fig. 1) block the long wavelengths, which, for the acoustic pressure disturbances  $P_{\text{acoustic}}$ , occur at low frequencies as indicated to the left of a dashed line 92 at frequencies below the frequency  $f_{\text{as}}$ . A dashed line 93 indicates the attenuation of the acoustic pressure  $P_{\text{acoustic}}$  signal 91 below the frequency  $f_{\text{as}}$  at the output of the spatial filters. The vortical pressure disturbances  $P_{\text{vortical}}$  are substantially not attenuated (or only slightly attenuated) because  $P_{\text{vortical}}$  has short wavelengths at low frequencies that are substantially passed by the spatial filter. The BPF's 46,56 (Fig. 1) block or attenuate frequencies outside the passband indicated by a range of frequencies 95, and passes the unsteady pressure disturbances associated with stochastic flow fields 15 (Fig. 1) within the passband 95.

Alternatively, instead of the filters 46,56 being bandpass filters, provided the dc content is acceptably small, the filters 46,56 may comprise low pass filters, having

a bandwidth similar to the upper band of the high pass filters discussed hereinbefore. If a low pass filter is used as the filters 46,56, the passband is shown as a range of frequencies 89. It should be understood that the filters 46,56 are not required for the present invention if the PSD of the acoustic pressure disturbances  $P_{\text{acoustic}}$  has

5 substantially no or low PSD energy content in frequencies above the stopband of the spatial filter that does not adversely affect the measurement accuracy.

Referring to Figs. 7 and 1, for the four ac pressure sensors 18,20,22,24 evenly axially spaced at 1 inch apart ( $X_1, X_2$ ) along the pipe 12, and providing ac pressure signals  $P_1, P_2, P_3, P_4$ , respectively, the frequency power spectrum for  $P_1$  and  $P_2$  are

10 shown by curves 100,102, respectively, for water flowing in an horizontal flow loop at a velocity of 11.2 ft/sec in a 2 inch diameter schedule 80 pipe using conventional piezoelectric ac pressure transducers. The power spectra of the curves 100,102 are nearly identical. The power spectrum of the difference  $P_{\text{as1}}$  between the two signals  $P_1, P_2$ , shown by a curve 104 is reduced in certain frequency bands (e.g., 100-150 Hz)

15 and increased in other frequency bands (e.g., 200-250 Hz) as compared to the individual signals 100,102.

Referring to Figs. 8 and 1, the cross correlation between the signals  $P_{\text{as1}}$  (or  $P_1 - P_2$ ) and  $P_{\text{as2}}$  ( $P_3 - P_4$ ) is shown as a curve 110. The highest peak 112 indicates the best fit for the time lag between the two signals  $P_{\text{as1}}, P_{\text{as2}}$  as 0.015 seconds. Because the

20 four sensors  $P_1$  to  $P_4$  were evenly axially spaced 1 inch apart, the effective distance  $\Delta X$  between the sensor pairs is 2 inches. Thus, the velocity measured from Eq. 1 is 11.1 ft/sec ( $2/12/0.015$ ) using the present invention and the actual velocity was 11.2 ft/sec.

Referring to Fig. 9, for the configuration described with Figs. 1,7,8 above, the

25 velocity was measured at various flow rates and plotted against a reference velocity value. A solid line 120 shows the reference velocity, the triangles 122 are the measured data, and a line 124 is a curve fit of the data 122. This illustrates that the present invention predicts the flow velocity within a pipe (or conduit).

The pressure sensors 18,20,22,24 described herein may be any type of

30 pressure sensor, capable of measuring the unsteady (or ac or dynamic) pressures within a pipe, such as piezoelectric, optical, capacitive, piezo-resistive (e.g.,



Wheatstone bridge), accelerometers, velocity measuring devices, displacement measuring devices, etc. If optical pressure sensors are used, the sensors 18-24 may be Bragg grating based pressure sensors, such as that described in copending US Patent Application, Serial No. 08/925,598, entitled "High Sensitivity Fiber Optic Pressure Sensor For Use In Harsh Environments", filed Sept. 8, 1997. Alternatively, the sensors 18-24 may be electrical or optical strain gages attached to or embedded in the outer or inner wall of the pipe which measure pipe wall strain, including microphones, hydrophones, or any other sensor capable of measuring the unsteady pressures within the pipe 12. In an embodiment of the present invention that utilizes fiber optics as the pressure sensors 18-24, they may be connected individually or may be multiplexed along one or more optical fibers using wavelength division multiplexing (WDM), time division multiplexing (TDM), or any other optical multiplexing techniques (discussed more hereinafter).

Referring to Fig. 13, if a strain gage is used as one or more of the pressure sensors 18-24 (Figs. 14-20), it may measure the unsteady (or dynamic or ac) pressure variations  $P_{in}$  inside the pipe 12 by measuring the elastic expansion and contraction, as represented by arrows 350, of the diameter (and thus the circumference as represented by arrows 351) of the pipe 12. In general, the strain gages would measure the pipe wall deflection in any direction in response to unsteady pressure signals inside the pipe 12. The elastic expansion and contraction of pipe 12 is measured at the location of the strain gage as the internal pressure  $P_{in}$  changes, and thus measures the local strain (axial strain, hoop strain or off axis strain), caused by deflections in the directions indicated by arrows 351, on the pipe 12. The amount of change in the circumference is variously determined by the hoop strength of the pipe 12, the internal pressure  $P_{in}$ , the external pressure  $P_{out}$  outside the pipe 12, the thickness  $T_w$  of the pipe wall 352, and the rigidity or modulus of the pipe material. Thus, the thickness of the pipe wall 352 and the pipe material in the sensor sections 14,16 (Fig. 1) may be set based on the desired sensitivity of filter 33 and other factors and may be different from the wall thickness or material of the pipe 12 outside the sensing regions 14,16.

Still with reference to Fig. 13 and Fig. 1, if an accelerometer is used as one or more of the pressure sensors 18-24 (Figs. 14-20), it may measure the unsteady (or

dynamic or ac) pressure variations  $P_{in}$  inside the pipe 12 by measuring the acceleration of the surface of pipe 12 in a radial direction, as represented by arrows 350. The acceleration of the surface of pipe 12 is measured at the location of the accelerometer as the internal pressure  $P_{in}$  changes and thus measures the local elastic dynamic radial response of the wall 352 of the pipe. The magnitude of the acceleration is variously determined by the hoop strength of the pipe 12, the internal pressure  $P_{in}$ , the external pressure  $P_{out}$  outside the pipe 12, the thickness  $T_w$  of the pipe wall 352, and the rigidity or modulus of the pipe material. Thus, the thickness of the pipe wall 352 and the pipe material in the sensor sections 14,16 (Fig. 1) may be set based on the desired sensitivity of filter 33 and other factors and may be different from the wall thickness or material of the pipe 12 outside the sensing region 14. Alternatively, the pressure sensors 18-24 may comprise a radial velocity or displacement measurement device capable of measuring the radial displacement characteristics of wall 352 of pipe 12 in response to pressure changes caused by unsteady pressure signals in the pipe 12.

Referring to Figs. 14,15,16, if an optical strain gage is used, the ac pressure sensors 18-24 may be configured using an optical fiber 300 that is coiled or wrapped around and attached to the pipe 12 at each of the pressure sensor locations as indicated by the coils or wraps 302,304,306,308 for the pressures  $P_1, P_2, P_3, P_4$ , respectively. The fiber wraps 302-308 are wrapped around the pipe 12 such that the length of each of the fiber wraps 302-308 changes with changes in the pipe hoop strain in response to unsteady pressure variations within the pipe 12 and thus internal pipe pressure is measured at the respective axial location. Such fiber length changes are measured using known optical measurement techniques as discussed hereinafter. Each of the wraps measures substantially the circumferentially averaged pressure within the pipe 12 at a corresponding axial location on the pipe 12. Also, the wraps provide axially averaged pressure over the axial length of a given wrap. While the structure of the pipe 12 provides some spatial filtering of short wavelength disturbances, we have found that the basic principle of operation of the invention remains substantially the same as that for the point sensors described hereinbefore.

Referring to Fig. 14, for embodiments of the present invention where the wraps 302,304,306,308 are connected in series, pairs of Bragg gratings (310,312), (314,316), (318,320), (322,324) may be located along the fiber 300 at opposite ends of each of the wraps 302,304,306,308, respectively. The grating pairs are used to  
5 multiplex the pressure signals  $P_1, P_2, P_3, P_4$  to identify the individual wraps from optical return signals. The first pair of gratings 310,312 around the wrap 302 may have a common reflection wavelength  $\lambda_1$ , and the second pair of gratings 314,316 around the wrap 304 may have a common reflection wavelength  $\lambda_2$ , but different from that of the first pair of gratings 310,312. Similarly, the third pair of gratings 318,320 around the  
10 wrap 306 have a common reflection wavelength  $\lambda_3$ , which is different from  $\lambda_1, \lambda_2$ , and the fourth pair of gratings 322,324 around the wrap 308 have a common reflection wavelength  $\lambda_4$ , which is different from  $\lambda_1, \lambda_2, \lambda_3$ .

Referring to Fig. 15, instead of having a different pair of reflection wavelengths associated with each wrap, a series of Bragg gratings 360-368 with only  
15 one grating between each of the wraps 302-308 may be used each having a common reflection wavelength  $\lambda_1$ .

Referring to Figs. 14 and 15 the wraps 302-308 with the gratings 310-324 (Fig.14) or with the gratings 360-368 (Fig.15) may be configured in numerous known ways to precisely measure the fiber length or change in fiber length, such as an  
20 interferometric, Fabry Perot, time-of-flight, or other known arrangements. An example of a Fabry Perot technique is described in US Patent. No. 4,950,883 entitled "Fiber Optic Sensor Arrangement Having Reflective Gratings Responsive to Particular Wavelengths", to Glenn. One example of time-of-flight (or Time-Division-Multiplexing; TDM) would be where an optical pulse having a wavelength is  
25 launched down the fiber 300 and a series of optical pulses are reflected back along the fiber 300. The length of each wrap can then be determined by the time delay between each return pulse.

Alternatively, a portion or all of the fiber between the gratings (or including the gratings, or the entire fiber, if desired) may be doped with a rare earth dopant  
30 (such as erbium) to create a tunable fiber laser, such as is described in US Patent No.

5,317,576, "Continuously Tunable Single Mode Rare-Earth Doped Laser Arrangement", to Ball et al or US Patent No. 5,513,913, "Active Multipoint Fiber Laser Sensor", to Ball et al, or US Patent No. 5,564,832, "Birefringent Active Fiber Laser Sensor", to Ball et al, which are incorporated herein by reference.

5           While the gratings 310-324 are shown oriented axially with respect to pipe 12, in Figs. 14,15, they may be oriented along the pipe 12 axially, circumferentially, or in any other orientations. Depending on the orientation, the grating may measure deformations in the pipe wall 352 with varying levels of sensitivity. If the grating reflection wavelength varies with internal pressure changes, such variation may be  
10           desired for certain configurations (e.g., fiber lasers) or may be compensated for in the optical instrumentation for other configurations, e.g., by allowing for a predetermined range in reflection wavelength shift for each pair of gratings. Alternatively, instead of each of the wraps being connected in series, they may be connected in parallel, e.g., by using optical couplers (not shown) prior to each of the wraps, each coupled to the  
15           common fiber 300.

          Referring to Fig. 16, alternatively, the sensors 18-24 may also be formed as individual non-multiplexed interferometric sensor by wrapping the pipe 12 with the wraps 302-308 without using Bragg gratings where separate fibers 330,332,334,336 may be fed to the separate wraps 302,304,306,308, respectively. In this particular  
20           embodiment, known interferometric techniques may be used to determine the length or change in length of the fiber 10 around the pipe 12 due to pressure changes, such as Mach Zehnder or Michaelson Interferometric techniques, such as that described in US Patent 5,218,197, entitled "Method and Apparatus for the Non-invasive Measurement of Pressure Inside Pipes Using a Fiber Optic Interferometer Sensor" to Carroll.

25           The interferometric wraps may be multiplexed such as is described in Dandridge, et al, "Fiber Optic Sensors for Navy Applications", IEEE, Feb. 1991, or Dandridge, et al, "Multiplexed Interferometric Fiber Sensor Arrays", SPIE, Vol. 1586, 1991, pp176-183. Other techniques to determine the change in fiber length may be used. Also, reference optical coils (not shown) may be used for certain interferometric  
30           approaches and may also be located on or around the pipe 12 but may be designed to be insensitive to pressure variations.

Referring to Figs. 17 and 18, instead of the wraps 302-308 being optical fiber coils wrapped completely around the pipe 12, the wraps 302-308 may have alternative geometries, such as a "radiator coil" geometry (Fig 17) or a "race-track" geometry (Fig. 18), which are shown in a side view as if the pipe 12 is cut axially and laid flat.

5 In this particular embodiment, the wraps 302-208 are not necessarily wrapped 360 degrees around the pipe, but may be disposed over a predetermined portion of the circumference of the pipe 12, and have a length long enough to optically detect the changes to the pipe circumference. Other geometries for the wraps may be used if desired. Also, for any geometry of the wraps described herein, more than one layer of

10 fiber may be used depending on the overall fiber length desired. The desired axial length of any particular wrap is set depending on the characteristics of the ac pressure desired to be measured, for example the axial length of the pressure disturbance caused by a vortex to be measured.

Referring to Figs. 19 and 20, embodiments of the present invention include

15 configurations wherein instead of using the wraps 302-308, the fiber 300 may have shorter sections that are disposed around at least a portion of the circumference of the pipe 12 that can optically detect changes to the pipe circumference. It is further within the scope of the present invention that sensors may comprise an optical fiber 300 disposed in a helical pattern (not shown) about pipe 12. As discussed herein

20 above, the orientation of the strain sensing element will vary the sensitivity to deflections in pipe wall 352 caused by unsteady pressure transients in the pipe 12.

Referring to Fig. 19, in particular, the pairs of Bragg gratings (310,312), (314,316), (318,320), (322,324) are located along the fiber 300 with sections 380-386 of the fiber 300 between each of the grating pairs, respectively. In that case, known

25 Fabry Perot, interferometric, time-of-flight or fiber laser sensing techniques may be used to measure the strain in the pipe, in a manner similar to that described in the aforementioned references.

Referring to Fig. 20, alternatively, individual gratings 370-376 may be disposed on the pipe and used to sense the unsteady variations in strain in the pipe 12

30 (and thus the unsteady pressure within the pipe) at the sensing locations. When a

single grating is used per sensor, the grating reflection wavelength shift will be indicative of changes in pipe diameter and thus pressure.

Any other technique or configuration for an optical strain gage may be used. The type of optical strain gage technique and optical signal analysis approach is not  
5 critical to the present invention, and the scope of the invention is not intended to be limited to any particular technique or approach.

For any of the embodiments described herein, the pressure sensors, including electrical strain gages, optical fibers and/or gratings among others as described herein, may be attached to the pipe by adhesive, glue, epoxy, tape or other suitable  
10 attachment means to ensure suitable contact between the sensor and the pipe 12. The sensors may alternatively be removable or permanently attached via known mechanical techniques such as mechanical fastener, spring loaded, clamped, clamshell arrangement, strapping or other equivalents. Alternatively, the strain gages, including optical fibers and/or gratings, may be embedded in a composite pipe. If desired, for  
15 certain applications, the gratings may be detached from (or strain or acoustically isolated from) the pipe 12 if desired.

It is also within the scope of the present invention that any other strain sensing technique may be used to measure the variations in strain in the pipe, such as highly sensitive piezoresistive, electronic or electric, strain gages attached to or embedded in  
20 the pipe 12. Referring to Fig. 29 different known configurations of highly sensitive piezoresistive strain gages are shown and may comprise foil type gages. Referring to Fig. 30 an embodiment of the present invention is shown wherein pressure sensors 18, 20, comprise strain gages 203. In this particular embodiment strain gages 203 are disposed about a predetermined portion of the circumference of pipe 12. The axial  
25 placement of and separation distance  $X_1$  between pressure sensors 18, 20 are determined as described hereinabove. In particular, the placement is dependent upon the characteristics of the ac pressure desired to be measured, for example the spatial (axial or transverse) length and coherence length of the pressure disturbance caused by the vortex, or unsteady pressure disturbance, to be measured.

30 Referring to Fig. 10, there is shown an embodiment of the present invention comprising three spatial filters, 33,35,37 each comprising a pair of pressure sensors

measuring at total of six unsteady pressures  $P_1$ - $P_6$  (three pairs), each pressure sensor being a plurality (e.g., 10 meters) of fiber optic wraps and the sensors being evenly axially spaced at 1.8 inches apart, on a pipe having an inner diameter of 3.0 inches, a wall thickness of 0.22 inches and made of J55 steel production tubing, is shown. The three spatial filters, 33,35,37 provide spatially filtered ac pressure signals  $P_{as1}$ ,  $P_{as2}$ ,  $P_{as3}$ , respectively.

These ac pressure signals  $P_{sa1}$ ,  $P_{sa2}$ ,  $P_{sa3}$  may be used as input to a variety of devices and used as desired. It is within the scope of the present invention that any number of spatial filters and spatial time filters may be used and that the particular embodiment will dictate the quantity and the spacing (not shown in Fig. 10) between each spatial filter. It is noted that although pressure sensors  $P_1$ - $P_6$  are shown as point sensors it is within the scope of the present invention that the sensors comprise any configuration capable of accurately detecting pressure changes in pipe 12 including fiber optic wraps as described herein.

Referring to Fig. 11, for the configuration of Fig 10, and for a liquid flow mixture of 100% oil at 111.2 gal/minute (or about 5.05 ft/sec for a 3 inch pipe), the invention provides cross-correlation curves 130,132,134. The curves 130,132,134 correspond to velocities of 5.538 ft/sec, 5.541 ft/sec, 5.5822 ft/sec, for the cross-correlation between  $P_{sa1}$  and  $P_{sa2}$  (vel-a),  $P_{sa2}$  and  $P_{sa3}$  (vel-b), and  $P_{sa1}$  and  $P_{sa3}$  (vel-c), for the groups of sensors a,b,c, respectively, shown in Fig. 10.

Referring to Fig. 12, it is shown that the present invention will work over a wide range of oil/water mixtures. In particular, the first two pairs of sensors ( $P_1$ , $P_2$ , and  $P_3$ , $P_4$ ) of Fig. 10 measured the velocity at various flow rates against a reference velocity value. Data points 151-162 are groupings of measured velocity data points derived from the sensors ( $P_1$ , $P_2$ , $P_3$ , $P_4$ ) and are plotted against a reference velocity line 150. The data points 151-162 also show the invention will work for fluid flowing in either direction in the pipe 12. The negative flow data points 151-158 were taken with a fluid of 100% oil and the positive flow data points 159-162 were taken over a range of various oil/water mixtures. Specifically, data points 159 represent 100 individual data points taken at velocities from about 5.2 ft/sec to about 5.7 ft/sec and in oil/water mixtures from 0% to 100% water. Data point 160 represents a single

individual data point taken at a velocity of about 9.9 ft/sec in an oil/water mixture of 0% water. Data point 161 represents a single individual data point taken at velocity of about 13.7 ft/sec in an oil/water mixture of 0% water. Similarly, data points 162 represent 21 individual data points taken at velocities from about 18.0 ft/sec to about 19.0 ft/sec and in oil/water mixtures from 0% to 100% water. The departure of the raw data 151-162 from the reference velocity line 150 is caused, in part, by the fact that the points were not calibrated and that the reference velocity at each point was taken manually by a technician. Had the data points been calibrated and electronically matched to the sensed points the departure from the reference line 150 would not have been as large as depicted in the figure.

The present invention will also work over a wide range of oil/water/gas mixtures. Also, the invention will work for very low flow velocities, e.g., at or below 1 ft/sec (or about 20.03 gal/min, in a 3 inch diameter ID pipe) and has no maximum flow rate limit. Further, the invention will work with the pipe 12 being oriented vertical, horizontal, or any other orientation. Also the invention will work equally well independent of the direction of the flow along the pipe 12.

Referring to Fig. 21, instead of the unsteady pressure sensors 18,20 and the corresponding unsteady pressure signals  $P_1, P_2$  being spaced axially along the pipe 12, the sensors 18,20 may be spaced circumferentially apart at substantially the same axial location. In that case, the spatial filter 33 (Fig. 1) (i.e., the difference between the two signals  $P_1, P_2, P_3, P_4$ ) filters out substantially all one dimensional acoustic waves propagating through the sensing region 14.

Alternatively, referring to Fig. 22, instead of the pressure sensors 18,20 being located directly across from each other, the signal  $P_2$  may be measured at a distance circumferentially closer to the sensor 18, as indicated by a sensor 200. The circumferential distance 53 between the two sensors 18,200 should be large enough to independently measure a propagating vortical pressure field 15 such that the spatial filter 33 output is not zero for the measured vortex 15, i.e., that the circumferential distance 53 is greater than the transverse spatial length of vortex 15. In addition, the distance  $X_1$  (Fig. 1) should be less than or equal to the axial coherence length of the vortex 15 such that the spatial filter output is indicative of a measured vortex 15.



The thickness and rigidity of the outer wall of the pipe 12 is related to the acceptable spacing  $X_1$  (Fig. 1) between the sensors 18,20 of the spatial filter 33. More specifically, the thinner or less rigid the pipe 12 wall, the closer the sensors 18,20 can be to each other.

5           Also, for optimal performance, the distance  $X_1$  between the two sensors 18,20 should be larger than the spatial length of the vortical pressure field 15 such that each of the sensors 18,20 can independently measure the propagating vortical pressure field 15 between the sensors 18,20 at different times (such that the spatial filter 33 output is not zero for the measured vortex 15). Also, the distance  $X_1$  should be within the  
10 coherence length of the vortex 15 such that the spatial filter output is indicative of a measured vortex 15. Also, for optimal performance, the overall length  $L_1$  between the first sensor 18 and the last sensor 24 of the velocity sensing section should be within the coherence length of the vortices 15 desired to be measured. The coherence  
15 length of the vortical flow field 15 is the length over which the vortical flow field remains substantially coherent, which is related to and scales with the diameter of the pipe 12.

Vortices that are sensed by only one of the spatial filters, because either a vortex is generated between the spatial filters or generated outside the spatial filters and decay between them, will be substantially random events (in time and location)  
20 that will not be correlated to the vortices that are sensed by and continuously occurring past both spatial filters and, as such, will not significantly affect the accuracy of the measurement.

Referring to Fig. 24, a particular embodiment of the present invention is shown therein where more than two sensors may be used for one or both of the spatial  
25 filters 33,35. In particular, the summer 44 may have three inputs  $P_1, P_2, P_3$ , from three pressure sensors 220,222,224 where the output signal  $P_{sa1} = P_1 - 2P_2 + P_3$ . For optimal performance, the overall axial length  $L$  of the filter 33 should be within the coherence length of the vortices 15 being measured and the individual spacing between the sensors 220,222,224 should have the same criteria discussed hereinbefore for the  
30 spacing between two sensors 18,20.

Referring to Fig 32, instead of using four pressure sensors to make the spatial filters 33,35 three pressure sensors 600,602,604 may be used where the middle sensor 602 is used for both the spatial filters 33,35.

Referring to Figs. 28-31, instead of measuring the unsteady pressures  $P_1$ - $P_4$  on the exterior of the pipe 12, the invention will also work when the unsteady pressures are measured inside the pipe 12. In particular, the pressure sensors 18,20 that measure the pressures  $P_1$ , $P_2$ , may be located anywhere within the pipe 12, having the same constraints discussed hereinbefore for the exterior measurements. Any technique may be used to measure the unsteady pressures inside the pipe 12.

Referring to Figs. 25-27, the invention may also measure the velocity of flow outside a pipe or tube 400. In that case, the tube 400 may be placed within the pipe 12 and the pressures  $P_1$ - $P_4$  measured at the outside of the tube 400. Any technique may be used to measure the unsteady pressures  $P_1$ - $P_4$  outside the tube 400.

Referring to Fig. 25, for example, the tube 400 may have the optical wraps 302-308 wrapped around the tube 400 at each sensing location. Alternatively, any of the strain measurement or displacement, velocity or accelerometer sensors or techniques described herein may be used on the tube 400. Referring to Fig. 26, alternatively, the pressures  $P_1$ - $P_4$  may be measured using direct pressure measurement sensors or techniques described herein. Any other type of unsteady pressure sensors 18-24 may be used to measure the unsteady pressures within the pipe 12.

Alternatively, referring to Fig. 27, hydrophones 402-408 may be used to sense the unsteady pressures within the pipe 12. In that case, the hydrophones 402-408 may be located in the tube 400 for ease of deployment or for other reasons. The hydrophones 402-408 may be fiber optic, electronic, piezoelectric or other types of hydrophones. If fiber optic hydrophones are used, the hydrophones 402-408 may be connected in series or parallel along the common optical fiber 300.

The tube 400 may be made of any material that allows the unsteady pressure sensors to measure the pressures  $P_1$ - $P_4$  and may be hollow, solid, or gas filled or fluid filled. One example of a dynamic pressure sensor is described in co-pending commonly-owned US Patent Application, Serial No. (Attorney Docket No. 712-2.40/CC-0067) entitled "Mandrel Wound Fiber Optic Pressure Sensor", filed June 4,

1999. Also, the end 422 of the tube 400 may be closed or open. If the end 422 is closed, the flow path would be around the end 422 as indicated by lines 424. If the end 422 is open, the flow path would be through the inside of the tube, as indicated by a line 426 and the pressure would be measured inside of the pipe 12. For oil and gas well applications, the tube 400 may be coiled tubing having the pressure sensors for sensing  $P_1$ - $P_4$  inside the tubing 400.

Although the invention has been described with respect to the detection of certain types of unsteady flow fields and the pressure disturbances associated therewith, it should be understood that the invention will also detect any unsteady stochastic flow field and its associated pressure field that propagates within the flow, provided the spatial filters have a separation within the acceptable coherence length of the flow field to be measured and the sensor spacing within each spatial filter is longer than a characteristic spatial length of the disturbance. Some examples of such other stochastic flow fields are gas bubbles, gas slugs, particles, or chunks of material, which may travel in the flow at different rates than the mean flow velocity, thereby creating a traveling pressure disturbance, which exhibits a velocity slip between it and the other constituents in the mixture.

Accordingly, the invention may be used to detect such different flow rates within the same mixture (e.g., the flow rate of an unsteady pressure field within the mixture). Also, such unsteady flow fields, when traveling at different rates from other portions of the mixture, may also shed vortices in the flow that may propagate with the flow and be detected as an unsteady flow field by the present invention.

Referring to Fig. 33, there is shown an embodiment of the present invention in an oil or gas well application, the sensing section 10 may be connected to or part of production tubing 502 within a well 500. An outer housing, sheath, or cover 512 may be located over the sensors 18-24 and attached to the pipe (not shown) at the axial ends to protect the sensors 18-24 (or fibers) from damage during deployment, use, or retrieval, and/or to help isolate the sensors from external pressure effects that may exist outside the pipe 12, and/or to help isolate ac pressures in the pipe 12 from ac pressures outside the pipe 12. The sensors 18-24 are connected to a cable 506 which

may comprise the optical fiber 300 (Fig. 1) and is connected to a transceiver/converter 510 located outside the well.

When optical sensors are used, the transceiver/converter 510 may be used to receive and transmit optical signals to the sensors 18-24 and provides output signals indicative of the pressure  $P_1$ - $P_4$  at the sensors 18-24 on the lines 30-36, respectively. Also, the transceiver/ converter 510 may be part of the Velocity Logic 40. The transceiver/converter 510 may be any device that performs the corresponding functions described herein. In particular, the transceiver/ converter 510 together with the optical sensors described hereinbefore may use any type of optical grating-based measurement technique, e.g., scanning interferometric, scanning Fabry Perot, acousto-optic-tuned filter (AOTF), optical filter, time-of-flight, etc., having sufficient sensitivity to measure the ac pressures within the pipe, such as that described in one or more of the following references: A. Kersey et al., "Multiplexed fiber Bragg grating strain-sensor system with a Fabry-Perot wavelength filter", Opt. Letters, Vol. 18, No. 16, Aug. 1993, US Patent No. 5,493,390, issued Feb. 20, 1996 to Mauro Verasi, et al., US Patent No. 5,317,576, issued May 31, 1994, to Ball et al., US Patent No. 5,564,832, issued Oct. 15, 1996 to Ball et al., US Patent No. 5,513,913, issued May 7, 1996, to Ball et al., US Patent No. 5,426,297, issued June 20, 1995, to Dunphy et al., US Patent No. 5,401,956, issued March 28, 1995 to Dunphy et al., US Patent No. 4,950,883, issued Aug. 21, 1990 to Glenn, US Patent No. 4,996,419, issued Feb. 26, 1991 to Morey all of which are incorporated by reference. Also, the pressure sensors described herein may operate using one or more of the techniques described in the aforementioned references.

A plurality of the sensors 10 of the present invention may be connected to a common cable and multiplexed together using any known multiplexing technique.

It should be understood that any of the features, characteristics, alternatives or modifications described regarding a particular embodiment herein may also be applied, used, or incorporated with any other embodiment described herein.

Although the invention has been described and illustrated with respect to exemplary embodiments thereof, the foregoing and various other additions and

omissions may be made therein and thereto without departing from the spirit and scope of the present invention.

5

### Claims

#### What is claimed is:

1. An apparatus for measuring a velocity of a fluid moving in a pipe, comprising:  
5 a first filter which measures a vortical pressure field at a first axial location along the pipe and provides a first pressure signal indicative of said vortical pressure field; and  
a second filter which measures said vortical pressure field at a second axial location along the pipe and provides a second pressure signal indicative of said  
10 vortical pressure field;  
a signal processor, responsive to said first and said second pressure signals, which provides a velocity signal indicative of a velocity of the said vortical pressure field moving in the pipe.
- 15 2. The apparatus of claim 1 wherein said velocity signal is related to a velocity of said fluid moving in said pipe.
3. The apparatus of claim 1 wherein said velocity signal is indicative of the  
20 velocity of said fluid moving in said pipe.
4. The apparatus of claim 1 further comprising a volumetric flow meter wherein said signal processor provides a flow signal indicative of the volumetric flow rate of said fluid flowing in said pipe.
- 25 5. The apparatus of claim 1, wherein said first and said second filters filter out wavelengths associated with an acoustic pressure field and passes wavelengths associated with said vortical pressure field.
6. The apparatus of claim 5, wherein said first filter comprises a first spatial  
30 filter; and said second filter comprises a second spatial filter.

7. The apparatus of claim 1, wherein said vortical pressure field comprises an inhomogeneous pressure field.
8. The apparatus of claim 7, wherein said first and said second filters filter out  
5 wavelengths associated with an acoustic pressure field and passes wavelengths associated with said inhomogeneous pressure field.
9. The apparatus of claim 6, wherein said first and second spatial filters filter out wavelengths above a predetermined wavelength.
- 10
10. The apparatus of claim 6, wherein said first and second spatial filters filter out wavelengths above a predetermined wavelength and frequencies below a predetermined frequency.
- 15
11. The apparatus of claim 6, wherein:  
said first spatial filter comprises at least a first and a second unsteady pressure sensors disposed a predetermined first distance apart from each other; and  
said second spatial filter comprises at least a third and a fourth unsteady pressure sensors disposed a predetermined second distance apart from each other.
- 20
12. The apparatus of claim 11 wherein said at least one of said pressure sensors comprises a strain gage disposed on a surface of the pipe.
13. The apparatus of claim 12 wherein said surface is an outer surface of said pipe.
- 25
14. The apparatus of claim 11 wherein said at least one of said pressure sensors comprises a fiber optic pressure sensor.
15. The apparatus of claim 14 wherein fiber optic pressure sensor comprises at  
30 least one Bragg grating.

16. The apparatus of claim 12 wherein said strain gage comprises a fiber optic strain gage.
17. The apparatus of claim 16 wherein said fiber optic strain gage comprises at least one Bragg grating.
18. The apparatus of claim 1 wherein said signal processor comprises logic which calculates a cross-correlation between said first and said second inhomogeneous pressure signals and provides a time delay signal indicative of the time it takes for said vortical pressure field to move from said first location to said second location.
19. The apparatus of claim 18 wherein said signal processor comprises logic responsive to said time delay signal which provides an inhomogeneous velocity signal indicative of the velocity of said vortical pressure field moving in said pipe.
20. The apparatus of claim 18 wherein said signal processor comprises logic responsive to said time delay signal which provides said velocity signal indicative of the velocity of said fluid moving in said pipe.
21. The apparatus of claim 1 wherein said signal processor comprises filter logic responsive to said first and said second pressure signals, which filters out a predetermined range of frequencies.
22. The apparatus of claim 21 wherein said filter logic comprises a band pass filter.
23. A method for measuring a velocity of a fluid moving in a pipe, the method comprising:
- a) measuring a vortical pressure field at a first location along the pipe and providing a first vortical pressure signal indicative of said vortical pressure field;



- b) measuring said vortical pressure field at a second location along the pipe and providing a second vortical pressure signal indicative of said vortical pressure field, said first and said second locations being an axial distance apart; and
- c) calculating the velocity using said first and said second vortical pressure signals.
- 5
24. The method of claim 23, wherein said calculating step (c) comprises:
- d) calculating a cross-correlation of said first and said second pressure signals to obtain a time delay signal indicative of the time it takes for said vortical pressure field to move from said first location to said second location.
- 10
25. The method of claim 24, wherein said calculating step (d) comprises:
- e) calculating a velocity signal from said time delay signal.
- 15
26. The method of claim 25, wherein said calculating step (e) comprises:
- f) dividing said axial distance between said measurement locations by said time delay signal.
- 20
27. The method of claim 23 wherein:
- said measuring step (a) comprises:
- measuring a first unsteady pressure and a second unsteady pressure;
- subtracting said second unsteady pressure from said first unsteady pressure to form said first vortical pressure signal; and
- said measuring step (b) comprises:
- 25 measuring a third unsteady pressure and a fourth unsteady pressure;
- and
- subtracting said fourth unsteady pressure from said third unsteady pressure to form said second vortical pressure signal.

- 30 28. The method of claim 23 wherein:

said first vortical pressure signal is indicative of wavelengths associated with a vortical pressure field and not associated with an acoustic pressure field at said first location; and

5           said second vortical pressure signal is indicative of wavelengths associated with said vortical pressure field and not associated with an acoustic pressure field at said second location.

29.    The method of claim 23 wherein said vortical pressure field comprises an inhomogeneous pressure field.
- 10
30.    The method of claim 23 wherein said measuring steps (a) and (b) comprise measuring a strain of the pipe.
31.    The method of claim 27 wherein said step of measuring said first and said
- 15   second unsteady pressures comprises measuring a strain of the pipe.
32.    The method of claim 27 wherein said step of measuring said third and said fourth unsteady pressures comprises measuring a strain of the pipe.
- 20   33.    The method of claim 23 further comprising calculating the volumetric flow rate of said fluid.

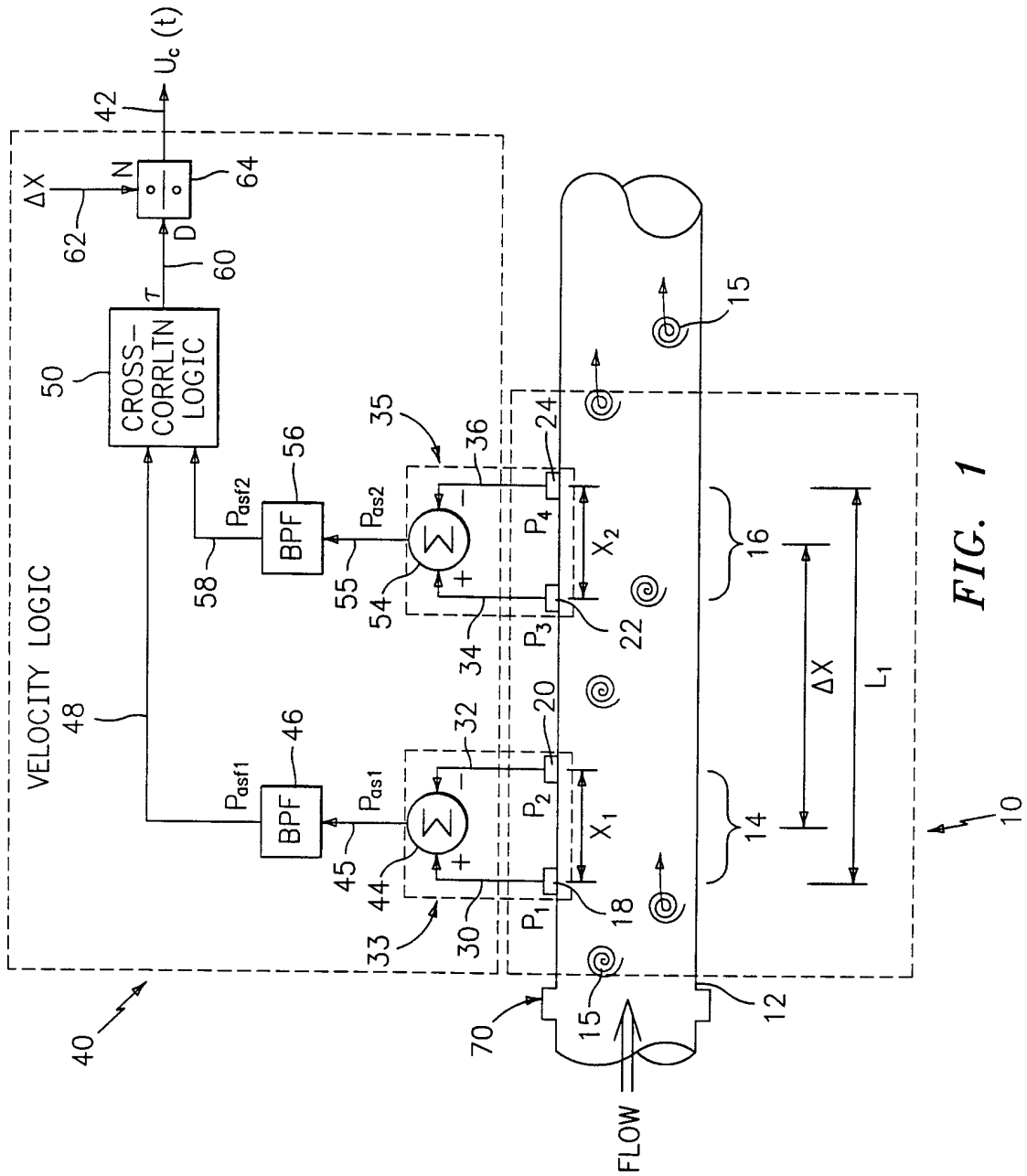
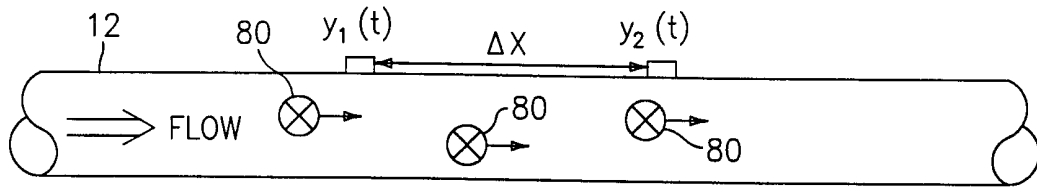
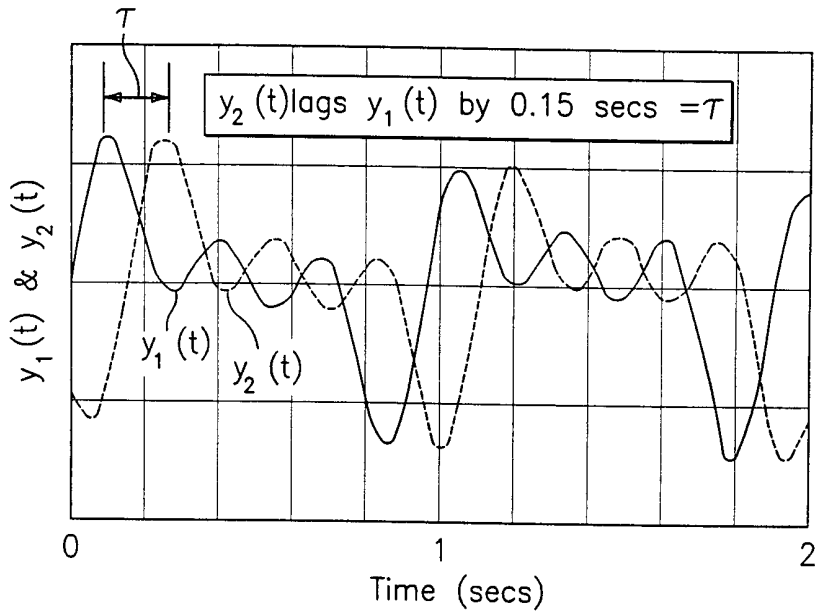

FIG. 1



**FIG. 2**  
(PRIOR ART)



**FIG. 3**  
(PRIOR ART)

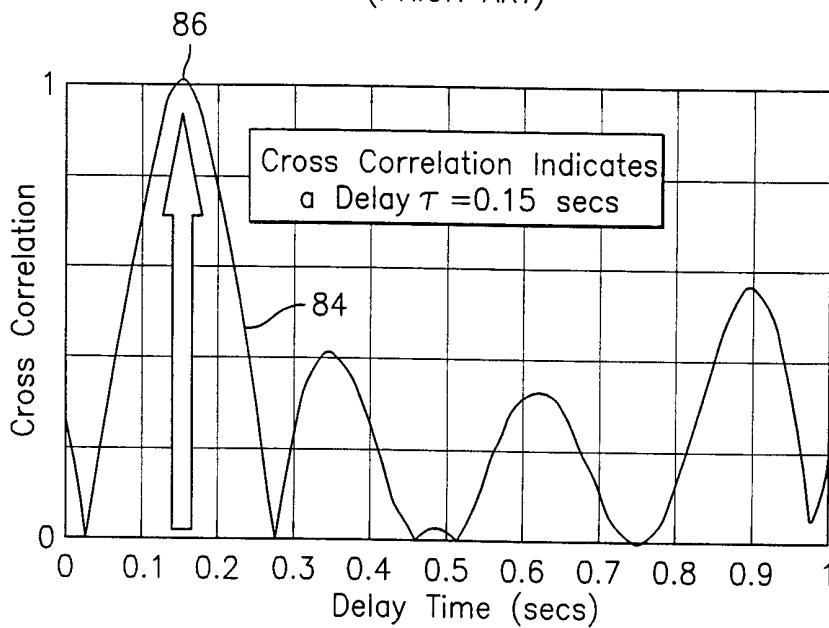

**FIG. 4**  
(PRIOR ART)

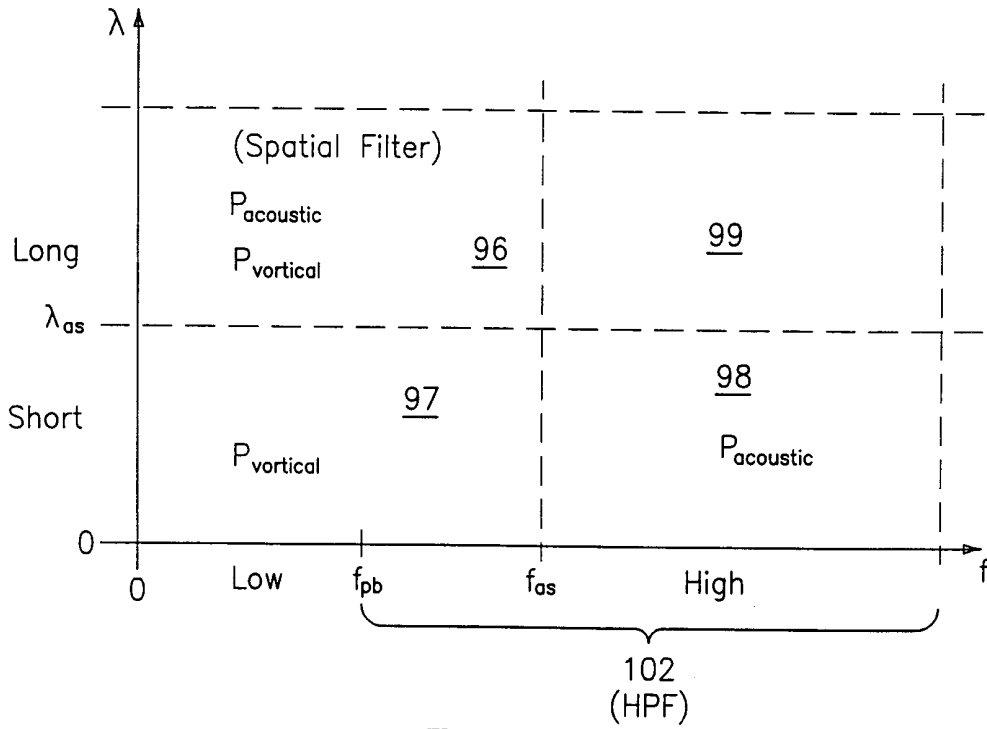
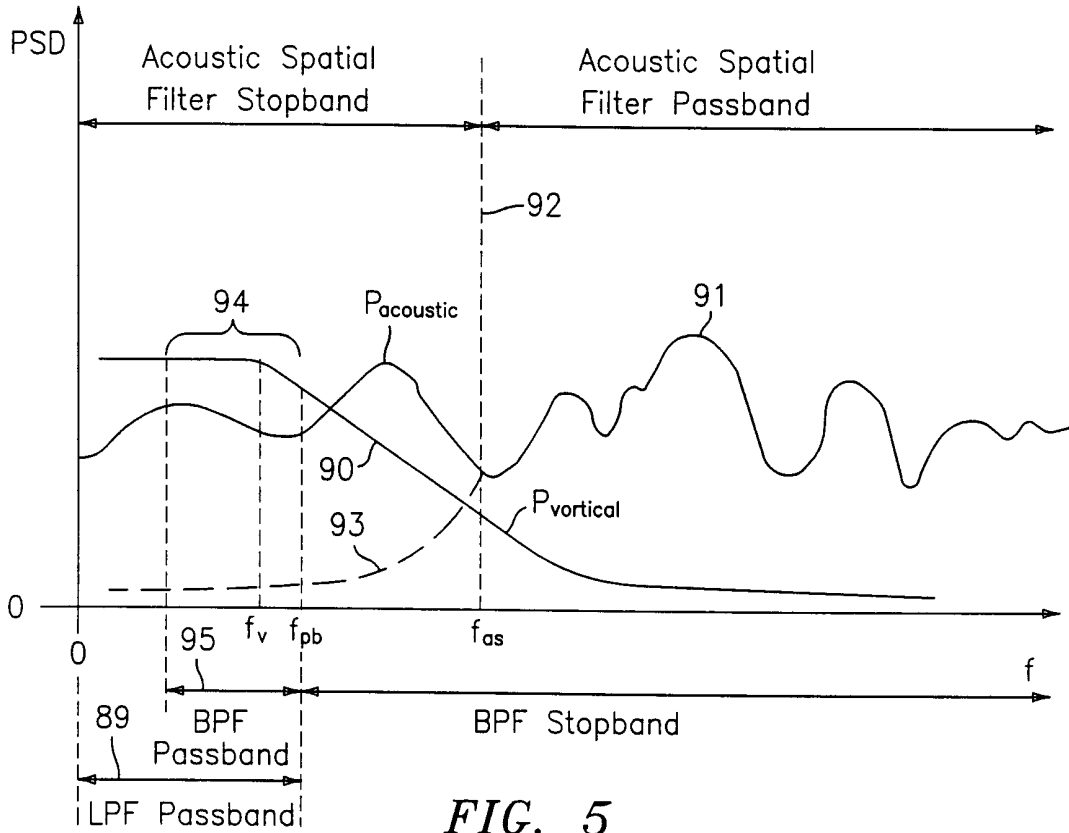

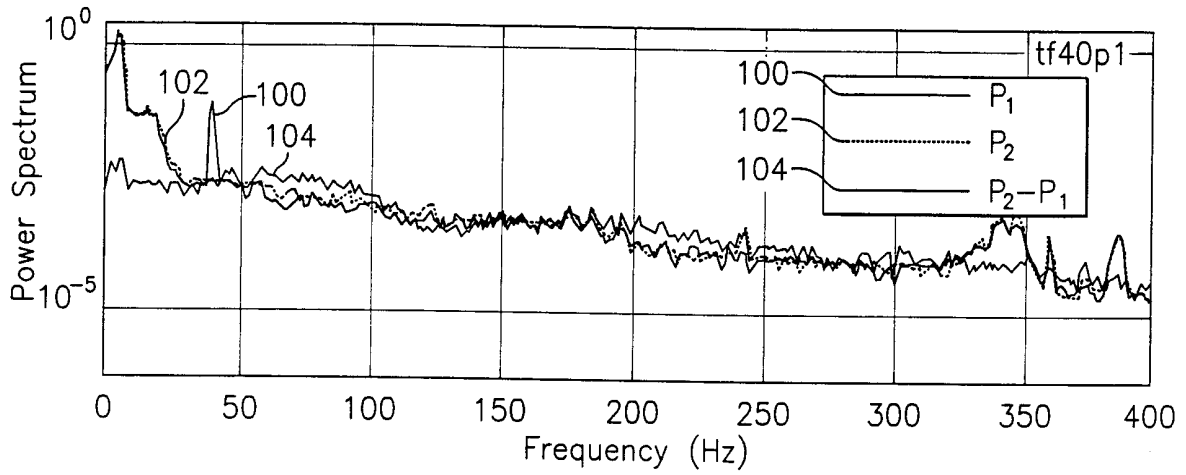

FIG. 7

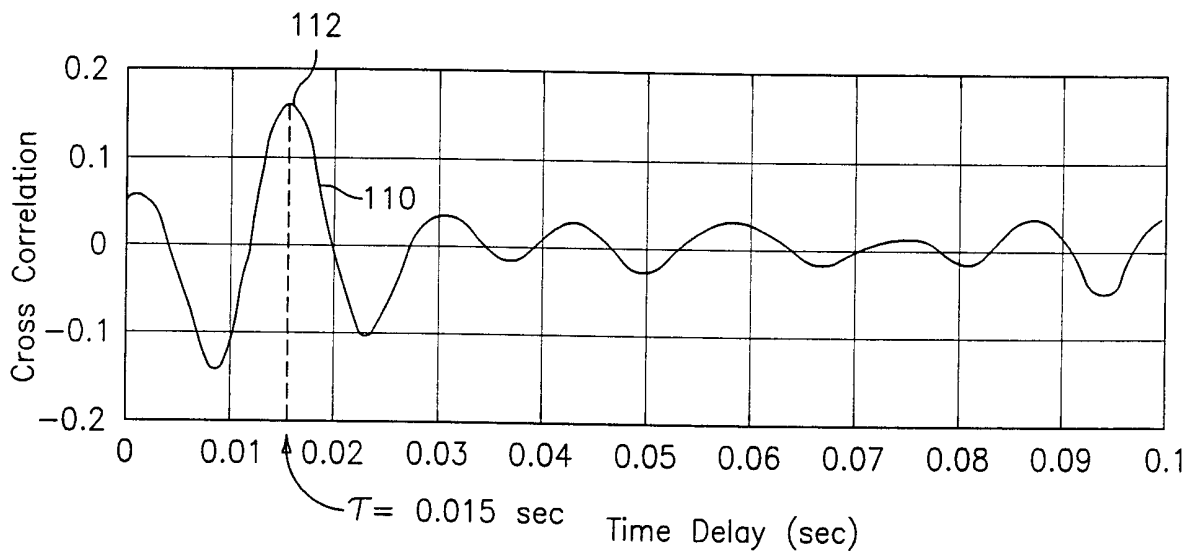
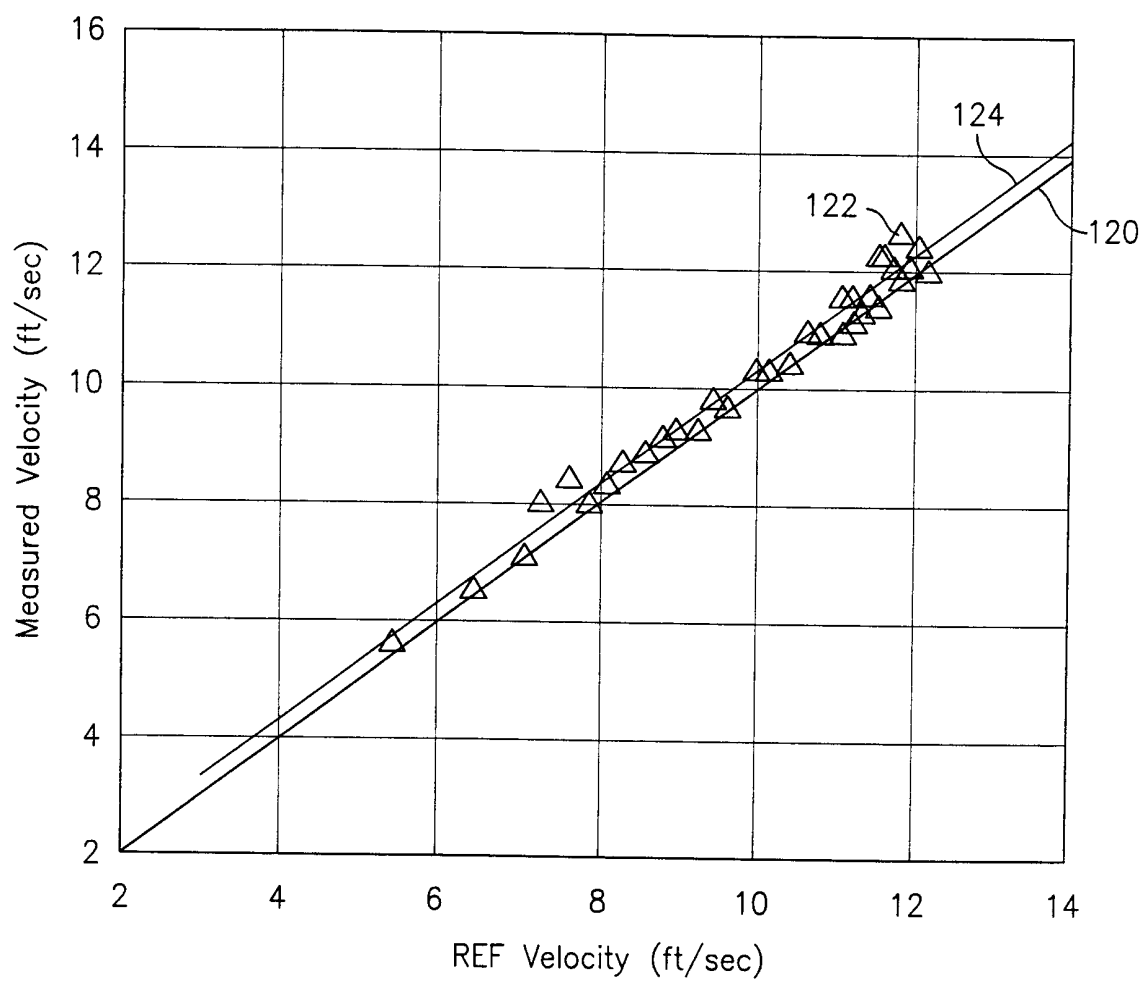

FIG. 8



**FIG. 9**

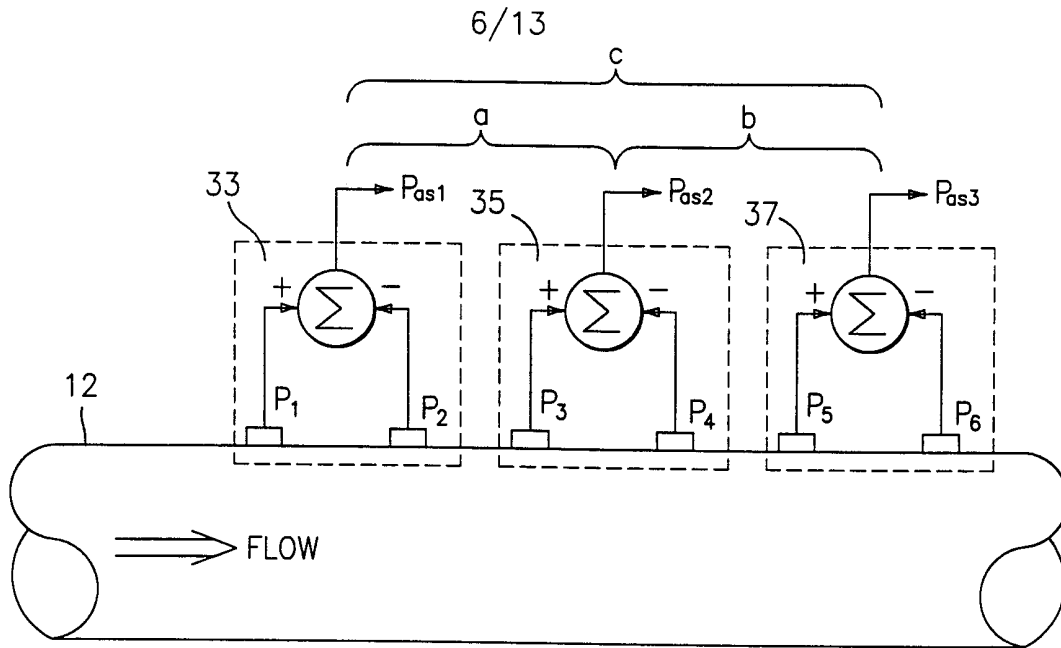

FIG. 10

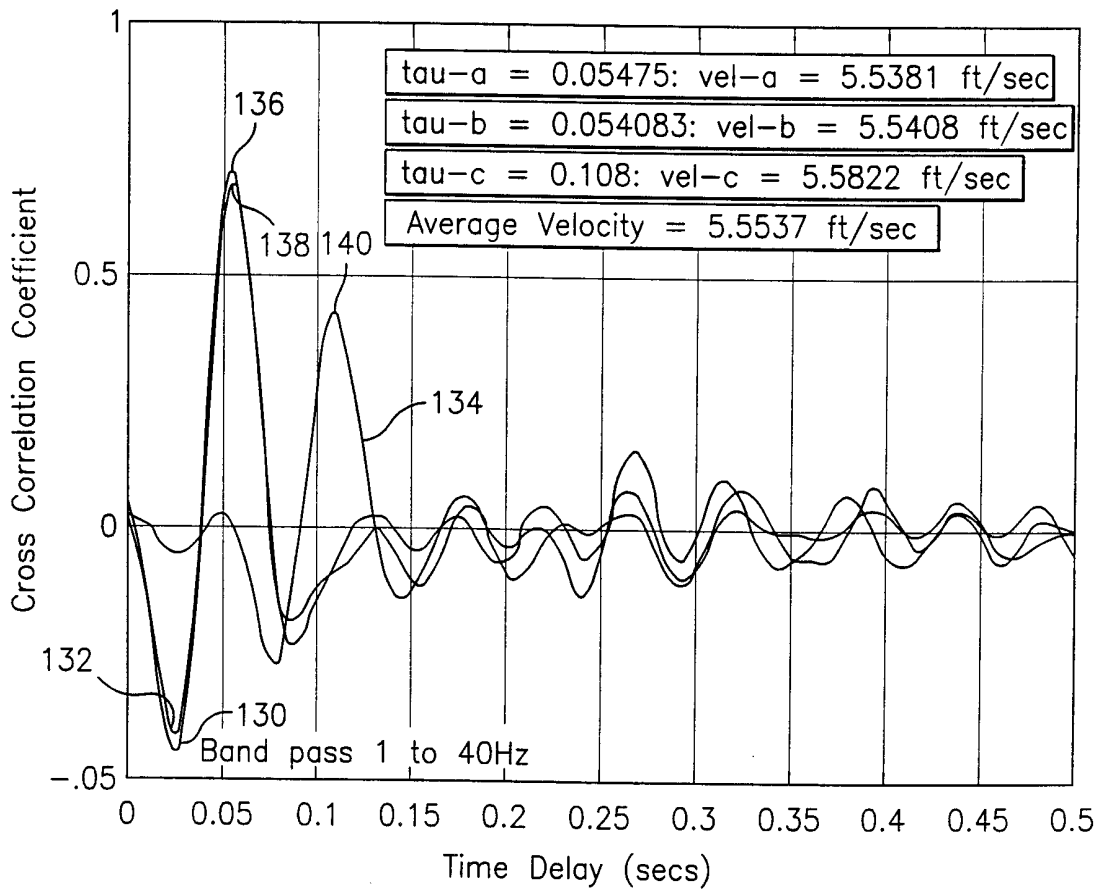
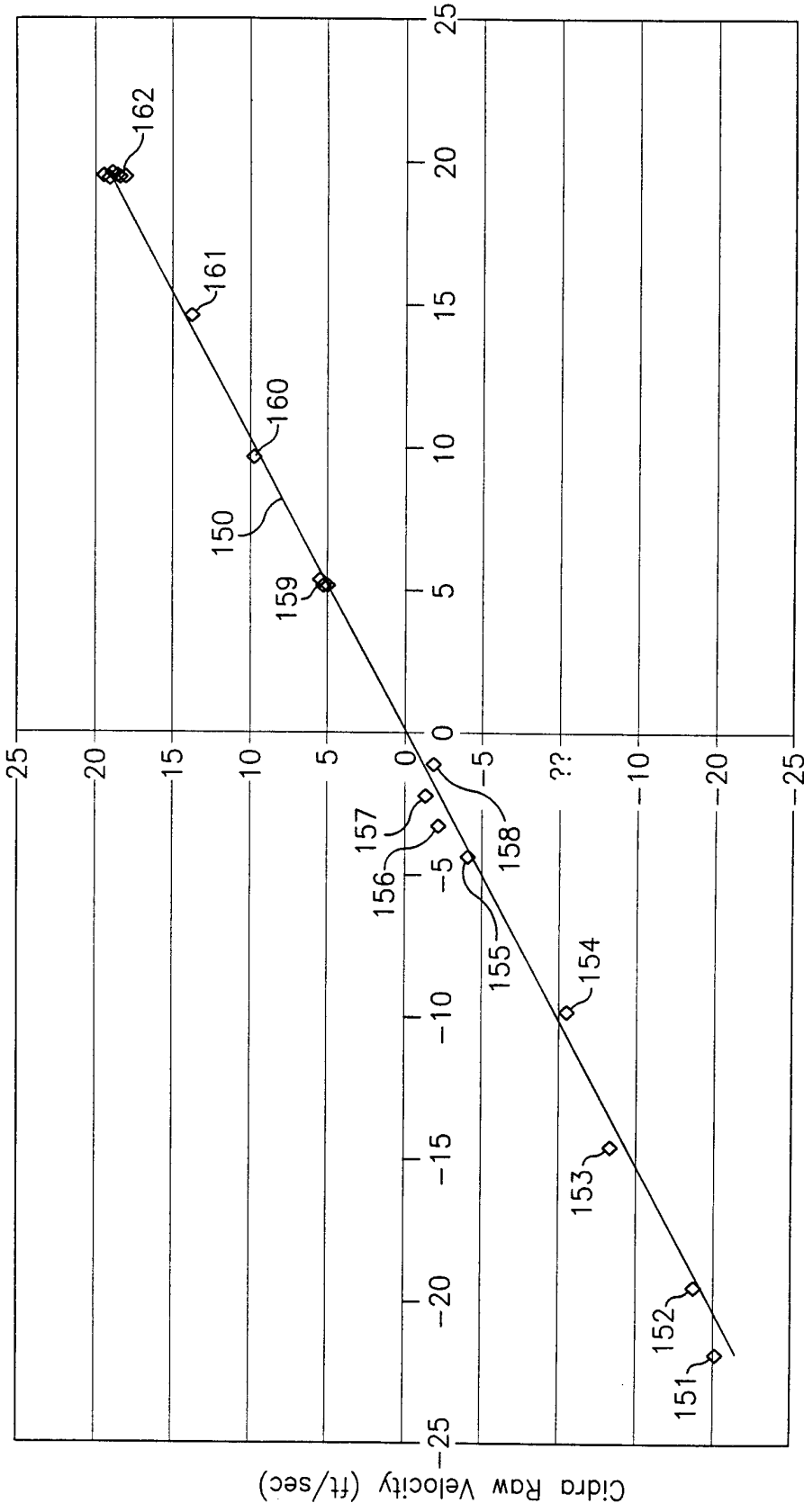

FIG. 11





Reference Velocity (ft/sec)

**FIG. 12**

8/13

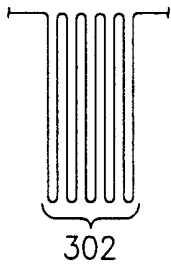

FIG. 17

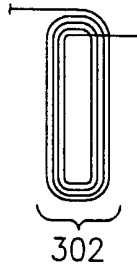

FIG. 18

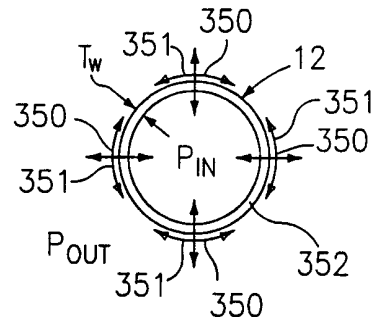

FIG. 13

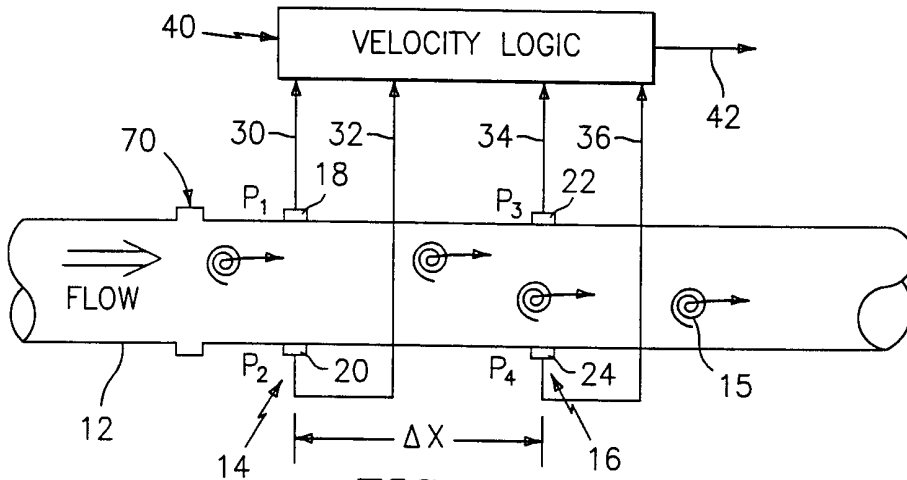

FIG. 21

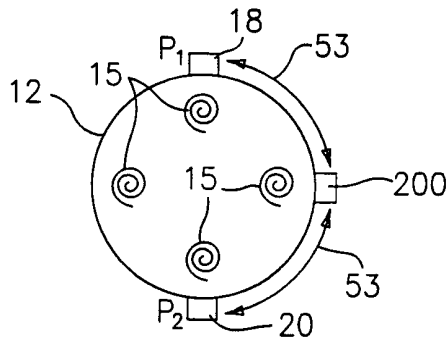

FIG. 22

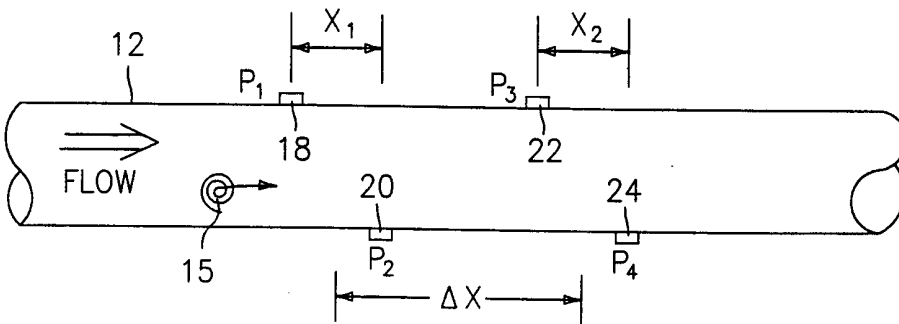

FIG. 23

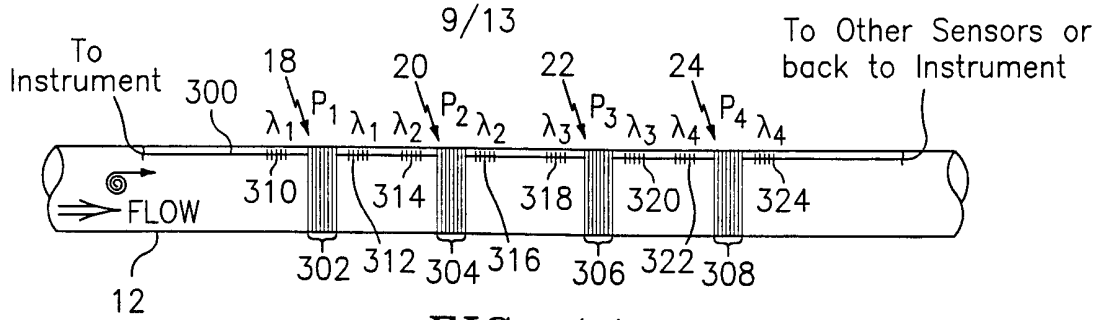

FIG. 14

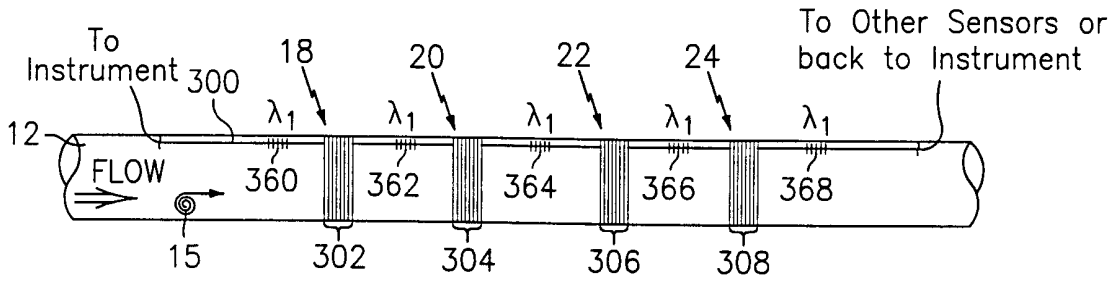

FIG. 15

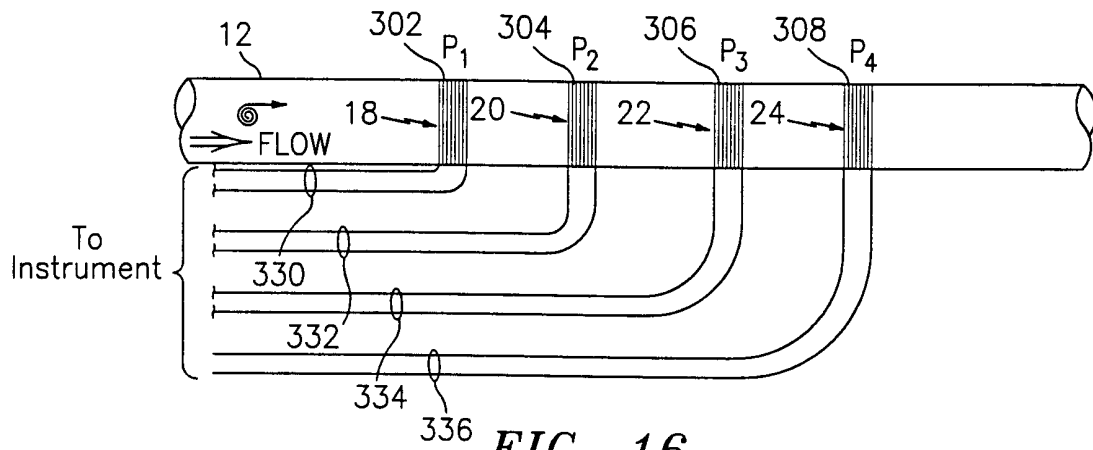

FIG. 16

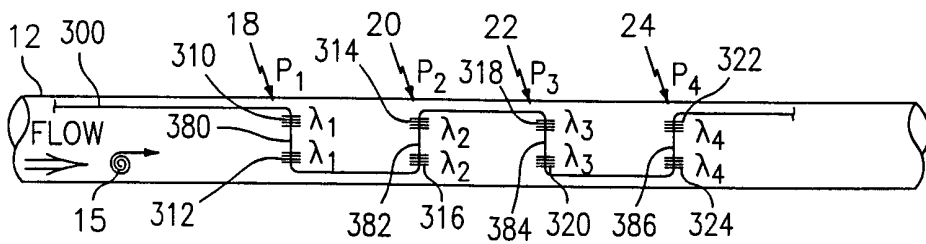

FIG. 19

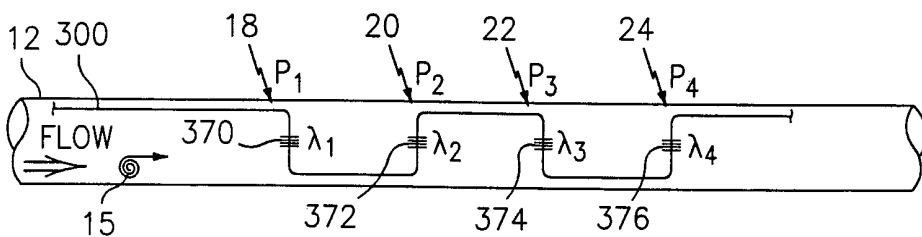

FIG. 20

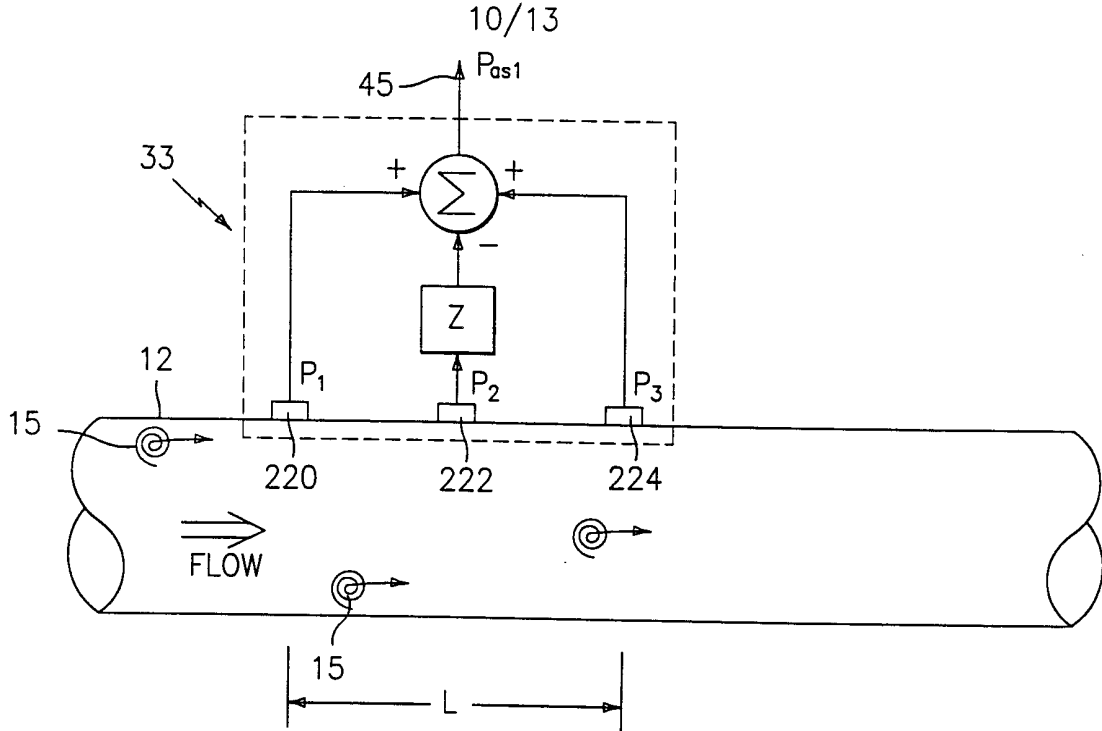

FIG. 24

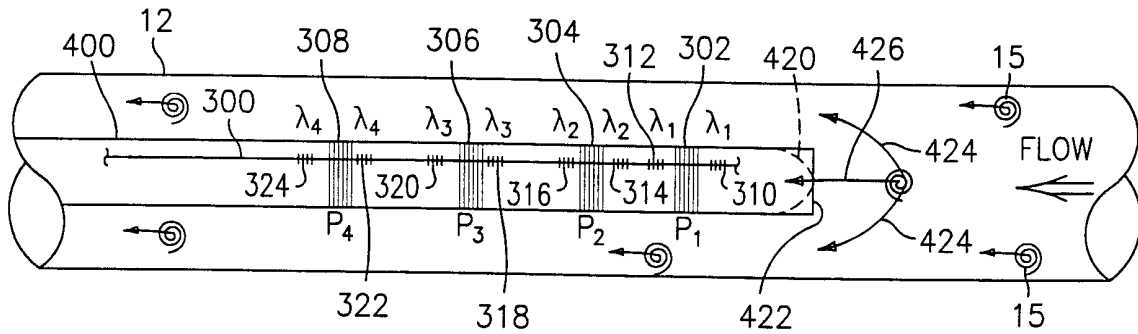

FIG. 25

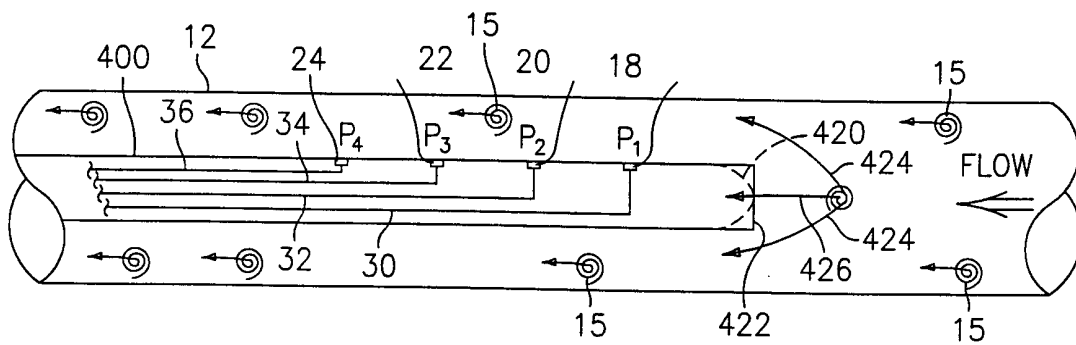

FIG. 26

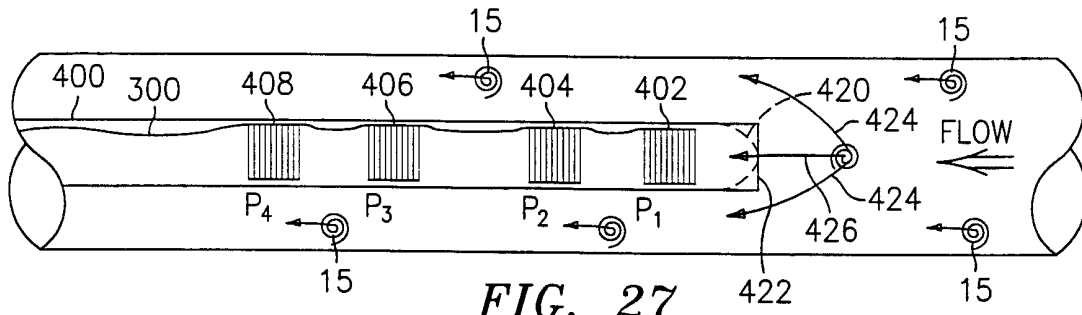

FIG. 27

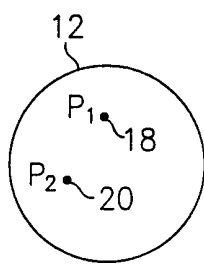

FIG. 28

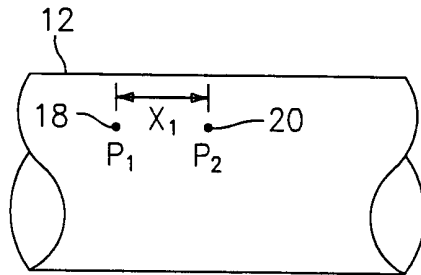

FIG. 29

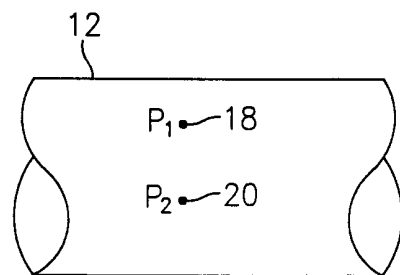

FIG. 30

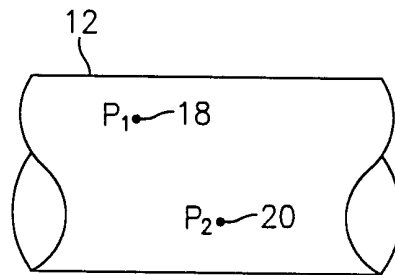

FIG. 31

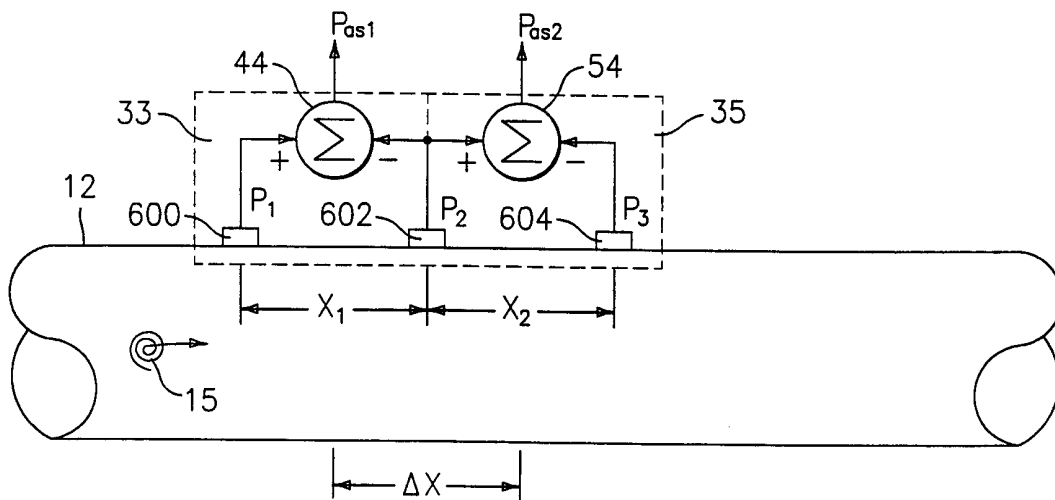

FIG. 32

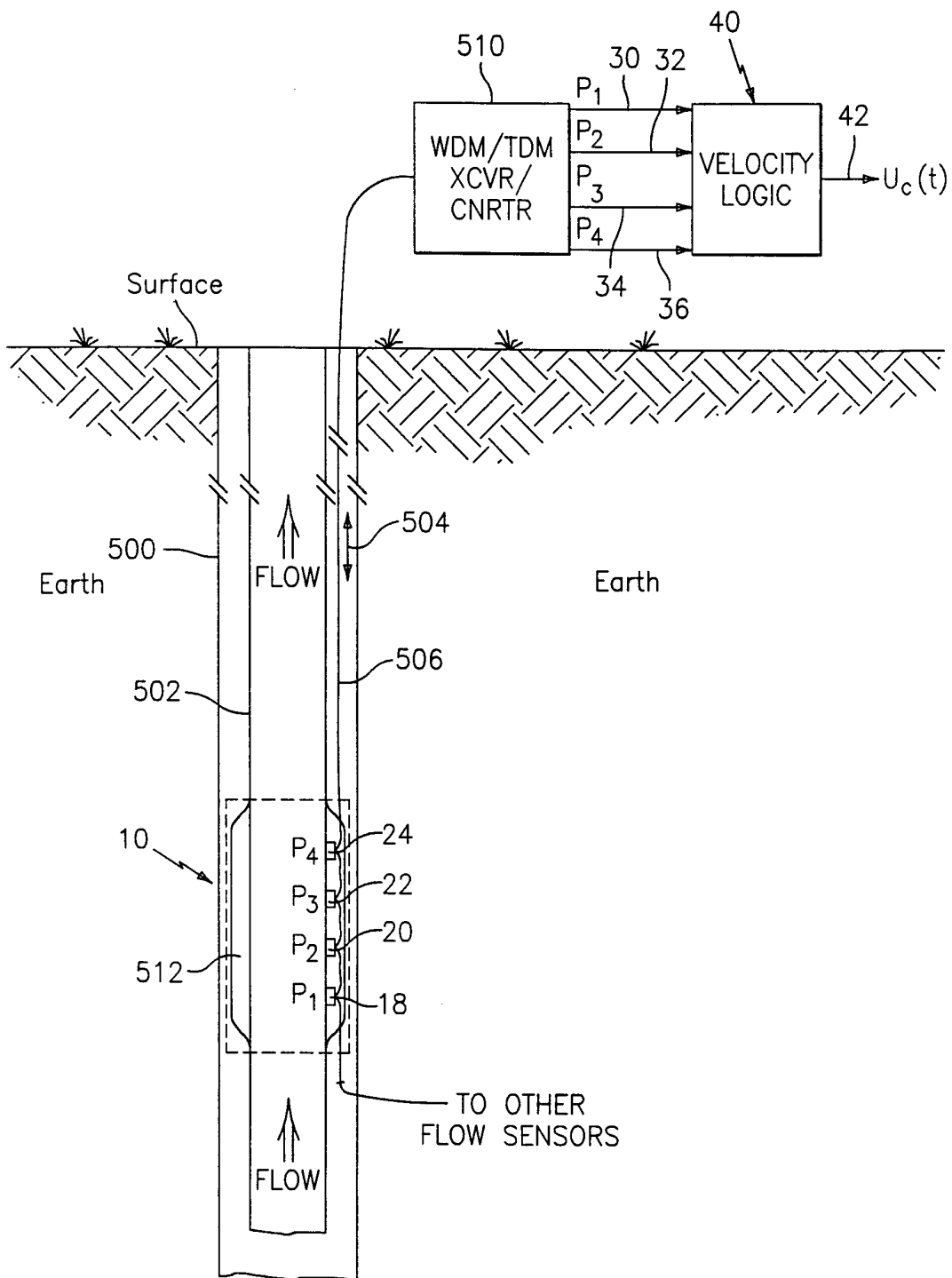

FIG. 33

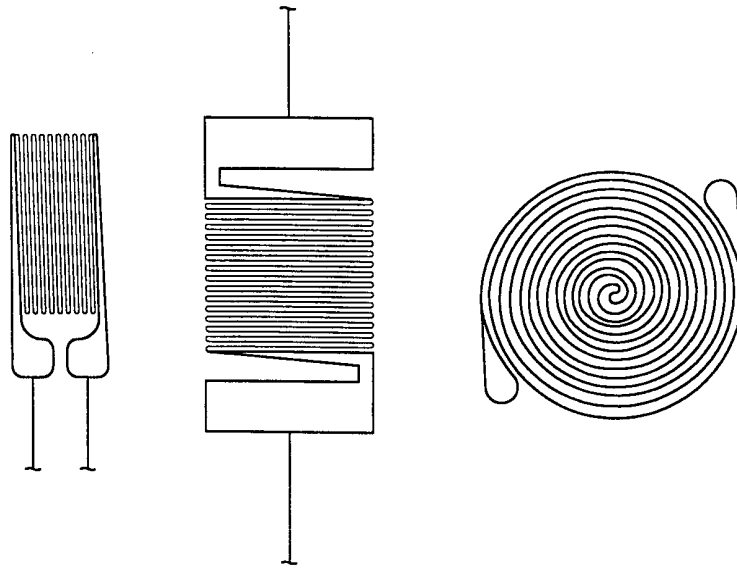

FIG. 34

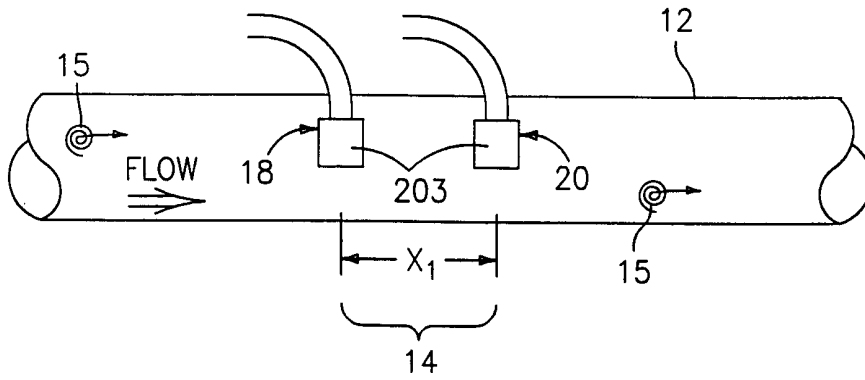

FIG. 35

# INTERNATIONAL SEARCH REPORT

International Application No

PCT/US 00/17640

**A. CLASSIFICATION OF SUBJECT MATTER**  
 IPC 7 G01F1/74 G01F1/712 G01F1/708

According to International Patent Classification (IPC) or to both national classification and IPC

**B. FIELDS SEARCHED**

Minimum documentation searched (classification system followed by classification symbols)

IPC 7 G01F

Documentation searched other than minimum documentation to the extent that such documents are included in the fields searched

Electronic data base consulted during the international search (name of data base and, where practical, search terms used)

EPO-Internal

**C. DOCUMENTS CONSIDERED TO BE RELEVANT**

Category	Citation of document, with indication, where appropriate, of the relevant passages	Relevant to claim No.
X	MESCH F: "SPEED AND FLOW MEASUREMENT BY AN INTELLIGENT CORRELATION SYSTEM" ADVANCES IN INSTRUMENTATION AND CONTROL, US, INSTRUMENT SOCIETY OF AMERICA, RESEARCH TRIANGLE PARK, vol. 45, no. PART 04, 1990, pages 1899-1914, XP000172126 ISSN: 1054-0032 the whole document	1-11, 18-20, 23-29
X	US 5 367 911 A (JEWELL ANDREW D ET AL) 29 November 1994 (1994-11-29) column 11, line 58 -column 12, line 10; figure 14	1, 23

Further documents are listed in the continuation of box C.

Patent family members are listed in annex.

Special categories of cited documents :

- "A" document defining the general state of the art which is not considered to be of particular relevance
- "E" earlier document but published on or after the international filing date
- "L" document which may throw doubts on priority claim(s) or which is cited to establish the publication date of another citation or other special reason (as specified)
- "O" document referring to an oral disclosure, use, exhibition or other means
- "P" document published prior to the international filing date but later than the priority date claimed

- "T" later document published after the international filing date or priority date and not in conflict with the application but cited to understand the principle or theory underlying the invention
- "X" document of particular relevance; the claimed invention cannot be considered novel or cannot be considered to involve an inventive step when the document is taken alone
- "Y" document of particular relevance; the claimed invention cannot be considered to involve an inventive step when the document is combined with one or more other such documents, such combination being obvious to a person skilled in the art.
- "&" document member of the same patent family

Date of the actual completion of the international search

26 October 2000

Date of mailing of the international search report

03/11/2000

Name and mailing address of the ISA

European Patent Office, P.B. 5818 Patentlaan 2  
 NL - 2280 HV Rijswijk  
 Tel. (+31-70) 340-2040, Tx. 31 651 epo nl,  
 Fax: (+31-70) 340-3016

Authorized officer

Heinsius, R



INTERNATIONAL SEARCH REPORT

Intern: al Application No  
PCT/US 00/17640

C.(Continuation) DOCUMENTS CONSIDERED TO BE RELEVANT		
Category °	Citation of document, with indication, where appropriate, of the relevant passages	Relevant to claim No.
X	US 5 708 211 A (JEPSON WILLIAM PAUL ET AL) 13 January 1998 (1998-01-13) column 4, line 21 -column 8, line 42; figures 1-6 ---	1,23
A	US 5 591 922 A (SEGERAL GERARD ET AL) 7 January 1997 (1997-01-07) cited in the application column 3, line 30 -column 7, line 62; figures 1-6 -----	1-33

# INTERNATIONAL SEARCH REPORT

Information on patent family members

International Application No

PCT/US 00/17640

Patent document cited in search report	Publication date	Patent family member(s)	Publication date
US 5367911 A	29-11-1994	GB 2253907 A GB 2280267 A, B	23-09-1992 25-01-1995
US 5708211 A	13-01-1998	AU 3474197 A WO 9745716 A	05-01-1998 04-12-1997
US 5591922 A	07-01-1997	FR 2720498 A AU 699448 B AU 2032095 A BR 9502559 A CA 2150325 A EG 20705 A EP 0684458 A GB 2289766 A, B NO 952088 A	01-12-1995 03-12-1998 07-12-1995 26-12-1995 28-11-1995 30-11-1999 29-11-1995 29-11-1995 28-11-1995