

E. W. GAUBE, DEC'D.  
 I. A. GAUBE, EXECUTRIX.  
 MACHINE FOR SEALING AND CRIMPING TUBES.  
 APPLICATION FILED NOV. 19, 1913.

1,155,143.

Patented Sept. 28, 1915.

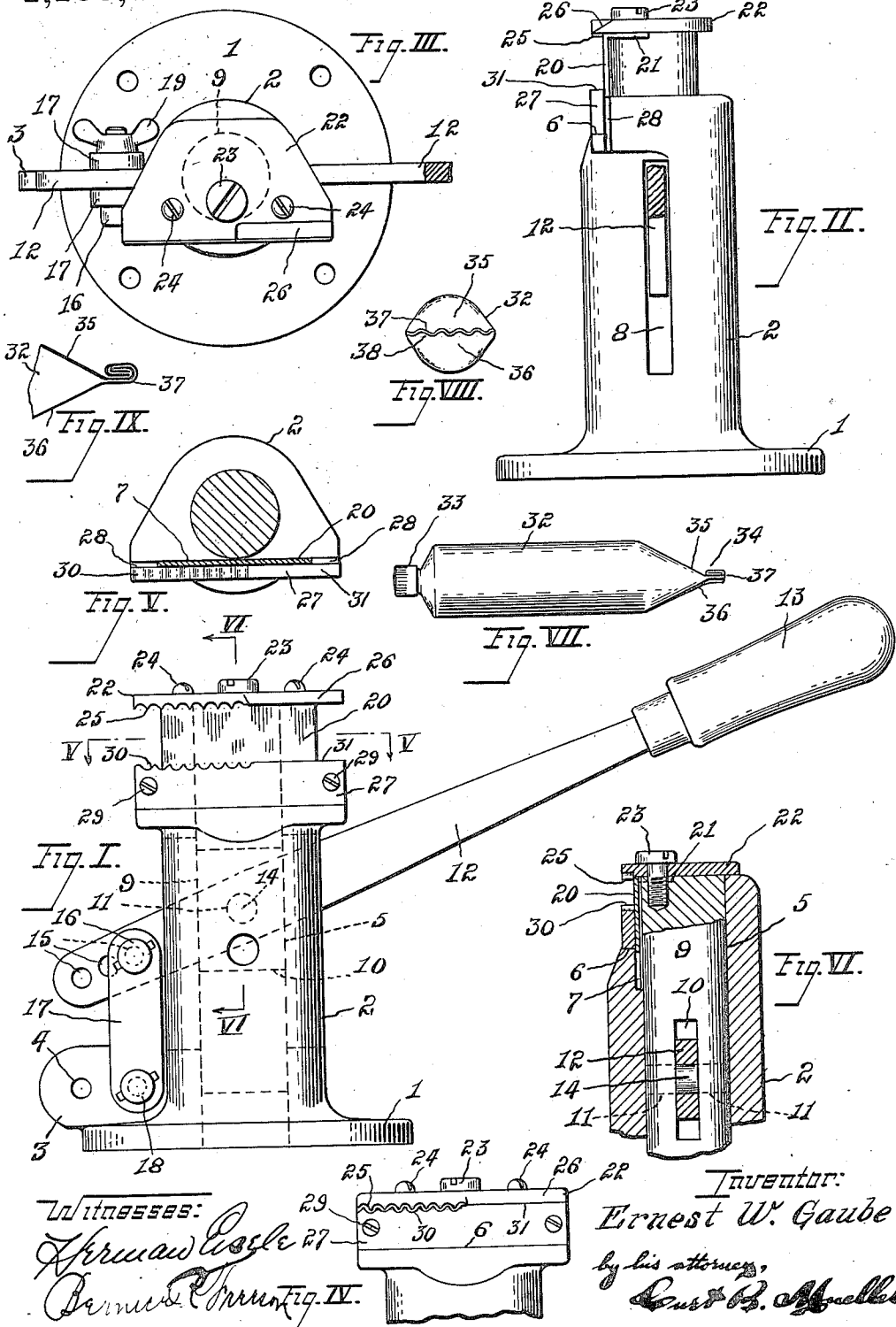

Witnesses:  
*Armand Eschle*  
*Bernice Eschle*

Inventor:  
*Ernest W. Gaube*  
 by his attorney,  
*Carl B. Mueller*

# UNITED STATES PATENT OFFICE.

ERNEST W. GAUBE, OF CLEVELAND, OHIO; IDA A. GAUBE EXECUTRIX OF SAID ERNEST W. GAUBE, DECEASED.

MACHINE FOR SEALING AND CRIMPING TUBES.

1,155,143.

Specification of Letters Patent.

Patented Sept. 28, 1915.

Application filed November 19, 1913. Serial No. 801,795.

*To all whom it may concern:*

Be it known that I, ERNEST W. GAUBE, a citizen of the United States, residing at Cleveland, in the county of Cuyahoga and State of Ohio, have invented a new and useful Improvement in Machines for Sealing and Crimping Tubes, of which the following is a specification, the principle of the invention being herein explained and the best mode in which I have contemplated applying that principle, so as to distinguish it from other inventions.

The general purpose of this invention has been sufficiently indicated by the title. Its more particular adaptation is for the closing and sealing of tubes composed of thin flexible material after the same have been filled through an open end to be thus closed.

Heretofore, in so far as I have become aware, tubes of this character have been closed rather than actually sealed. Hermetical sealing is either impracticable or else too expensive.

My invention avoids the necessity of employing any conjunctive fastening element whatsoever.

Incidental objects of my invention aside from providing a machine which will satisfactorily accomplish the desired result, are to furnish a device which is simple in operation and readily manipulated; and which will be of durable and economical manufacture.

The inventive conception is embodied in means which are hereinafter explained and variously combined in the claims, while the annexed drawing and particular description thereof together set forth in detail one certain means constituting my invention, the disclosed means however, being but one of various mechanical forms in which the principle of my invention may be applied.

Referring now to the drawing: Figure I is a front elevation of a machine embodying my invention showing an actuating member in elevation. Fig. II is a side elevation showing such actuating member in section. Fig. III is a plan of Fig. II. Fig. IV is an elevation of one detail in a different position from that seen in Figs. I and II. Fig. V is a horizontal section on line V—V of Fig. I looking downwardly. Fig. VI is a vertical section on line VI—VI of Fig. I looking in the direction of the arrows. Fig. VII represents a tube closed after the man-

ner of my invention. Fig. VIII is an end view of the inventive closure. Fig. IX is a section of the closure taken longitudinally of the tube.

The construction comprises a standard 60 having a base 1 and a pedestal 2. Projecting laterally just above the base is a boss 3 provided with a pair of horizontally extending openings each designated as 4. The pedestal 2 is hollow to form an upwardly 65 extending bore 5. An upper and what will hereinafter be regarded as the front face of the pedestal 2 is provided with a transversely extending cut-out portion of right angled cross section to present a depressed 70 flat surface 6. The pedestal 2 is furthermore provided rearwardly adjacent the surface 6 with a vertical slot 7, extending below the same as seen in Fig. VI. This slot 75 continues as a front recess upwardly beyond the surface 6. The pedestal 2 is also provided centrally with an elongated laterally extending slot 8.

Positioned for movement in the bore 5 is a plunger 9. This plunger has an axial slot 80 10 which registers with the larger slot 8 in the pedestal. The plunger 9 is furthermore provided with a pair of transversely extending openings 11 intersecting the slot 10. An actuating lever 12, having a handle 13, 85 projects through the slots 8 and 10 and is pivotally mounted on the plunger through the medium of a pin 14 extending through the opening 11. The other end of lever 12 is provided with a plurality of openings 15. 90 The lever 12, as will be apparent from an inspection of Fig. I, is fulcrumed through the medium of a pin 16 extending through one or the other of these openings (here the one nearest the handle) and a link 17 which 95 constitutes the articulating agency between the pin 16 and another pin 18 extending through one of the openings 4. Each of the pins is held in place by cooperative thumbscrews 19. In this manner as will be readily 100 understood reciprocation of the lever 12 up and down contrives to raise and lower the plunger 9, while the range to be imparted may be varied according to whatever change in the pivoting and fulcruming of 105 the lever 12 is adopted.

A right-angled guide member is carried upon the upper front of the plunger 9. This guide member comprises a downwardly extending forward portion 20 and 110

a rearwardly extending horizontal portion 21, which latter is adapted to be seated in a suitable recess in and flush with the forward upper surface of the plunger 9. The portion 20 is adapted to lie in the slot 7 and move therein. As so positioned it constitutes an abutting plate intended to limit the insertion of the tubes to be operated upon. Superimposed upon the plunger and the guide member just described is a plate 22. This plate is fixed to the plunger through the medium of a screw 23, and furthermore to opposite ends of the guide member by the smaller screws 24. The forward edge of the plate 22 projects beyond the portion 20 a distance substantially corresponding to the depth of the surface 6. It serves the function of a compressing jaw. Such projecting edge of the plate 22 has somewhat more than half of its under surface corrugated. These corrugations are aligned laterally as best seen in Fig. I. The remainder of such under surface is flat and preferably slightly elevated with respect to the line of greatest downward projection of the corrugated surface 25 for a purpose to be hereinafter explained. The surface of that portion of the plate 22 which is over the flat under surface is furthermore beveled as most clearly seen in Fig. II. The lower forward edge of such beveled surface 26, in this exemplification, coincides with the forward edge of the flat under surface and slightly to the rear of the forward surface of the corrugated portion 25. The reason for this will also be elucidated later.

A bar 27 rests upon the surface 6 and against two spacer members corresponding in thickness with the guide 20 which are interposed between the bar 27 and pedestal 2 at each end. The bar 27 and spacer members 28 are simultaneously affixed to the pedestal by means of screws 29. The upper surface of the bar 27 corresponds with the under surface of so much of the plate as projects forwardly beyond the portion 20. As such it comprises a complementary jaw having above a corrugated surface 30 and a flat surface 31, in line respectively with the opposed surfaces of the upper movable jaw. The vertical planes of the projections and concavities respectively of the corrugated portion 30 are purposely alternate with respect to the projections and concavities of the corrugated portion 25 of the plate 22. It will be comprehended therefore, that the corrugated surfaces of the jaws are capable of partially dove-tailing with each other when their flat surfaces abut. The slight elevation of the under surface of the upper movable jaw effects the desired intersection on the part of the opposed corrugated surfaces as represented in Fig. IV.

The operation of my machine is as follows: Let it be assumed that the plunger 9

of the machine has been elevated, whereby the jaws are separated as shown in Fig. I; and that a tube 32 of flexible material which has one end closed with the cap 33, has been filled through its opposite open end 33. Such open end is then inserted between the opposed flat surfaces of the jaws and against the abutting plate 20 and thereafter the lever 12 actuated in a downward direction to cause said jaws to approach each other and thereby draw two opposite sides 35 and 36 of the tube toward one another and compress the extremities of the sides 35 and 36 into close contact with each other as at 37. This portion 36 is then made to assume the relationship to the body of the tube of a partial fold by bending the tube upwardly and to the rear and over the beveled surface 26. During this manipulation the recession of the forward edge which forms the junction between the beveled surface 26 and the under surface assists in avoiding too sharp a bend. Next the jaws are again separated and such partial fold compressed to a complete fold and the tube again bent upwardly and to the rear as before. Finally the jaws are again separated and the second partial fold which has just been imparted is compressed toward and together with the first fold between the corrugated surfaces so as to become crimped as designated by the reference character 38. The degree of compression depends upon the extent of intersection of the corrugated surfaces of the jaws, practice has however demonstrated that the extent of such intersection may be comparatively slight and yet accomplish a sealed closure from which even compounds of medicinal fluid cannot leak. My invention being described with sufficient thoroughness, what I desire to secure by Letters Patent and therefore claim specifically, is:

1. A tube sealing and crimping machine comprising in combination, two members movable relative to each other, the opposed surfaces of said members being corrugated, an abutting plate transversely adjacent said surfaces, and means for effecting such relative movement.

2. A tube sealing and crimping machine comprising in combination, a standard provided with an opening and having a corrugated edge laterally adjacent said opening, a plunger mounted for movement in such opening, a member carried by and projecting therefrom said plunger, said member having a corrugated surface opposed to said edge, and means for actuating said plunger.

3. A tube sealing and crimping machine comprising in combination, a standard having an upper surface corrugated, a member mounted for movement toward and away from such surface, said member having a corrugated surface opposed to said first mentioned surface, the corrugations of said sur-

faces respectively being staggered in a direction at an angle to the direction of movement, a guided connection between said standard and member, and means for actuating said member.

4. A tube sealing and crimping machine comprising in combination, a standard, a member thereon formed on its upper surface with corrugations, a plunger movably mounted in said standard, an abutting plate carried by said plunger and adjacent said member, the direction of movement of said plunger corresponding with the direction of projection of said corrugations, a cooperating member carried by said plunger and projecting beyond said plate, said cooperating member being formed on its under surface with corrugations opposed to said first mentioned corrugations, and means for actuating said plunger.

5. A tube sealing and crimping machine comprising in combination, a pair of jaws movable relative to each other, one of said jaws having an obliquely beveled surface, said bevel merging with the inner surface of such jaw, and means for effecting said relative movement.

6. A tube sealing and crimping machine comprising in combination, a pair of jaws movable relative to each other, one of said jaws having an edge recessed with respect to

the corresponding edge of the other, said recessed edge being furthermore oblique with reference to the plane of compression, and means for effecting such relative movement.

7. A tube sealing and crimping machine comprising in combination, a plunger, a jaw projecting therefrom, means for actuating said plunger, a stationary jaw interposed in the path of movement of said first mentioned jaw, and an abutting plate carried by said plunger, said plate being recessed relative to corresponding edges of said jaws respectively and movable past the opposite side of the stationary of said jaws.

8. A tube sealing and crimping machine comprising a standard, a jaw member mounted thereon and having a portion of its upper surface corrugated, a plunger mounted for reciprocal movement and having a lateral surface in sliding contact with a lateral edge of said member a cooperating jaw member projecting from said plunger, and having a portion of its under surface corrugated, means for actuating said plunger, and means for controlling the range of movement of the latter.

Signed by me, this 15th day of Nov. 1913.

ERNEST W. GAUBE.

Attested by—

MARY COLEMAN,  
A. L. SCHLEGEL.