

(No Model.)

2 Sheets—Sheet 1.

W. SCOTT. PAPER FOLDING AND CUTTING MACHINE.

No. 562,202.

Patented June 16, 1896.

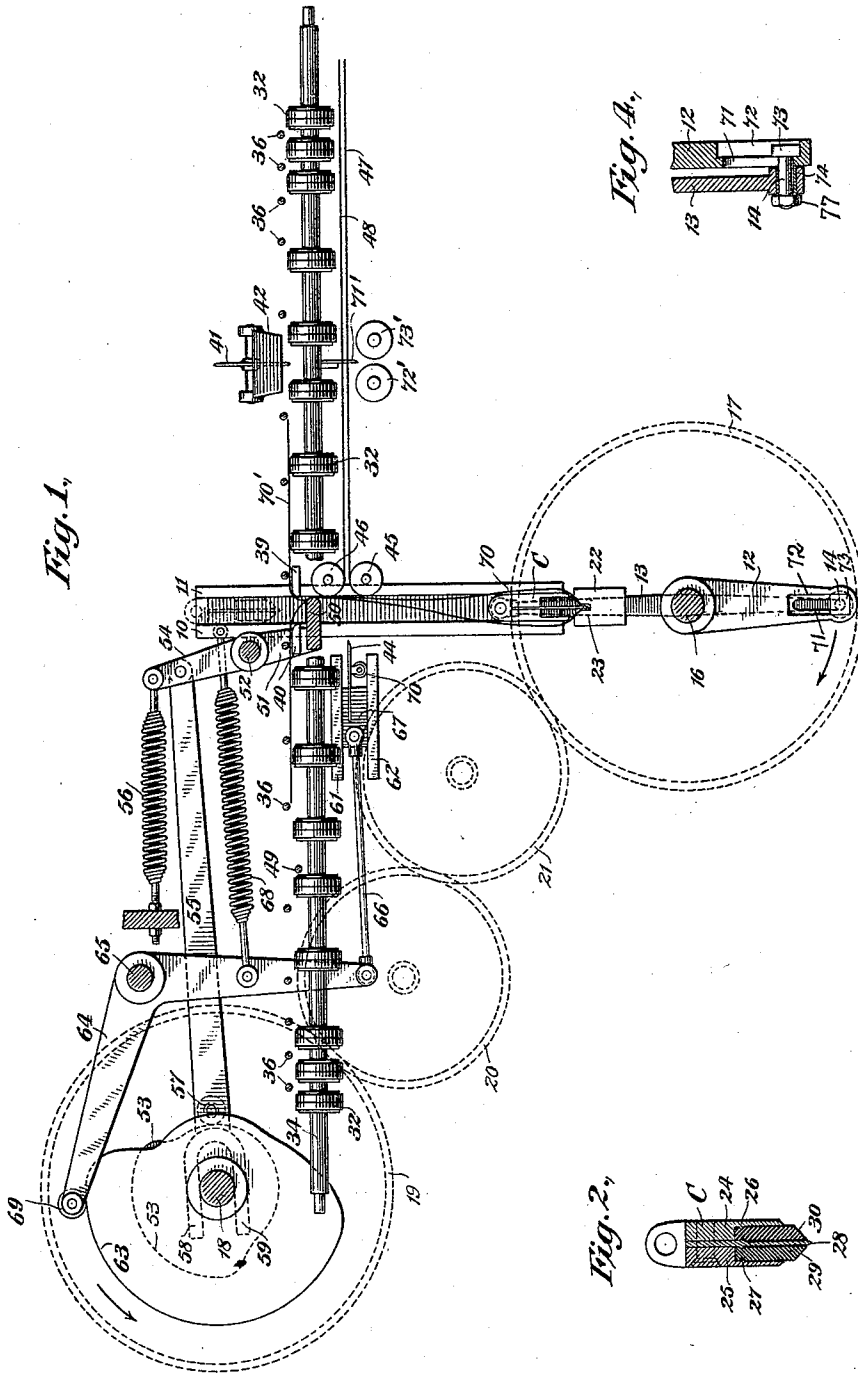

Witnesses
C. E. Ashley
H. W. L. Lynd.

Inventor
Walter Scott,
 By his Attorneys
Wilcox & Barkley

W. SCOTT.
PAPER FOLDING AND CUTTING MACHINE.

No. 562,202.

Patented June 16, 1896.

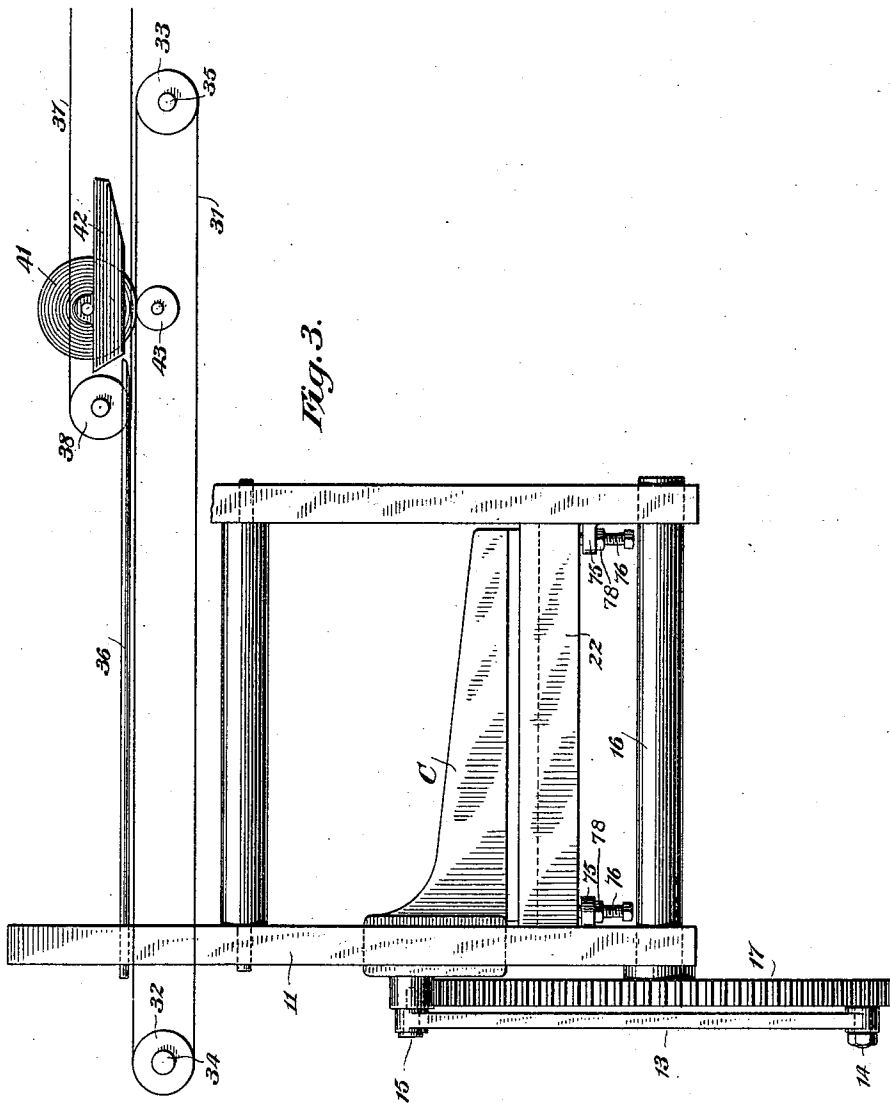

Witnesses
C. E. Ashley
J. W. Lloyd

Inventor
Walter Scott,
 By his Attorneys
Wilcox & Barkley.

UNITED STATES PATENT OFFICE.

WALTER SCOTT, OF PLAINFIELD, NEW JERSEY.

PAPER FOLDING AND CUTTING MACHINE.

SPECIFICATION forming part of Letters Patent No. 562,202, dated June 16, 1896.

Application filed June 20, 1891. Serial No. 396,899. (No model.)

To all whom it may concern:

Be it known that I, WALTER SCOTT, a citizen of the United States, and a resident of Plainfield, in the county of Union and State of New Jersey, have invented certain new and useful Improvements in Paper Folding and Cutting Machines, of which the following is a specification.

My invention relates to paper-folding machines; and it consists of the combination of devices hereinafter described, and more particularly pointed out in the claims concluding this specification.

The objects of my invention are to cut and fold and to cut, fold and paste sheets of paper into page form, whether the sheet consists of six or eight pages; and to fold four pages.

In the accompanying drawings, forming part of this specification, and showing the preferred form of my invention, Figure 1 is an end elevation of the folding mechanism from the right of Fig. 3. Fig. 2 is a detail of the folding and clamping head. Fig. 3 is a side elevation of the head and adjacent parts. Fig. 4 shows a modification I use when sheets of several widths are to be folded by the same machine.

In the drawings, I show the folding and clamping head as a cutting-head also, but the cutter-blade may be placed in other positions, as hereinafter described.

In the drawings, C indicates the folding and clamping head, which also carries the cutter by preference. The folding and clamping head is hereinafter referred to as the "head" for convenience. The head C is given a reciprocating movement in the guides 10 11 by a crank 12 and rod 13, pivotally connected to the pin 14 of crank 12 and pin 15 on the head C. The pin 14 may be on the crank 12 of shaft 16 or it may be on the gear 17 and the crank 12 omitted. The gear 17 is driven by any suitable means. I have shown a rotating shaft 18 and gears 19 20 21, connecting gear 17 and shaft 18 for driving said gear 17.

For cooperation with the head at the moment of clamping and cutting the paper, I use a preferably-adjustable clamp bar or rail 22, preferably having a Y-shaped groove 23 in its upper side. The head shown in Figs. 1 and 2 consists of the bars 24 25, which may

or may not be integral with each other having a tongue each, as 26 and 27. The cutter or knife 28 is clamped between the bars 24 25, and between the cutter and each of the bars 24 25 (which are rabbeted for this purpose) is clamped a cushion of rubber. These cushions are marked 29 30 in Fig. 2. To better hold the cushions, the cutter 28 has two ribs or tongues thereon between and opposite the tongues or ribs 26 27, above described. The cutter has a serrated edge, by preference, though this is not essential.

The printed sheets are run from any sheet-feeding device or from the printing-machine by the delivery tapes 31, passing about rollers or pulleys 32 33 on shafts 34 35, respectively, and under guide-bars 36. Tapes 37, passing about rollers 38, aid in the sheet-delivery. As the sheets reach the guides 10 and 11, or other suitable stops, the head descends and catches it along a central margin and carries it down between the two central supporting-bars 39 40, and the cushions come in contact with the sides of the Y-shaped groove in the clamp-bar 22. The cushions and the sides of the groove firmly clamp the paper adjacent the knife, and as the head still descends and compresses the cushions the knife easily cuts the sheets apart.

For the purpose of keeping the sheet flat or taut, so that the folding blade or creaser will act upon the paper along a certain margin, I sometimes employ a suitable friction device, which acts on the sheets above the blade 44. The friction device shown consists of the bar 50, borne by arms 51 of rock-shaft 52. The shaft 52 is operated by any suitable means. I have shown a cam 53 on shaft 18, an arm 54 on shaft 52, and a rod 55, pivotally connected to arm 54, the rod 55 being slotted to straddle shaft 18 and being held against the cam 53 by any suitable means, as a spring 56 fast at one end to the arm 54 and to the frame at the other. The rod 55 carries a roller against which cam 53 acts. The forks 58 59 of rod 55 straddle the shaft 18, which guides rod 55 in its motions. The bar 50 pushes the sheet to one side, so that sufficient friction is caused by it and bar 39 to keep the sheet taut. The bar 50 moves into the position shown after the head C passes down below it, and moves

to the left out of the way of head C before the latter reaches it in the upward movement of the head.

Where it is desired to paste the inside sheet to the outer one, paste is applied to the latter on another central margin on the top thereof by a wheel 41, taking paste from a fountain 42. A roller 43 below the sheets supports them against the wheel 41.

After the knife 28 has severed the sheet into the outer and inner sheets, the movable blade 44 pushes the sheets between the rollers or pulleys 45 46, the blade striking the central margin of the sheets. Thus in the case of an eight-page paper the blade acts on the central margin of both the inner and the outer four-page sheets, while in the case of a six-page paper it acts on the central margin of the outer four-page sheet and a margin of the inner two-page sheet. Tapes 47, passing around roller 45, and tapes 48, passing about roller 46, convey the sheets to a folder or other delivery. I have not shown the tapes 47 and 48 *in extenso*, since their arrangement and operation may be of well-known forms. The operation just described applies rather to an eight-page paper; that is, the head C strikes the central margin of the sheet and severs it, as described, and the blade or creaser 44 strikes the central margin of the two sheets thus formed, and the sheet as folded by the rollers 45 46 is on page form. In the case described so far the sheet extends the full length of the rollers 32 in Fig. 1.

In case of a six-page sheet, the sheet extends from the right-hand roller 32 in Fig. 1 to the bar 49 on which the sheet rests. That is, there are three pages on each side of the sheet, and the folder C strikes one of the central margins (the paste-wheel 41 supplying paste to the other central margin) and folds it in the manner described above, the bar 50 operating as above described. That part of the sheet that rests on the bar 49 may have a wide side margin, so that as that margin comes against the central margin of the other part of the original sheet and is folded in by folder 44, it will be doubled over; that is, along the line of the fold there will be two thicknesses of paper just as is the case in the eight-page paper described above.

I sometimes use a roller or rollers 70 on the under side of folding-blade 44 to aid in starting the folded sheets between rollers 45 46. The folding-blade moves over until roller 70 bears against roller 45 and assists that roller in feeding the sheets to the tapes 47 48 as described.

The folding blade or creaser 44 is shown as a reciprocating part, but it is obvious that it may have an oscillating or a rotary motion if desired.

Folding-blade 44 is directed by stationary guides 61 62, and is operated by a cam 63 on shaft 18, lever 64, fulcrumed at 65 in the framework, and rod 66, pivotally connected to lever 64 and slide-head 67, which carries the folding-

blade 44. A spring 68, connected to the lever 64 and to the framework, holds the roller 69 on lever 64 against the cam 63.

Closed cams may be substituted for cams 53 and 63, if desired.

The pulleys 32 are supported in any suitable manner. I have shown a shaft 34 for this purpose, which is journaled in the framework of the machine.

If it is desired to fold a four-page paper, a folding-blade 71' and rollers 72' 73' may be used, the blade acting along the central margin of the sheet. The blade is shown as having moved down from its highest position. The blade may be operated by any suitable mechanism.

The use of a paster-roller, as 41, is not essential, but such a device is used sometimes by me.

I do not limit myself to the precise arrangement and location of parts shown in the drawings, as I am aware that many changes may be made without departing from my invention. Thus the rollers 45 46 and the blade 44 may be placed at a lower level than that shown, and the bars 39 40 be dispensed with. For instance, the cutter-blade 28 and cushions 29 30 may be placed on the bar 22 instead of the head C, and the head C grooved opposite the cutter. Again the rubber cushions may be replaced (in the head C or on bar 22) by movable bars supported by springs, (thus forming cushions,) the cutter being fixed in the head or bar. The cutter may be on the bar 22 while the cushions may be on the head C. The friction-bar 50 may reciprocate if desired. Any suitable mechanism may be used to reciprocate it. Other changes may be made, as in the mechanisms for operating the folder 44 and friction-bar 50, or in these parts themselves, without departing from my invention.

I have, for clearness, shown the sheet in full lines, as being loose about the head C. In practice it hugs the head closely and is taut back to the bars 39 and 50.

The pin 14 of crank 12 may be adjustable radially of the crank for the purpose of giving less throw to the head C. This is desirable in case of the use of sheets narrower than the one shown. The female cutter-bar or clamp-bar 22 would then be adjustable also.

The pin 14 may be adjusted in any suitable way. As one way of so adjusting it, I have shown a slot 71, extending partly through the crank 12, a wider and longer slot 72 behind slot 71 and connecting with slot 71, a square head 73 on pin 14, the head resting in and being held by the side walls of slot 72, a ferrule 74 on pin 14, and a nut 77 to clamp the parts in place. The ferrule 74 is slightly longer than the thickness of rod 13. Hence there is no binding of the latter when nut 77 is screwed on. The slot 72 being longer and wider than slot 71 and the latter being centrally placed of slot 72 there is a step extending around slot 71, against which head

73 rests. A simple slot through crank 12 with pin 14 passing through it, and having head 73 (or a nut) nut 77, and ferrule 74 may replace the devices shown; or other means of adjusting crank-pin 14 may be used if desired.

The female cutter bar or clamp 22 is shown as being adjustable by means of nuts 75 on the framework, and screw-bolts 76, passing therethrough and which support bar 22, with which they may have a swivel connection, or the bar may simply rest on them and be held in place by suitable guides in the framework. Clamp-nuts on bolts 76 may be used. Such nuts are shown and are marked 78.

The various moving parts are supported by any suitable framework, as will be understood. I have not deemed it necessary to show such framework, as its structure may be of any form desired. Rods 36 are supported at one end in the framework, as is rod 49.

There may be several rods 49, to accommodate sheets of various widths, or rod 49 may be moved from place to place for the same purpose.

The sheets may be fed by hand to the proper position for the head C to act on them, or tapes other than the delivery-tapes of a printing-machine may be used to feed them.

While I have shown a roller and fountain for supplying paste to the sheets, it must be understood that my invention is not limited to such a device. Other means of supplying paste to the sheet may be used without departing from my invention in this respect.

It will be noted that the paste device shown is placed so that the sheets are clear of it before the head C begins to draw them at right angles to their original direction.

The head C is guided at one end only, to wit, the end that works in guides 10 and 11. The working part of the head is therefore of a bracket or cantaliver form, such as shown in Fig. 3. For some purposes the head C may be supported at each end instead of being bracket-shaped.

While I have shown a crank and rod for reciprocating the head C, I do not limit myself to such means, since the head may be moved by any suitable mechanism or means.

By adjusting the pin 14, or by adjusting the screws 76, or both, the relative positions of the head and clamping-bar can be nicely regulated.

I do not confine myself to the precise secondary folding apparatus shown (that is, to rollers 45 46 and blade 44) since it may be replaced by other forms of folding mechanism without departing from this invention.

Having thus fully described my invention, what I claim is—

1. In a folding-machine, the combination with sheet-feeding appliances, of a reciprocating folding and clamping head, mechanism moving it, a cutter-blade, and a clamp-bar

which cooperates with the said head, substantially as and for the purposes described.

2. In a folding-machine, the combination with sheet-feeding appliances, of a reciprocating folding and clamping head, mechanism moving it, cushions, a cutter-blade, and a clamp-bar which cooperates with the head, substantially as and for the purposes described.

3. In a folding-machine, the combination with sheet-feeding appliances, of a reciprocating folding and clamping head carrying a cutter-blade and cushions, mechanism moving said head, and a grooved clamp-bar which cooperates with the cushioned head, substantially as and for the purposes described.

4. In a folding-machine, the combination with sheet-feeding appliances, of a reciprocating folding and clamping head, mechanism reciprocating it, guide-bars for the sheets between which the head passes, a cutter-blade, and a clamp-bar which cooperates with said head, substantially as and for the purposes described.

5. In a folding-machine, the combination with sheet-feeding appliances, of a reciprocating folding and clamping head, mechanism reciprocating it, guide-bars for the sheets between which the head passes, cushions, a cutter-blade, and a clamp-bar which cooperates with said head, substantially as and for the purposes described.

6. In a folding-machine, the combination with sheet-feeding appliances, of a reciprocating folding and clamping head carrying a cutter-blade and cushions, mechanism reciprocating said head, guide-bars for the sheets between which said head passes, and a grooved clamp-bar which cooperates with the cushioned head, substantially as and for the purposes described.

7. In a folding-machine, the combination with sheet-feeding appliances, of a reciprocating folding and clamping head, mechanism moving it, a cutter-blade, a clamp-bar which cooperates with the said head, a movable sheet-retarding or friction bar, a folding-blade, folding devices, cooperating with the said blade, substantially as and for the purposes described.

8. In a folding-machine, the combination with sheet-feeding appliances, of a reciprocating folding and clamping head, mechanism moving it, guide-bars for the sheets between which the head passes, a cutter-blade, a clamp-bar which cooperates with said head, a movable sheet-retarding or friction bar, a folding-blade, folding devices, cooperating with the said blade substantially as and for the purposes described.

9. In a folding-machine, the combination with sheet-feeding appliances, of a reciprocating folding and clamping head, mechanism moving it, cushions, a cutter-blade, a clamp-bar which cooperates with the said head, a movable sheet-retarding or friction bar, a

folding-blade, folding devices, cooperating with the said blade, substantially as and for the purposes described.

10. In a folding-machine, the combination with sheet-feeding appliances, of a reciprocating folding and clamping head, mechanism moving it, guide-bars between which it passes and which support the sheets, cushions, a cutter-blade, a clamp-bar which operates with said head, a movable sheet-retaining or friction bar, a folding-blade, folding devices, cooperating with the said blade, substantially as and for the purposes described.

11. In a folding-machine, the combination with sheet-feeding appliances, a paste device applying paste to said sheets as they are carried forward by said appliances, a folding, clamping and cutting mechanism, substantially as described, folding, clamping and severing said sheets to form two sheets, a frictional retaining device to keep said sheets taut, and a secondary folding apparatus for folding said two sheets along the line of paste, substantially as described.

12. In a folding-machine, the combination with two sheet-supporting bars and a reciprocating folding and cutting head, of appliances feeding the sheets parallel to and between the head and bars, a stationary clamping-bar with which the head coacts to sever the sheets, and a secondary folding apparatus for folding the two sheets into one product whereby the sheets are folded cut and folded in directions parallel with their line of travel in entering the machine, substantially as described.

13. In a folding-machine, the combination with appliances capable of feeding sheets of different widths, two parallel bars, of a reciprocating folding-head passing between the said bars, a cutter, a stationary bar with which the head coacts to sever the sheets, a creaser and folding devices to fold said sheets together, either two full sheets or one and one-half sheets after cutting, substantially as described.

14. In a folding-machine, the combination of sheet-feeding appliances, a reciprocating folding and clamping head, a cutter-blade, a clamping-bar with which the head coacts during the severing of a sheet, a friction device to control the sheets as they are folded, folding devices, and a creasing-blade, whereby sheets are folded and cut along one margin and folded along another, substantially as described.

15. In a folding-machine, the combination of sheet-feeding appliances, a reciprocating folding and cutting head, a female clamping-bar which coacts with said head as the sheets are cut, a friction device to control the sheets as they are folded, folding devices and a folding blade or creaser, whereby sheets are folded, cut and folded, substantially as described.

16. In a folding-machine, the combination of two sheet-supporting bars, a reciprocating folding and cutting head, appliances for feeding the sheets between said bars and said head, a stationary clamping-bar coacting with the head to sever the sheets, a friction device to control loose ends of the sheets, folding devices and a creaser whereby sheets are folded, cut, and folded, substantially as described.

17. In a folding-machine, the combination of sheet-feeding appliances, a reciprocating folding and clamping head, a cutter-blade, two parallel bars between which the head passes, a stationary bar coacting with the head to sever the sheets, a friction device to control loose ends of the sheets, folding devices and a creaser, whereby sheets are folded, cut, and folded, as described.

18. The combination of a reciprocating head having a cutter-blade and a beveled cushion at each side of the blade, with a stationary bar having a Y-shaped groove for coaction with the cushions and blade, substantially as described.

19. A cutting-head composed of two rabbeted bars, a cutter-blade clamped between the bars, and a cushion placed between each bar and the blade, in the rabbeted portion of the bar in combination with a slotted or grooved bar, substantially as described.

20. A cutting-head composed of two rabbeted bars, each having a tongue or rib on the side of the rabbeted portion, a cutter-blade clamped between said bars and rubber cushions in the spaces between the blade and the bars, each held by a rib and the clamping action of the bars in combination with a slotted bar, substantially as described.

21. A cutting-head composed of two rabbeted bars each having a tongue or rib on the side of the rabbeted portion, a cutter-blade clamped between the bars and having ribs thereon, and rubber cushions in the spaces between the blade and the bars, each cushion held by a pair of ribs and the clamping action of a bar and the blade in combination with a slotted bar, substantially as described.

22. In a folding-machine, the combination of sheet-feeding appliances, a reciprocating folding and clamping head, driving means, adjustable connections between said means and said head whereby the stroke of the latter can be varied, a cutter-blade, an adjustable clamping-bar which coacts with said head to sever the sheets, and means for adjusting the said bar, substantially as described.

Signed at New York, in the county of New York and State of New York, this 11th day of August, A. D. 1891.

WALTER SCOTT.

Witnesses:

R. W. BARKLEY,
PAUL WILCOX.