



(19) **United States**

(12) **Patent Application Publication**
Lieu

(10) **Pub. No.: US 2003/0179182 A1**

(43) **Pub. Date: Sep. 25, 2003**

(54) **ARTICLE COMPRISING AN ADAPTABLE INPUT DEVICE**

Publication Classification

(76) Inventor: **Winston Hong Lieu, Holmdel, NJ (US)**

(51) **Int. Cl.⁷ G09G 5/08**

(52) **U.S. Cl. 345/158**

Correspondence Address:
DEMONT & BREYER, LLC
SUITE 250
100 COMMONS WAY
HOLMDEL, NJ 07733 (US)

(57) **ABSTRACT**

(21) Appl. No.: **10/371,923**

(22) Filed: **Feb. 21, 2003**

Related U.S. Application Data

(60) Provisional application No. 60/359,199, filed on Feb. 21, 2002. Provisional application No. 60/359,200, filed on Feb. 21, 2002.

A host device having an adaptable input device. An aspect of the operation of the adaptable input device changes as a function of a state of the portable terminal. In some embodiments, the aspect of operation that changes is the functionality of the adaptable input device. In some further embodiments, the aspect of operation that changes is the directionality of the input device. For example, when the adaptable input device functions as a pointing device, the aspect of operation that changes is the response of the cursor and/or insertion point to movement of the pointing device.

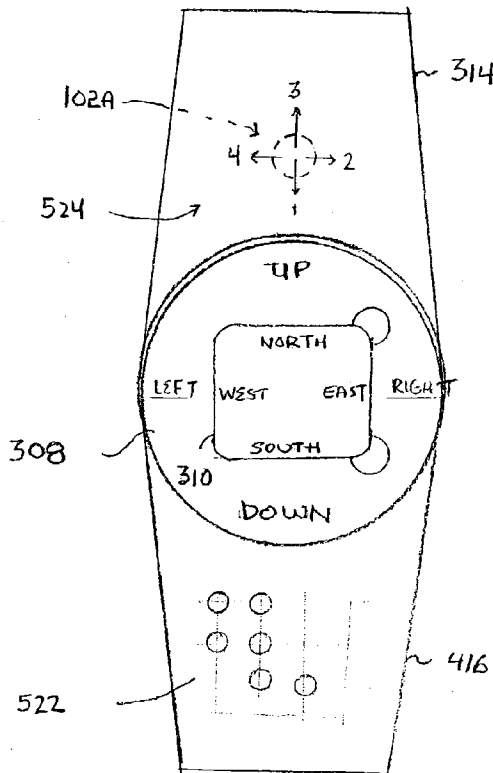

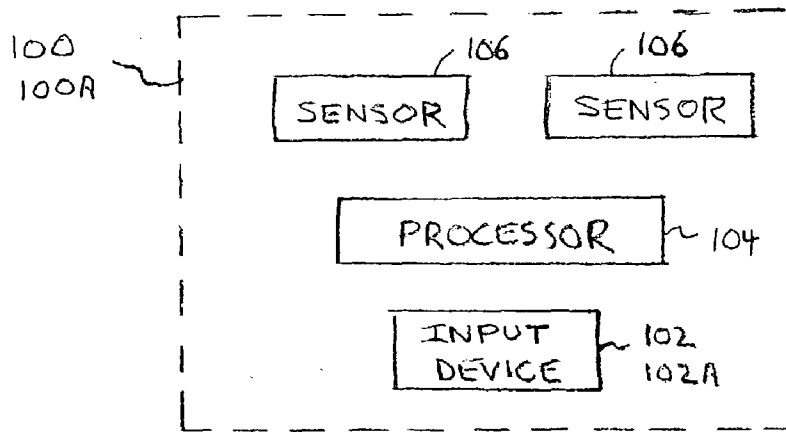

FIG. 1

200

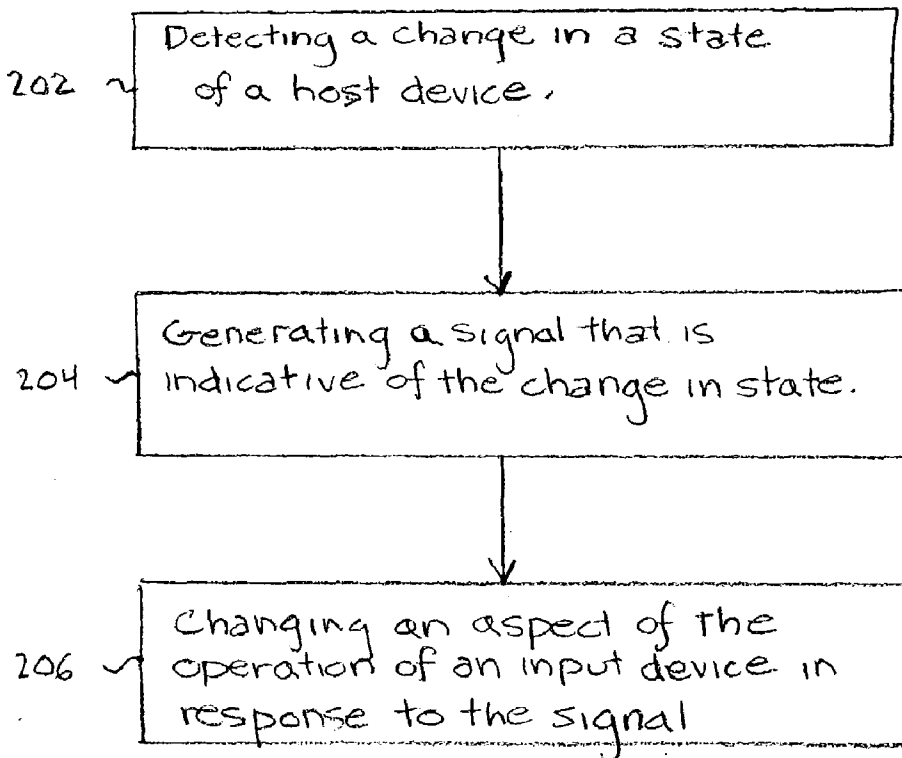

FIG. 2

FIG. 3

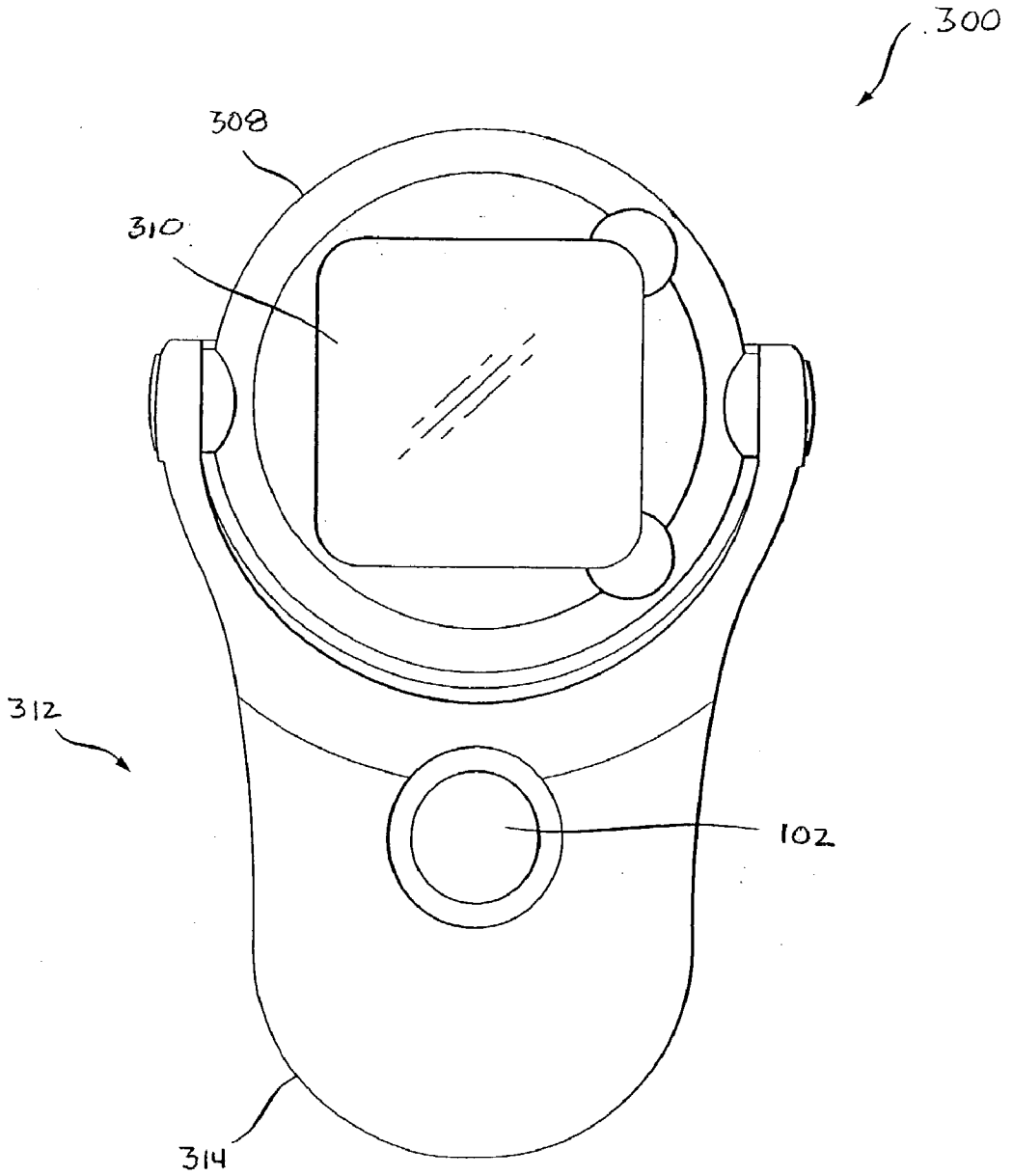

FIG. 4

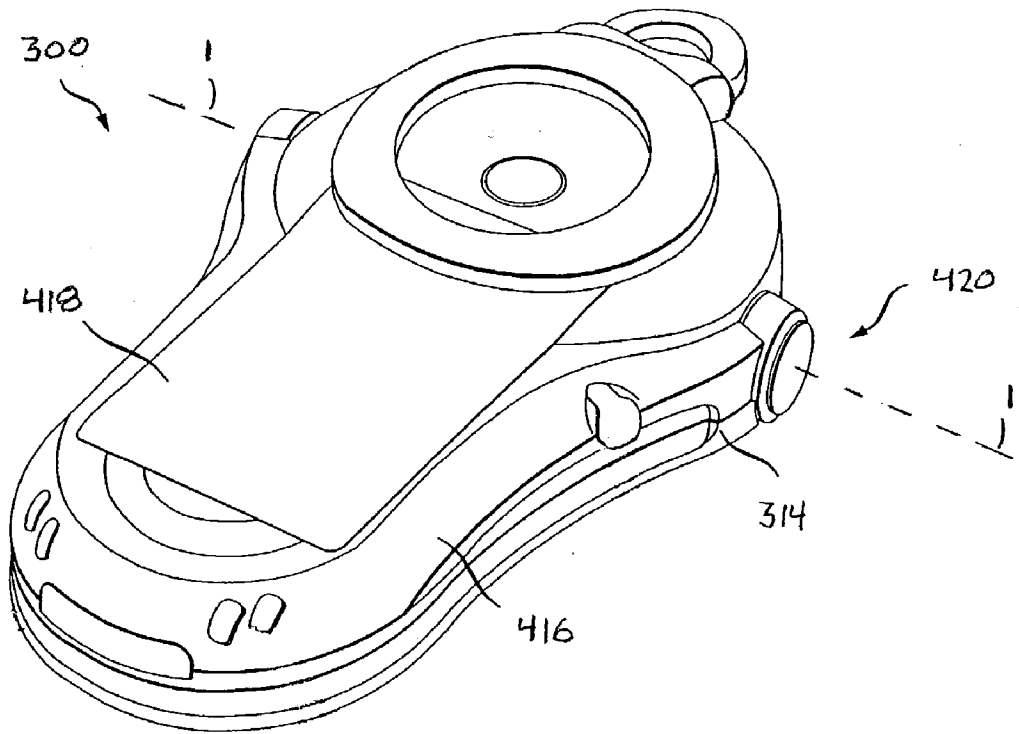

FIG. 5

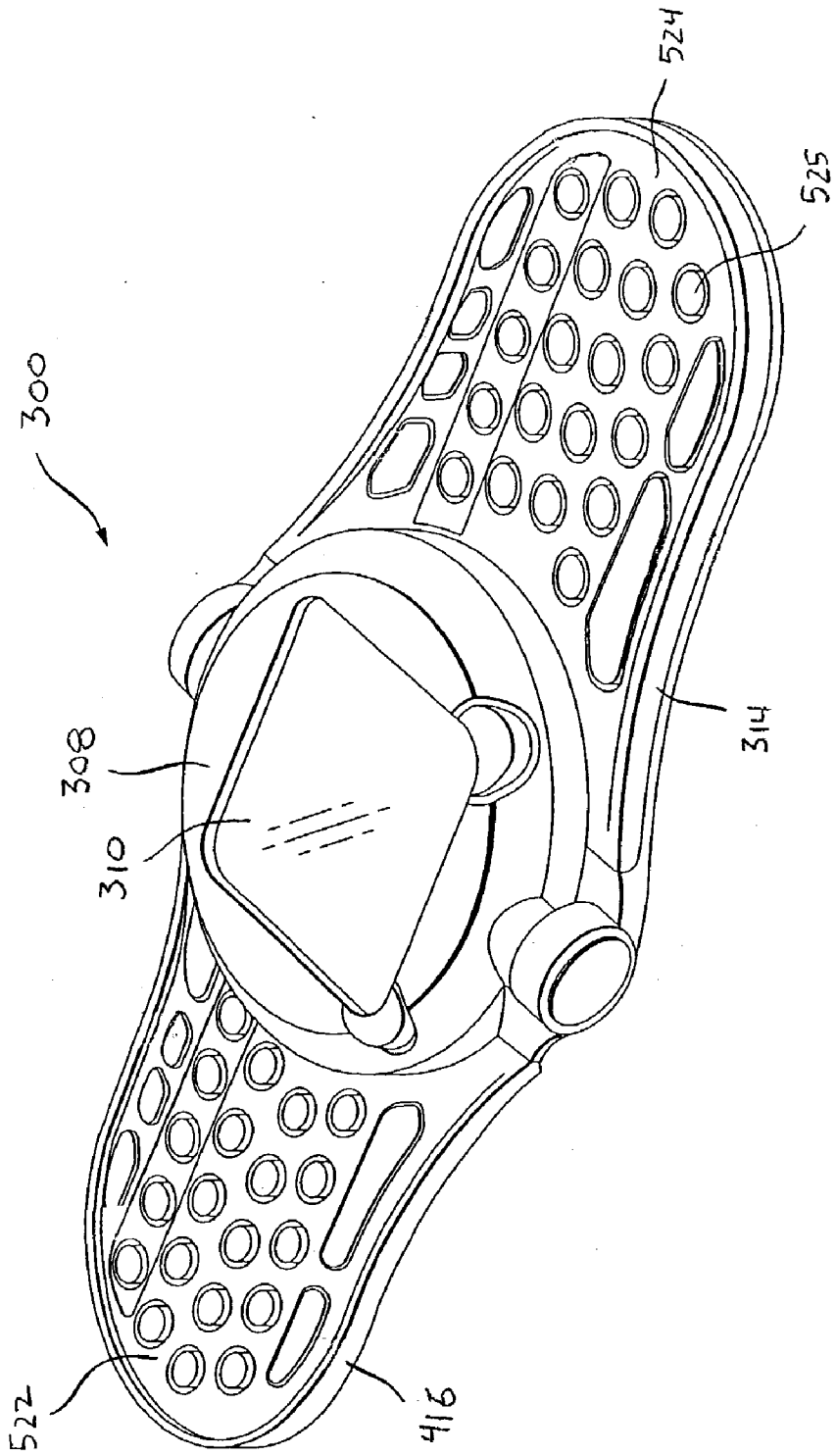

FIG. 6A

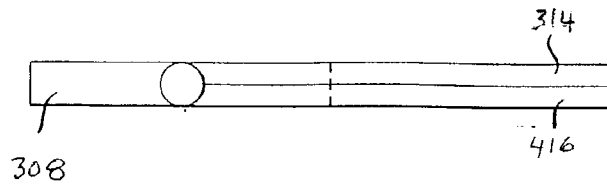

FIG. 6B

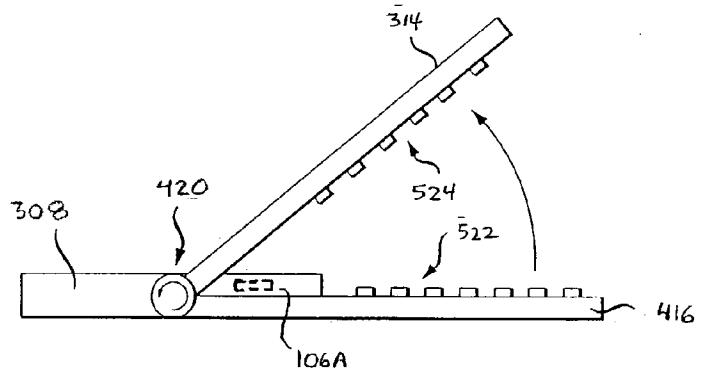

FIG. 6C

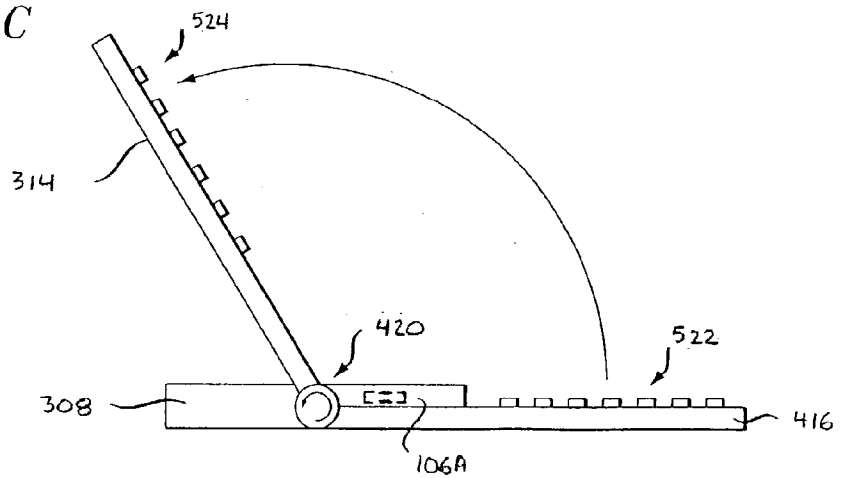

FIG. 6D

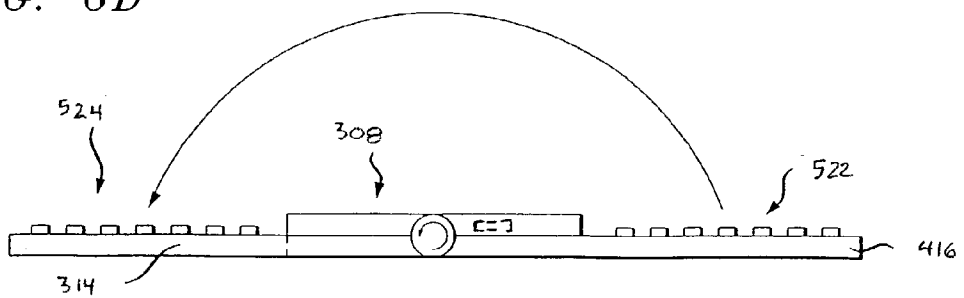
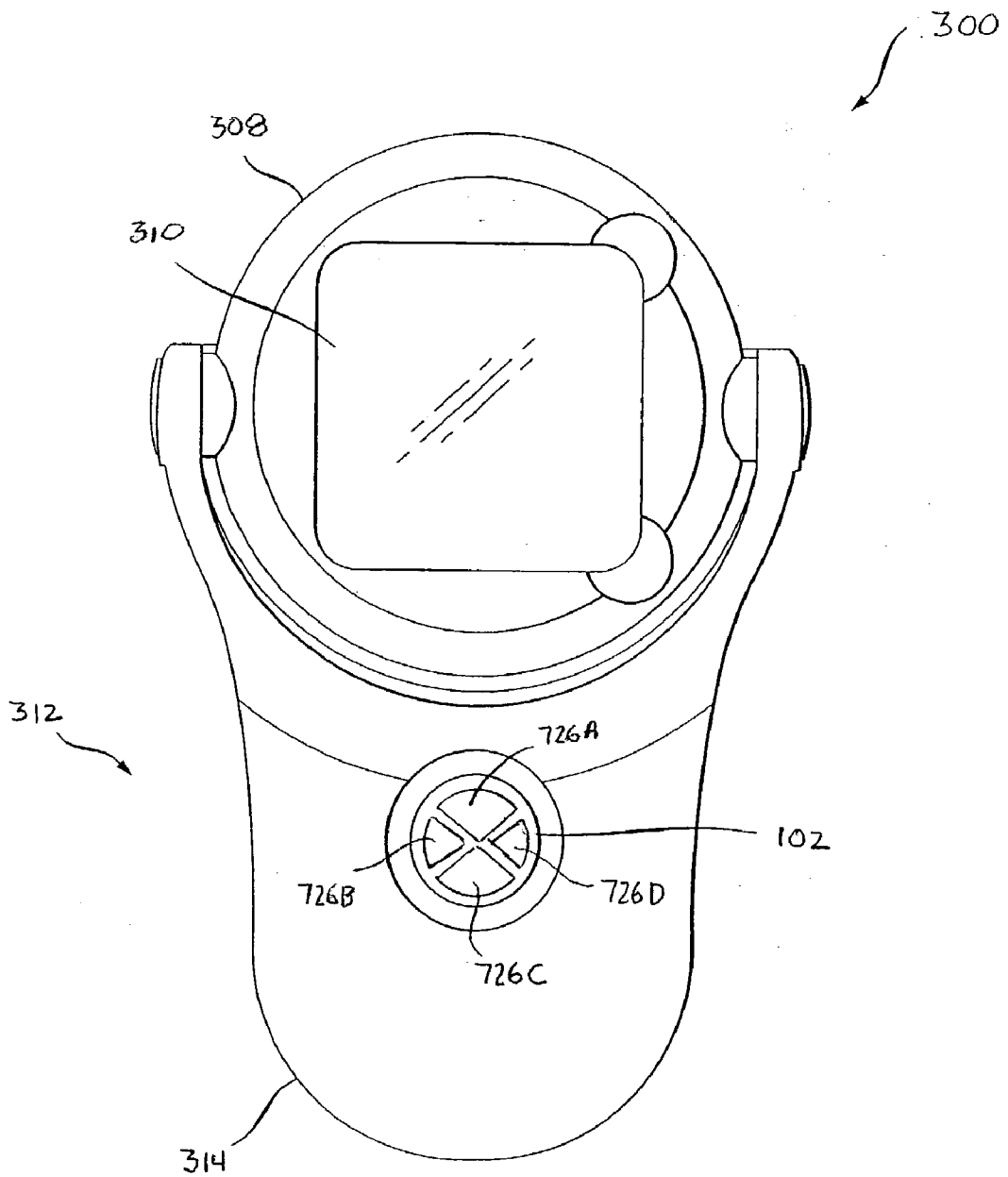

FIG. 7



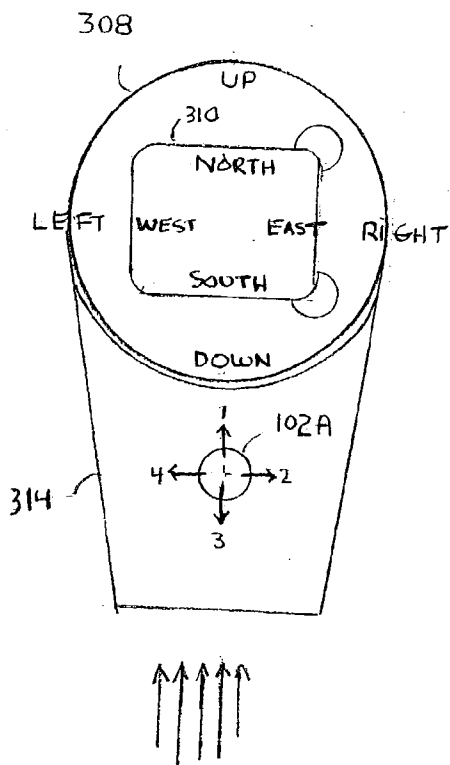

FIG. 8

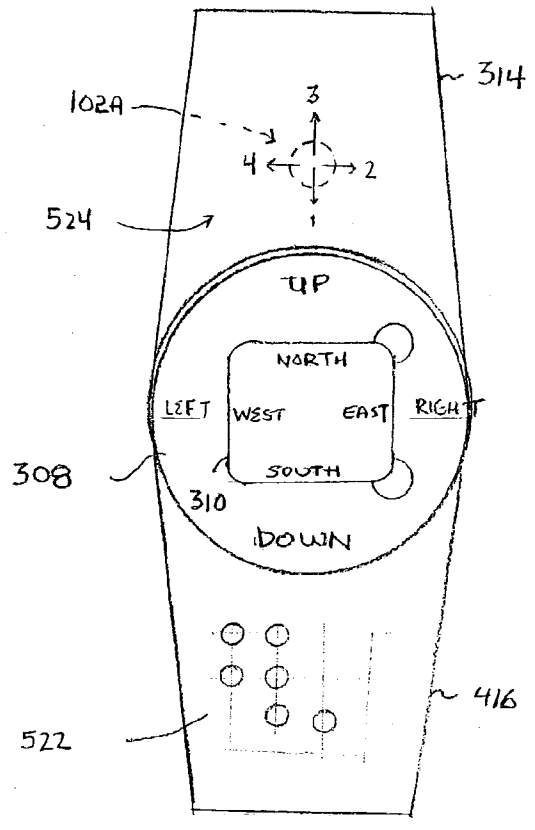

FIG. 9

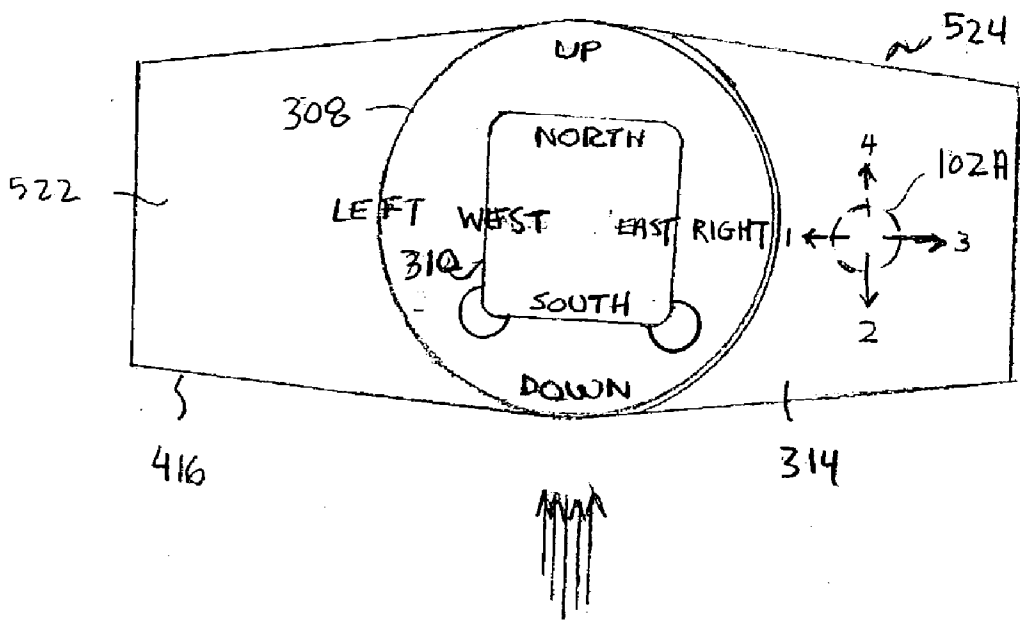
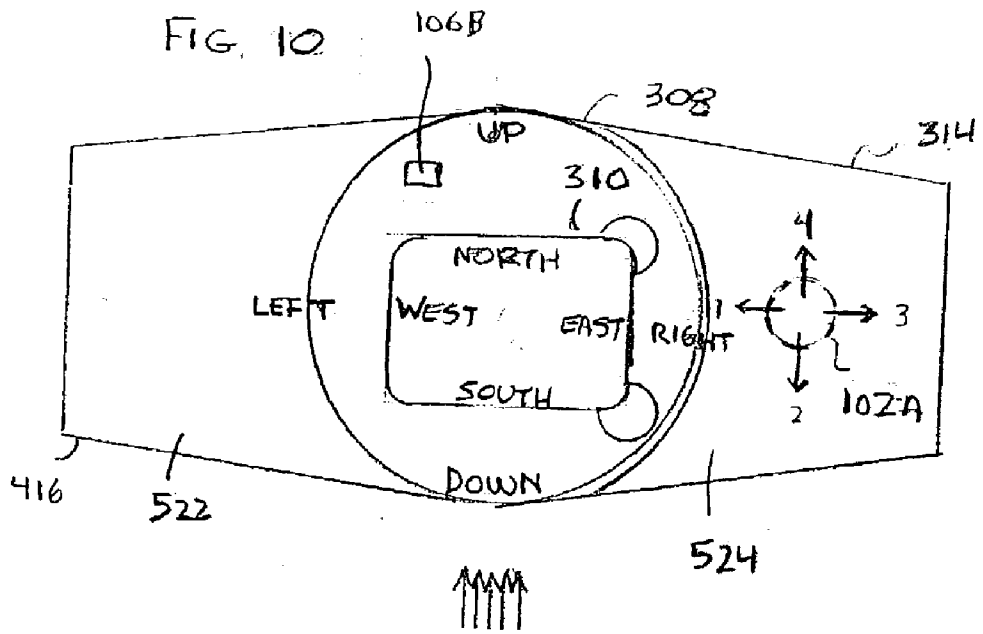

FIG. 11

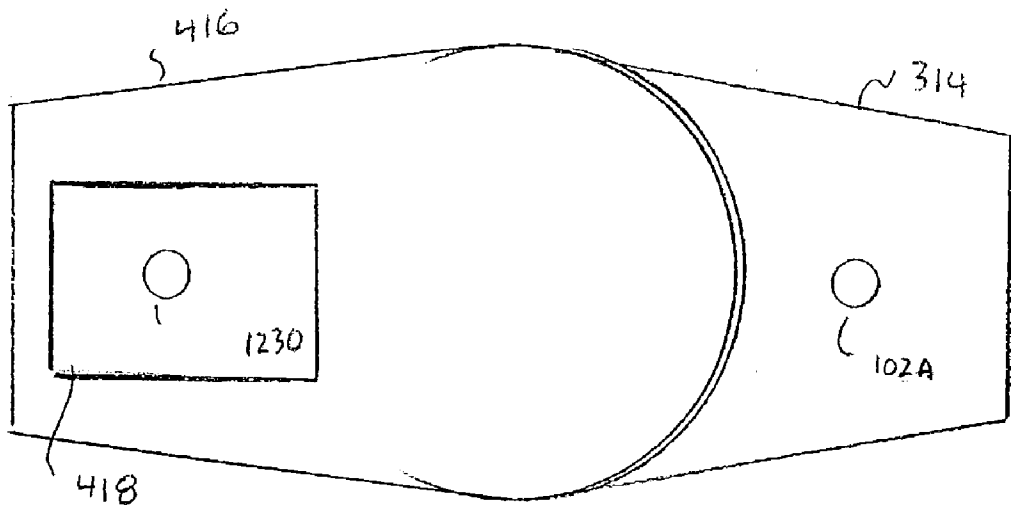

FIG. 12

ARTICLE COMPRISING AN ADAPTABLE INPUT DEVICE

STATEMENT OF RELATED CASES

[0001] This case claims priority of U.S. Provisional Patent Applications 60/359,199 and 60/359,200, both filed on Feb. 21, 2002.

FIELD OF THE INVENTION

[0002] The present invention relates to a graphical user interface, and more particularly to an input device.

BACKGROUND OF THE INVENTION

[0003] A graphical user interface (“GUI”) enables a user to interface with a computer program. In conjunction with the graphical capabilities of the computer, the GUI uses menus and graphical symbols called “icons” to carry out commands, open files and select options. A well-designed GUI frees a user from learning complex command languages, as is required when using a character-based interface (e.g., DOS, etc.).

[0004] The graphical symbols of the GUI are organized on a display screen using principles that are similar to those that are used for arranging the working surface of a desk. Hence, this system of organization is called a “desktop.”

[0005] One way by which a user interacts with the desktop is to use a pointing device. A variety of different kinds of pointing devices are available. Examples of pointing devices include the “mouse,” “trackball,” “trackpad,” “lightpen,” “joystick,” and “stylus.”

[0006] The pointing device, which is a part of the GUI, enables a user to move about or “navigate” the desktop to accomplish specific tasks. One task, for example, is to move items (e.g., files, etc.) between various locations (e.g., folders, directories, etc.). The items are moved with the pointing device using physical “gestures,” such as by “pointing,” “clicking,” and “dragging.” Movements or gestures of the pointing device are echoed on the desktop by movements of a cursor or “pointer,” which usually appears in the display screen as a small arrow (and/or by movement of an insertion point—which can be distinct from the cursor).

[0007] The trend in consumer electronics toward miniaturization and ever-increasing functionality presents certain challenges in the design of GUIs, and pointing devices in particular.

SUMMARY OF THE INVENTION

[0008] The illustrative embodiment of the present invention is an adaptable input device for use in conjunction with a host device. In the illustrative embodiment, the host device is a combined PDA/wireless terminal (hereinafter a “portable terminal”).

[0009] In accordance with the illustrative embodiment, an aspect of the operation of the adaptable input device changes as a function of a state of the portable terminal. As used herein, the term “state” refers to a physical attribute of the portable terminal (or other host device), such as a changeable physical configuration or spatial orientation of the host device. The term explicitly excludes changes in “soft” aspects of the portable terminal, such as a change in pro-

gramming, or a change in a menu that appears in a display screen of the portable terminal.

[0010] In some variations, the aspect of operation that changes is the functionality of the adaptable input device. For example, in some embodiments, the functionality changes from being able to access telecommunications capabilities (e.g., accessing menus to initiate phone calls, etc.) to operating as a pointing device. In some further embodiments, the aspect of operation that changes is the directionality of the input device. For example, when the adaptable input device functions as a pointing device, the aspect of operation that changes is the response of the cursor and/or insertion point to movement of the pointing device.

[0011] These and other variations of the illustrative embodiments of the present invention are described in further detail in the Detailed Description.

BRIEF DESCRIPTION OF THE DRAWINGS

[0012] FIG. 1 depicts a schematic of an adaptable input device in accordance with the illustrative embodiment of the present invention.

[0013] FIG. 2 depicts a method for changing the operation of an input device in response to a change in state of a host device.

[0014] FIG. 3 depicts a plan view of a portable terminal, wherein the portable terminal is closed.

[0015] FIG. 4 depicts a perspective, back view of the portable terminal of FIG. 3.

[0016] FIG. 5 depicts a perspective view of the portable terminal of FIG. 3, wherein the portable terminal is open.

[0017] FIGS. 6A-6D depict the cover of a portable terminal in accordance with the illustrative embodiment being rotated from a fully-closed position (FIG. 6A) to a fully-open position (FIG. 6D).

[0018] FIG. 7 depicts a variation of the portable terminal of FIG. 3, wherein the portable terminal includes the adaptable input device of FIG. 1.

[0019] FIG. 8 depicts a variation of the portable terminal of FIG. 3, wherein the portable terminal includes an adaptable pointing device, and wherein the portable terminal is closed and is in a vertical orientation.

[0020] FIG. 9 depicts the portable terminal of FIG. 8, wherein the portable terminal is open and is in a vertical orientation.

[0021] FIG. 10 depicts the portable terminal of FIG. 8, wherein the portable terminal is open and is in a horizontal orientation, and wherein the display of the portable terminal is physically rotated.

[0022] FIG. 11 depicts the portable terminal of FIG. 8, wherein the portable terminal is open and is in a horizontal orientation, and wherein images in the display screen are electronically rotated.

[0023] FIG. 12 depicts a variation of the portable terminals shown in FIGS. 8-11, wherein the portable terminal includes, in addition to the pointing device that is disposed on the cover, a second pointing device that is disposed on the base.

DETAILED DESCRIPTION

[0024] In the illustrative embodiment of the invention, a host device incorporates an adaptable input device. In this context, the term “adaptable” means that one or more aspects of the operation of the input device can change as a function of a state of the host device.

[0025] As used herein, the term “aspect(s) of the operation” means one or more characteristic of the way in which the input device works. Such characteristics include, without limitation, the functionality of the input device and the response of other elements of the host device (e.g., a cursor, etc.) to actuation of the input device.

[0026] The adaptable input device described herein is most readily described with reference to a particular host device. In the illustrative embodiment, the host device is a portable terminal. It is to be understood, however, that in other embodiments, the adaptable input device is used in conjunction with other types of host devices, such as media players (e.g., gaming devices, MP3 players, etc.), dedicated PDAs, dedicated wireless terminals, location-determining devices, etc.

[0027] This Detailed Description begins with disclosure pertaining to the adaptable input device itself, without regard to its use in conjunction with any particular host device. This is followed by a description of the illustrative host device—portable terminal 300. The description of portable terminal 300 is included to provide context for the use of the adaptable input device.

[0028] FIG. 1 depicts adaptable input device 100. The adaptable input device includes input device 102, processor 104, and, optionally, one or more sensors 106.

[0029] In the illustrative embodiment, input device 102 is a pointing device 102A. A pointing device is a device that is capable of moving an on-screen cursor or insertion point or both to a desired location on a display screen, in known fashion. The pointing device can have any one of a number of well-known configurations, such as, without limitation, a joystick, plural buttons, etc. In some embodiments, pointing device 102A possesses additional functionality, such as the ability to “click on” an icon, etc.

[0030] Processor 104 is capable of mapping movements of the on-screen cursor and/or insertion point to movements of pointing device 102A, in known fashion. As used herein, the term “processor” means a single integrated circuit (“IC”), or a plurality of ICs or other components that are connected or otherwise function cooperatively, such as microprocessors, including programmed general purpose microprocessors or special purpose microprocessors, digital signal processors, memory (e.g., RAM, ROM, etc.) and the like.

[0031] Sensor(s) 106 are capable of detecting changes in a state (previously defined) of a host device. The purpose for detecting changes in the state of the host device is to trigger changes in the operation of adaptable input device 100 (e.g., change in functionality, change in cursor/insertion point response, etc.). For example, in various embodiments, the sensor(s) can detect, without limitation:

[0032] whether a housing of the host device is open or closed; or

[0033] whether the host device has a vertical or horizontal orientation; or

[0034] whether a display screen has been rotated; or

[0035] two or more of the aforementioned conditions.

[0036] Consistent with the definition of the term “state” provided above, changes in soft aspects (e.g., a change in a menu, etc., that is displayed in a display screen) of the host device do not trigger changes in the operation of adaptable input device 100.

[0037] Sensor(s) 106 are also capable of generating and outputting a signal that is indicative of a changed state of the host device. The signal is received by processor 104, which, in accordance with its programming, changes the operation of adaptable input device 100 (e.g., changes its functionality, changes the cursor/insertion point response to movement of pointing device 102A, etc.) as appropriate. It is within the capabilities of those skilled in the art to select, for use as sensor(s) 106 any of a wide of variety sensors, such as those operating based on mechanical, optical, or magnetic principles, among others.

[0038] FIG. 2 depicts a flowchart of method 200 for changing an aspect of the operation of an input device in response to a change in state of a host device.

[0039] Task 202 comprises detecting a change in a state of a host device. This task is performed, for example, by sensor(s) 106. Once a change is detected, a signal that is indicative of the change is generated, as per task 204. Typically, the sensors generate the signal.

[0040] In response to the signal, an aspect of the operation of an input device, such as pointing device 102, is changed, in accordance with task 206. As previously disclosed, the aspect of operation can pertain to the functionality of the input device, the response of cursor and/or insertion point to movement of the input device, or the like.

[0041] Having described the basics of adaptable input device 100, disclosure pertaining to the illustrative host device—portable terminal 300—is now presented.

[0042] FIG. 1 depicts a portable terminal 300. Portable terminal 300 provides both wireless telecommunications capabilities and personal computing (i.e., PDA-type) capabilities. With regard to its telecommunications capabilities, portable terminal 300 is capable of transmitting and receiving both voice and data with wireless base stations (not shown) or other wireless terminals, or both. Additionally, portable terminal 300 is capable of supporting telecommunications with wireline terminals through a wireless base station and wireline infrastructure. As to its personal computing capabilities, portable terminal 300 provides typical PDA computing and storage capabilities, including, without limitation, scheduling, address book storage and retrieval, note-taking, and an ability to run a variety of application software packages (e.g., calculators, games, etc.).

[0043] The design and operation of the basic circuitry and components (e.g., control circuitry, transceiver, antenna, speaker, microphone, display screen, keyboard, infrared transceiver, power supply, etc.) of a portable terminal having telecommunications and personal computing capabilities are quite familiar to those skilled in the art. Consequently, the basic circuitry and components will not be described here other than to provide context for the illustrative embodiment of the present invention.

[0044] With reference to **FIGS. 3 through 6D**, portable terminal **300** includes display **308** and keyboard-housing **312**. The keyboard-housing consists of cover **314** and a portion of base **416** (see **FIG. 4**). Display **308** has a display screen **310**, which is advantageously an LCD screen.

[0045] Portable terminal **300** can be used in either of two basic states: "closed," as depicted in **FIGS. 3, 4, 6A, and 7**, or "open," as depicted in **FIGS. 5 and 6D**. Display **308** is fully visible to a user when portable terminal **300** is closed and also when it's open. Portable terminal **300** includes keyboard-open sensor **106A** (see, **FIGS. 6B, 6C**), which is a device or circuit that senses if the portable terminal is open (or closed). As described in more detail later in this specification, keyboard-open sensor **106A** can be used to trigger certain changes in operation that are required as a function of a state (open or closed) of portable terminal **300**. The keyboard-open sensor can be suitably implemented in any of variety ways known to those skilled in the art (e.g., as a mechanical sensor, as an optical sensor, etc.).

[0046] As is perhaps most clearly shown in **FIG. 4**, display **308** and base **416** are, in the illustrative embodiment, unified as a single, non-separable part. Cover **314** is rotatably connected to base **416** (and display **308**) at pivot **420**. By virtue of pivot **420**, cover **314** is capable of rotating "out-of-plane" (of base **416**) about pivot axis **1-1** between a fully closed position (e.g., **FIG. 3**, etc.) and a fully-open position (e.g., **FIG. 5**, etc.). (See, **FIGS. 6A through 6D** showing rotation from fully closed to fully open.) This "out-of-plane" rotation exposes the underside of cover **314**, which includes portion **524** of a "split" keyboard.

[0047] When portable terminal **300** is closed, it is used in the manner of a conventional wireless terminal to send and receive calls. In this state, cover **314** is superposed over base **416** so that they coincide (i.e., defining keyboard-housing **312**) and serve as a handle for gripping portable terminal **300** (in the manner of a conventional wireless phone).

[0048] When portable terminal **300** is open, both the telecommunications capabilities and the PDA capabilities (e.g., address book, schedule, etc.) of portable terminal **300** are accessible. As previously described, to open portable terminal **300**, cover **314** is rotated out-of-plane, away from base **416**, as illustrated in **FIGS. 6B and 6C**.

[0049] Once opened, the keyboard of portable terminal **300** is exposed. In the illustrative embodiment, the keyboard (e.g., qwerty, etc.) is implemented in two portions, keyboard portion **522** and keyboard portion **524**. Keyboard portion **522** is disposed within base **416** and keyboard portion **524** is disposed within cover **314**. When portable terminal **300** is in the open position, display **310** is disposed between keyboard portion **522** and keyboard portion **524**.

[0050] Keyboard portions **522** and **524** advantageously provide a set of keys **525** for inputting the alpha characters of a language (e.g., English, etc.). The keyboard also advantageously includes one or more linearly-arranged keypads for inputting numbers, and additional function keys (e.g., keys that access certain applications, such as an address book, schedule, note taker, etc., or that provide an ability to scroll, etc.) Additionally, keyboard portions **522** and **524** advantageously include keys that access various telecommunications functions (i.e., the ability to place a call, the ability to receive a call, etc.). In the illustrative embodiment,

each of the keyboard portions contains about one-half the total number of keys. In some variations of the illustrative embodiment, the keys are unequally distributed between the two keyboard portions.

[0051] Portable terminal **300** also includes input device(s) **102**, which comprise key(s) or other elements (e.g., a joystick, etc.). These keys or other elements are not physically co-located with the group of keys that define the keyboard. In some embodiments, the information provided by input device **102** is different than the information that can be provided via the keys in the keyboard. For example, in some embodiments, input device **102** is a pointing device that moves a cursor and/or insertion point in display screen **310**. These additional input devices **102** are a focus of the illustrative embodiment of the present invention and are described in further detail below.

[0052] Additional description of portable terminal **300** (e.g., basic circuitry, components, the operation of same, etc.) is provided in U.S. patent application Nos. 60/359,199, 60/359,200, 10/161,831, and 10/207,643, all of which are incorporated by reference herein.

[0053] Input Device Having A Functionality That Depends on a State of the Portable Terminal

[0054] In accordance with the illustrative embodiment of the present invention, the function of input device(s) **102** depend upon whether portable terminal **300** is open or closed. By way of example and with reference to **FIG. 5**, consider four input devices that are disposed on cover **314** and that are realized as "buttons" **726A, 726B, 726C, and 726D** (collectively "buttons **726**").

[0055] When portable terminal **300** is closed, buttons **726** are used to access the telecommunications capabilities of the portable terminal. But when portable terminal **300** is open, these buttons function as pointing devices, wherein each button is capable of moving an on-screen cursor and/or insertion point in a different direction.

[0056] For example, in some embodiments, when portable terminal **300** is closed, button **726A** is used to answer a call and button **726C** is used to access various menus (e.g., a listing of most recent calls, a phone book, etc.). Button **726B** is used to select a function that appears on the lower left-hand side of display screen **310** (within a given menu), and button **726D** is used to select a function that appears on the lower right-hand side of the screen **310** (within a given menu). When button **726B** is used to select a function, button **726D** provides scrolling capability. When button **726D** is used to select a function, button **726B** provides scrolling capability.

[0057] When portable terminal **300** is open, however, button **726A** is used to move the cursor "down" (from the perspective of a viewer looking at the display screen as it appears in **FIG. 5**), button **726C** is used to move the cursor "up," button **726B** is used to move the cursor toward the "left," and button **726D** is used to move the cursor toward the "right."

[0058] It is notable that, from the perspective of a user, when portable terminal **300** is open, buttons **726** are located on the "back" side of cover **314**. That is, input device **102** is on the back of the keyboard (i.e., the back of keyboard portion **524**). This is in contrast to a typical arrangement

wherein the pointing device is co-located among the keys of the keyboard or otherwise on the same side of the keyboard as the keys.

[0059] Pointing Device Having a Directionality that is a Function Of a State of the Portable Terminal

[0060] In some embodiments of portable terminal 300, input device(s) 102 function as a pointing device when the terminal is open and when it is closed. In these embodiments, the direction in which a cursor and/or insertion point moves in response to a particular movement or attitude of the pointing device advantageously changes as a function of:

- [0061] whether the portable terminal is open or closed, and
- [0062] the orientation of the portable terminal (i.e., horizontal or vertical).

[0063] This change in cursor response as function of these state changes, and the reasons for it, is described below in conjunction with FIGS. 8-11.

[0064] In these embodiments, adaptable input device 100 is an adaptable pointing device 100A. Adaptable pointing device 100A includes pointing device 102A, processor 104, and sensor(s) 106 (see, FIG. 1). In the description that follows, the term adaptable pointing device (“APD”) 100A will be used generically to refer to both the pointing device itself (i.e., pointing device 102A) and the adaptable pointing device (i.e., pointing device 102A, processor 104, sensor 106) for simplicity.

[0065] FIG. 8 depicts portable terminal 300 closed and in a vertical orientation. As used in this specification, the term “vertical” is used to describe the orientation of the portable terminal 300 that is illustrated in FIG. 8, wherein, from a user’s perspective, base 416 extends “below” display 308. This state of portable terminal 300—closed and in a vertical orientation—is a reference position for mapping the movement of a cursor and/or insertion point in display screen 310 to movement of pointing device 102A.

[0066] A user’s view or perspective of portable terminal 300, and more particularly of display screen 310, is indicated by the relative direction (i.e., relative to a user’s perspective) “UP,” “DOWN,” “RIGHT,” and “LEFT,” as shown in FIG. 8. Reference locations “NORTH,” “SOUTH,” “EAST,” and “WEST” are defined for display screen 310. These reference locations refer to specific portions of display screen 310; that is, they do not change as the orientation of portable terminal 300 changes.

[0067] The movement of APD 100A is defined in terms of reference positions “1,” “2,” “3,” and “4,” as shown in FIG. 8. From a user’s perspective of closed, vertically-oriented portable terminal 300, movement of APD 100A toward position “1” is a movement “UP,” movement toward position “2” is a movement toward the “RIGHT,” movement toward position “3” is a movement “DOWN,” and movement toward position “4” is a movement toward the “LEFT.”

[0068] The movement of the cursor and/or insertion point in display screen 310 is mapped to movement of APD 100A in known fashion. It is advantageous for the cursor and/or insertion point to move in the same relative direction as APD 101A (the APD advantageously moves in the manner of a “joystick”). That is, when APD 100A is moved in a (relative)

direction that is perceived by a user to be “UP,” for example, the cursor and/or insertion point should move in a direction that the user perceives to be “UP.”

[0069] A reference mapping of cursor/insertion point movement to APD movement is shown below in the illustration and in Table 1. By way of example, and with continued reference to FIG. 8 and the illustration below, moving APD 100A toward position “1” causes the cursor and/or insertion point to move toward the portion of display screen 310 that is identified as “NORTH.” When portable terminal 300 is in its reference state (i.e., closed and vertical), a user viewing display screen 310 perceives movement of APD 100A toward the position “1” as a movement “UP.” The user also perceives the movement of the cursor and/or insertion point toward the region of display screen 310 that is identified as “NORTH” as movement “UP.” Consequently, the cursor and/or insertion point moves in a relative direction that is consistent with the movement of APD 100A, as is desired.

Reference Mapping For a Closed, Vertically Oriented Portable Terminal

[0070]

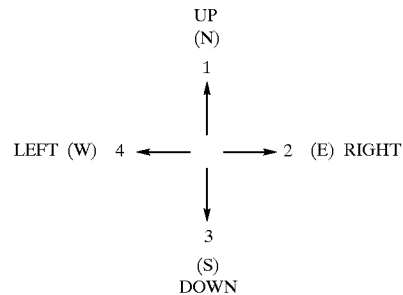

[0071] As an alternative to a joystick, four buttons could be used for movement toward reference positions “1,” “2,” “3,” and “4.” (See, e.g., FIG. 7, buttons 726A, 726B, 726C, and 726D).

[0072] Table 1 below summarizes the relationship between the movement of APD 100A and the movement of the cursor and/or insertion point in display screen 310 when portable terminal 300 is in the reference state (closed and in a vertical orientation).

TABLE 1

Mapping Cursor/IP Movement to APD Movement State of Portable Terminal: “Closed” & “Vertical”			
Movement of APD (Ref. Dir.)	Perceived Movement of APD	Movement of Cursor/IP in Display Screen (Ref. Dir.)	Perceived Movement of Cursor/IP
1	UP	NORTH	UP
2	RIGHT	EAST	RIGHT
3	DOWN	SOUTH	DOWN
4	LEFT	WEST	LEFT

[0073] Table 1 includes an entry for “Movement of APD (Ref. Dir.)” The movement is indicated in terms of the

reference positions for APD 100A, which are “1,” “2,” “3,” or “4.” A second column entitled “Perceived Movement of APD” indicates the relative (i.e., apparent) direction of movement (i.e., “UP,” “RIGHT,” etc.) of APD 100A from a user’s perspective. A third entry entitled “Movement of Cursor/IP in Display Screen (Ref. Dir.)” provides the cursor’s and/or insertion point’s movement toward a reference location in response to movement of APD 100A. A fourth entry entitled “Perceived Movement of Cursor/IP” indicates the relative (i.e., apparent) direction of movement (i.e., “UP,” “RIGHT,” etc.) of the cursor and/or insertion point from a user’s perspective. As previously indicated, it is desirable for the “Perceived Movement of APD” and the “Perceived Movement of Cursor/IP” to be the same.

[0074] Consider what happens when portable terminal 300 is opened (see, FIGS. 9, 10 and 11). In FIG. 9, a user’s perspective of portable terminal 300 is the same as shown for FIG. 8 (i.e., portable terminal 300 is in a vertical orientation). Consequently, a user’s sense of the relative directions “UP,” “RIGHT,” etc., with respect to display screen 310, does not change relative to FIG. 8.

[0075] On the other hand, the position of APD 100A relative to display screen 310 does change, as is evident from FIG. 9. This change is due to the 180-degree rotation of cover 314 (i.e., to open portable terminal 300). Although the position of APD 101A has changed relative to display screen 310, the cursor still moves in accordance with the reference mapping. It is notable that after rotation, APD 100A is accessed from the “back” side of keyboard portion 322.

[0076] The illustration that is shown immediately below and left shows the reference locations (bracketed) for display screen 310 and also a user’s perspective (i.e., the relative directions “UP,” etc.) of the display screen. The illustration below and right shows the orientation of APD 101A (relative to display screen 310) when the portable terminal is open and in a vertical orientation.

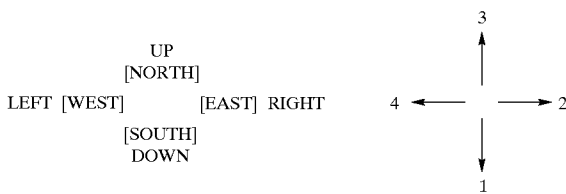

[0077] A problem manifests itself as a user moves APD 100A in the directions “1” or “3.” In particular, the illustration shows that a user perceives movement of APD 100A toward position “1” to be movement in the relative direction “DOWN.” But the response of the cursor and/or insertion point to movement in direction “1” is to move toward the reference location “NORTH” in accordance with the reference mapping. But as shown in the illustration on the left, the reference location “NORTH” is perceived to be “UP.” Similarly, as the user moves APD 100A to position “3,” which the user now perceives as a movement “UP,” the cursor and/or insertion point moves toward the reference location “SOUTH,” which the user perceives to be “DOWN.” In other words, the actual response of the cursor

and/or insertion point is the inverse of the desired response. This result, which is very undesirable, is summarized below by the entries in columns 1 through 4 of Table 2.

TABLE 2

Mapping Cursor/IP Movement to APD Movement State of Portable Terminal: “Open” & “Vertical”					
		BEFORE CORRECTION		AFTER CORRECTION	
Movement Of APD (Ref. Dir.)	Perceived Movement Of APD	Movement Of Cursor/IP in Display Screen (Ref. Dir.)	Perceived Cursor Movement	Movement Of Cursor/IP In Display Screen (Ref. Dir.)	Perceived Cursor Movement
1	DOWN	NORTH	UP	SOUTH	DOWN
2	RIGHT	EAST	RIGHT	EAST	RIGHT
3	UP	SOUTH	DOWN	NORTH	UP
4	LEFT	WEST	LEFT	WEST	LEFT

[0078] As a consequence of this inverted response, the response of the cursor and/or insertion point to movement of APD 100A must be changed or re-mapped. This is referred to herein as “altering directionality.” Specifically, when portable terminal 300 is open and in a vertical orientation (see, FIG. 9), the cursor and/or insertion point response is changed so that moving APD 100A to reference position “1” causes the cursor and/or insertion point to move toward the reference location “SOUTH” in screen 310. The perceived movement of the cursor and/or insertion point, which is now “DOWN,” corresponds to the perceived movement of APD 100A. Similarly, the cursor and/or insertion point response is changed so that moving APD 100A to reference position “3” causes the cursor and/or insertion point to move toward the reference location “NORTH” in display screen 310. The corrected response (altered directionality) is indicated in the fifth and sixth columns of Table 2. When the response is corrected, the second column, “Perceived Movement of APD” and the sixth column, “Perceived Cursor/IP Movement” are the same.

[0079] It is atypical for portable terminal 300 to be used in a vertical orientation (FIG. 9) when it’s open. In fact, when it is open, portable terminal 300 is more likely to be used in a “horizontal” orientation, such that a user’s view of the portable terminal is as depicted in FIGS. 10 and 11.

[0080] When portable terminal 300, as depicted in FIG. 9, is turned sideways or horizontal for use as depicted in FIGS. 10 and 11, the correspondence between relative directions (i.e., “UP,” “DOWN,” etc.) and reference locations (i.e., “NORTH,” “SOUTH,” etc.) changes. For example, reference location “NORTH” would appear to be toward the “RIGHT,” rather than “UP.” Similarly, the reference location “EAST” would appear to be “DOWN,” rather than “RIGHT,” etc. More particularly, the relative directions of all the reference locations shift clockwise by ninety degrees. This is undesirable because the image that appears in the screen will no longer be “right-side up” from the perspective of a user.

[0081] Consequently, when portable terminal 300 is used in this “horizontal” orientation, it is advantageous to mechanically rotate display 308, or, equivalently, to electronically rotate the image in display screen 310. Doing so

causes any images that appears in display screen 310 to be "right-side up". In FIG. 10, display 308 is physically rotated counterclockwise by ninety degrees relative to the position of display 308 shown in FIG. 9. In FIG. 11, images that appear in display screen 310 are electronically rotated counterclockwise by ninety degrees relative to images that appear in display screen 310 of the portable terminal that is shown in FIG. 9. Mechanical rotation of display 308 and electronic rotation of an image in display screen 310 is described in applicant's co-pending U.S. patent application Ser. No. 10/207,643.

[0082] The open, horizontal state of portable terminal 300 involves two changes from the reference state (i.e., closed and vertical). In particular, the portable terminal is (1) opened and (2) it is typically rotated clockwise by ninety degrees. For pedagogical purposes, the correction that is to be applied to cursor and/or insertion point movement to improve usability of portable terminal 300 is broken down into two sub-corrections, as follows:

[0083] Re-mapping, from "NORTH" to "SOUTH," the response of the cursor and/or insertion point to movement of APD 100A toward reference position "1" and re-mapping, from "SOUTH" to "NORTH," the response of the cursor to movement of APD OOA toward reference position "3."

[0084] Re-mapping, by a clockwise shift of ninety-degrees, the response of the cursor and/or insertion point to movement of APD 100A toward any of the four reference positions.

[0085] The first sub-correction is applied to account for the change in state of portable terminal 300 from "closed" to "open," as previously described. The second sub-correction is applied to account for the change in state of portable terminal 300 from "vertical" to "horizontal." The latter correction is required because it is assumed that display 308, or the image in display screen 310, is rotated as described above. The same correction is applied for both cases (i.e., physical rotation of display 308 and electronic rotation of the image in display screen 310).

[0086] The two illustrations provided below serve as an aid to understanding the need for re-mapping the response of the cursor and/or insertion point. The illustration that appears immediately below and left shows the reference locations (bracketed) for display screen 310 and also a user's perspective (i.e., relative directions "UP," etc.) of the display screen when it's in the horizontal (and open) position. The illustration below and right shows the orientation of APD 100A relative to display screen 310 when the portable terminal is open and in a horizontal orientation.

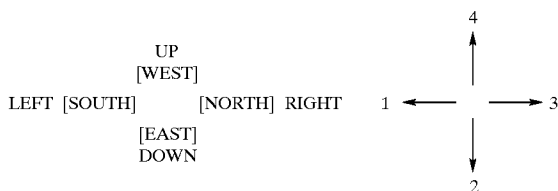

[0087] First, consider a scenario in which neither display 308 nor the image in display screen 310 has been rotated,

while the cursor and/or insertion point movement has been corrected for the change in state of portable terminal 300 from closed to open. For this scenario, the apparent direction of movement of the cursor and/or insertion point (e.g., "UP," "DOWN," etc.) is consistent with the apparent direction of movement of APD 100A toward any reference position. That is, when APD 100A is moved toward the reference position "4," the cursor and/or insertion point moves toward the reference location "WEST" in display screen 310. Movement toward the reference position "4" and movement toward the reference location "WEST" are advantageously both perceived as movements in the relative direction "UP." But since display 308 (or image in display screen 310) has not yet been rotated as previously described, an image (e.g., text, etc.) appearing in display screen 310 appears to be on its side.

[0088] Next, consider a scenario in which display 308, or images appearing in display screen 310, have been rotated counterclockwise by ninety degrees so that any images in display screen 310 appear to be "right-side up" to a user. This is rotation is shown in the illustration below:

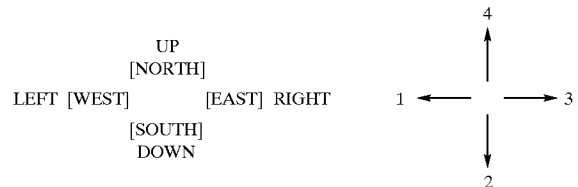

[0089] Since the display (image) is physically (electronically) rotated counterclockwise by ninety degrees, the reference positions "NORTH," etc., change relative to a user's perception of relative directions (i.e., "UP," etc.). In the absence of any change in mapping, movement of APD 101A toward the reference position "4" will cause the cursor and/or insertion point to move toward "WEST" in display screen 310. Before rotation, "WEST" is "UP," but after rotation, "WEST" is "LEFT." As a result of this rotation, the response of the cursor and/or insertion point to movement of APD 100A will be undesirably shifted counterclockwise by ninety degrees relative to the reference mapping. For example, when a user moves APD 100A toward position "4," which the user perceives to be "UP," the cursor will move toward the reference location "WEST," which the user perceives to be "LEFT."

[0090] Consequently, the directionality of APD 100A must be changed (i.e., the response of the cursor and/or insertion point must be re-mapped). Doing so results in a clockwise shift of ninety degrees in the response of the cursor and/or insertion point to movement of APD 100A. For example, after re-mapping, movement of APD 100A in the direction "4" results in a movement of the cursor and/or insertion point in the direction "NORTH," rather than "WEST," in accordance with the reference. After re-mapping, the image appears upright and the perceived movement of APD 100A and the cursor and/or insertion point are consistent with one another.

[0091] The information presented above concerning the correction to cursor and/or insertion point response for an

open, horizontally-oriented portable terminal (see, **FIGS. 10 and 11**) is summarized below in Table 3.

TABLE 3

Mapping Cursor Movement to APD Movement State of Portable Terminal:
"Open" Orientation of Portable Terminal: "Horizontal"

Move- ment of APD (Ref. Dir.)	BEFORE CORRECTION* (AFTER DISPLAY ROTATION)			AFTER CORRECTION	
	Perceived Movement Of APD	Movement of Cursor/IP in Display Screen (Ref. Dir.)	Perceived Cursor/IP Movement	Movement Of Cursor/IP In Display Screen (Ref. Dir.)	Perceived Cursor/IP Movement
1	LEFT	SOUTH	DOWN	WEST	LEFT
2	DOWN	EAST	RIGHT	SOUTH	DOWN
3	RIGHT	NORTH	UP	EAST	RIGHT
4	UP	WEST	LEFT	NORTH	UP

*Response is corrected for change in state from closed to open, but not from vertical to horizontal.

[0092] The change in directionality of APD **100A** can be triggered automatically or manually. For automatic alteration, keyboard-open sensor **106**, which senses when cover **314** is rotated, is used. When rotation is sensed by keyboard-open sensor **106**, processor **104** re-maps the response of the cursor and/or insertion point to movement of APD **100A**, as previously described. Furthermore, processor **104** rotates the images in display screen **310**, as appropriate. In embodiments in which display **308** is configured for manual, in-plane rotation, display-rotation sensor **106B** (**FIG. 10**) is advantageously used in conjunction with keyboard-open sensor **106A** (**FIGS. 6A-6D**) to cause the processor to re-map the response of the cursor and/or insertion point to movement of APD **100A**. As an alternative to using sensors, a user can simply depress a "hot" key or access a menu (neither depicted) that triggers the change in directionality of APD **100A**.

[0093] Portable Terminal Having Multiple Pointing Devices

[0094] In some variations of the illustrative embodiment, portable terminal **300** includes two pointing devices, one disposed on base **416** and the other on cover **314**. In other words, in addition to pointing device **102A**, there is a second pointing device **1230** that is accessed from the "back" of portable terminal **300** when it is in an open state. This is depicted in **FIG. 12**, which shows a back view of portable terminal **300**. The second pointing device enables a user to use a finger of the left hand to manipulate pointing device **1030**, as might be desired (e.g., by a left-handed person, etc.). In some variations, pointing device **1030** is part of a removable battery pack **418**.

[0095] It is to be understood that the above-described embodiments are merely illustrative of the present invention and that many variations of the above-described embodiments can be devised by those skilled in the art without departing from the scope of the invention. It is therefore intended that such variations be included within the scope of the following claims and their equivalents.

We claim:

1. An article comprising an adaptable input device, said adaptable input device comprising:

an input device for inputting information into a host device;

a sensor for detecting a change in a state of the host device; and

a processor for changing an aspect of the operation of said input device in response to said change in state.

2. The article of claim 1 wherein said aspect is a functionality of said input device.

3. The article of claim 2 wherein said state comprises a physical configuration of the host device.

4. The article of claim 3 wherein said state comprises a physical orientation of the host device.

5. The article of claim 1 wherein said input device is a pointing device.

6. The article of claim 5 wherein said aspect is a directionality of said pointing device.

7. The article of claim 6 wherein said state comprises a physical configuration of the host device.

8. The article of claim 6 wherein said state comprises a physical orientation of the host device.

9. The article of claim 1 wherein said host device is a portable terminal.

10. A portable terminal comprising:

a base;

a display, wherein said display is coupled to said base, and wherein said display has a display screen;

a cover, wherein said cover is rotatably coupled, for out-of-plane rotation, to at least one of either said display or said base;

an input device, wherein said input device inputs information into said portable terminal, and wherein said input device is disposed on said cover;

a sensor for detecting a change in a state of said portable terminal; and

a processor for changing an aspect of the operation of said input device in response to said change in state.

11. The portable terminal of claim 10 wherein said aspect is a functionality of said input device.

12. The article of claim 11 wherein said state comprises a physical configuration of said portable terminal.

13. The article of claim 11 wherein said state comprises a physical orientation of said portable terminal.

14. The article of claim 10 wherein said input device is a pointing device.

15. The article of claim 14 wherein said aspect is a directionality of said pointing device.

16. The article of claim 15 wherein said state comprises a physical configuration of said portable terminal.

17. The article of claim 15 wherein said state comprises a physical orientation of said portable terminal.

18. A method for changing an aspect of the operation of an input device, comprising:

detecting a change in a state of a host device;

generating a signal that is indicative of said change in state; and

changing an aspect of the operation of an input device responsive to said signal.

19. The method of claim 18 wherein the input device is a pointing device.

20. The method of claim 19 wherein said state is at least one of a physical configuration of said portable terminal and a physical orientation of said portable terminal.

* * * * *