

(12) **UK Patent Application** (19) **GB** (11) **2 314 164** (13) **A**

(43) Date of A Publication 17.12.1997

(21) Application No **9710515.9**

(22) Date of Filing **23.05.1997**

(30) Priority Data

(31) **9612096** (32) **10.06.1996** (33) **GB**

(71) Applicant(s)

The Secretary of State for Defence

(Incorporated in the United Kingdom)

**DRA Headquarters, Ively Road, Pyestock,
FARNBOROUGH, Hants, GU14 0LX, United Kingdom**

(72) Inventor(s)

**Terence Valentine Jones
David Robert Buttsworth**

(74) Agent and/or Address for Service

**S R Skelton
PO Box 702, Directorate of Int Prop Rights,
Formalities Section (Procurement Executive),
Poplar 2, MOD Abbey Wood 19, BRISTOL, BS12 7DU,
United Kingdom**

(51) INT CL⁶

G01K 13/02 , G01N 27/18

(52) UK CL (Edition O)

**G1N NAAJR NADCT NAEQ N1D13 N1M1 N7A1 N7C
N7K
U1S S1987**

(56) Documents Cited

US 4770037 A US 4538448 A US 4501145 A

(58) Field of Search

**UK CL (Edition O) G1N NACDT NACJ NADCT NAEQ
NAFB
INT CL⁶ G01K 13/02 , G01N 25/20 25/30 25/32 27/14
27/16 27/18**

(54) **A method and device to measure fluid parameters**

(57) A method and device to measure a fluid parameter such as the temperature or gas composition of a high temperature fluid and which have particular application to compressible unsteady flowing fluid and rapidly changing temperatures of high temperature gases, e.g. in a gas turbine engine duct, make use of at least two temperature sensing elements which are pre-set to different temperatures, and the parameter of the fluid is determined from temperature readings of said sensing elements taken at least two time instants. The method may be applied to the measurement of fluid temperature by determining differing heat transfer rates from the temperature history of temperature sensors initially set to different temperatures before exposure to the fluid. Using additional information from a Pitot probe, gas composition of binary flows can also be determined. A number of probe structures comprising a pair of temperature sensors are described, and different ways of pre-heating one of the sensors. The probe shown has sensors 15,16 each comprising a platinum film element at the end of a quartz rod, and a heater 17 to pre-heat one of the sensing elements.

Fig.5.

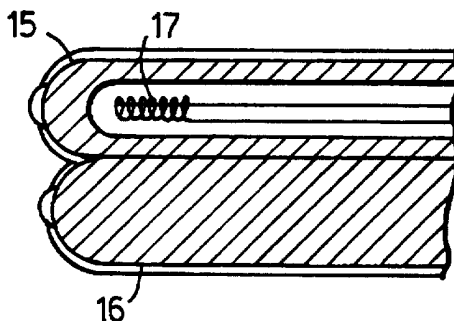

GB 2 314 164 A

1/2

Fig.1.

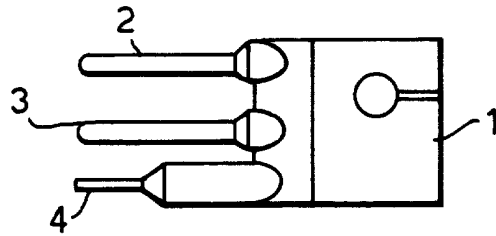

Fig.2.

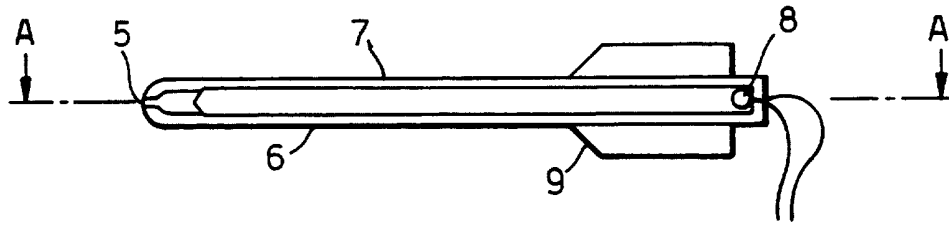
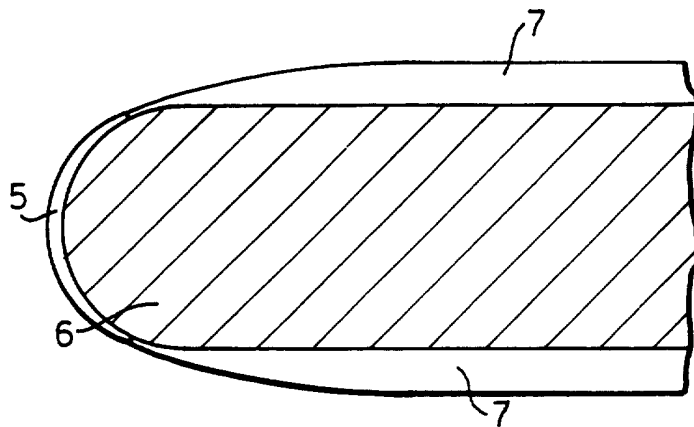

Fig.3.



2/2

Fig.4.

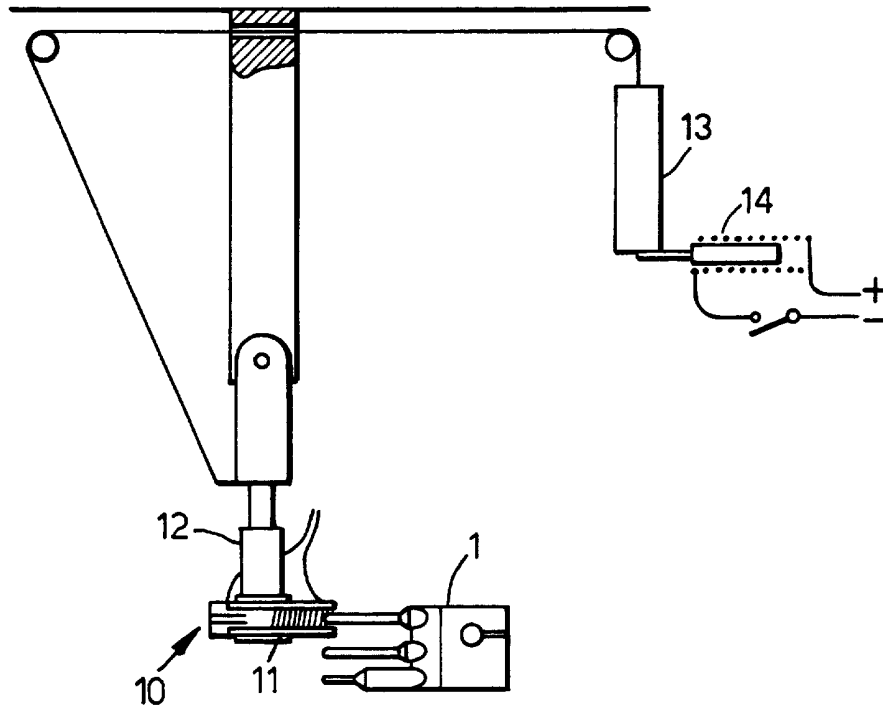

Fig.5.

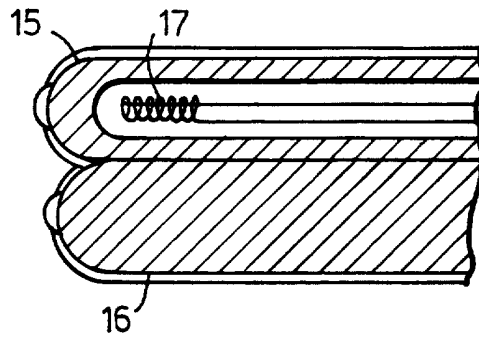
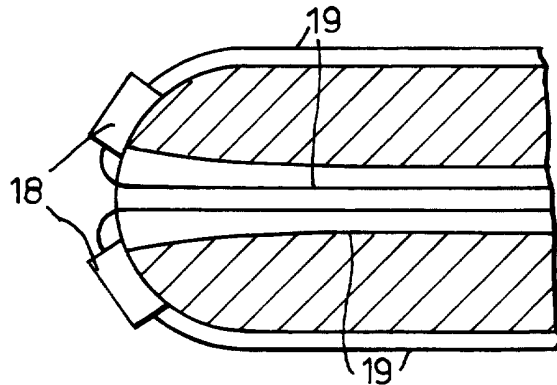

Fig.6.



Method and Device to Measure Fluid Parameters

This invention relates to a method and device to measure fluid parameters of gas composition and temperature. It has particular application for the measurement of rapidly varying temperature in unsteady, compressible fluids, for example gas flowing in gas turbine engine ducts. Another example is the measurement of transient variation in the temperature of a gas which is subject to shock waves.

Thermocouples are extensively used in many applications to provide accurate and low cost measurement of high temperatures. However their time response is poor due to thermal inertia effects and thus their use in temperature measurement of unsteady or fluctuating flowing fluids is restricted. Other devices, such as thin wire devices, have been used for temperature measurement but these are unsuitable for compressible or unsteady flows since the density, velocity, temperature and pressure of the flow (which are all required to obtain the temperature using these methods) vary independently with time. Optical pyrometry can only be used if optical access to the fluid is possible.

A device for temperature measurement in compressible flow using an aspirating probe has been described by Ng and Epstein in their paper "High Frequency Temperature and Pressure Probe for Unsteady Compressible flows" in Rev. Sci. Inst. Vol.54, No. 12, 1678-1683. This device comprises two constant temperature hot wires located upstream of a choked orifice. By operating the wires at different overheat ratios (probe temperature : flow recovery temperature), it is possible to temporarily resolve both pitot pressure and flow temperature variations in unsteady and fluctuating flow. The successful operation of the probe is dependant on establishing a steady flow in the aspirating channel leading up to and including a choked orifice both of which are parts of the probe itself. Calculation of flow establishment times and experimental measurements suggest that the upper frequency limit for this device is approximately 20kHz. It is an object of this invention to provide a temperature measuring device that is capable of high-frequency measurement of fluid temperature in unsteady and compressible flows.

The invention consists of a device for measuring the temperature of a fluid comprising at least two temperature sensing elements, means for pre-setting said elements to different temperatures, and means for determining the fluid temperature from temperature readings of said elements taken at at least two time instants.

The advantage of using two temperature sensing elements pre-set to different temperatures is that it enables a simple method of determining the temperature of the fluid to be implemented, whereby time-separated temperature measurements from said elements can be used to calculate the fluid temperature; and heat transfer coefficients do not need to be determined. The method eliminates re-calibration of the probe to determine heat transfer coefficients, and allows fluid temperature in flows of arbitrary composition to be measured.

If, as was previously done, just one temperature element is used to find the fluid temperature, the heat transfer coefficient has to be derived in complicated manner from the Nusselt number, which depends *inter alia* on flow characteristics and probe geometry. It also assumes steady flow with low free-stream turbulence.

This invention relies on the principle that convective heat transfer rate is approximately proportional to the difference between the surface temperature of the temperature sensing element and the temperature of the fluid. If the temperature sensing elements are each initially pre-set to different temperatures, the two different heat transfer rates can be determined by periodically taking measurements of the temperature sensing elements. Determining two heat transfer rates eliminates the need to calculate a heat transfer coefficient. The relationship between the heat transfer rate and the temperature difference is

$$q = h (T_t - T_w)$$

where q is heat transfer rate, h is the heat transfer coefficient and T_t and T_w are the temperature of fluid and probe element respectively.

The two measured surface temperatures of the first and second elements T_{w1} and T_{w2} respectively relate to the respective heat fluxes q_1 and q_2 as follows:

$$q_1 = h (T_f - T_{w1})$$

$$q_2 = h (T_f - T_{w2})$$

From the above equations

$$T_f = T_{w1} + q_1 (T_{w2} - T_{w1}) / (q_1 - q_2)$$

Thus the fluid temperature can be determined from the measured two temperatures and the heat transfer rates q_1 and q_2 . These heat transfer rates can be determined by sampling the temperatures of the temperature sensing elements at short intervals and prior knowledge of the heat diffusion characteristics of the elements, which can be routinely established. It is desirable to calibrate the elements over the whole range of the operating temperatures. Temperature calibrations can be expressed in the usual form (the secondary term may be omitted)

$$R/R_0 = 1 + \alpha (T - T_0) + \beta (T - T_0)^2$$

By way of example, a number of embodiments of the invention will now be described with reference to the figures of which :

Figure 1 shows the probe unit for use according to the invention.

Figure 2 is a more detailed view of a probe as described with reference to the above figure.

Figure 3 is a greatly enlarged partial cross section on the line A-A of Figure 2 and shows the tip of the probe shown in more detail.

Figure 4 shows the arrangement of a probe unit for use in accordance with the invention.

Figure 5 is a partly cut-away perspective view showing an alternative embodiment of the invention comprising a single probe.

Figure 6 shows a further embodiment of the invention which eliminates the need for a separate heating element.

Figure 1 shows the probe unit 1 according to the invention, on its own, which comprises two probes; a "hot" probe 2 and a "cold" probe 3, of similar construction and each having a temperature sensing element located distally (described later with reference to Figure 2). A pitot probe 4 is incorporated onto the probe unit juxtaposed with the other probes and orientated to point in the direction of flow when the probe unit is inserted into the flow.

Figure 2 shows in more detail the design of the probes. Each probe is narrow and cylindrical in its construction and made from quartz 6. At its tip, i.e. distally, it incorporates a temperature sensing element comprising a thin film of platinum 5 painted onto the fused quartz substrate. The probe has a diameter of approximately 3mm and the thin platinum film has a length of about 1mm. The platinum film has a thickness of approximately $0.5\mu\text{m}$ and a resistance of 20Ω . The probes are mounted on macor^(RTM) collars 9 prior to their installation.

Figure 3 shows in more detail the tip of the probe of Figure 2 and shows the thin platinum layer 5 on the quartz substrate 6. Electric leads 7 formed by a gold or silver paste are connected to the platinum film, and run to the cool end of the probe. These permit the sustained integrity of the solder which joins the electric wire 8 (see Figure 2) to the probes.

Figure 4 shows the probe unit 1 as described above in operation. In order to generate a difference between the surface temperature of the probes, prior to a temperature measurement run, a pre-heating unit 10 is used to pre-heat one of the probes (hereafter referred to as "the hot probe"). Power from a 7V source (not shown) is supplied to an aluchrome heating coil 11 incorporated in the pre-heating unit and having a resistance of 2Ω . Insulation round the heating coil is provided by an oxide ceramic sheath.

In operation for the measurement of rapid temperature changes, before measurements are taken, the hot probe is heated by passing a current through the coil of the pre-heating unit. Immediately before the run, the heating unit, which is

mounted on a pivoted member 12, is swung clear of the probes under the action of a weight 13 connected by wire to the member 12, and controllably released by a solenoid latch 14. This causes the pre-heating unit to rotate about the pivot and retract from the hot probe and additionally allows the probe unit to be driven into position or to traverse the fluid flow if required. Temperature readings are taken from both probes at periodic intervals and fed to a suitable data logging device which is connected to a computer so that heat transfer rates and thereby fluid temperature can be calculated from the readings from the temperature sensor elements.

Figure 5 shows a further embodiment of the invention which comprises a single probe comprising two segments 15, 16. Each segment of the probe has an essentially similar construction to the probe described above. The quartz rod of one segment 15 of the probe is hollow and a heating element 17 is located distally therein; i.e. adjacent to the thin platinum film temperature sensing element. Before a temperature measurement run, a current is passed through the heating element so that the temperature sensing element (essentially a heat transfer gauge) is heated to a higher temperature than the temperature sensing element located in the other segment of the probe.

Figure 6 shows an even simpler embodiment of the invention wherein a single probe comprises temperature sensing elements located distally and externally as in the probes described above. The temperature sensing elements 18 are platinum resistance elements as described above. The separate heating element used to pre-heat one of the temperature sensing elements required in the above embodiment is dispensed with. The temperature sensing elements are pre-set to different temperatures prior to a temperature measurement run by passing differing currents through the temperature sensing elements to heat that element to a higher temperature than the other temperature sensing element. Being a resistance temperature sensing element (resistance thermometer) it can act as a heater to heat itself, i.e. the heating element and the temperature sensing element are one and the same. A pair of leads 19 is provided for each element as before.

The temperature probe described also has application in measuring gas composition in binary gas flows. Gas composition measurements are needed, for example, in the analysis of mixing and combusting flows, such as those which occur in scram jet engines. As described above the convective heat transfer coefficient, h is given by:

$$h = (q_1 - q_2) / (T_{w2} - T_{w1})$$

It is possible to establish relationships between the heat transfer coefficient, the Pitot pressure of the gas flow, the geometry of the probe and the gas composition. Therefore if a Pitot tube is provided on the probe then the gas composition can also be determined.

For example, for the case of a hemispherical ended (round-tipped) probe in a hypersonic flow the convective heat transfer coefficient is

$$h = C \sqrt{(p_{\text{pit}} / r)}$$

where p_{pit} is the Pitot pressure, r is the radius of the probe and C is a strong function of the gas composition but only a weak function of the flow total temperature; gas composition can be determined from C .

For other probe geometries it is prerequisite to formulate a relationship between convective heat transfer coefficient, Pitot pressure and gas composition dependent on the probe geometry.

The concentration probes are essentially identical to the temperature probes described above but also include means to measure Pitot pressure.

Claims

1. A fluid measurement device comprising at least two temperature sensing elements, means for pre-setting said elements to different temperatures, and means for determining a parameter of the fluid from temperature readings of said sensing elements taken at least two time instants.
2. A device as claimed in claim 1 wherein said temperature sensing elements are resistance thermometers.
3. A device as claimed in claim 2 wherein said temperature sensing elements are thin film heat transfer gauges.
4. A device as claimed in claim 3 wherein said thin film heat transfer gauge includes a thin platinum film.
5. A device as claimed in any of claim 4 wherein said film is less than $1\mu\text{m}$ thick.
6. A device as claimed in any of claims 1 to 5 wherein said means for initially setting said temperature sensing elements comprises heating means adapted to heat at least one of said elements.
7. A device as claimed in any of claims 1 to 6 wherein said temperature sensing elements are located on at least two separate probes.
8. A device as claimed in claim 7 wherein said means to pre-set said temperature sensing elements comprise a retractable heating unit adapted to receive at least one probe.

9. A device as claimed in any of claims 1 to 6 wherein said temperature sensing elements are located on the same probe.
10. A device as claimed in any of claims 6, 7 or 9 wherein said heating means are provided by the temperature sensing element itself.
11. A device as claimed in any of the above claims additionally including a Pitot tube.
12. A method of determining the temperature of a fluid comprising:
- (a) pre-setting at least two temperature sensing elements to different temperatures;
 - (b) taking temperature measurements from said elements at least two time instants after exposure to the fluid whose temperature is to be measured; and
 - (c) from said measurements calculating the temperature of the flow.
13. A method of determining the temperature of a fluid as claimed in claim 12 wherein step (c) uses the relationship:

$$T_t = T_{w1} + q_1 (T_{w2} - T_{w1}) / (q_1 - q_2)$$

where T_t is the temperature of the fluid, T_{w1} is the temperature of one element, T_{w2} is the temperature of a second element and q_1 and q_2 are the heat transfer rates of the first and second elements respectively.

14. A method of determining the concentration of gas in binary gas flows comprising:
- (a) pre-setting at least two temperature sensing elements at different temperatures;
 - (b) taking temperature measurements from said elements at least two time instants when said elements are exposed to the flow;
 - (c) from said measurements calculating the convective heat transfer coefficient;
 - (d) determining the Pitot pressure in the location of the elements; and,
 - (e) calculating the gas composition from the convective heat transfer coefficient, the Pitot pressure, and the probe geometry.
15. A method of determining the concentration of gas in a mixture gases as claimed in claim 16 wherein said elements are located on at least one hemispherical probe and wherein step (e) includes calculating the value of the constant C where

$$C = \sqrt{(p_{\text{pit}} / r)}$$

where r is the radius of a hemispherical probe used in the determination, and determining the gas composition from C.



Application No: GB 9710515.9
Claims searched: 1-15

Examiner: M.G. Clarke
Date of search: 29 July 1997

**Patents Act 1977
Search Report under Section 17**

Databases searched:

UK Patent Office collections, including GB, EP, WO & US patent specifications, in:
UK CI (Ed.O): G1N NACDT, NACJ, NADCT, NAEQ, NAFB
Int CI (Ed.6): G01K 13/02; G01N 25/20, 25/30, 25/32, 27/14, 27/16, 27/18
Other: -----

Documents considered to be relevant:

Category	Identity of document and relevant passage	Relevant to claims
X	US 4770037 assigned to Battelle Memorial Institute - whole document	1,2,6,7,10 at least
A	US 4538448 assigned to Charbonnages de France - whole document, but see especially column 5 lines 33-52	
A	US 4501145 assigned to Battelle Memorial Institute - whole document	

X	Document indicating lack of novelty or inventive step	A	Document indicating technological background and/or state of the art.
Y	Document indicating lack of inventive step if combined with one or more other documents of same category.	P	Document published on or after the declared priority date but before the filing date of this invention.
&	Member of the same patent family	E	Patent document published on or after, but with priority date earlier than, the filing date of this application.