



- (51) International Patent Classification:
G01B 7/16 (2006.01)
- (21) International Application Number:
PCT/US2016/027968
- (22) International Filing Date:
15 April 2016 (15.04.2016)
- (25) Filing Language: English
- (26) Publication Language: English
- (71) Applicant: **HEWLETT-PACKARD DEVELOPMENT COMPANY, L.P.** [US/US]; 11445 Compaq Center Drive W., Houston, Texas 77070 (US).
- (72) Inventors: **CHAFFINS, Sterling**; 1070 NE Circle Blvd., Corvallis, Oregon 97330-4239 (US). **DEKAM, Kevin P.**;

1070 NE Circle Blvd., Corvallis, Oregon 97330-4239 (US). **ROOP, Cassidy Sparks**; 1070 NE Circle Blvd., Corvallis, Oregon 97330-4239 (US).

(74) Agents: **ESTEBAN, Michelle** et al.; HP Inc., Intellectual Property, 3390 E. Harmony Road, Mail Stop 35, Fort Collins, Colorado 80528 (US).

(81) Designated States (unless otherwise indicated, for every kind of national protection available): AE, AG, AL, AM, AO, AT, AU, AZ, BA, BB, BG, BH, BN, BR, BW, BY, BZ, CA, CH, CL, CN, CO, CR, CU, CZ, DE, DK, DM, DO, DZ, EC, EE, EG, ES, FI, GB, GD, GE, GH, GM, GT, HN, HR, HU, ID, IL, IN, IR, IS, JP, KE, KG, KN, KP, KR, KZ, LA, LC, LK, LR, LS, LU, LY, MA, MD, ME, MG, MK, MN, MW, MX, MY, MZ, NA, NG, NI, NO, NZ, OM, PA, PE, PG, PH, PL, PT, QA, RO, RS, RU, RW, SA, SC,

[Continued on next page]

(54) Title: STRAIN SENSORS

(57) Abstract: A strain sensor can include a resistor, a first electrical contact at a first end of the resistor, and a second electrical contact at a second end of the resistor. The resistor can be formed of a matrix of sintered elemental transition metal particles interlocked with a matrix of fused thermoplastic polymer particles.

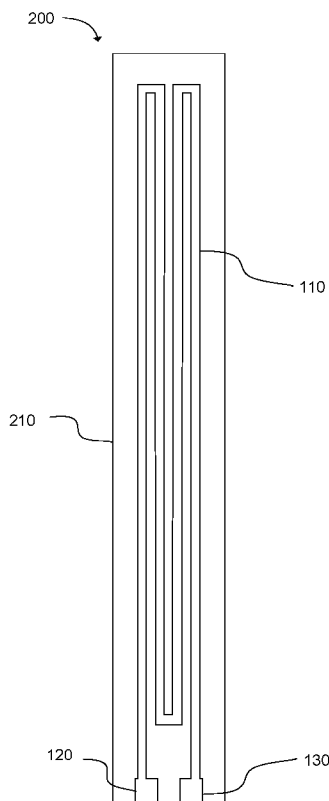

FIG. 2





SD, SE, SG, SK, SL, SM, ST, SV, SY, TH, TJ, TM, TN, TR, TT, TZ, UA, UG, US, UZ, VC, VN, ZA, ZM, ZW.

(84) Designated States (unless otherwise indicated, for every kind of regional protection available): ARIPO (BW, GH, GM, KE, LR, LS, MW, MZ, NA, RW, SD, SL, ST, SZ, TZ, UG, ZM, ZW), Eurasian (AM, AZ, BY, KG, KZ, RU, TJ, TM), European (AL, AT, BE, BG, CH, CY, CZ, DE, DK, EE, ES, FI, FR, GB, GR, HR, HU, IE, IS, IT, LT, LU, LV, MC, MK, MT, NL, NO, PL, PT, RO, RS, SE, SI, SK, SM, TR), OAPI (BF, BJ, CF, CG, CI, CM, GA, GN, GQ, GW, KM, ML, MR, NE, SN, TD, TG).

Declarations under Rule 4.17:

- as to the identity of the inventor (Rule 4.17(i))
- as to applicant's entitlement to apply for and be granted a patent (Rule 4.17(ii))

Published:

- with international search report (Art. 21(3))

5

STRAIN SENSORS

BACKGROUND

[0001] Strain sensors are commonly used to measure strain, or in other words, the amount of compression or extension of an object under an applied force. Many types of measurement devices use a strain sensor to measure another quantity, such as pressure, load, torque, and weight. A common type of strain sensor utilizes the common property that the electrical resistance of a material depends on the material's length and cross-sectional area. Strain sensors often consist of a metal foil pattern bonded to a substrate material. Such strain sensors are placed in such a way that the strain being measured will cause the metal foil pattern to flex. Depending on the direction of flexing, the metal foil pattern can be subjected to compressive or tensile forces. When the metal foil pattern is compressed, the length of the metal foil pattern is slightly reduced and the thickness is slightly increased, which results in an overall reduction in resistance. When the metal foil pattern is under tensile stress, the length of the metal foil pattern increases slightly and the thickness is slightly reduced, resulting in an increase in resistance. These small changes in resistance can be detected and correlated to the strain experienced by the strain sensor.

25

BRIEF DESCRIPTION OF THE DRAWINGS

[0002] FIG. 1 is a top plan view of a 3-dimensional printed strain sensor in accordance with examples of the present disclosure;

30

[0003] FIG. 2 is a top plan view of a 3-dimensional printed part having an integrated strain sensor in accordance with examples of the present disclosure;

[0004] FIG. 3 is a close-up side cross-sectional view of a layer of thermoplastic polymer powder with a conductive fusing ink printed on a portion of

the layer in accordance with examples of the present disclosure;

[0005] FIG. 4 is a close-up side cross-sectional view of the layer of FIG. 3 after the layer has been cured in accordance with examples of the present disclosure;

5 [0006] FIG. 5 is a flow chart illustrating a method of making a 3-dimensional printed part having an integrated strain sensor in accordance with examples of the present disclosure;

[0007] FIG. 6A is a side plan view of a 3-dimensional printed part having an integrated strain sensor in accordance with examples of the present
10 disclosure; and

[0008] FIG. 6B is a front plan view of the 3-dimensional printed part of FIG. 6A rotated 90 degrees in accordance with examples of the present disclosure.

[0009] The figures depict several examples of the presently disclosed technology. However, it should be understood that the present technology is not
15 limited to the examples depicted.

DETAILED DESCRIPTION

[0010] The present disclosure is drawn to the area of strain sensors and
20 3D printing. More specifically, the present disclosure provides 3-dimensional printed strain sensors, 3-dimensional printed parts with integrated strain sensors, and methods of printing the parts.

[0011] Typical strain sensors are discrete components that are normally fastened to a surface under investigation using adhesives or fasteners. For
25 example, to measure strain in a structural beam, strain sensors can be placed on surfaces of the beam transverse to the direction the beam is expected to bend in order to measure flexion of the beam.

[0012] The present technology provides strain sensors. These strain sensors can be integrated during the design of a 3-dimensional printed object
30 and printed as a part of the finished object itself. Thus, strain sensor components can be integrated to a part without using adhesives or fasteners. By eliminating the separate strain sensor component, the complexity and cost of a system using the strain sensor can be reduced. Potential cost efficiencies include the

elimination of manufacturing steps and material costs. The present technology can also make systems more durable and reliable by removing the mode of failure due to adhesive delamination or fastener failure. Integrating strain sensors as a part of 3-dimensional printed objects also allows for measuring of internal strains at any internal location in the part. This can provide advantages over a separate strain sensor attached on the outside of the object, which only measures strain at the external surface where the sensor is attached.

[0013] 3-dimensional printing can be used to form a wide variety of parts, including parts that would be difficult or impossible to manufacture using traditional methods such as milling or molding. The present technology allows 3-dimensional printed strain sensors to be printed integrally in any 3-dimensional printed part. In some cases, the strain sensor can provide information to monitor the 3-dimensional printed part for stresses to which the part is subjected. In some examples, such a part can be manufactured to less stringent strength specifications than a non-instrumented part because the constant feedback from the strain sensor provides for detection of stresses that may compromise the integrity of the part. Using this feedback, the system in which the part is used can be adjusted to reduce stress on the part before the part fails. Thus, the present technology can reduce the part manufacturing cost without degrading performance of the system in which the part is used. The strain sensor can also improve accuracy of the strain measurement. Because the strain sensor is an integral component of the part being tested for strain, the strain sensor is always reliably exposed to the same forces exerted on the part.

[0014] In some examples of the present technology, 3-dimensional printed parts with integrated strain sensors can be formed using a process involving a powder bed of thermoplastic polymer particles, a conductive fusing ink, and a second fusing ink. In this process, a thin layer of polymer powder is spread on a bed to form a powder bed. A printing head, such as an inkjet print head, is then used to print fusing inks over portions of the powder bed corresponding to a thin layer of the three dimensional object to be formed. A conductive fusing ink can be printed in areas where a conductive resistor for the strain sensor is desired to be formed, and a second fusing ink can be printed in other areas. The bed is then exposed to a light source, e.g., typically the entire bed. The fusing inks absorb

more energy from the light than the unprinted powder. The absorbed light energy is converted to thermal energy, causing the printed portions of the powder to melt and coalesce. This forms a solid layer. After the first layer is formed, a new thin layer of polymer powder is spread over the powder bed and the process is
5 repeated to form additional layers until a complete 3-dimensional part is printed. Such 3-dimensional printing processes can achieve fast throughput with good accuracy.

[0015] With this description in mind, FIG. 1 shows an example of a strain sensor 100. The strain sensor, which can be a 3-dimensional printed strain
10 sensor, can include a resistor 110, a first electrical contact 120 at a first end of the resistor, and a second electrical contact 130 at a second end of the resistor. The resistor can be formed of a matrix of sintered elemental transition metal particles interlocked with a matrix of fused thermoplastic polymer particles. This composite material including the matrix of sintered elemental transition metal
15 particles and the matrix of fused thermoplastic polymer particles will be described in more detail below.

[0016] The present technology also extends to 3-dimensional printed parts having an integrated strain sensor. FIG. 2 shows an example of such a 3-
dimensional printed part 200. The part can include a part body 210 formed of
20 fused thermoplastic polymer particles. The integrated strain sensor can include a resistor 110, a first electrical contact 120 at a first end of the resistor, and a second electrical contact 130 at a second end of the resistor. As described above, the resistor can be formed of a matrix of sintered elemental transition metal particles interlocked with a matrix of fused thermoplastic polymer particles.
25 The matrix of fused thermoplastic polymer particles can be continuously fused to the fused thermoplastic polymer particles of the part body.

[0017] The conductive composite material making up the resistor is shown in more detail in FIGs. 3-4. As shown in FIG. 3, the resistor can be formed from thermoplastic polymer particles 330 and transition metal particles 320. In one
30 example of a method for making the resistor, a layer 300 of thermoplastic polymer particles can be spread in a powder bed 3-dimensional printer. A first portion 310 of the layer can be printed with a conductive ink containing a transition metal. A second portion 340 can be printed with a fusing ink that

includes a fusing agent capable of absorbing energy from electromagnetic radiation and converting the energy to heat. The layer of thermoplastic polymer particles can then be exposed to electromagnetic radiation to raise the temperature of the layer, causing the polymer particles to fuse together and the transition metal particles to sinter together. FIG. 4 shows the layer 400 after fusing. The polymer particles fuse together to form a matrix of fused thermoplastic polymer particles 430, and the transition metal particles sinter together to form a matrix of sintered transition metal particles 420. The matrix of fused thermoplastic polymer particles and the matrix of sintered transition metal particles are interlocked, forming a conductive composite. Additionally, the conductive composite is present only in the first region 410 where the conductive ink was printed, and not in the second region 440 where the other fusing ink was printed.

[0018] It should be noted that these figures are not necessarily drawn to scale, and the relative sizes of powder particles and transition metal particles can differ from those shown. For example, in many cases the transition metal particles can be much smaller than the powder particles, such as 2-3 orders of magnitude smaller.

[0019] It should also be noted that FIG. 4 shows only a 2-dimensional cross-section of the conductive composite. Although the sintered metal particles appear to be in isolated locations in the figure, the matrix of sintered metal particles can be a continuously connected matrix in three dimensions. Thus, the conductive composite can have good electrical conductivity through the matrix of sintered transition metal particles.

[0020] A variety of materials can be used to form the 3-dimensional printed strain sensors and parts having integrated strain sensors. In some examples, the materials can include a thermoplastic polymer powder, a conductive fusing ink, and a second fusing ink. The thermoplastic polymer powder can include powder particles with an average particle size from 20 μm to 100 μm . As used herein, "average" with respect to properties of particles refers to a number average unless otherwise specified. Accordingly, "average particle size" refers to a number average particle size. Additionally, "particle size" refers to the diameter of spherical particles, or to the longest dimension of non-spherical particles.

[0021] In certain examples, the polymer particles can have a variety of shapes, such as substantially spherical particles or irregularly-shaped particles. In some examples, the polymer powder can be capable of being formed into 3D printed parts with a resolution of 20 to 100 microns. As used herein, “resolution” refers to the size of the smallest feature that can be formed on a 3D printed part. The polymer powder can form layers from about 20 to about 100 microns thick, allowing the fused layers of the printed part to have roughly the same thickness. This can provide a resolution in the z-axis direction of about 20 to about 100 microns. The polymer powder can also have a sufficiently small particle size and sufficiently regular particle shape to provide about 20 to about 100 micron resolution along the x-axis and y-axis.

[0022] In some examples, the thermoplastic polymer powder can be colorless. For example, the polymer powder can have a white, translucent, or transparent appearance. When used with a colorless fusing ink, such polymer powders can provide a printed part that is white, translucent, or transparent. In other examples, the polymer powder can be colored for producing colored parts. In still other examples, when the polymer powder is white, translucent, or transparent, color can be imparted to the part by the fusing ink or another colored ink.

[0023] The thermoplastic polymer powder can have a melting or softening point from about 70°C to about 350°C. In further examples, the polymer can have a melting or softening point from about 150°C to about 200°C. A variety of thermoplastic polymers with melting points or softening points in these ranges can be used. For example, the polymer powder can be selected from the group consisting of nylon 6 powder, nylon 9 powder, nylon 11 powder, nylon 12 powder, nylon 66 powder, nylon 612 powder, polyethylene powder, thermoplastic polyurethane powder, polypropylene powder, polyester powder, polycarbonate powder, polyether ketone powder, polyacrylate powder, polystyrene powder, and mixtures thereof. In a specific example, the polymer powder can be nylon 12, which can have a melting point from about 175°C to about 200°C. In another specific example, the polymer powder can be thermoplastic polyurethane.

[0024] The thermoplastic polymer particles can also in some cases be blended with a filler. The filler can include inorganic particles such as alumina,

silica, or combinations thereof. When the thermoplastic polymer particles fuse together, the filler particles can become embedded in the polymer, forming a composite material. In some examples, the filler can include a free-flow agent, anti-caking agent, or the like. Such agents can prevent packing of the powder particles, coat the powder particles and smooth edges to reduce inter-particle friction, and/or absorb moisture. In some examples, a weight ratio of thermoplastic polymer particles to filler particles can be from 10:1 to 1:2 or from 5:1 to 1:1.

[0025] A conductive ink can be used to form portions of a 3-dimensional printed part that will act as a resistor in the strain sensor. The conductive fusing ink can include a transition metal. When the conductive fusing ink is printed onto a layer of the thermoplastic polymer powder, the conductive ink can penetrate into the spaces between powder particles. The layer can then be cured by exposing the layer to electromagnetic radiation. The conductive fusing ink can facilitate fusing of the powder particles by absorbing energy from the electromagnetic radiation and converting the energy to heat. This raises the temperature of the powder above the melting or softening point of the thermoplastic polymer. Additionally, during printing, curing, or both, the transition metal in the conductive ink can form a conductive transition metal matrix that becomes interlocked with the fused thermoplastic polymer particles.

[0026] In some examples, the transition metal in the conductive ink can be in the form of elemental transition metal particles. The elemental transition metal particles can include, for example, silver particles, copper particles, gold particles, platinum particles, palladium particles, chromium particles, nickel particles, zinc particles, or combinations thereof. The particles can also include alloys of more than one transition metal, such as Au—Ag, Ag—Cu, Ag—Ni, Au—Cu, Au—Ni, Au—Ag—Cu, or Au—Ag—Pd.

[0027] In certain examples, other non-transition metals can be included in addition to the transition metal. The non-transition metals can include lead, tin, bismuth, indium, gallium, and others. In some examples, soldering alloys can be included. The soldering alloys can include alloys of lead, tin, bismuth, indium, zinc, gallium, silver, copper, in various combinations. In certain examples, such soldering alloys can be printed in locations that are to be used as soldering

connections for printed electrical components. The soldering alloys can be formulated to have low melting temperatures useful for soldering, such as less than 230 °C.

5 **[0028]** In further examples, the elemental transition metal particles can be nanoparticles having an average particle size from 10 nm to 200 nm. In more specific examples, the elemental transition metal particles can have an average particle size from 30 nm to 70 nm.

10 **[0029]** As metal particles are reduced in size, the temperature at which the particles are capable of being sintered can also be reduced. Therefore, using elemental transition metal nanoparticles in the conductive fusing ink can allow the particles to sinter and form a conductive matrix of sintered nanoparticles at relatively low temperatures. For example, the elemental transition metal particles in the conductive fusing ink can be capable of being sintered at or below the temperature reached during curing in the 3-dimensional printing process. In a further example, the thermoplastic polymer powder bed can be heated to a preheat temperature during the printing process, and the elemental transition metal particles can be capable of being sintered at or below the preheat temperature. In still further examples, the elemental transition metal particles can be capable of being sintered at a temperature from 20 °C to 350 °C. As used herein, the temperature at which the elemental transition metal particles are capable of being sintered refers to the lowest temperature at which the particles will become sintered together, forming a conductive matrix of sintered particles. It is understood that temperatures above this lowest temperature will also cause the particles to become sintered.

25 **[0030]** In additional examples of the conductive fusing ink, the transition metal can be in the form of elemental transition metal particles that are stabilized by a dispersing agent at surfaces of the particles. The dispersing agent can include ligands that passivate the surface of the particles. Suitable ligands can include a moiety that binds to the transition metal. Examples of such moieties can include sulfonic acid, phosphonic acid, carboxylic acid, dithiocarboxylic acid, phosphonate, sulfonate, thiol, carboxylate, dithiocarboxylate, amine, and others. In some cases, the dispersing agent can contain an alkyl group having from 3-20 carbon atoms, with one of the above moieties at an end of the alkyl chain. In

certain examples, the dispersing agent can be an alkylamine, alkylthiol, or combinations thereof. In further examples, the dispersing agent can be a polymeric dispersing agent, such as polyvinylpyrrolidone (PVP), polyvinylalcohol (PVA), polymethylvinylether, poly(acrylic acid) (PAA), nonionic surfactants, polymeric chelating agents, and others. The dispersing agent can bind to the surfaces of the elemental transition metal particles through chemical and/or physical attachment. Chemical bonding can include a covalent bond, hydrogen bond, coordination complex bond, ionic bond, or combinations thereof. Physical attachment can include attachment through van der Waal's forces, dipole-dipole interactions, or a combination thereof.

[0031] In further examples, the conductive fusing ink can include a transition metal in the form of a metal salt or metal oxide. Under certain conditions, a transition metal salt or metal oxide in the conductive ink can form elemental transition metal particles *in situ* after being printed onto the thermoplastic polymer powder bed. The elemental transition metal particles thus formed can then be sintered together to form a conductive matrix. In some examples, a reducing agent can be reacted with the metal salt or metal oxide to produce elemental metal particles. In one example, a reducing agent can be underprinted onto the powder bed before the conductive fusing ink. In another example, a reducing agent can be overprinted over the conductive fusing ink. In either case, the reducing agent can be reacted with the metal salt or metal oxide to form elemental metal particles before the thermoplastic polymer particle layer is cured. Suitable reducing agents can include, for example, glucose, fructose, maltose, maltodextrin, trisodium citrate, ascorbic acid, sodium borohydride, ethylene glycol, 1,5-pentanediol, 1,2-propylene glycol, and others.

[0032] The concentration of transition metal in the conductive fusing ink can vary. However, higher transition metal concentrations can tend to provide better conductivity due to a larger amount of conductive material being deposited on the powder bed. In some examples, the conductive fusing ink can contain from about 5 wt% to about 50 wt% of the transition metal, with respect to the entire weight of the conductive fusing ink. In further examples, the conductive fusing ink can contain from about 10 wt% to about 30 wt% of the transition metal, with respect to the entire weight of the conductive fusing ink.

[0033] In some examples of the present technology, a pretreat ink can be used with the conductive fusing ink. The pretreat ink can include a halogen salt, such as sodium chloride or potassium chloride, for example. The halogen salt can react with dispersing agents at the surfaces of transition metal particles to
5 remove the dispersing agents from the particles. This can increase the sintering between the metal particles and improve the conductivity of the matrix formed of the sintered particles. The pretreat ink can be dispensed onto the powder bed before the conductive fusing ink. When the conductive fusing ink is printed over the pretreat ink, the transition metal particles can come into contact with the
10 halogen salt in the pretreat ink. In alternate examples, the polymer powder can be pretreated with a halogen salt before being used in the 3-dimensional printing system. When the conductive fusing ink is printed onto the powder bed, the transition metal particles in the conductive fusing ink can come into contact with the halogen salt already present on the powder.

[0034] A second fusing ink can also be incorporated in the materials used to make 3-dimensional printed strain sensors and parts having integrated strain sensors. In some examples, the second fusing ink can be devoid or substantially devoid of the transition metal contained in the conductive fusing ink. Thus, the second fusing ink can provide a lower conductivity than the conductive fusing ink
20 when printed on the thermoplastic polymer powder. However, in some examples the second fusing ink can include metal particles that provide a lower conductivity than the transition metal in the conductive fusing ink. For example, the second fusing ink can include metal particles with passivated surfaces that do not sinter together to form a conductive matrix.

[0035] The second fusing ink can contain another fusing agent that is capable of absorbing electromagnetic radiation to produce heat. The fusing agent can be colored or colorless. In various examples, the fusing agent can be carbon black, near-infrared absorbing dyes, near-infrared absorbing pigments, tungsten bronzes, molybdenum bronzes, metal nanoparticles, or combinations thereof.
25 Examples of near-infrared absorbing dyes include aminium dyes,
30 tetraaryldiamine dyes, cyanine dyes, phthalocyanine dyes, dithiolene dyes, and others. In further examples, the fusing agent can be a near-infrared absorbing conjugated polymer such as poly(3,4-ethylenedioxythiophene)-

poly(styrenesulfonate) (PEDOT:PSS), a polythiophene, poly(p-phenylene sulfide), a polyaniline, a poly(pyrrole), a poly(acetylene), poly(p-phenylene vinylene), polyparaphenylene, or combinations thereof. As used herein, “conjugated” refers to alternating double and single bonds between atoms in a molecule. Thus, “conjugated polymer” refers to a polymer that has a backbone with alternating double and single bonds. In many cases, the fusing agent can have a peak absorption wavelength in the range of 800 nm to 1400 nm.

[0036] The amount of fusing agent in the second fusing ink can vary depending on the type of fusing agent. In some examples, the concentration of fusing agent in the second fusing ink can be from 0.1 wt% to 20 wt%. In one example, the concentration of fusing agent in the second fusing ink can be from 0.1 wt% to 15 wt%. In another example, the concentration can be from 0.1 wt% to 8 wt%. In yet another example, the concentration can be from 0.5 wt% to 2 wt%. In a particular example, the concentration can be from 0.5 wt% to 1.2 wt%.

[0037] In some examples, the fusing ink can have a black or gray color due to the use of carbon black as the fusing agent. However, in other examples the fusing ink can be colorless or nearly colorless. The concentration of the fusing agent can be adjusted to provide a fusing ink in which the visible color of the fusing ink is not substantially altered by the fusing agent. Although some of the above described fusing agents have low absorbance in the visible light range, the absorbance is usually greater than zero. Therefore, the fusing agents can typically absorb some visible light, but their color in the visible spectrum can be minimal enough that it does not substantially impact the ink’s ability to take on another color when a colorant is added (unlike carbon black which dominates the ink’s color with gray or black tones). The fusing agents in concentrated form can have a visible color, but the concentration of the fusing agents in the fusing ink can be adjusted so that the fusing agents are not present in such high amounts that they alter the visible color of the fusing ink. For example, a fusing agent with a very low absorbance of visible light wavelengths can be included in greater concentrations compared to a fusing agent with a relatively higher absorbance of visible light. These concentrations can be adjusted based on a specific application with some experimentation.

[0038] In further examples, the concentration of the fusing agent can be

high enough that the fusing agent impacts the color of the fusing ink, but low enough that when the ink is printed on the thermoplastic polymer powder, the fusing agent does not impact the color of the powder. The concentration of the fusing agent can be balanced with the amount of fusing ink that is to be printed
5 on the polymer powder so that the total amount of fusing agent that is printed onto the polymer powder is low enough that the visible color of the polymer powder is not impacted. In one example, the fusing agent can have a concentration in the fusing ink such that after the fusing ink is printed onto the polymer powder, the amount of fusing agent in the polymer powder is from
10 0.0003 wt% to 5 wt% with respect to the weight of the polymer powder.

[0039] The fusing agent can have a temperature boosting capacity sufficient to increase the temperature of the polymer powder above the melting or softening point of the polymer powder. As used herein, "temperature boosting capacity" refers to the ability of a fusing agent to convert near-infrared light
15 energy into thermal energy to increase the temperature of the printed polymer powder over and above the temperature of the unprinted portion of the polymer powder. Typically, the polymer powder particles can be fused together when the temperature increases to the melting or softening temperature of the polymer. As used herein, "melting point" refers to the temperature at which a polymer
20 transitions from a crystalline phase to a pliable, amorphous phase. Some polymers do not have a melting point, but rather have a range of temperatures over which the polymers soften. This range can be segregated into a lower softening range, a middle softening range and an upper softening range. In the lower and middle softening ranges, the particles can coalesce to form a part while
25 the remaining polymer powder remains loose. If the upper softening range is used, the whole powder bed can become a cake. The "softening point," as used herein, refers to the temperature at which the polymer particles coalesce while the remaining powder remains separate and loose. When the fusing ink is printed on a portion of the polymer powder, the fusing agent can heat the printed portion
30 to a temperature at or above the melting or softening point, while the unprinted portions of the polymer powder remain below the melting or softening point. This allows the formation of a solid 3D printed part, while the loose powder can be easily separated from the finished printed part.

[0040] Although melting point and softening point are often described herein as the temperatures for coalescing the polymer powder, in some cases the polymer particles can coalesce together at temperatures slightly below the melting point or softening point. Therefore, as used herein “melting point” and “softening point” can include temperatures slightly lower, such as up to about 5 20°C lower, than the actual melting point or softening point.

[0041] In one example, the fusing agent can have a temperature boosting capacity from about 10°C to about 70°C for a polymer with a melting or softening point from about 100°C to about 350°C. If the powder bed is at a temperature 10 within about 10°C to about 70°C of the melting or softening point, then such a fusing agent can boost the temperature of the printed powder up to the melting or softening point, while the unprinted powder remains at a lower temperature. In some examples, the powder bed can be preheated to a temperature from about 10°C to about 70°C lower than the melting or softening point of the polymer. The 15 fusing ink can then be printed onto the powder and the powder bed can be irradiated with a near-infrared light to coalesce the printed portion of the powder.

[0042] In some examples of the present technology, the conductive fusing ink and the second fusing ink can be balanced so that thermoplastic polymer powder that is printed with the conductive fusing ink and the second fusing ink 20 reach nearly the same temperature when exposed to light during curing. The type and amount of fusing agent in the second fusing ink can be selected to match the temperature boosting capacity of the transition metal in the conductive fusing ink. The type and amount of transition metal in the conductive fusing ink can also be adjusted to match the temperature boosting capacity of the fusing agent in the 25 second fusing ink. Additionally, in some examples the conductive fusing ink can contain another fusing agent other than the transition metal. In certain examples, the conductive fusing ink and the second fusing ink can raise the temperature of the thermoplastic polymer powder to temperatures within 30 °C, within 20 °C, or within 10 °C of each other during curing.

[0043] In further examples, colored inks can also be used for adding color 30 to the thermoplastic polymer powder. This can allow for printing of full-color 3-dimensional parts. In one example, the cyan, magenta, yellow, and black inks can be used in addition to the conductive fusing ink, second fusing ink, and

pretreat ink if present.

[0044] Each of the conductive fusing ink, pretreat ink, second fusing ink, and additional colored inks can be formulated for use in an ink jet printer. The transition metal and fusing agents can be stable in an ink jet ink vehicle and the inks can provide good ink jetting performance. In some examples, the transition metal and fusing agents can be water-soluble, water-dispersible, organic-soluble, or organic-dispersible. The transition metal and fusing agents can also be compatible with the thermoplastic polymer powder so that jetting the inks onto the polymer powder provides adequate coverage and interfiltration of the transition metal and fusing agents into the powder.

[0045] Any of the above described inks can also include a pigment or dye colorant that imparts a visible color to the inks. In some examples, the colorant can be present in an amount from 0.5 wt% to 10 wt% in the inks. In one example, the colorant can be present in an amount from 1 wt% to 5 wt%. In another example, the colorant can be present in an amount from 5 wt% to 10 wt%. However, the colorant is optional and in some examples the inks can include no additional colorant. These inks can be used to print 3D parts that retain the natural color of the polymer powder. Additionally, the inks can include a white pigment such as titanium dioxide that can also impart a white color to the final printed part. Other inorganic pigments such as alumina or zinc oxide can also be used.

[0046] In some examples, the colorant can be a dye. The dye may be nonionic, cationic, anionic, or a mixture of nonionic, cationic, and/or anionic dyes. Specific examples of dyes that may be used include, but are not limited to, Sulforhodamine B, Acid Blue 113, Acid Blue 29, Acid Red 4, Rose Bengal, Acid Yellow 17, Acid Yellow 29, Acid Yellow 42, Acridine Yellow G, Acid Yellow 23, Acid Blue 9, Nitro Blue Tetrazolium Chloride Monohydrate or Nitro BT, Rhodamine 6G, Rhodamine 123, Rhodamine B, Rhodamine B Isocyanate, Safranin O, Azure B, and Azure B Eosinate, which are available from Sigma-Aldrich Chemical Company (St. Louis, Mo.). Examples of anionic, water-soluble dyes include, but are not limited to, Direct Yellow 132, Direct Blue 199, Magenta 377 (available from Ilford AG, Switzerland), alone or together with Acid Red 52. Examples of water-insoluble dyes include azo, xanthene, methine, polymethine,

and anthraquinone dyes. Specific examples of water-insoluble dyes include Orasol® Blue GN, Orasol® Pink, and Orasol® Yellow dyes available from Ciba-Geigy Corp. Black dyes may include, but are not limited to, Direct Black 154, Direct Black 168, Fast Black 2, Direct Black 171, Direct Black 19, Acid Black 1, Acid Black 191, Mobay Black SP, and Acid Black 2.

[0047] In other examples, the colorant can be a pigment. The pigment can be self-dispersed with a polymer, oligomer, or small molecule; or can be dispersed with a separate dispersant. Suitable pigments include, but are not limited to, the following pigments available from BASF: Paliogen® Orange, Heliogen® Blue L 6901F, Heliogen® Blue NBD 7010, Heliogen® Blue K 7090, Heliogen® Blue L 7101F, Paliogen® Blue L 6470, Heliogen® Green K 8683, and Heliogen® Green L 9140. The following black pigments are available from Cabot: Monarch® 1400, Monarch® 1300, Monarch® 1100, Monarch® 1000, Monarch® 900, Monarch® 880, Monarch® 800, and Monarch® 700. The following pigments are available from CIBA: Chromophthal® Yellow 3G, Chromophthal® Yellow GR, Chromophthal® Yellow 8G, Igrazin® Yellow 5GT, Igralite® Rubine 4BL, Monastral® Magenta, Monastral® Scarlet, Monastral® Violet R, Monastral® Red B, and Monastral® Violet Maroon B. The following pigments are available from Degussa: Printex® U, Printex® V, Printex® 140U, Printex® 140V, Color Black FW 200, Color Black FW 2, Color Black FW 2V, Color Black FW 1, Color Black FW 18, Color Black S 160, Color Black S 170, Special Black 6, Special Black 5, Special Black 4A, and Special Black 4. The following pigment is available from DuPont: Tipure® R-101. The following pigments are available from Heubach: Dalamar® Yellow YT-858-D and Heucophthal Blue G XBT-583D. The following pigments are available from Clariant: Permanent Yellow GR, Permanent Yellow G, Permanent Yellow DHG, Permanent Yellow NCG-71, Permanent Yellow GG, Hansa Yellow RA, Hansa Brilliant Yellow 5GX-02, Hansa Yellow-X, Novoperm® Yellow HR, Novoperm® Yellow FGL, Hansa Brilliant Yellow 10GX, Permanent Yellow G3R-01, Hostaperm® Yellow H4G, Hostaperm® Yellow H3G, Hostaperm® Orange GR, Hostaperm® Scarlet GO, and Permanent Rubine F6B. The following pigments are available from Mobay: Quindo® Magenta, Indofast® Brilliant Scarlet, Quindo® Red R6700, Quindo® Red R6713, and Indofast® Violet. The following

pigments are available from Sun Chemical: L74-1357 Yellow, L75-1331 Yellow, and L75-2577 Yellow. The following pigments are available from Columbian: Raven® 7000, Raven® 5750, Raven® 5250, Raven® 5000, and Raven® 3500. The following pigment is available from Sun Chemical: LHD9303 Black. Any
5 other pigment and/or dye can be used that is useful in modifying the color of the above described inks and/or ultimately, the printed part.

[0048] The colorant can be included in the conductive fusing ink and/or the second fusing ink to impart color to the printed object when the fusing inks are jetted onto the powder bed. Optionally, a set of differently colored fusing inks can
10 be used to print multiple colors. For example, a set of fusing inks including any combination of cyan, magenta, yellow (and/or any other colors), colorless, white, and/or black fusing inks can be used to print objects in full color. Alternatively or additionally, a colorless fusing ink can be used in conjunction with a set of colored, non-fusing inks to impart color. In some examples, a colorless fusing ink
15 can be used to coalesce the polymer powder and a separate set of colored or black or white inks not containing a fusing agent can be used to impart color.

[0049] The components of the above described inks can be selected to give the inks good ink jetting performance and the ability to color the polymer powder with good optical density. Besides the transition metals, fusing agents,
20 colorants and other ingredients described above, the inks can also include a liquid vehicle. In some examples, the liquid vehicle formulation can include water and one or more co-solvents present in total at from 1 wt% to 50 wt%, depending on the jetting architecture. Further, one or more non-ionic, cationic, and/or anionic surfactant can optionally be present, ranging from 0.01 wt% to 20 wt%. In one
25 example, the surfactant can be present in an amount from 5 wt% to 20 wt%. The liquid vehicle can also include dispersants in an amount from 5 wt% to 20 wt%. The balance of the formulation can be purified water, or other vehicle components such as biocides, viscosity modifiers, materials for pH adjustment, sequestering agents, preservatives, and the like. In one example, the liquid
30 vehicle can be predominantly water. In some examples, a water-dispersible or water-soluble fusing agent can be used with an aqueous vehicle. Because the fusing agent is dispersible or soluble in water, an organic co-solvent is not necessary to solubilize the fusing agent. Therefore, in some examples the inks

can be substantially free of organic solvent. However, in other examples a co-solvent can be used to help disperse other dyes or pigments, or improve the jetting properties of the ink. In still further examples, a non-aqueous vehicle can be used with an organic-soluble or organic-dispersible fusing agent.

5 **[0050]** In certain examples, a high boiling point co-solvent can be included in the inks. The high boiling point co-solvent can be an organic co-solvent that boils at a temperature higher than the temperature of the powder bed during printing. In some examples, the high boiling point co-solvent can have a boiling point above 250 °C. In still further examples, the high boiling point co-solvent can
10 be present in the ink at a concentration from about 1 wt% to about 4 wt%.

[0051] Classes of co-solvents that can be used can include organic co-solvents including aliphatic alcohols, aromatic alcohols, diols, glycol ethers, polyglycol ethers, caprolactams, formamides, acetamides, and long chain alcohols. Examples of such compounds include primary aliphatic alcohols,
15 secondary aliphatic alcohols, 1,2-alcohols, 1,3-alcohols, 1,5-alcohols, ethylene glycol alkyl ethers, propylene glycol alkyl ethers, higher homologs (C₆-C₁₂) of polyethylene glycol alkyl ethers, N-alkyl caprolactams, unsubstituted caprolactams, both substituted and unsubstituted formamides, both substituted and unsubstituted acetamides, and the like. Specific examples of solvents that
20 can be used include, but are not limited to, 2-pyrrolidinone, N-methylpyrrolidone, 2-hydroxyethyl-2-pyrrolidone, 2-methyl-1,3-propanediol, tetraethylene glycol, 1,6-hexanediol, 1,5-hexanediol and 1,5-pentanediol.

[0052] One or more surfactants can also be used, such as alkyl polyethylene oxides, alkyl phenyl polyethylene oxides, polyethylene oxide block
25 copolymers, acetylenic polyethylene oxides, polyethylene oxide (di)esters, polyethylene oxide amines, protonated polyethylene oxide amines, protonated polyethylene oxide amides, dimethicone copolyols, substituted amine oxides, and the like. The amount of surfactant added to the formulation of this disclosure may range from 0.01 wt% to 20 wt%. Suitable surfactants can include, but are not
30 limited to, liponic esters such as Tergitol™ 15-S-12, Tergitol™ 15-S-7 available from Dow Chemical Company, LEG-1 and LEG-7; Triton™ X-100; Triton™ X-405 available from Dow Chemical Company ; and sodium dodecylsulfate.

[0053] Consistent with the formulation of this disclosure, various other

additives can be employed to optimize the properties of the ink compositions for specific applications. Examples of these additives are those added to inhibit the growth of harmful microorganisms. These additives may be biocides, fungicides, and other microbial agents, which are routinely used in ink formulations.

5 Examples of suitable microbial agents include, but are not limited to, NUOSEPT® (Nudex, Inc.), UCARCIDE™ (Union carbide Corp.), VANCIDE® (R.T. Vanderbilt Co.), PROXEL® (ICI America), and combinations thereof.

[0054] Sequestering agents, such as EDTA (ethylene diamine tetra acetic acid), may be included to eliminate the deleterious effects of heavy metal
 10 impurities, and buffer solutions may be used to control the pH of the ink. From 0.01 wt% to 2 wt%, for example, can be used. Viscosity modifiers and buffers may also be present, as well as other additives to modify properties of the ink as desired. Such additives can be present at from 0.01 wt% to 20 wt%.

[0055] In one example, the liquid vehicle can include the components and
 15 amounts as shown in Table 1:

TABLE 1

Ingredients	Wt (%)
2-Pyrrolidinone	50 - 75
2-Methyl-1,3-Propanediol	5 - 12
Tetraethylene glycol	5 - 12
LEG-1	5 - 10
Surfynol® CT151 surfactant from Air Products and Chemicals, Inc.	0.2 – 1.2
Zonyl® FSO fluorosurfactant from DuPont	0.01 - 1
SMA1440H	1 - 5
Tris base	0.1 - 1

20 **[0056]** In another example, the liquid vehicle can include the components and amounts as shown in Table 2:

TABLE 2

Ink Components	Wt (%)
2-Pyrrolidinone	50 – 99.9
Crodafos N3™ surfactant from Croda	0.1 - 5

[0057] In yet another example, the liquid vehicle can include the components and amounts as shown in Table 3:

5

TABLE 3

Component	Wt %
2-methyl-1,3-propanediol	10 - 40
Crodafos N3™ surfactant from Croda	0.1 - 5
Tergitol™ 15-S-12 surfactant from Dow Chemical Company	0.1 - 3
Zonyl® FSO-100 fluorosurfactant from DuPont	0.5 - 5
Proxel™ GXL (20% as is) biocide from Lonza	0.1 - 1

[0058] In still another example, the liquid vehicle can include the components and amounts as shown in Table 4:

10

TABLE 4

Component	Wt %
2-Hydroxyethyl-2-Pyrrolidone	5 - 20
Dantocol™ DHE bonding agent from Lonza	30 – 80
LEG	1 - 20
Crodafos N3™ surfactant from Croda	1 - 20
Surfynol® SEF (75% as is) surfactant from Air Products and Chemicals, Inc.	1 - 10
Kordek™ MLX (10% as is) biocide from Dow Chemical Company	0.1 - 5
Proxel™ GXL (20% as is) biocide from Lonza	0.1 - 5

[0059] In a further example, the liquid vehicle can include the components and amounts as shown in Table 5:

TABLE 5

Ink vehicle components	Wt %
Tripropylene glycol	20 - 60
1-(2-Hydroxyethyl)-2-imidazolidinone	20 - 40
LEG-1	0.5 - 5
Crodafos N3™ surfactant from Croda	1 - 6
Tergitol™ 15-S-7 surfactant from Dow Chemical Company	1 - 6
Zonyl® FSO fluorosurfactant from DuPont	0.1 – 1.2
Proxel™ GXL biocide from Lonza	0.1 – 1.2

5 [0060] In yet another example, the liquid vehicle can include the components and amounts shown in Table 6:

TABLE 6

Ink vehicle components	Wt%
Ethylene glycol	65 – 96.9
Ethanol	3 - 20
Isopropyl alcohol	0.1 - 15

10 [0061] It is noted the liquid vehicle formulations of Tables 1 to 6 are provided by example only and other formulations with similar properties can likewise be formulated in accordance with the present technology

[0062] The present technology also extends to methods of making 3-dimensional printed parts having integrated strain sensors. The methods can use any of the materials described above. FIG. 5 is a flowchart of an exemplary method 500 of making a 3-dimensional printed part having an integrated strain sensor. The method includes dispensing a conductive fusing ink onto a first area of a layer of thermoplastic polymer particles, wherein the conductive fusing ink includes a transition metal 510; dispensing a second fusing ink onto a second area of the layer of thermoplastic polymer particles, wherein the second fusing

15

20

ink includes a fusing agent capable of absorbing electromagnetic radiation to produce heat 520; and fusing the first and second areas with electromagnetic radiation to form a resistor in the first area and a part body in the second area, wherein the resistor includes a matrix of sintered transition metal particles
5 interlocked with a matrix of fused thermoplastic polymer particles, and the part body includes fused thermoplastic polymer particles 530.

[0063] In further examples, methods of making 3-dimensional printed parts having integrated strain sensors can include dispensing additional inks onto the thermoplastic polymer particles. For example, a pretreat ink can be dispensed
10 onto the polymer particles before dispensing the conductive fusing ink. The pretreat ink can include a halogen salt such as sodium chloride or potassium chloride to remove dispersing agents from the transition metal particles in the conductive fusing ink. Colored inks can also be dispensed onto the polymer particles to provide visible colors to the printed part.

15 **[0064]** In some examples, the fusing inks and other inks can be dispensed by ink jetting. This can be performed by a thermal ink jet printing system or a piezo ink jet printing system. Any other suitable method of dispensing the inks onto the polymer particles can also be used.

[0065] In additional examples, the methods described herein can be
20 performed using a powder bed 3-dimensional printing system. In one example, the bed of the thermoplastic polymer particles can be formed by introducing polymer powder from a polymer powder supply and rolling the powder in a thin layer using a roller. The conductive fusing ink and second fusing ink can be jetted using ink jet print heads. The amount of conductive ink printed can be calibrated
25 based on the concentration of transition metal in the ink, the temperature boosting capacity of the transition metal, the desired conductivity of the resulting conductive composite material to be printed, among other factors. Similarly, the amount of the second fusing ink printed can be calibrated based the
concentration of fusing agent, temperature boosting capacity of the fusing agent,
30 and other factors. In some examples, the amount of fusing ink printed can be sufficient to contact a fusing agent with the entire layer of polymer powder. For example, if each layer of polymer powder is 100 microns thick, then the fusing ink can penetrate at least 100 microns into the polymer powder. Thus the fusing

agents can heat the polymer powder throughout the entire layer so that the layer can coalesce and bond to the layer below. After forming a solid layer, a new layer of loose powder can be formed, either by lowering the powder bed or by raising the height of the roller and rolling a new layer of powder.

5 **[0066]** The entire powder bed can be preheated to a temperature below the melting or softening point of the polymer powder. In one example, the preheat temperature can be from about 10°C to about 30°C below the melting or softening point. In another example, the preheat temperature can be within 50°C of the melting or softening point. In a particular example, the preheat temperature
10 can be from about 160°C to about 170°C and the polymer powder can be nylon 12 powder. In another example, the preheat temperature can be about 90°C to about 100°C and the polymer powder can be thermoplastic polyurethane. Preheating can be accomplished with one or more lamps, an oven, a heated support bed, or other types of heaters. In some examples, the entire powder bed
15 can be heated to a substantially uniform temperature.

[0067] The powder bed can be irradiated with a fusing lamp. Suitable fusing lamps for use in the methods described herein can include commercially available infrared lamps and halogen lamps. The fusing lamp can be a stationary lamp or a moving lamp. For example, the lamp can be mounted on a track to
20 move horizontally across the powder bed. Such a fusing lamp can make multiple passes over the bed depending on the amount of exposure needed to coalesce each printed layer. The fusing lamp can be configured to irradiate the entire powder bed with a substantially uniform amount of energy. This can selectively coalesce the printed portions with fusing inks leaving the unprinted portions of the
25 polymer powder below the melting or softening point.

[0068] In one example, the fusing lamp can be matched with the fusing agents in the fusing inks so that the fusing lamp emits wavelengths of light that match the peak absorption wavelengths of the fusing agents. A fusing agent with a narrow peak at a particular near-infrared wavelength can be used with a fusing
30 lamp that emits a narrow range of wavelengths at approximately the peak wavelength of the fusing agent. Similarly, a fusing agent that absorbs a broad range of near-infrared wavelengths can be used with a fusing lamp that emits a broad range of wavelengths. Matching the fusing agent and the fusing lamp in

this way can increase the efficiency of coalescing the polymer particles with the fusing agent printed thereon, while the unprinted polymer particles do not absorb as much light and remain at a lower temperature.

[0069] Depending on the amount of fusing agent present in the polymer powder, the absorbance of the fusing agent, the preheat temperature, and the melting or softening point of the polymer, an appropriate amount of irradiation can be supplied from the fusing lamp. In some examples, the fusing lamp can irradiate each layer from about 0.5 to about 10 seconds per pass.

[0070] In further examples, methods of making 3-dimensional printed parts having integrated strain sensors can include tuning the resistance of the 3-dimensional printed resistor to a desired range. As explained above, the resistor can have the form of a conductive composite with a matrix of fused thermoplastic polymer particles interlocked with a matrix of sintered transition metal particles. The resistance of the conductive composite can be tuned in a variety of ways. For example, the resistance can be affected by the type of transition metal in the conductive fusing ink, the concentration of the transition metal in the conductive fusing ink, the amount of conductive fusing ink dispensed onto the powder bed, the cross section and length of the resistor, and so on. When the conductive fusing ink is dispensed by ink jetting, the amount of conductive fusing ink dispensed can be adjusted by changing print speed, drop weight, number of slots from which the ink is fired in the ink jet printer, and number of passes printed per powder layer. In certain examples, a conductive composite element can have a resistance from 1 ohm to 5 Mega ohms.

[0071] Sufficient conductivity can be achieved by dispensing a sufficient amount of the transition metal onto the powder bed. In some examples, a sufficient mass of the transition metal per volume of the conductive composite can be used to achieve conductivity. For example, the mass of transition metal per volume of conductive composite can be greater than 1 mg/cm³, greater than 10 mg/cm³, greater than 50 mg/cm³, or greater than 100 mg/cm³. In a particular example, the mass of transition metal per volume of the conductive composite can be greater than 140 mg/cm³. In further examples, the mass of transition metal per volume of conductive composite can be from 1 mg/cm³ to 1000 mg/cm³, from 10 mg/cm³ to 1000 mg/cm³, from 50 mg/cm³ to 500 mg/cm³, or

from 100 mg/cm³ to 500 mg/cm³.

[0072] In certain examples, a smaller amount of transition metal can be dispensed to achieve surface conductivity, and a larger amount of transition metal can be applied to achieve bulk conductivity in the conductive composite.

5 Thus, in some examples a smaller amount of conductive fusing ink can be printed on a single layer of polymer particles to form a resistor that has conductivity across the surface of the layer, i.e., in the x-y plane. In some examples, resistors with conductivity in the x-y plane can be formed with a mass of transition metal per volume of conductive composite that is greater than 1 mg/cm³ or greater than
10 10 mg/cm³. In further examples, such resistors can be formed with a mass of transition metal per volume of conductive composite from 1 mg/cm³ to 1000 mg/cm³, 10 mg/cm³ to 500 mg/cm³, or 30 mg/cm³ to 200 mg/cm³. However, such resistors may not have sufficient conductivity in the z-axis direction, or in other words, through the bulk of the layer. As used herein, the “z-axis” refers to the axis
15 orthogonal to the x-y plane. For example, in 3-dimensional printing methods that use a powder bed that lowers after each layer is printed, the powder bed is lowered in the z-axis direction.

[0073] In some examples, a resistor that is conductive only in the x-y plane can be sufficient. This is the case when the resistor is formed parallel to the
20 layers of the 3-dimensional printed part. However, methods according to the present technology can also be used to print resistors that are conductive in the z-axis direction. By dispensing a larger amount of conductive fusing ink onto the layer of polymer particles, the conductive ink can penetrate through the layer and conductivity between layers in the z-axis direction can be achieved. In some
25 examples, resistors that are conductive in the z-axis direction can be formed with a mass of transition metal per volume of conductive composite that is greater than 50 mg/cm³ or greater than 100 mg/cm³. In further examples, such resistors can be formed with a mass of transition metal per volume of conductive composite from 50 mg/cm³ to 1000 mg/cm³, 100 mg/cm³ to 1000 mg/cm³, or 140
30 mg/cm³ to 500 mg/cm³.

[0074] In some examples, the amount of transition metal dispensed onto the powder bed can be adjusted by printing the conductive fusing ink in multiple passes. In one example, a single pass of an inkjet print head can be sufficient to

dispense enough transition metal to achieve surface conductivity. However, in some cases, a single pass is not sufficient to achieve conductivity in the z-axis direction. Additional passes can be applied to increase the amount of transition metal in the transition metal composite. A sufficient number of passes can be used to achieve conductivity in the z-axis direction. In one example, three or more passes can be used to form a conductive composite with conductivity in the z-axis direction. In further examples, the amount of transition metal dispensed can be adjusted by adjusting the drop weight of the inkjet printhead either through resistor design or by changing firing parameters. Thus, with a greater drop weight, a greater amount of the conductive fusing ink can be printed with each drop fired. However, in some cases jetting too large an amount of ink in a single pass can lead to lower print quality because of ink spreading. Therefore, in some examples multiple passes can be used to print more of the conductive fusing ink with better print quality

[0075] In a particular example, a 3-dimensional printed part can be formed as follows. An inkjet printer can be used to print a first pass including printing a conductive fusing ink onto a first portion of the powder bed and printing a second fusing ink onto a second portion of the powder bed. A curing pass can then be performed by passing a fusing lamp over the powder bed to fuse the polymer particles and sinter transition metal particles in the conductive curing ink. Then, one or more additional passes can be performed of printing the conductive fusing ink onto the first portion of the powder bed to increase the amount of transition metal. Each pass of printing the conductive fusing ink can be followed by a curing pass with the fusing lamp. The number of passes used can depend on the desired conductivity, the contone level of the printing passes (referring to the density of ink per area deposited on each pass), the type of transition metal in the conductive fusing ink, concentration of transition metal in the conductive fusing ink, thickness of the layer of polymer powder being printed, and so on.

[0076] Accordingly, the methods of the present technology can be used to make 3-dimensional printed parts with integrated strain sensors that are oriented in any direction. As explained above, a resistor can be formed in the x-y plane with respect to the layers of the 3-dimensional printed part using a relatively smaller amount of conductive fusing ink, while resistors oriented in the z-axis

direction can be formed by using a relatively greater amount of conductive fusing ink on each layer. In one example, the resistor can be oriented at least partially in the z-axis direction with respect to the layers of the 3-dimensional printed part. As used herein, "at least partially in the z-axis direction" refers to any direction that has at least a non-zero component on the z-axis. Therefore, resistors can be formed parallel to the z-axis or diagonal to the z-axis using the methods described herein.

[0077] The 3-dimensional printing methods described herein can be used to manufacture a wide variety of complex part shapes. The resistors printed as integrated strain sensors can similarly have a wide variety of shapes. In some examples, the resistor can have a serpentine shape with multiple turns along the length of the resistor. In some cases, increasing the length of the resistor can increase the overall resistance, while increasing the number of turns in the resistor can improve the sensitivity of the strain sensor. Other resistor shapes can also be used.

[0078] 3-dimensional printed parts can also be made with multiple integrated resistors. For example, multiple resistors can be included to measure strain on multiple portions of the part. In another example, two resistors can be placed on opposite sides of a part under flexing stress so that one resistor can be compressed and the other resistor can be extended by the stress. Measurements from both resistors can be used to increase sensitivity and accuracy of the strain sensor.

[0079] FIGs. 6A-6B show an example of a 3-dimensional printed part 600 that incorporates some of the features mentioned above. Particularly, the 3-dimensional printed part includes multiple resistors 610, 620 that have a curved shape and that are printed so that portions of the resistors are oriented in the z-axis direction with respect to the layers making up the printed part. The part includes a first resistor 610 embedded in the part near the inner curved surface 630 of the part. A second resistor 620 is embedded in the part near the outer curved surface 640 of the part. The first and second resistors are connected to electrical contacts 650 that are exposed at the surfaces of the part. The electrical contacts can be used to connect the resistors to a measurement circuit to measure changes in resistance of the resistor.

[0080] It is noted that, as used in this specification and the appended claims, the singular forms "a," "an," and "the" include plural referents unless the context clearly dictates otherwise.

[0081] As used herein, "liquid vehicle" or "ink vehicle" refers to a liquid fluid in which colorant is placed to form an ink. A wide variety of ink vehicles may be used with the systems and methods of the present disclosure. Such ink vehicles may include a mixture of a variety of different agents, including, surfactants, solvents, co-solvents, anti-kogation agents, buffers, biocides, sequestering agents, viscosity modifiers, surface-active agents, water, etc. Though not part of the liquid vehicle *per se*, in addition to the colorants and fusing agents, the liquid vehicle can carry solid additives such as polymers, latexes, UV curable materials, plasticizers, salts, etc.

[0082] As used herein, "colorant" can include dyes and/or pigments.

[0083] As used herein, "dye" refers to compounds or molecules that absorb electromagnetic radiation or certain wavelengths thereof. Dyes can impart a visible color to an ink if the dyes absorb wavelengths in the visible spectrum.

[0084] As used herein, "pigment" generally includes pigment colorants, magnetic particles, aluminas, silicas, and/or other ceramics, organo-metallics or other opaque particles, whether or not such particulates impart color. Thus, though the present description primarily exemplifies the use of pigment colorants, the term "pigment" can be used more generally to describe not only pigment colorants, but other pigments such as organometallics, ferrites, ceramics, etc. In one specific aspect, however, the pigment is a pigment colorant.

[0085] As used herein, "soluble," refers to a solubility percentage of more than 5 wt%.

[0086] As used herein, "ink jetting" or "jetting" refers to compositions that are ejected from jetting architecture, such as ink-jet architecture. Ink-jet architecture can include thermal or piezo architecture. Additionally, such architecture can be configured to print varying drop sizes such as less than 10 picoliters, less than 20 picoliters, less than 30 picoliters, less than 40 picoliters, less than 50 picoliters, etc.

[0087] As used herein, the term "substantial" or "substantially" when used in reference to a quantity or amount of a material, or a specific characteristic

thereof, refers to an amount that is sufficient to provide an effect that the material or characteristic was intended to provide. The exact degree of deviation allowable may in some cases depend on the specific context.

5 **[0088]** As used herein, the term “about” is used to provide flexibility to a numerical range endpoint by providing that a given value may be “a little above” or “a little below” the endpoint. The degree of flexibility of this term can be dictated by the particular variable and determined based on the associated description herein.

10 **[0089]** As used herein, a plurality of items, structural elements, compositional elements, and/or materials may be presented in a common list for convenience. However, these lists should be construed as though each member of the list is individually identified as a separate and unique member. Thus, no individual member of such list should be construed as a de facto equivalent of any other member of the same list solely based on their presentation in a
15 common group without indications to the contrary.

[0090] Concentrations, amounts, and other numerical data may be expressed or presented herein in a range format. It is to be understood that such a range format is used merely for convenience and brevity and thus should be interpreted flexibly to include not only the numerical values explicitly recited as
20 the limits of the range, but also to include individual numerical values or sub-ranges encompassed within that range as if each numerical value and sub-range is explicitly recited. As an illustration, a numerical range of “about 1 wt% to about 5 wt%” should be interpreted to include not only the explicitly recited values of about 1 wt% to about 5 wt%, but also include individual values and sub-ranges
25 within the indicated range. Thus, included in this numerical range are individual values such as 2, 3.5, and 4 and sub-ranges such as from 1-3, from 2-4, and from 3-5, etc. This same principle applies to ranges reciting only one numerical value. Furthermore, such an interpretation should apply regardless of the breadth of the range or the characteristics being described.

30

EXAMPLE

[0091] The following illustrates an example of the present disclosure.

However, it is to be understood that the following is only illustrative of the application of the principles of the present disclosure. Numerous modifications and alternative compositions, methods, and systems may be devised without departing from the spirit and scope of the present disclosure. The appended
5 claims are intended to cover such modifications and arrangements.

Example 1

[0092] A 3-dimensional printing system was used to print a strain sensor with a serpentine shaped resistor embedded in a rectangular polymer strip. A
10 conductive fusing ink, pretreat ink, and second fusing ink were printed from three separate ink jet pens. The conductive fusing ink was a silver ink (Mitsubishi NBSIJ-MU01) containing silver nanoparticles. The silver nanoparticles had an average particle size of approximately 20 nm. The pretreat ink was a solution of 3 wt% sodium chloride in water. The second fusing ink included carbon black as
15 the fusing agent and an aqueous ink vehicle.

[0093] The inks were jetted onto a bed of nylon (PA12) particles (Vestosint® x1556). The nylon particles had an average particle size of approximately 50 μm . The layer thickness was approximately 100 μm . Each layer was printed with the pretreat ink followed by the silver ink in the portions that
20 make up the resistor, and the carbon black fusing ink in the insulating portions. The inks were printed at contone levels of 255 for the silver ink, 255 for the pretreat ink, and 15 for the carbon black ink. 3 passes of the inks were performed for each layer. After each pass with the inks, a curing pass was performed. In this example, the amount of solid silver dispensed onto the powder was 141 mg/cm^3
25 of the powder layer; the amount of chloride salt dispensed was 23 mg/cm^3 of the powder layer; and the amount of carbon black dispensed was 2.3 mg/cm^3 of the powder layer.

[0094] The printer powder supply and powder bed were filled with the nylon particles. The supply temperature was set at 110 °C and the print bed
30 temperature was set at 130 °C. A heater under the print bed was set at 150 °C. The print speed was set at 10 inches per second (ips) and the cure speed was set at 7 ips. Curing was performed using two 300 W bulbs placed approximately 1 cm away from the surface of the powder bed.

[0095] Four copies of the strain sensor were printed simultaneously on a single powder bed. The four strain sensors were tested for sensitivity to changing strains. Test leads were clipped to the electrical contact pads on the sensors, and their resistances were measured with a benchtop digital multi meter. The sensors were then bent by hand 90 degrees in the direction that placed the resistors in tension, and their resistances were measured again. The sensors were then bent back to their original shape and the resistances were measured again. The measured resistances are shown in Table 7 below.

10

TABLE 7

Sensor #	R initial (ohms)	R in tension (ohms)	R final (ohms)	%delta R
1	4650	5375	4601	15.6%
2	3750	4700	3820	25.3%
3	1703	2098	1746	23.1%
4	3438	4780	3435	39%

15

[0096] Each resistor displayed a significant change in resistance when put in tension. Further, each resistor returned to nearly its original resistance when returned to its original shape. These properties make the resistors useful as strain sensors that can measure strains repeatedly with sensitivity. It should be noted that the variation in resistance between sensors 1-4 is likely caused by variations in temperature in different areas of the powder bed during printing.

CLAIMS

What is claimed is:

- 5 1. A strain sensor, comprising:
 a resistor formed of a matrix of sintered elemental transition metal particles
interlocked with a matrix of fused thermoplastic polymer particles;
 a first electrical contact at a first end of the resistor; and
 a second electrical contact at a second end of the resistor.
- 10 2. The strain sensor of claim 1, wherein the elemental transition metal
particles comprise silver particles, copper particles, gold particles, or
combinations thereof.
- 15 3. The strain sensor of claim 1, wherein the matrix of fused thermoplastic
polymer particles comprises a fusing agent selected from carbon black, a near-
infrared absorbing dye, a near-infrared absorbing pigment, a tungsten bronze, a
molybdenum bronze, metal nanoparticles, a conjugated polymer, or combinations
thereof.
- 20 4. The strain sensor of claim 1, wherein the resistor further comprises a
halogen salt in the matrix of sintered elemental transition metal particles, the
matrix of fused thermoplastic polymer particles, or both.
- 25 5. The strain sensor of claim 1, wherein the resistor has a resistance from
1 ohm to 1 Mega ohm.
6. A 3-dimensional printed part having an integrated strain sensor,
comprising:
- 30 a part body formed of fused thermoplastic polymer particles; and
 a resistor formed of a matrix of sintered elemental transition metal particles
interlocked with a matrix of fused thermoplastic polymer particles, wherein the

matrix of fused thermoplastic polymer particles is continuously fused to the fused thermoplastic polymer particles of the part body.

7. The 3-dimensional printed part of claim 6, wherein the elemental
5 transition metal particles comprise silver particles, copper particles, gold particles, or combinations thereof.

8. The 3-dimensional printed part of claim 6, wherein the fused
10 thermoplastic polymer particles comprise a fusing agent selected from carbon black, a near-infrared absorbing dye, a near-infrared absorbing pigment, a tungsten bronze, a molybdenum bronze, metal nanoparticles, a conjugated polymer, or combinations thereof.

9. The 3-dimensional printed part of claim 6, wherein the resistor further
15 comprises a halogen salt in the matrix of sintered elemental transition metal particles, the matrix of fused thermoplastic polymer particles, or both.

10. The 3-dimensional printed part of claim 6, wherein the resistor has a
20 resistance from 1 ohm to 1 Mega ohm.

11. The 3-dimensional printed part of claim 6, wherein the resistor is
embedded in the part body.

12. The 3-dimensional printed part of claim 6, wherein the part is formed of
25 multiple layers of fused thermoplastic polymer particles stacked in a z-axis direction, and wherein the resistor is oriented at least partially in the z-axis direction.

13. A method of making a 3-dimensional printed part having an integrated
30 strain sensor, the method comprising:

dispensing a conductive fusing ink onto a first area of a layer of thermoplastic polymer particles, wherein the conductive fusing ink comprises a transition metal;

dispensing a second fusing ink onto a second area of the layer of thermoplastic polymer particles, wherein the second fusing ink comprises a fusing agent capable of absorbing electromagnetic radiation to produce heat; and

5 fusing the first and second areas with electromagnetic radiation to form a resistor in the first area and a part body in the second area, wherein the resistor comprises a matrix of sintered transition metal particles interlocked with a matrix of fused thermoplastic polymer particles, and the part body comprises fused thermoplastic polymer particles.

10 14. The method of claim 13, wherein the resistor is formed at least partially oriented in a z-axis direction such that the resistor extends across multiple layers of the 3-dimensional printed part.

15 15. The method of claim 13, wherein the transition metal is in the form of elemental transition metal particles.

1/4

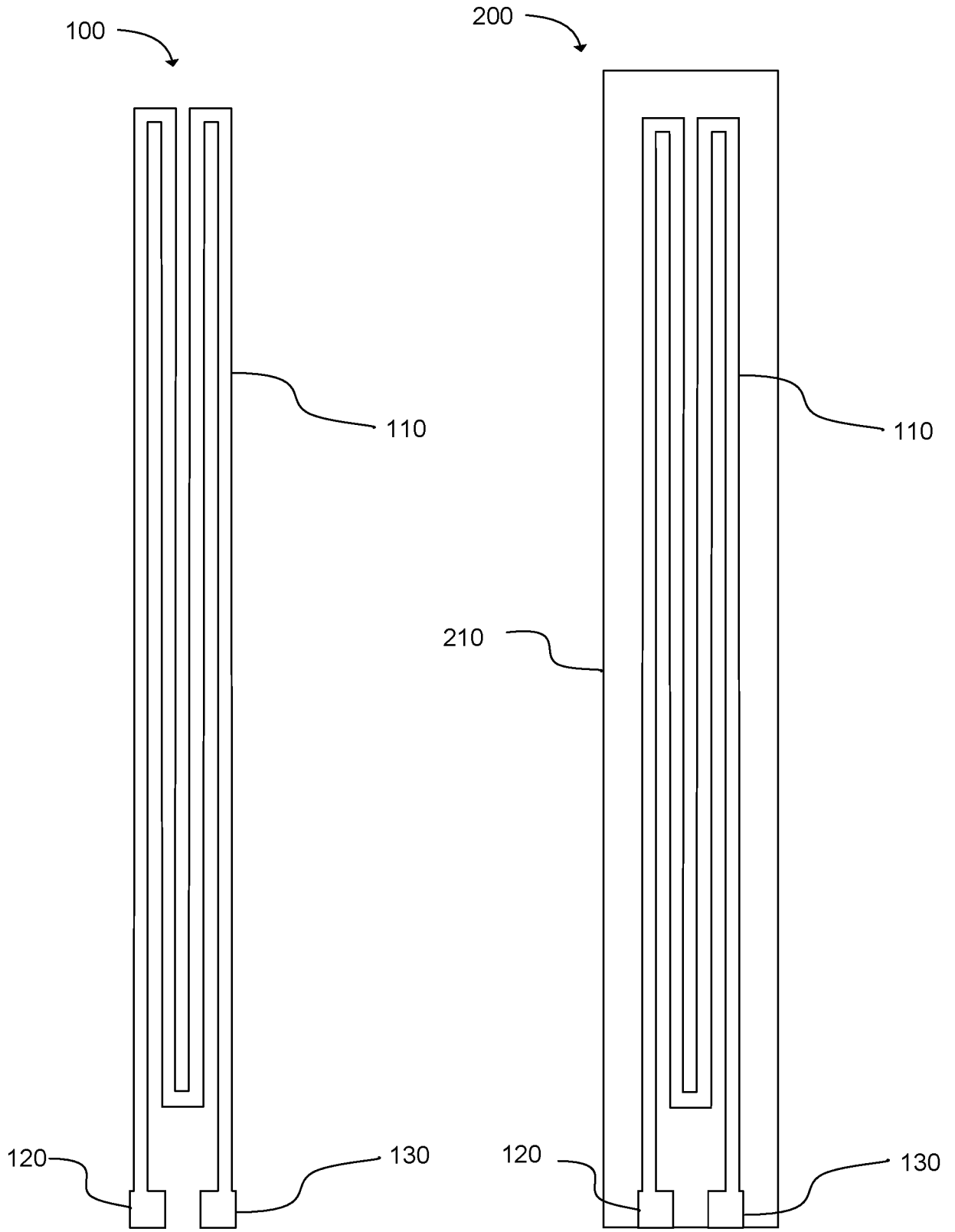
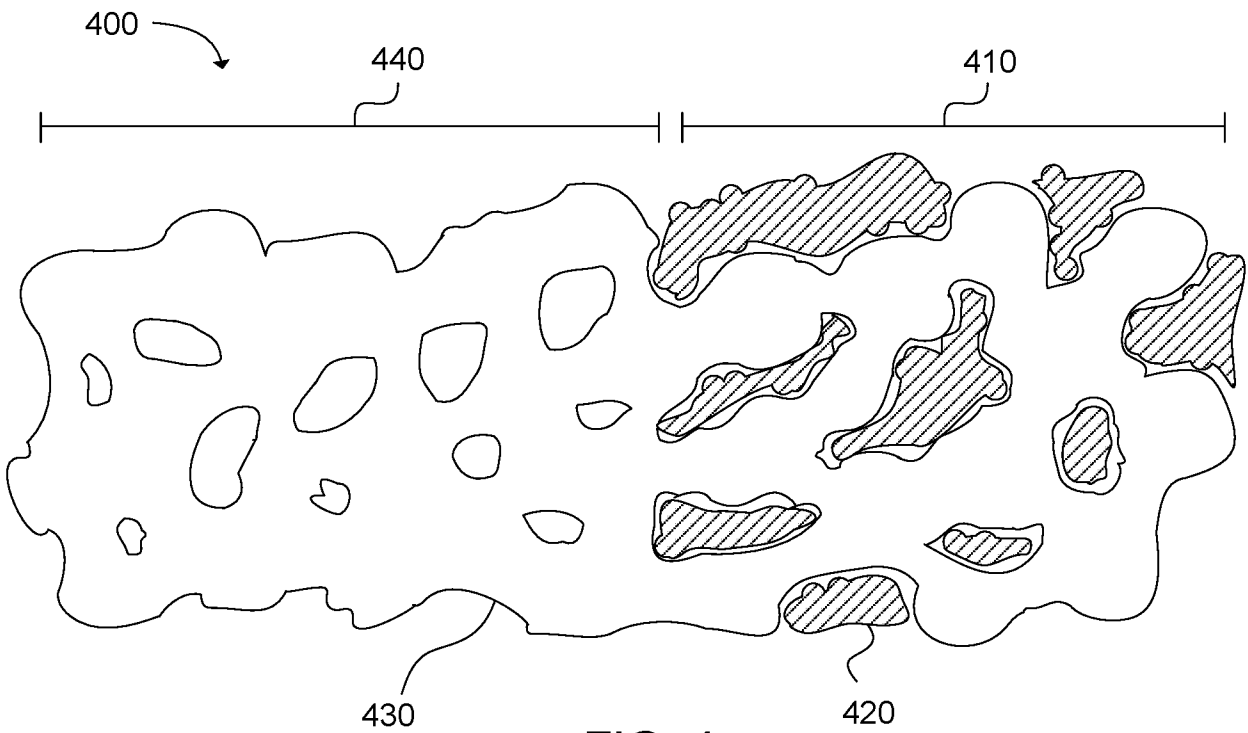
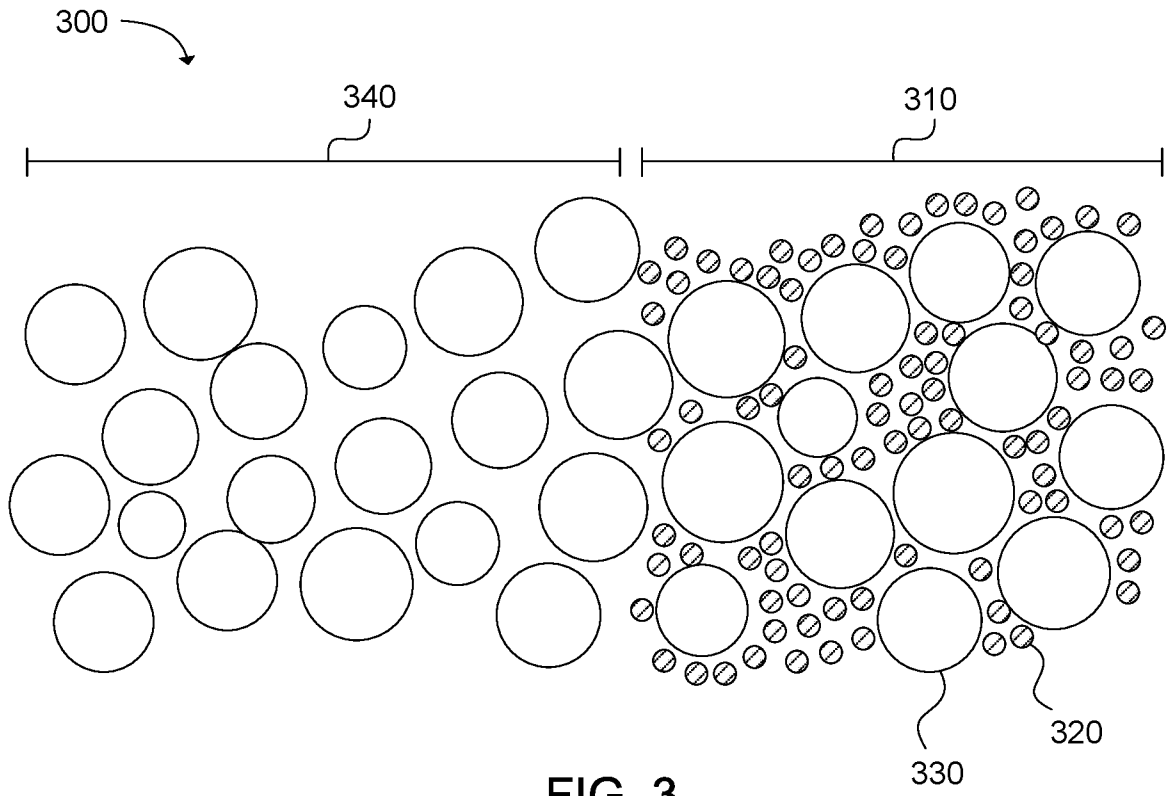

FIG. 1

FIG. 2



3/4

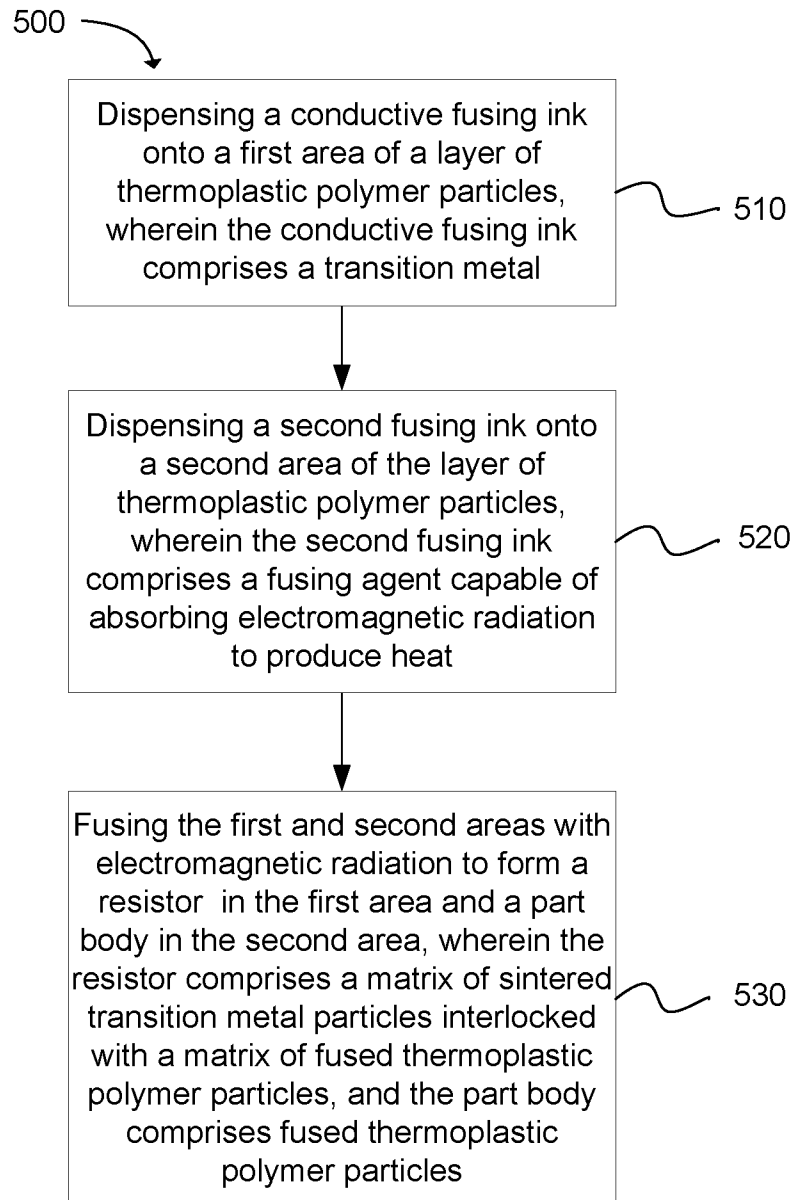

FIG. 5

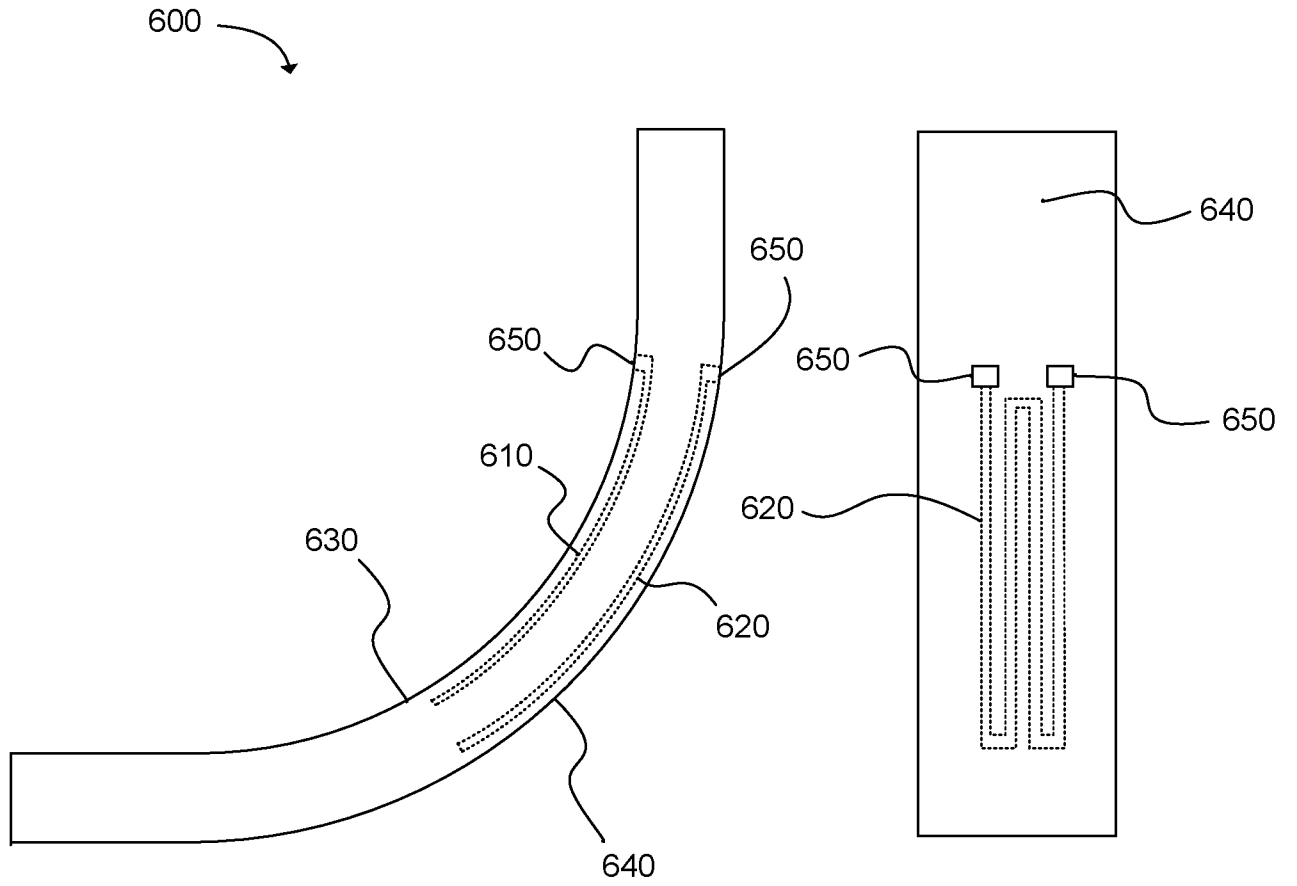

FIG. 6A

FIG. 6B

A. CLASSIFICATION OF SUBJECT MATTER**G01B 7/16(2006.01)i**

According to International Patent Classification (IPC) or to both national classification and IPC

B. FIELDS SEARCHED

Minimum documentation searched (classification system followed by classification symbols)

G01B 7/16; G01L 1/22; G01L 5/10; H01B 1/22; B29C 71/04; H01L 41/29; A61B 5/022; G01D 11/00; A61F 2/10; B29C 35/08

Documentation searched other than minimum documentation to the extent that such documents are included in the fields searched

Korean utility models and applications for utility models

Japanese utility models and applications for utility models

Electronic data base consulted during the international search (name of data base and, where practicable, search terms used)

eKOMPASS(KIPO internal) & keywords: strain gauge, 3D print, metal, sintered and ink

C. DOCUMENTS CONSIDERED TO BE RELEVANT

Category*	Citation of document, with indication, where appropriate, of the relevant passages	Relevant to claim No.
Y	WO 2015-193045 A1 (STBL MEDICAL RESEARCH AG et al.) 23 December 2015 See page 5, lines 3-11, page 17, line 10-page 25, line 24 and figures 1-4.	1-12
A		13-15
Y	JP 2005-353337 A (MATSUSHITA ELECTRIC IND. CO., LTD.) 22 December 2005 See paragraphs [0016]-[032] and figures 1(a), 1(b).	1-12
A		13-15
A	US 2007-0241482 A1 (GILLER et al.) 18 October 2007 See paragraphs [0056]-[0155] and figures 1a, 1b.	1-15
A	US 2013-0079693 A1 (NORTHEASTERN UNIVERSITY) 28 March 2013 See abstract and figure 2.	1-15
A	US 2014-0238153 A1 (WOOD et al.) 28 August 2014 See abstract and figure 5.	1-15

 Further documents are listed in the continuation of Box C. See patent family annex.

* Special categories of cited documents:

"A" document defining the general state of the art which is not considered to be of particular relevance

"E" earlier application or patent but published on or after the international filing date

"L" document which may throw doubts on priority claim(s) or which is cited to establish the publication date of another citation or other special reason (as specified)

"O" document referring to an oral disclosure, use, exhibition or other means

"P" document published prior to the international filing date but later than the priority date claimed

"T" later document published after the international filing date or priority date and not in conflict with the application but cited to understand the principle or theory underlying the invention

"X" document of particular relevance; the claimed invention cannot be considered novel or cannot be considered to involve an inventive step when the document is taken alone

"Y" document of particular relevance; the claimed invention cannot be considered to involve an inventive step when the document is combined with one or more other such documents, such combination being obvious to a person skilled in the art

"&" document member of the same patent family

Date of the actual completion of the international search

09 December 2016 (09.12.2016)

Date of mailing of the international search report

14 December 2016 (14.12.2016)

Name and mailing address of the ISA/KR

International Application Division

Korean Intellectual Property Office

189 Cheongsa-ro, Seo-gu, Daejeon, 35208, Republic of Korea

Facsimile No. +82-42-481-8578

Authorized officer

HAN, JOONG SUB

Telephone No. +82-42-481-3578



INTERNATIONAL SEARCH REPORT

Information on patent family members

International application No.

PCT/US2016/027968

Patent document cited in search report	Publication date	Patent family member(s)	Publication date
WO 2015-193045 A1	23/12/2015	EP 2957225 A1	23/12/2015
JP 2005-353337 A	22/12/2005	JP 4475022 B2	09/06/2010
US 2007-0241482 A1	18/10/2007	EP 2001656 A2	17/12/2008
		EP 2001656 B1	15/10/2014
		WO 2007-114895 A2	11/10/2007
		WO 2007-114895 A3	21/02/2008
US 2013-0079693 A1	28/03/2013	EP 2764557 A1	13/08/2014
		EP 2764557 A4	27/04/2016
		JP 2014-533975 A	18/12/2014
		US 9228859 B2	05/01/2016
		WO 2013-049188 A1	04/04/2013
US 2014-0238153 A1	28/08/2014	CN 103959029 A	30/07/2014
		EP 2758760 A2	30/07/2014
		JP 2014-528079 A	23/10/2014
		KR 10-2014-0078704 A	25/06/2014
		WO 2013-044226 A2	28/03/2013
		WO 2013-044226 A3	11/07/2013