

Jan. 15, 1963

G. F. A. DAUMY

3,073,565

GATE-VALVE

Filed Nov. 1, 1961

2 Sheets-Sheet 1

FIG. 1

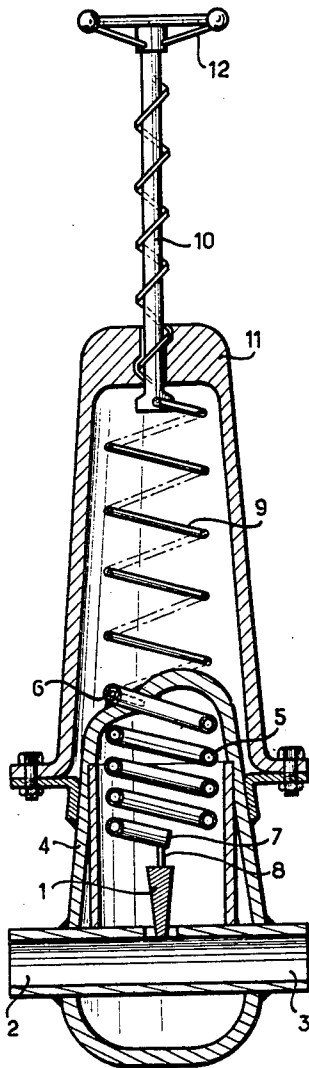
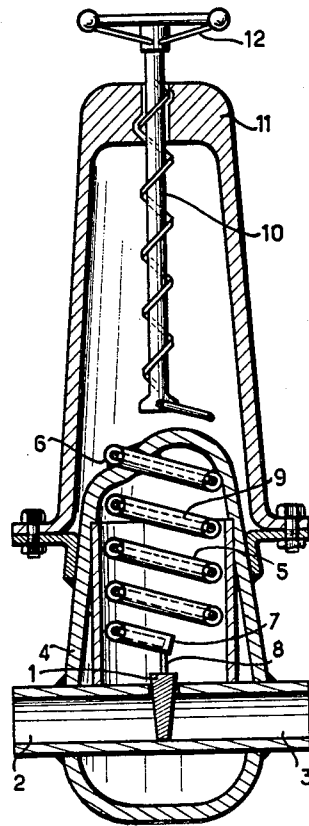

FIG. 2



INVENTOR

GEORGES FRANCIS ALEXIS DAUMY

By *Irwin d. Thompson*

ATTY.

Jan. 15, 1963

G. F. A. DAUMY

3,073,565

GATE-VALVE

Filed Nov. 1, 1961

2 Sheets-Sheet 2

FIG. 3

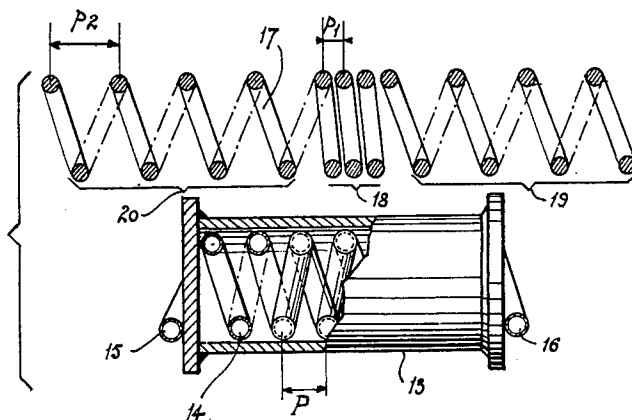

FIG. 4

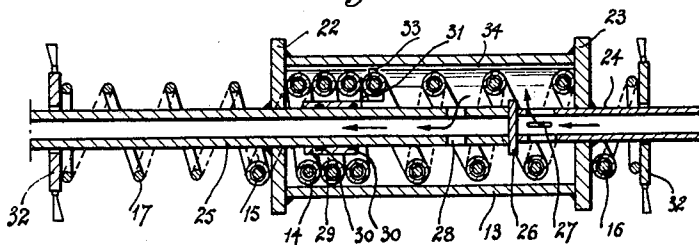
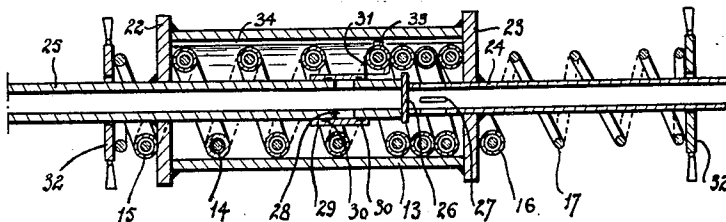

FIG. 5



INVENTOR

GEORGES FRANCIS ALEXIS DAUMY

BY *Irwin D. Thompson*

ATTY.

1

3,073,565
GATE-VALVE

Georges F. A. Daumy, Seyssins (Isere), France
Filed Nov. 1, 1961, Ser. No. 149,274
Claims priority, application France Dec. 23, 1960
4 Claims. (Cl. 251-229)

The present invention has for its object a control device for a gate-valve which is absolutely fluid-tight with respect to the exterior.

In the gate-valves currently in use, it is not possible to obtain perfect fluid-tightness by reason of the possibilities of leakage through the joints, packing-glands and screwed or bolted assemblies, which form part of the constitution of these gate-valves. Now, a perfect fluid-tightness may be advantageous and sometimes even necessary in the case of fluids of high purity, or of toxic or dangerous fluids, such as those which may be employed in certain chemical industries or in nuclear installations.

In order to obtain this fluid-tightness, it has already been proposed, by arranging the closure member of the valve in a fluid-tight body, to operate the said closure member by the torsion of a spring inserted into a tubular coil closed at the extremity which is coupled to the closure member extending into the fluid-tight body and passing out from the exterior of the latter at its other extremity.

In this arrangement, the spiral spring and the tubular coil are essentially and permanently coupled together: they have the same winding pitch. It is the torsion of the spring, sheathed in a fluid-tight manner by the coil, which ensures the movement of the closure member.

The present invention has for its object a device of the kind referred to above, having a spring associated with a coil, but offering many advantages as compared with the prior arrangements.

This device is characterized in that the spiral spring is mounted freely movable inside the coil and is provided wholly or partly with one or more winding pitches different from the pitch of the coil.

As distinct from the prior solution, the spring is not connected at any point of its length with the tubular coil. It moves freely, sliding helicoidally inside the coil into which it penetrates and from which it passes out. It is because of the difference in the winding pitches that there is produced a deformation of the coil which actuates the closure device of the gate-valve. The torsion of the spring results, not in a rotation, but in a lateral movement parallel to the common winding axis of the coil and the spring, of a portion of the coil which is coupled to the closure member.

With the device according to the invention, a straight-line motion is obtained which permits the actuation of a sliding shutter, this method of operation not being possible of achievement with the prior solution, except by the use of substantial mechanical complications. Movements of large amplitude are obtained. In addition, the stresses due to the spring result in a simple torsion of the tube forming the coil, with lower stresses produced in the metal.

The accompanying drawings show by way of example two forms of embodiment of the valve-operating device in accordance with the invention.

FIGS. 1 and 2 show a longitudinal cross-section of a first form of embodiment, FIG. 1 showing the gate-valve in the open position, while FIG. 2 shows the closed position.

FIGS. 3 to 5 show a further form of embodiment.

FIG. 3 shows a diagrammatic view of the spring and the coil which constitute the operating member of the valve;

2

FIG. 4 is a longitudinal cross-section of the gate-valve in the open position;

FIG. 5 shows the gate-valve in the closed position.

In the gate-valve shown in FIGS. 1 and 2, the closure member is constituted by a sliding shutter 1, arranged between the incoming conduit 2 and the outgoing conduit 3. The sliding shutter 1 is enclosed in a fluid-tight metal bell 4, welded on the conduits 2 and 3. A metal coil 5, the interior of which is in communication with the exterior of the bell 4 passes into the said bell in the vicinity of its upper extremity 6, which is welded to the bell. The lower extremity 7 of the coil 5 is closed by welding. It is fixed on the operating rod 8 of the sliding shutter 1. A spiral metal spring 9 is inserted in the coil 5. This spring is adapted to rotate with a corkscrew movement inside the coil 5, under the action of a threaded rod 10 guided by a frame 11 and operated by a hand-wheel 12. The winding diameter of the spiral spring 9 is the same as that of the coil 5, but its winding pitch is greater than that of the coil.

As shown in FIG. 1, when the threaded rod 10 causes the spiral spring 9 to free itself from the coil 5, the latter is not acted upon in any way by the spiral spring 9. The coil 5 then has its normal form and its normal length, so that its lower extremity 7 holds the sliding shutter 1 in the open position by means of the operating rod 8.

As shown in FIG. 2, when the threaded rod 10 causes the spiral spring 9 to be fully introduced into the coil 5, the latter is deformed by the spiral spring 9 into a position of maximum elongation. The lower extremity 7 of the coil then holds the sliding shutter 1 in the closure position by means of the operating rod 8.

When the threaded rod 10 causes the spiral spring 9 to be partly introduced into the coil 5, the latter is deformed by the spiral spring 9 into an intermediate position of elongation. The lower extremity 7 of the coil then holds the sliding shutter 1 in a position of partial opening, through the intermediary of the operating rod 8.

The flow of fluid which it is desired to interrupt or regulate cannot under any circumstances pass to the exterior of the fluid-tight bell 4 which is welded on the incoming and outgoing conduits. The fluid is in fact permanently retained inside metallic chambers which are welded to each other in a fluid-tight manner. The operation of the closure shutter 1 is effected from outside the bell through the deformable fluid-tight wall constituted by the coil.

In the form of embodiment shown in FIGS. 3 to 5, the operating member with a coil and spring is arranged so as to actuate a valve closure member arranged inside an absolutely fluid-tight chamber 13, the actuating member not being directly accessible. The tubular coil 14 is arranged inside the chamber 13 and passes right through the said chamber. The extremities 15 and 16 are rigidly fixed to the chamber 13. They are open and lead to the exterior of the chamber 13. The spirals of the coil 14 are wound with a constant pitch P . The coil is however deformable, and the pitch can be modified by an appropriate action.

This action is ensured by the insertion into the tubular coil 14 of a coil of a spiral spring 17, which is provided along its length with zones having different pitches: for example, a central zone 18 having a small pitch P_1 and lateral zones 19 and 20 having a larger pitch P_2 . The relative values of the pitches are such that P is intermediate between P_1 and P_2 ($P_1 < P < P_2$). The spring 17 is introduced into the coil 14 by rotation in the manner of a corkscrew, so that the portion 18 of the spring having a smaller pitch is located in the coil, moving between the extremities 15 and 16 of the coil, going from one to the other and vice versa.

In the application to a gate-valve having a sleeve closure device as shown in FIGS. 4 and 5, the fluid-tight chamber 13 of cylindrical shape with ends 22 and 23, is mounted by these end-plates concentrically on the fluid conduit, constituted by two sections of piping 24 and 25 in alignment and having an intermediate collar 26. The section 24 is provided at 27 with orifices opening into the chamber 13. On the section 25, the communication with the chamber 13 is effected by the orifices 28. In front of these orifices slides a sleeve 29 with sealing rings 30 attached at 31 to the coil 14. It is this sleeve 29 which, by closing the orifices 28, ensures the opening or the closure of the passage of fluid from 27 to 25 by flowing through the chamber 13. This sleeve 29 is actuated by the movement of the coil 14 due to the introduction of the spring 17.

The spring 17 is coupled at its two extremities to hand-wheels 32 or equivalent devices rotating freely on the conduits 24 and 25.

It will be understood that by rotating the hand-wheels 32 in the manner of the corkscrew, the spring 17 moves inside the coil 14, the portion 18 with close turns coming to the left of FIG. 4, which deforms the coil 14 and causes a sliding movement of the sleeve 29 resulting in the opening of the orifices 28. As a communication is established from 24 to 25 through the orifices 27, the chamber 13 and the orifices 28 as indicated by the arrows, the fluid is allowed to pass.

By rotating the hand-wheels 32 in the opposite direction, the portion 18 of the spring with close turns is caused to move in the opposite direction, namely towards the right hand side, as shown in FIG. 3. The coil is deformed and carries the sleeve 29 towards the right. The sleeve then closes the orifices 28, cutting off the passage of the fluid.

At any point of the coil 14 is fixed a tenon 33 which engages in a groove 34 in the chamber 13 so as to prevent any rotation of the coil.

It will be observed that this embodiment provides a compact and rigid construction of the gate-valve with its operating gear. In addition, it permits of the utilization, not only of the expansion but also the compression of the spirals of the coil, which increases the useful travel of the operating device of the closure member.

The device according to the invention is of course not limited to the forms of embodiment described and shown. It may include any alternative forms. In particular, the closure member may be of any form or shape, actuated by sliding or by rotation. The coupling with the deformable portion of the coil may be effected by any appropriate mechanical means. In the same way, the actua-

tion device for the spiral spring may be of any desired form.

What I claim is:

1. A gate-valve with a fluid-tight control for a fluid conduit, comprising a closure member on the fluid conduit, a fluid-tight chamber around said closure member, a tubular coil coupled to said closure member and fixed at at least one of its extremities in a fluid-tight manner to said fluid-tight chamber and opening to the exterior of said chamber, a spiral spring having over at least a portion of its length winding pitch different from that of said tubular coil, means for controllably advancing said spring in said coil.

2. A gate-valve with a fluid-tight control for a fluid conduit, comprising a closure member on said fluid conduit, a fluid-tight chamber around said closure member, a tubular coil coupled to said member by one of its extremities which is closed, and fixed at the other extremity in a fluid-tight manner to said fluid-tight chamber and opening into the exterior of said chamber, a spiral spring having a winding pitch different from that of said tubular coil, inserted in said coil, and a member controlling the extent of insertion of said spring into said coil.

3. A gate-valve with a fluid-tight control for a fluid conduit, comprising a closure member on said fluid conduit, a fluid-tight chamber around said closure member, a tubular coil coupled to said closure member and fixed at its two extremities in a fluid-tight manner to said chamber and opening to the exterior at its two extremities, a spiral spring having over a portion of its length a winding pitch smaller than the pitch of said coil, said spring being inserted into said coil, said portion arranged to coact with said coil, and means for applying torsion to said spring to ensure the insertion and the displacement of said spring in said coil.

4. A gate-valve with a fluid-tight control for a fluid conduit comprising a fluid conduit with internal closure and passage orifices on each side of said closure, a sleeve sliding over one of said passage orifices, a fluid-tight chamber around said conduit enclosing the sliding zone of said sleeve, a tubular coil coaxial with said conduit and fixed at its two extremities to said fluid-tight chamber and opening to the exterior, a spiral spring inserted in said coil and having a portion with a winding pitch less than the winding pitch of said coil, said portion arranged to coact with the coil, and torsion means fixed at the two extremities of said spring to ensure the displacement of said spring in said coil.

No references cited.