

No. 725,465.

PATENTED APR. 14, 1903.

C. H. MASON.
GRAIN DRILL.

APPLICATION FILED JAN. 6, 1903.

NO MODEL.

2 SHEETS—SHEET 1.

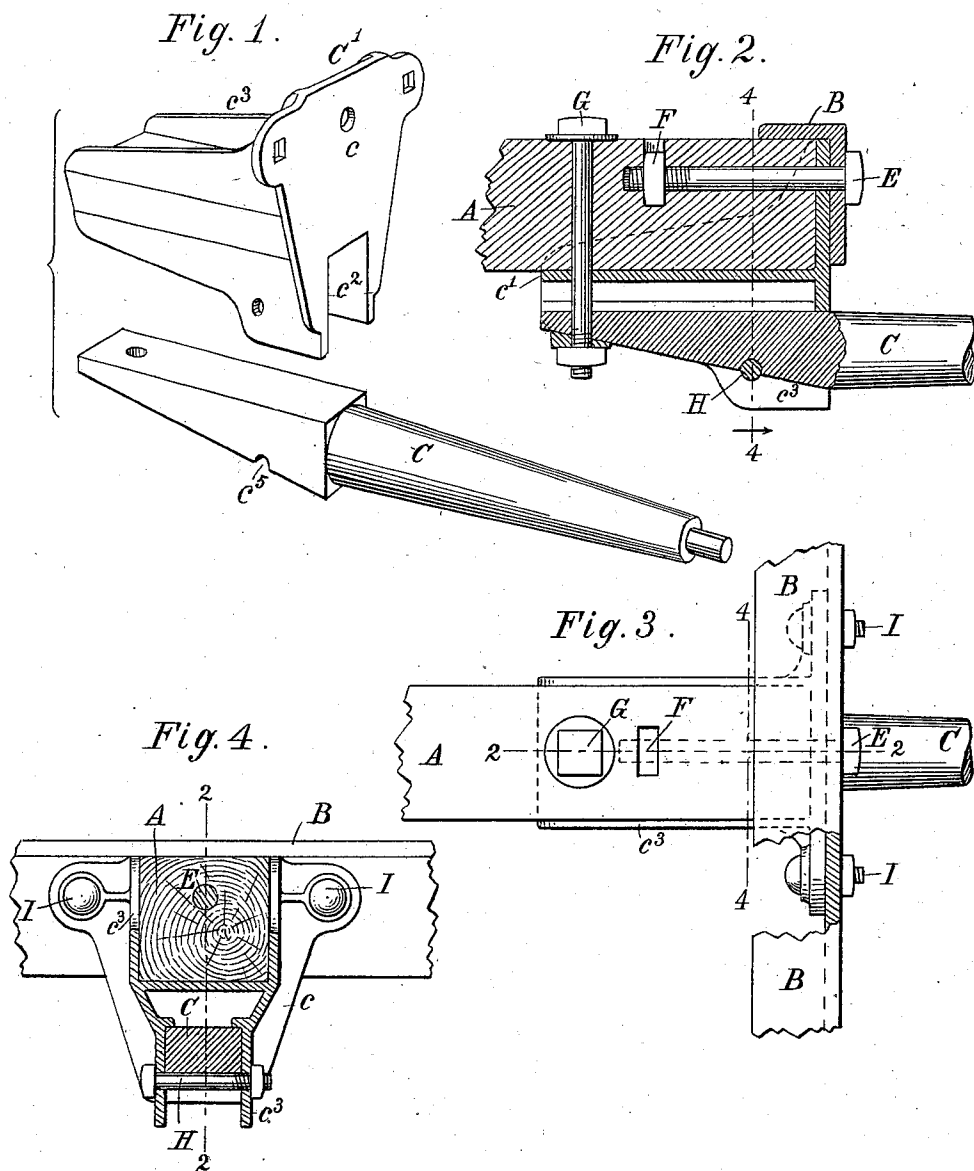

WITNESSES:

M. R. Kennedy
F. J. Elmore

INVENTOR

C. H. Mason

BY

Phil. T. Dodge
ATTORNEY

No. 725,465.

PATENTED APR. 14, 1903.

C. H. MASON.
GRAIN DRILL.

APPLICATION FILED JAN. 6, 1903.

NO MODEL.

2 SHEETS—SHEET 2.

Fig. 5.

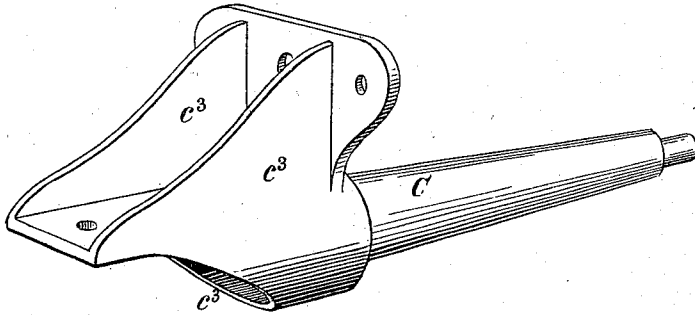
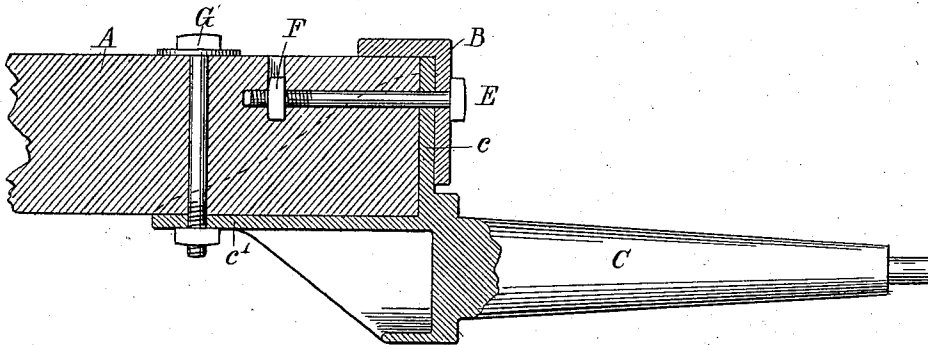

Fig. 6.



WITNESSES:

N. R. Kenney
F. J. Elmore

INVENTOR

C. H. Mason

BY

Phil T. Sodge
ATTORNEY

UNITED STATES PATENT OFFICE.

CHARLES H. MASON, OF SHORTSVILLE, NEW YORK.

GRAIN-DRILL.

SPECIFICATION forming part of Letters Patent No. 725,465, dated April 14, 1903.

Application filed January 6, 1903. Serial No. 138,058. (No model.)

To all whom it may concern:

Be it known that I, CHARLES H. MASON, of Shortsville, county of Ontario, and State of New York, have invented a new and useful Improvement in Grain-Drills, of which the following is a specification.

This invention has reference particularly to agricultural and analogous machines wherein the horizontal main frame is carried by a transverse wooden axle having attached to its ends the spindles or short axles to receive the supporting and driving wheels. In this class of machines as heretofore constructed the spindles were commonly made of cast-iron, with flanges adapted to be bolted to the outside of the longitudinal frame-timbers. The construction and mode of attachment were such as to prevent a proper strengthening and bracing of the spindles, the results of which were an insecure connection to the frame and the frequent breakage of the spindle at or near the frame.

My improved spindle, designed to avoid the difficulties named, may be made in one or two parts and is provided with a transverse flange adapted to be bolted to the inside, as distinguished from the outside, of the longitudinal frame members and also provided with one or more longitudinal flanges, whereby the other parts are strengthened and tied together, so that breakage is impossible.

My invention consists, further, in a peculiar construction of the spindle in two parts—one a flanged cast-iron member having the characteristics above named and the other the spindle proper, of forged steel or equivalent metal, adapted to be seated in the first member, as hereinafter described in detail.

Referring to the drawings, Figure 1 represents my improved two-part spindle, the parts being separated. Fig. 2 is a longitudinal vertical section through the same applied to the frame of a machine, the view being taken on the lines 2 2 of Figs. 3 and 4. Fig. 3 is a top plan view of the same. Fig. 4 is a vertical cross-section on the line 4 4 of Figs. 2 and 3. Fig. 5 is a perspective view of the spindle constructed in one piece. Fig. 6 is a longitudinal vertical section of the same in position for use.

Referring to Figs. 2, 3, and 4, A represents a square wooden axle, to the ends of which

is attached the wheel-carrying spindle. B represents one of the longitudinal side bars of the frame, usually a steel angle-bar of 7 55 form, as shown. C represents the spindle proper to receive the main wheel, its outer end being tapered, as usual, and its inner end made of angular cross-section. C' represents a cast-metal socket or bearing plate constituting the second part of the spindle. It is constructed, as shown, with a vertical transverse flange *c*, adapted to be seated against the inner face of the frame-bar B and against the end of the axle A, also with a longitudinal flange *c'* to underlie the axle, also with a longitudinal cavity or recess *c²* in the under side to receive the inner end of the spindle C, and with a longitudinal vertical flange *c³* on one or both sides. These side flanges *c³* 60 serve to stiffen and strengthen the outer flange *c*, to tie it firmly to the flange *c'*, and also serve as side plates or bearings for the axle A on the inner end of the spindle C.

When the parts are assembled, a bolt E is 75 passed horizontally through the vertical flange of the frame-bar B and also through the flange *c* endwise into the axle and through a nut F, seated therein, the nut being inserted from one side. A vertical bolt G is also passed 80 down through the axle and through the inner end of the spindle C. A third bolt H is passed horizontally through the groove *c⁵* in the inner end of the spindle C and through the cheek plates or flanges *c³*. 85

When the parts are combined as above described, it will be observed that the spindle C is extended inward beneath the axle A and tied firmly thereto by the bolt G, the intermediate casting, and the bolt E. The bolt H 90 serves not only to keep the spindle in place in the casting, but to strengthen the latter by tying its flanges together in a fore-and-aft direction, so that there will be no danger of its being fractured by the transverse strains 95 received from the spindle.

The bolt E serves the twofold purpose of holding the axle both longitudinally and vertically to a firm seat in the casting and of tying the flange of the casting and the frame 100 firmly to each other and to the axle.

It is to be particularly noted that the location of the flange *c* on the inside of the frame-bar B renders possible the use of the longi-

tudinal stiffening-flanges c^3 . As these flanges extend from the flange c downward along the sides of the axle and the underlying plate c' , the parts are adapted to withstand the most severe strain encountered in practice, and the fractures which commonly occur near the outer end of the axle under the ordinary construction of the parts are rendered impossible.

10 The flange c is preferably extended forward and backward beyond the flanges c^3 and perforated to receive transverse bolts I, passed through the frame member B for the purpose of binding the parts more securely together.

15 It is manifest that the form and extent of the flange c may be modified at will, provided only it is adapted to be seated on the inside of the frame and is strengthened or braced on the inner side.

20 The essence of the invention as regards the foregoing construction lies, first, in the adaptation of the spindle-carrying flange c to bear against the inside of the frame member B and the combination therewith of one or more

25 strengthening-flanges c^3 , and, secondly, in the construction of the spindle proper and its supporting member in separate cooperating parts, substantially as shown.

30 Figs. 5 and 6 illustrate another form of spindle containing the first feature of my invention. This spindle is cast complete in one piece, the spindle proper, C, having integral therewith the flanges c , c' , and c^3 , of essentially the same form and arrangement as those represented in the first-described construction.

35 In using this form of the device the wooden axle A is inserted between the flanges c^3 and against the flange c on top of the flange c' . The horizontal and vertical bolts E and G are applied, as in the first instance, to bind the parts together. It will be observed that in this construction, as in the first, the flange c is adapted to lie against the inner face of the frame member B between it

45 and the axle and that this flange receives, as in the first place, strong support from the longitudinal flanges c^3 , so that the spindle and the axle are held firmly in their required relations and fracture of the flange c' prevented.

50 It will be observed in each form of the device herein shown that the horizontal flange c' and the side flanges c^3 constitute jointly a seat or socket to receive the end of the wooden axle and that in the two-part device the side flanges and the ribs or flanges on their inner faces form a seat or bearing for the inner end of the spindle C.

60 It is manifest that the inner end of the spindle C may be modified in form at will and the bearing-surfaces in the casting made of corresponding form, provided the parts retain the functions and mode of action herein shown.

It is manifest that either of the flanges c^3 may be omitted without departing from the scope of my invention; but the use of both flanges is preferred because of the increased strength. It is also manifest that the number of vertical connecting-bolts may be modified at the will of the constructor, the number of bolts employed not being of the essence of my invention.

Having described my invention, what I claim is—

1. A spindle, having at the inner end a transverse flange strengthened on the inner side, and having its outer side adapted for application to the inside of a longitudinal frame member, substantially as described.

2. A spindle C, having a transverse vertical flange c , having its ends projected horizontally beyond the spindle proper, a flange c' to underlie the axle, and strengthening-flanges c^3 .

3. In a spindle, the spindle proper, having at its inner end a transverse flange, adapted to be seated between the frame member and the end of the axle, and flanges c^3 extending from the first-named flange lengthwise of the axle.

4. The combination of an axle A, a longitudinal frame member B, and a spindle C having a flange c inserted between the frame member and the axle, a horizontal flange c' extending lengthwise of the axle, and vertical flanges, the several parts being united by bolts, substantially as described.

5. A spindle, consisting of a spindle proper, an inwardly-extending flange for application to the axle, and a transverse flange braced on the inner side, substantially as shown.

6. A spindle, comprising the spindle proper C with an angular inner end, and a casting c' recessed to receive the spindle and provided with flanges, substantially as shown.

7. In a spindle, the spindle C having an angular inner end, and a casting c' having in its upper side a seat to receive a wooden axle and in its under side a seat to receive the end of the spindle, said casting provided with transverse and longitudinal flanges and with openings to receive vertical and horizontal bolts.

8. The combination of the axle A, the frame member B, the spindle C, the intermediate casting having flanges c , c' and c^3 , the vertical bolt G, the transverse bolt H, and a bolt connecting the casting with the frame member.

In testimony whereof I hereunto set my hand, this 30th day of December, 1902, in the presence of two attesting witnesses.

CHARLES H. MASON.

Witnesses:

JOHN F. GEORGE,

P. T. DODGE.