



US00D505400S

(12) **United States Design Patent**
Kawafuji et al.

(10) **Patent No.:** **US D505,400 S**

(45) **Date of Patent:** **** May 24, 2005**

(54) **SEMICONDUCTOR DEVICE**

D448,740 S * 10/2001 Iwasaki et al. D13/182
D472,530 S * 4/2003 Iwasaki et al. D13/182

(75) Inventors: **Hisashi Kawafuji**, Fukuoka (JP);
Tatsuyuki Takeshita, Fukuoka (JP)

FOREIGN PATENT DOCUMENTS

(73) Assignee: **Mitsubishi Denki Kabushiki Kaisha**,
Tokyo (JP)

JP 098 288 601 6/1997
JP 106 57 0100 4/2000

(**) Term: **14 Years**

* cited by examiner

(21) Appl. No.: **29/213,816**

Primary Examiner—Stella Reid
Assistant Examiner—Selina Sikder
(74) *Attorney, Agent, or Firm*—Sughrue Mion, PLLC

(22) Filed: **Sep. 24, 2004**

(57) **CLAIM**

(30) **Foreign Application Priority Data**

The ornamental design for a semiconductor device, as shown and described.

Mar. 26, 2004 (JP) 2004-009136

(51) **LOC (7) Cl.** **13-03**

DESCRIPTION

(52) **U.S. Cl.** **D13/182**

(58) **Field of Search** D13/182; 174/52.1,
174/52.2, 52.4; 257/666, 669, 675, 676,
678, 690, 692, 696, 697, 730, 787; 361/773,
820; 438/64, 65

FIG. 1 is a front, top and right side perspective view of a semiconductor device, showing our new design; FIG. 2 is a front elevational view thereof; FIG. 3 is a rear elevational view thereof; FIG. 4 is a top plan view thereof; FIG. 5 is a bottom plan view thereof; FIG. 6 is a left side elevational view thereof; FIG. 7 is a right side elevational view thereof; and, FIG. 8 is an enlarged cross-sectional view thereof and, taken along line 8—8 of FIG. 2, with the internal system omitted.

(56) **References Cited**

U.S. PATENT DOCUMENTS

D394,244 S * 5/1998 Majumdar et al. D13/182
D401,912 S 12/1998 Majumdar et al.
D418,185 S 12/1999 McCormick et al.
D448,739 S * 10/2001 Iwasaki et al. D13/182

1 Claim, 4 Drawing Sheets

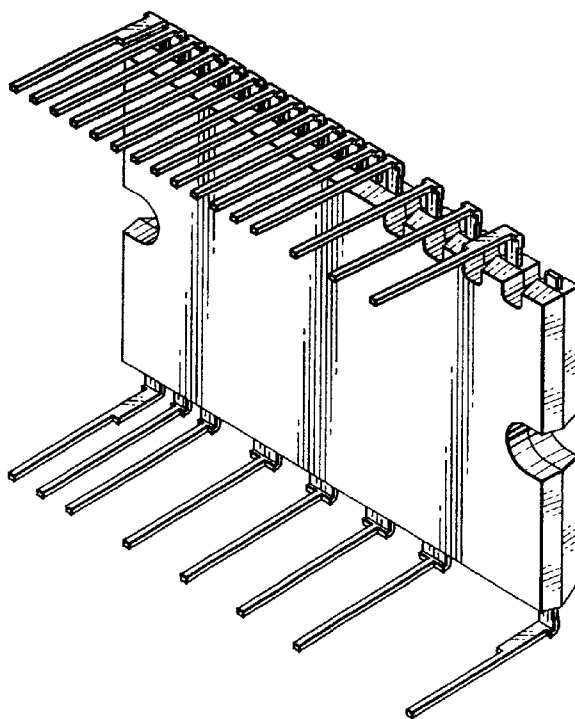

FIG. 1

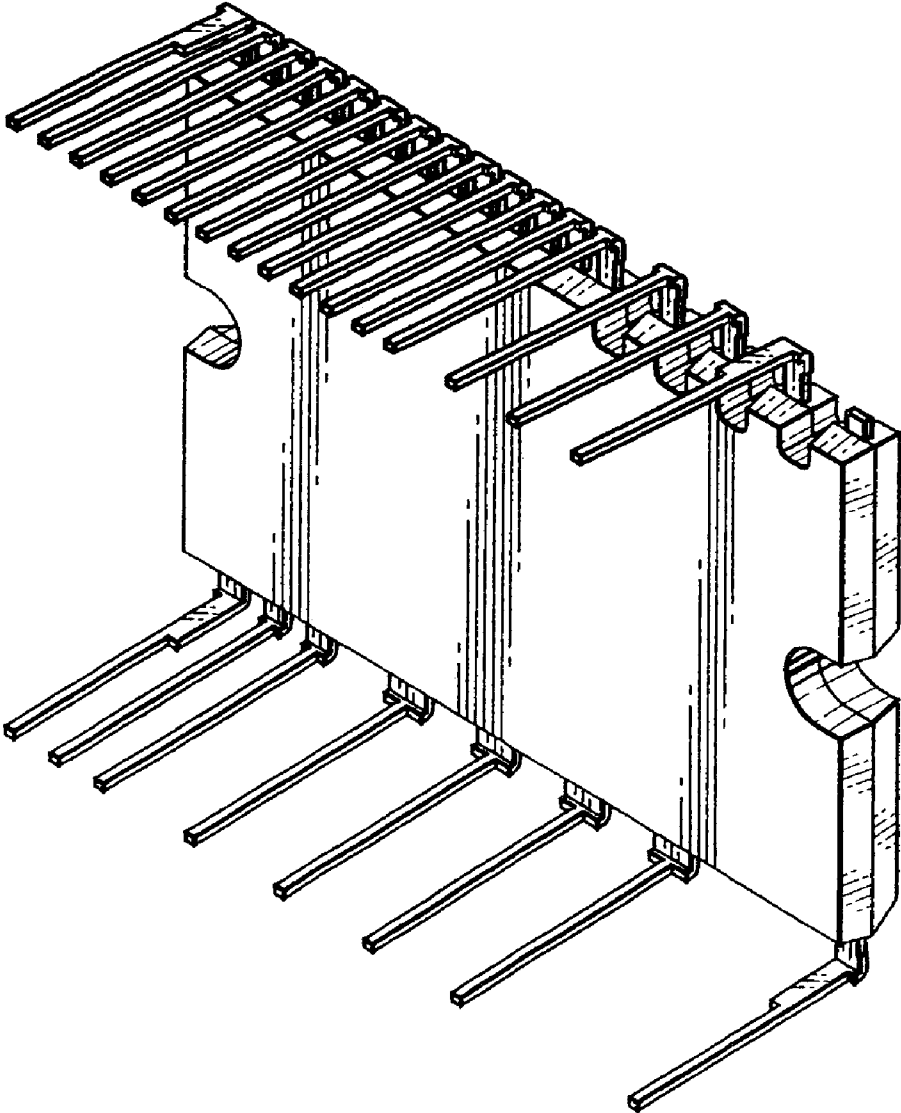

FIG.2

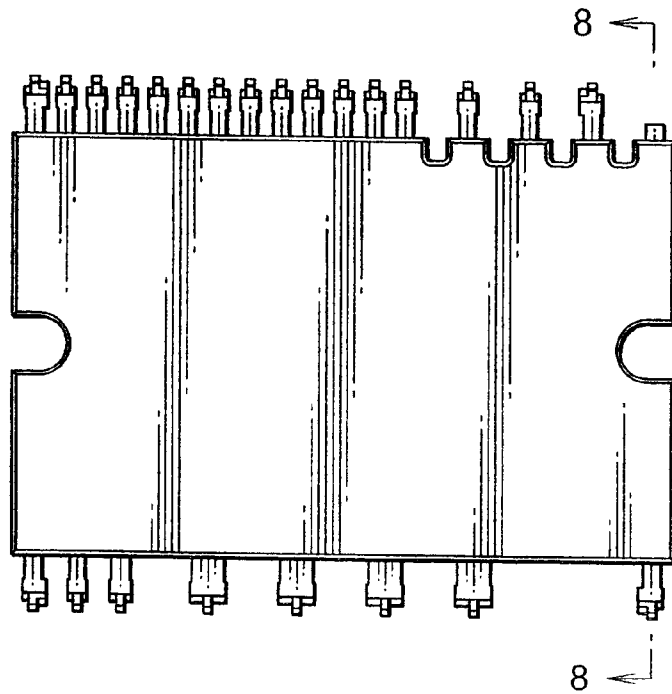

FIG.3

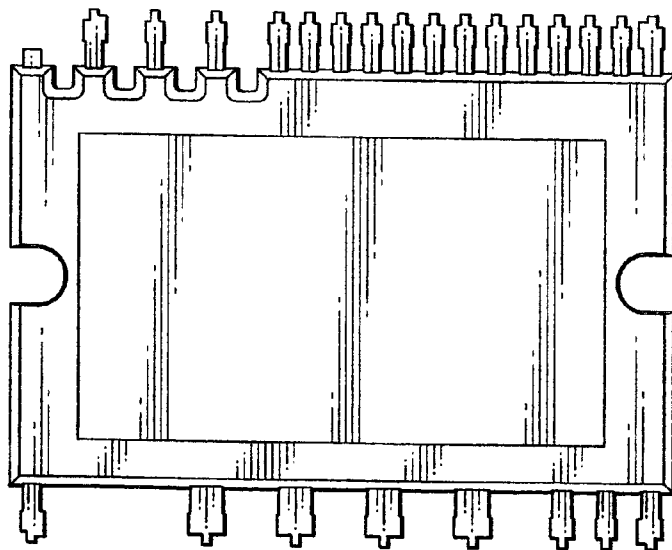

FIG. 4

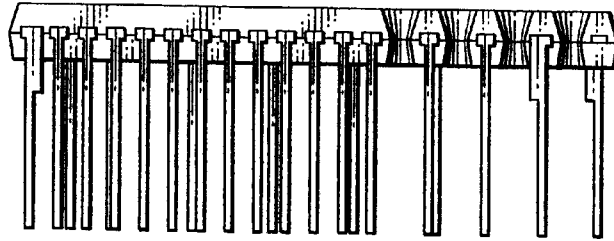

FIG. 5

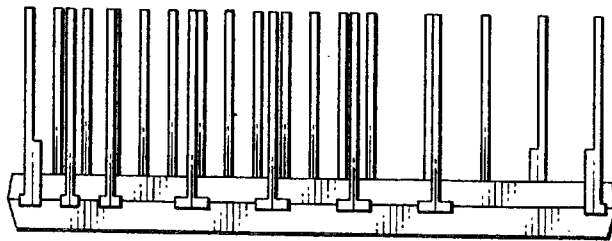

FIG. 6

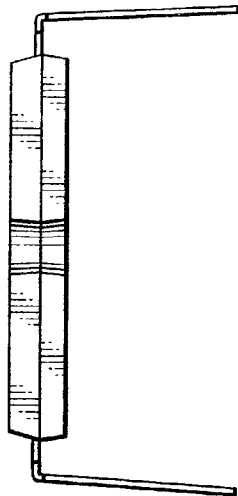

FIG. 7

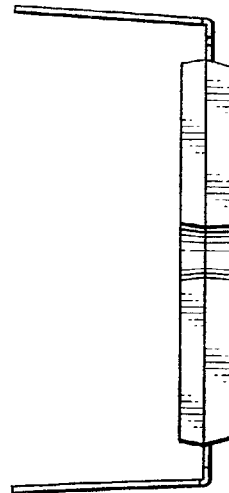

FIG. 8

