

(No Model.)

J. L. WHELPLEY.
SKATE.

No. 521,489.

Patented June 19, 1894.

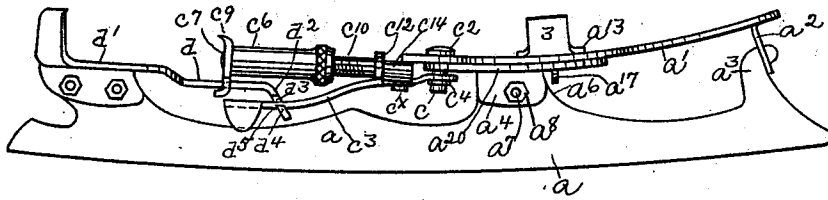

Fig. 1.

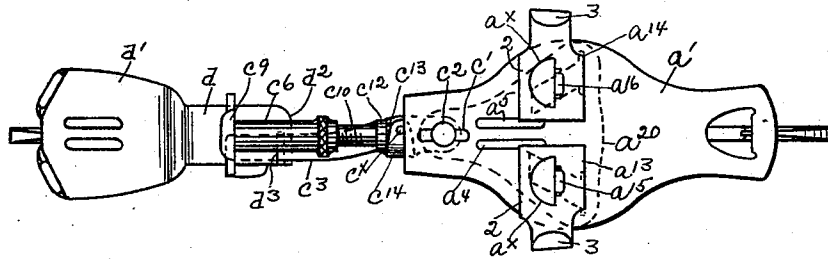

Fig. 2.

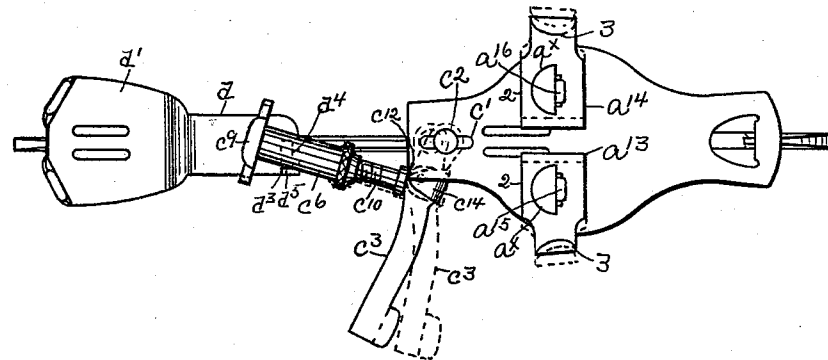

Fig. 3.

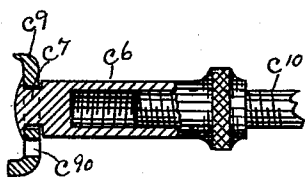

Fig. 5.

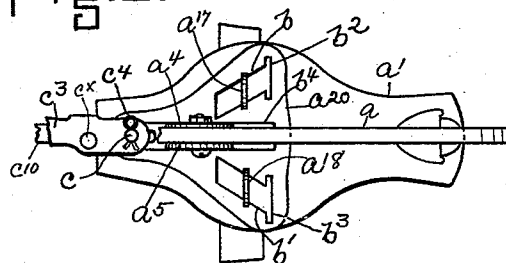

Fig. 4.

INVENTOR.

Joseph L. Whelpley

by Jas. H. Lehman

Atty.

WITNESSES.

Matthew M. Blunt

J. Murphy.

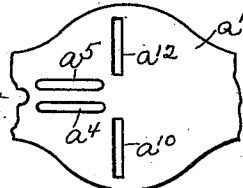

Fig. 6.

UNITED STATES PATENT OFFICE.

JOSEPH L. WHELPLEY, OF BOSTON, MASSACHUSETTS.

SKATE.

SPECIFICATION forming part of Letters Patent No. 521,489, dated June 19, 1894.

Application filed February 19, 1894. Serial No. 500,628. (No model.)

To all whom it may concern:

Be it known that I, JOSEPH L. WHELPLEY, a subject of the Queen of Great Britain, residing in Boston, in the county of Suffolk and State of Massachusetts, have invented an Improvement in Skates, of which the following description, in connection with the accompanying drawings, is a specification, like letters and numerals on the drawings representing like parts.

This invention relates to an improvement in boot or shoe appliances and is herein shown as embodied in a skate, which may be either ice or roller, and has for its object to provide a more efficient and durable skate in which the operating parts are positively operated both in applying the skate to and in removing it from the foot.

The invention is herein shown as embodied in that class of skates in which an operating lever is employed.

One feature of this invention consists in a novel construction and arrangement of the clamps, employed to grip the sole of the boot or shoe and commonly called toe clamps, and mechanism which operates the said clamps, whereby superior results may be obtained as will be hereinafter set forth.

My invention further consists in combination with the toe clamps and their actuating mechanism of an adjusting device, as will be described, capable of working under all conditions, and which is free from liability of derangement, rusting or freezing, and is reliable at all times to perform its duty.

The invention further consists in a novel combination and arrangement of the actuating lever and the parts operated by it, whereby the said lever can be closed and locked from any position into which it may have been turned in the adjustment of the skate to the boot or shoe.

The toe clamps are made detachable from the skate as will be described, so that they may be renewed or replaced substantially in an instant.

These and other features of this invention will be pointed out in the claims at the end of this specification.

Figure 1 is a side elevation of a skate embodying this invention, with the parts in their closed or operative position; Fig. 2, a top or

plan view of the skate shown in Fig. 1; Fig. 3, a top or plan view of the skate showing the parts in their open position ready to be fitted on the boot or shoe; Fig. 4, a detail of the under side of the front portion of the skate to more clearly show the toe clamp actuating cam plate; Fig. 5, a sectional detail of the adjusting device, and Fig. 6, a detail in plan of the upper side of the foot plate.

In the present instance, the invention is shown embodied in an ice skate provided with the runner a , which may be of any suitable construction and material, usually steel.

In accordance with this invention, the runner a has firmly secured to it a foot plate a' , herein represented as provided at its front end with a depending lip or lug a^2 adapted to engage an upright a^3 on the said runner, and the said foot plate is shown as provided at or near its rear portion with depending ears or lugs a^4 a^5 , (see Figs. 1 and 4,) between which is inserted an upright lug or portion a^6 on the runner a , the said ears and lugs being preferably fastened together by a screw bolt a^7 threaded at its end and engaged by a nut a^8 . The foot plate a' , in accordance with this invention is made plain and unbroken and may be either curved or flat as desired, and is provided with straight narrow slots a^{10} a^{12} (see Fig. 6) extended on opposite sides of and at substantially right angles to a line through the longitudinal center of the foot plate. The foot plate supports toe clamps a^{13} a^{14} , preferably made as herein shown, each clamp consisting of a flat portion 2 and an upright or lug 3 at its outer end, the said clamps having attached to or forming part of them respectively, depending arms, ears or pieces a^{15} a^{16} (see Figs. 2 and 3) which project downward through the slots a^{10} a^{12} in the foot plate, and are provided at their lower ends with enlargements, heads or buttons a^{17} a^{18} (see Figs. 1 and 4) for a purpose as will be described, the said enlargements in the present instance being shown as integral with the arms a^{15} a^{16} and struck out of the flat portions 2, which in the present instance leaves an opening a^x in the same.

In the present construction, the arms a^{15} a^{16} are rectangular in shape and are made substantially wide, to prevent side twisting or movement of the toe clamps on the foot

plate, and the said arms co-operate in accordance with this invention, with a clamp actuating device, shown as a substantially Y-shaped plate a^{20} (see Fig. 4) provided with 5 diverging straight slots or cam openings $b b'$ of substantially the same width of the arms $a^{15} a^{16}$, and having in the present instance enlargements $b^3 b^3$, preferably located at the ends of the slots $b b'$ and made of sufficient 10 size and suitable shape to permit the ready passage through them of the heads or enlargements $a^{17} a^{18}$, to thereby enable the toe clamps to be applied to and removed from the foot plate, which latter constitutes one part of the 15 skate frame. The heads or enlargements $a^{17} a^{18}$ are of such size as to prevent their passage through the cam slots $b b'$ and of sufficient size to extend beyond the sides of the said cam slots and engage the under side of the toe 20 clamp operating plate a^{20} , as represented in Fig. 4, to thereby firmly lock the toe clamps and their operating plate to the foot plate a' .

The clamp operating cam plate a^{20} , for the best results, is made of substantially the same 25 shape as the under surface of the foot plate, and the arms $a^{15} a^{16}$ are made of such length as to cause the said cam plate to be tightly held against the under side of the foot plate, when the heads $a^{17} a^{18}$ engage the said cam 30 plate, the toe clamps at such time being held close to the upper surface of the foot plate, so that danger of the skate becoming inoperative by reason of snow and ice getting between the foot plate and the toe clamps on 35 the upper surface and the cam plate on its under surface is avoided.

In the present construction, the cam plate a^{20} is provided with a longitudinal slot b^4 (see Fig. 4) to fit over the ears $a^4 a^5$, and which 40 permits movement of the cam plate a^{20} in a plane substantially parallel with the longitudinal center of the skate.

The clamp operating cam plate a^{20} is secured at its rear end to the foot plate by a 45 stud or pin c extended through a longitudinal slot c' in the rear portion of the foot plate, the said pin being provided with a lead c^2 , which rests upon and slides over the upper surface of the foot plate, the stud or pin c being 50 extended through a hole, in the rear end of the clamp operating plate a^{20} beyond the slot b^4 , and loosely through one end of an actuating lever c^3 , the said stud or pin being preferably secured to the skate by a cotter pin c^4 55 or other suitable device, which permits of its being removed when desired, but which will not work loose or become detached in use.

The actuating lever c^3 has connected to it, as will be described, an adjusting device, preferably of the construction herein shown and 60 consisting of a revolving socket c^6 , herein shown as tubular in form and made solid or closed at one end (see Fig. 5) and provided with a stem or projection c^7 , forming a journal on which the said socket revolves axially, 65 and which in the present construction of skate is shown as extended through a hole in

the heel knife c^9 , and loosely secured to the said heel knife by upsetting the end of the said stud or projection to form a loose rivet 70 connection.

The tubular socket c^6 is provided on its interior for the whole or a portion of its length, with screw threads, which are engaged by a 75 threaded rod c^{10} preferably of the construction as herein shown, it being provided at its outer end with a shoulder c^{12} and with an extension or finger c^{13} , which latter is loosely connected as by a pin or rivet c^x to the actuating lever c^3 and to a finger c^{14} of the said 80 lever extended from one side of the lever and bent over substantially at right angles to the length of the said lever as shown in Figs. 2 and 3. The tubular socket c^6 protects the threaded rod c^{10} from the action of water and 85 from the weather, so that the said tubular socket is free at all times and under all conditions to be quickly and easily rotated to move the threaded rod c^{10} into and out of its socket, and thereby effect an adjustment of 90 the heel knife when so desired.

The heel knife c^9 is preferably made with a transverse slot c^{20} in its lower portion (see Fig. 5) to enable the said knife to be fitted over an extension d of the heel plate d' , upon 95 which extension the said heel knife is free to be moved backward and forward when the actuating lever c^3 is operated.

The actuating lever c^3 is designed and adapted to engage a locking device, which in 100 the present instance is shown as a downwardly bent finger d^2 on the end of the heel plate extension, the said finger being provided with a transverse slot d^3 extending for a portion of the width of the finger and provided 105 with an enlargement represented by the dotted line in Fig. 1, and made in the lower part of the finger so as to form a pocket d^4 having an upright lug or projection d^5 , which acts as a lock to prevent the accidental 110 displacement or withdrawal of the actuating lever c^3 , from its pocket, the distance between the upper side of the lug d^5 and the upper side of the slot d^3 being substantially the same width and preferably a little wider than 115 the thickness of the actuating lever, which permits of the ready passage of the actuating lever through this space, and which lever by reason of its spring action falls into the pocket d^4 , and in the normal or locked 120 condition of the lever, the latter is substantially in line with the locking lug or projection d^5 and is prevented from being moved out of its receptacle until positively lifted by hand, to bring the lever opposite the entrance slot d^3 . 125

The locking finger or device d^2 is herein shown as secured to or forming part of the heel plate extension, but I do not desire to limit my invention in this respect as the said 130 finger might be attached to other stationary parts of the skate.

The threaded rod or member c^{10} of the adjusting device is provided with the shoulder

c^{12} , so that in the outward movement of the
 actuating lever c^3 in the arc of a circle, and
 in the forward movement of the adjusting rod
 c^{10} , the said shoulder will engage the foot plate
 5 or other stationary part of the skate, which
 forms a stop for the further movement of the
 adjusting rod c^{10} when the actuating lever c^3
 is moved outward still farther, and which en-
 gagement of the shoulder c^{12} with the foot
 10 plate acts to render the pin c^x , connecting the
 rod c^{10} to the actuating lever c^3 , as a fulcrum
 for the said actuating lever, so that on the
 further outward movement of the actuating
 lever c^3 from the full line position shown in
 15 Fig. 3 into its dotted line position in said
 figure, the cam actuating plate a^{20} is posi-
 tively moved through the connecting stud or
 pin c , in a straight backward path or direc-
 tion, that is, toward the heel of the skate, and
 20 in this backward movement of the cam oper-
 ating plate, the toe clamps are positively
 moved outward in a substantially straight
 line, by reason of the cam slots b b' being
 moved under the enlargements or heads a^{17}
 25 a^{18} on the arms of the toe clamps, which posi-
 tive movement of the toe clamps and its oper-
 ating plate is also effected when the actu-
 ating lever is brought into its closed position
 in engagement with the locking finger but in
 30 a reverse direction.

The forward movement of the toe clamp
 actuating plate a^{20} takes place after the heel
 knife is brought to a bearing against the heel
 of the boot or shoe, which renders the adjust-
 35 ing device practically stationary and makes
 the pivot or pin c^x a fulcrum for the actu-
 ating lever c^3 for the inward movement of the
 said lever, which inward movement causes
 the actuating lever c^3 to force the cam plate
 40 forward or toward the toe of the skate in a
 substantially straight line parallel with the
 longitudinal center of the skate.

By means of the enlargements b^2 b^3 of the
 cam slots in the cam actuating skate, and also
 45 by reason of the fact, that the stud or pin c
 can be readily removed by withdrawing the
 cotter pin c^4 from its hole, the toe clamps may
 be quickly and easily removed from the skate,
 and a new size or pair of clamps may be sub-
 50 stituted therefor; for by an inspection of Fig.
 4, it will be seen that when the pin c^4 is re-
 moved from the hole in its stud c , the latter
 can be withdrawn from engagement with the
 foot plate a' and the cam plate a^{20} , which
 55 leaves the latter free to be moved toward the
 heel of the skate or until the enlargements of
 the cam slots register with the heads or but-
 tons on the arms of the toe clamps, and when
 in this condition, the said toe clamps may be
 60 readily removed. The slot d^3 in the finger d^2
 extends only a portion of the width of the
 said finger, and the actuating lever c^3 is
 thereby prevented from being forced beyond
 its correct closed position, so that all danger
 65 of springing of the parts of the skate oper-
 ated by said lever is avoided.

In the present embodiment of this inven-

tion, I have shown the same as incorporated
 in an ice skate having a movable heel knife,
 but I do not desire to limit my invention in
 70 this respect, as the toe clamps and its operat-
 ing device may be embodied in other forms
 of skates, as for instance, in ladies' skates,
 wherein the heel knife is dispensed with, and
 wherein the adjustable socket may be loosely
 75 riveted to the stationary heel or to a station-
 ary part attached to the heel plate. Further-
 more, the construction of skate herein shown
 is equally well adapted for use in roller
 80 skates.

The advantages of a skate embodying the in-
 vention herein shown may be briefly summed
 up as follows:—The toe clamps cannot get
 loose, twist sidewise, or pull up from the foot
 85 plate in the most severe usage, and rattling
 and sagging of the clamps is absolutely avoid-
 ed, while exceptional strength of grip is ob-
 tained. Furthermore, the toe clamps are
 positively operated in opposite directions,
 whereby the parts cannot become clogged or
 90 bound, and perfect freedom of action is se-
 cured under all conditions, without the ne-
 cessity of the operator touching any part of
 the skate except the actuating lever. Fur-
 thermore, the socket adjusting device being
 95 loosely riveted, can be quickly and easily re-
 volved in either direction upon the screw rod
 c^{10} , which latter works in its socket and is
 protected from rust and from being bound by
 the wet or weather, and cannot freeze up, and
 100 furthermore, a long support is afforded for
 the screw rod, which greatly strengthens the
 adjusting device and reduces to a minimum
 the danger of the rod being bent or becoming
 105 deranged.

The locking device for the actuating lever
 prevents sagging of the same and the parts
 operated by it, thereby protecting the user
 from accidents which might arise by the ac-
 110 cidental loosening of the skate due to the
 sagging of these parts while in motion or use.

Another feature of the arrangement and
 combination of parts herein shown is, that
 the adjusting devices cannot be brought into
 such position as will prevent the lever being
 115 closed from the most open position of the le-
 ver, thereby avoiding danger of the breaking
 of parts of the skate, by reason of the same
 becoming cramped when the lever is open,
 which is liable to occur in skates employing
 120 an actuating lever and known to me.

I have herein shown the invention as em-
 bodied in a skate but it may be used in other
 appliances of similar nature, and which are
 attached to the boot or shoe, such for in-
 125 stances, skees, snow shoes, &c.

I claim—

1. In a skate, the combination of the follow-
 ing instrumentalities, viz:—a foot plate hav-
 ing an unbroken surface and provided with
 130 straight slots extended substantially at right
 angles to the longitudinal center of the foot
 plate on opposite sides of said longitudinal
 center, toe clamps resting directly upon the

unbroken surface of the foot plate arms attached to the said toe clamps and extended down through the said slots, enlargements on said arms and a cam plate located on the under side of the foot plate and provided with inclined slots or ways having enlargements and co-operating with the said depending arms on the toe clamps, an actuating lever to move said cam plate, a heel knife, and an adjusting device loosely connected to the heel plate and to the actuating lever, substantially as described.

2. In a skate, the combination of the following instrumentalities, viz:—a foot plate provided with straight slots extended substantially at right angles to the longitudinal center of the foot plate, toe clamps resting directly upon the foot plate and provided with arms extended down through the said slots, and having enlargements at their ends a cam plate provided with inclined slots or ways having enlargements and co-operating with the said depending arms on the toe clamps, an actuating lever to move said cam plate, a heel knife, an adjusting device loosely connected to the heel knife and to the actuating lever, and a locking device for the said actuating lever attached to and depending from the heel plate, substantially as described.

3. In a skate, the combination with a foot plate provided with straight slots toe clamps resting on the upper surface of the foot plate and provided with arms having enlargements or heads, of a cam actuating plate located on the under side of the foot plate and provided with diverging cam slots to engage the said arms and effect the movement of the toe clamps and enlarged openings in the cam plate communicating with the cam slots and adapted to permit of the passage through them of the enlargements on the toe clamp arms, substantially as described.

4. In a skate, the combination of the following instrumentalities, viz:—a foot plate provided with straight, narrow slots extending entirely through the foot plate substantially at right angles to the longitudinal center of the same, toe clamps resting directly upon the upper surface of the foot plate and provided with substantially wide other-than-round arms extending down through the said slots, enlargements on said arms, a cam plate in contact with the under side of the foot plate and provided with diverging cam slots having enlargements to receive the enlargements on the arms of the toe clamps, and means to operate said cam plate, substantially as described.

5. In a skate, the combination of the following instrumentalities, viz:—a foot plate provided with straight, narrow slots extending entirely through the foot plate substantially at right angles to the longitudinal center of the same, toe clamps resting directly upon the upper surface of the foot plate and provided

with substantially wide other-than-round arms extending down through the said slots, enlargements on said arms, a cam plate in contact with the under side of the foot plate and provided with diverging cam slots having enlargements to receive the enlargements on the arms of the toe clamps, an actuating lever loosely connected to said cam plate, a threaded rod pivotally connected to said lever, an internally threaded socket into which said threaded rod is extended, closed at one end and provided with a journal or extension upon which said socket rotates axially, and a bearing for said journal, substantially as described.

6. In a skate, the combination of the following instrumentalities, viz:—a foot plate provided with straight, narrow slots extending entirely through the foot plate substantially at right angles to the longitudinal center of the same, toe clamps resting directly upon the upper surface of the foot plate and provided with substantially wide other-than-round arms extending down through the said slots, enlargements on said arms, a cam plate in contact with the under side of the foot plate and provided with diverging cam slots having enlargements to receive the enlargements on the arms of the toe clamps, an actuating lever loosely connected to said cam plate, a threaded rod pivotally connected to said lever, an internally threaded socket into which said threaded rod is extended, closed at one end and provided with a journal or extension upon which said socket rotates axially, and a bearing for said journal, and an enlargement on the front end of the said threaded rod to engage the foot plate, substantially as described.

7. In a skate, the combination of the following instrumentalities, viz:—a foot plate provided with substantially straight slots extended on opposite sides of the longitudinal center of the foot plate substantially at right angles to said longitudinal center, toe clamps consisting of flat portions 2 having uprights or lugs 3 and depending arms struck out of the flat portion and depending from substantially the longitudinal center of the flat portion 2 of the toe clamp, the said arms being extended down through the slots in the foot plate and provided with enlargements or heads, a cam plate on the under side of the foot plate in contact with the bottom of the foot plate and provided with diverging cam slots to engage the depending arms on the toe clamps and means to operate the said cam plate, substantially as described.

In testimony whereof I have signed my name to this specification in the presence of two subscribing witnesses.

JOSEPH L. WHELPLEY.

Witnesses:

JAS. H. CHURCHILL,
J. MURPHY.