

J. MAROUSCH.
EXCAVATING, HOISTING, AND CONVEYING BUCKET.

APPLICATION FILED SEPT. 28, 1904.

4 SHEETS—SHEET 1.

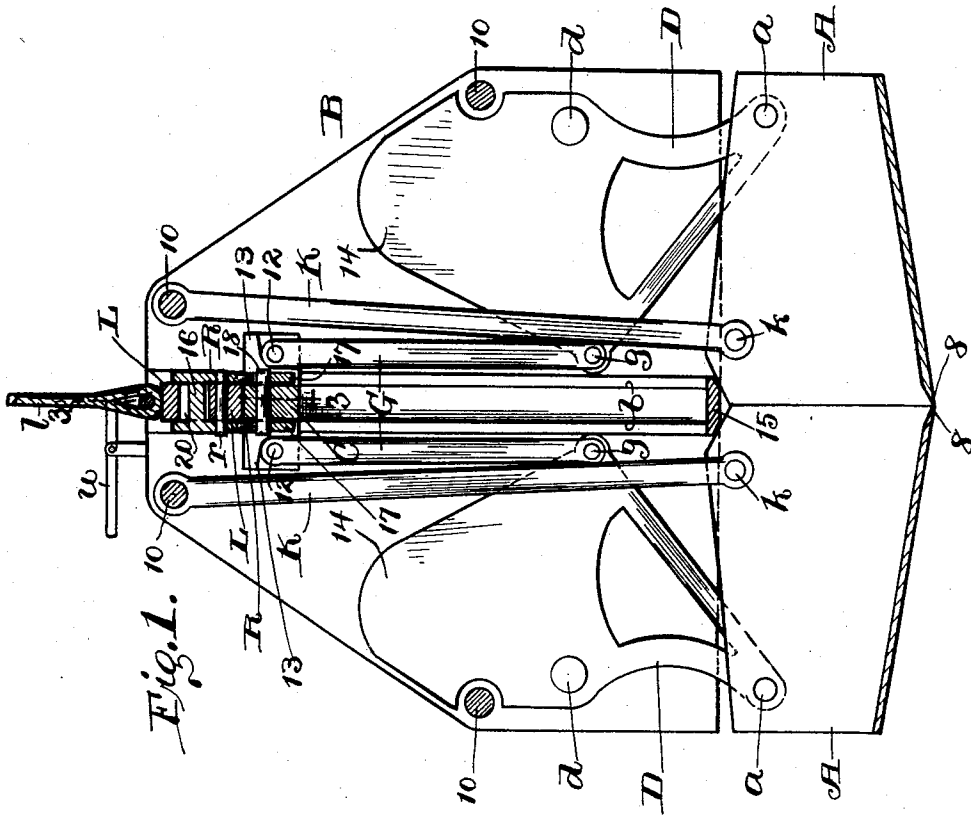
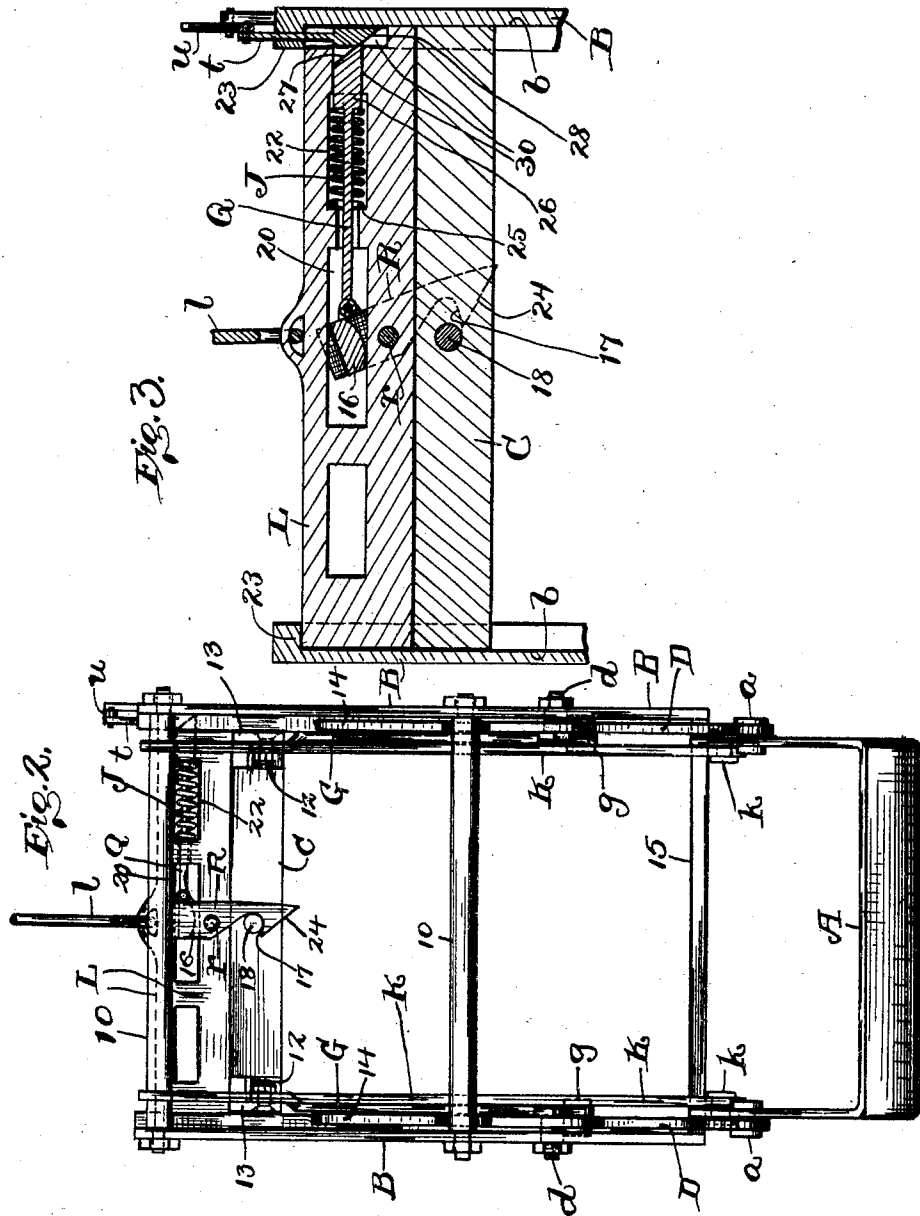

Fig. 1.

WITNESSES:
Daniel E. Daly.
B. G. Brown.

INVENTOR
Joseph Marousch
BY
Symonds & Sons
ATTORNEYS

J. MAROUSCH.
EXCAVATING, HOISTING, AND CONVEYING BUCKET.
APPLICATION FILED SEPT. 28, 1904.



WITNESSES:
Daniel E. Daly.
B. C. Brown.

INVENTOR
Joseph Marousch
BY
S. M. Brown
ATTORNEYS

J. MAROUSCH.
EXCAVATING, HOISTING, AND CONVEYING BUCKET.

APPLICATION FILED SEPT. 28, 1904.

4 SHEETS—SHEET 3.

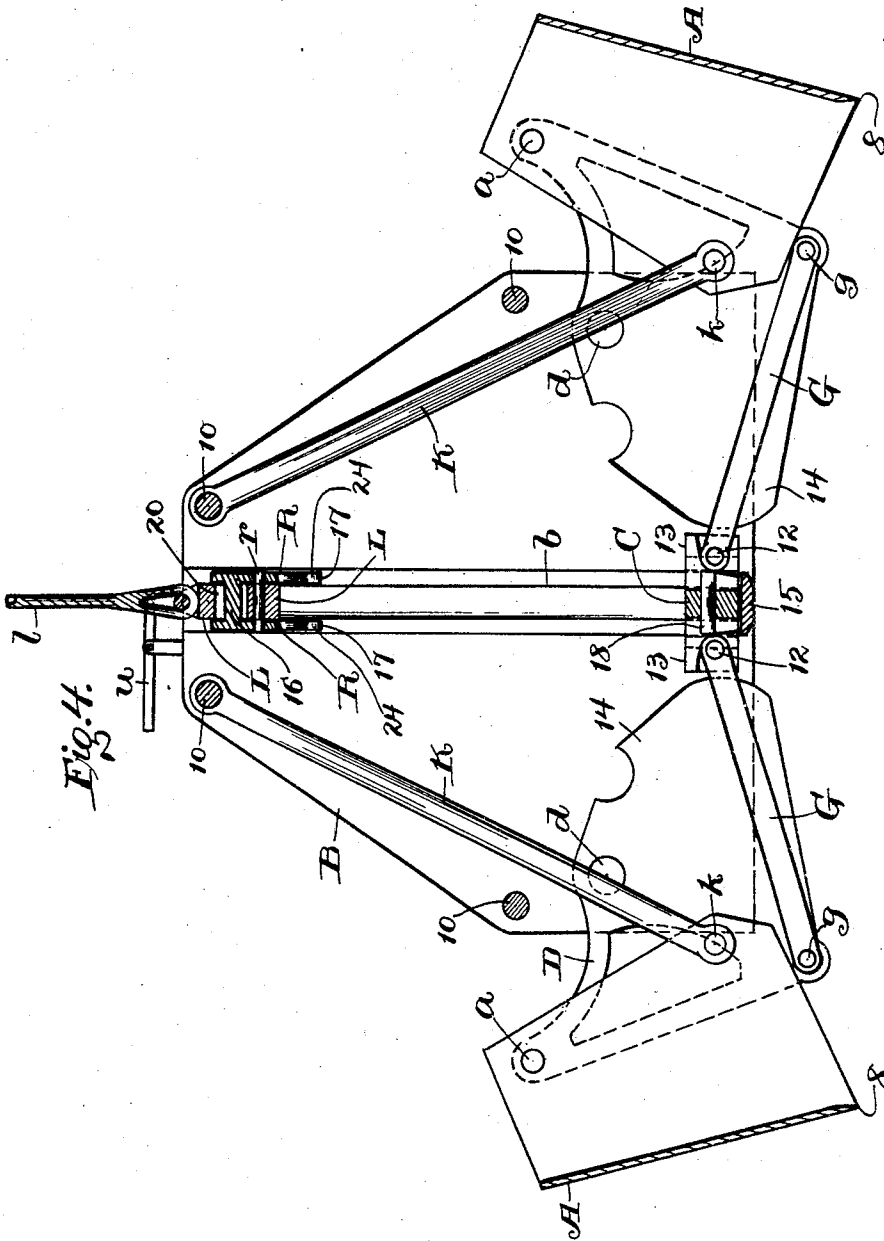

Fig. 4.

WITNESSES:
Raniel E. Daly.
B. G. Brown.

INVENTOR
Joseph Marousch
 BY
Spencer & Brown
 Attorneys

J. MAROUSCH.
EXCAVATING, HOISTING, AND CONVEYING BUCKET.

APPLICATION FILED SEPT. 28, 1904.

4 SHEETS—SHEET 4.

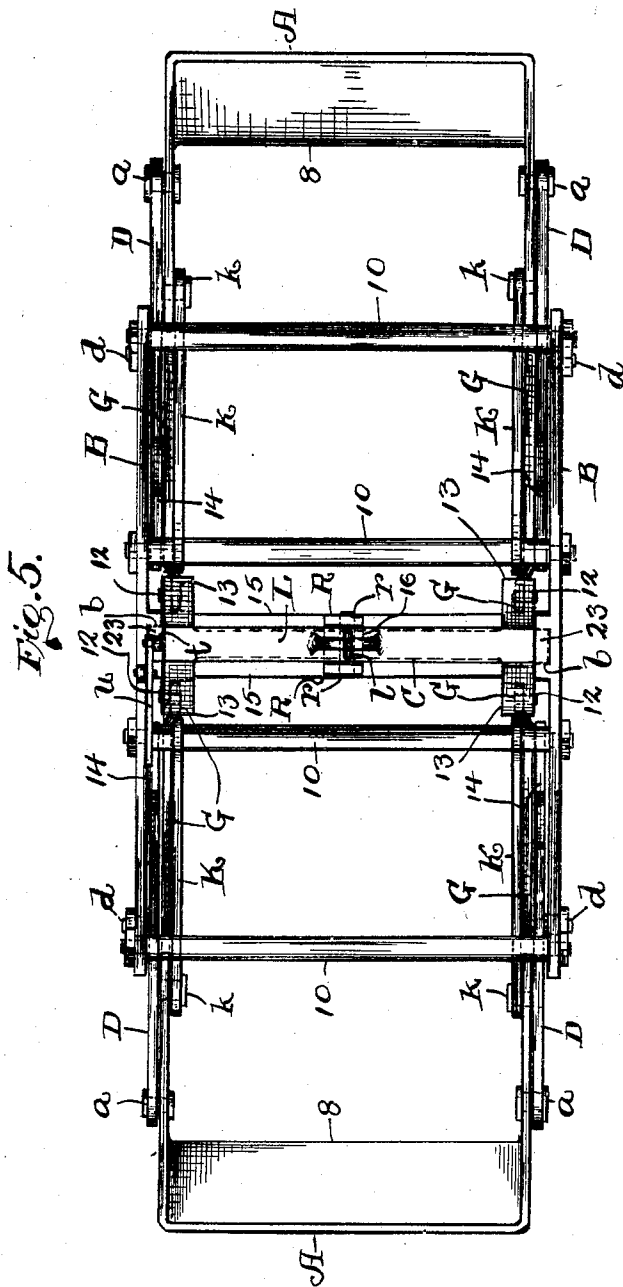

FIG. 5.

WITNESSES:
Daniel E. Daly.
B. C. Brown

INVENTOR
Joseph Marousch
 BY
Spencer Brown
 HIS ATTORNEYS

UNITED STATES PATENT OFFICE.

JOSEPH MAROUSCH, OF CLEVELAND, OHIO.

EXCAVATING, HOISTING, AND CONVEYING BUCKET.

SPECIFICATION forming part of Letters Patent No. 782,864, dated February 21, 1905.

Application filed September 28, 1904. Serial No. 226,333.

To all whom it may concern:

Be it known that I, JOSEPH MAROUSCH, a citizen of the United States of America, residing at Cleveland, in the county of Cuyahoga and State of Ohio, have invented certain new and useful Improvements in Excavating, Hoisting, and Conveying Buckets; and I hereby declare the following to be a full, clear, and exact description of the invention, such as will enable others skilled in the art to which it pertains to make and use the same.

This invention relates to improvements in excavating, hoisting, and conveying buckets, and pertains more especially to a clam-shell bucket well adapted for use in loading and unloading vessels and comprising two oppositely-arranged trays having cutting edges at the bottom and forward or inner ends and pivotally supported, as required to render them capable of being swung from and toward each other to open and close the bucket, respectively.

One object of this invention is to avoid the requirement of more than one cable for the closing and hoisting and lowering of the bucket.

Another object is to provide the bucket with a vertically-movable slide arranged centrally of the bucket and parallel with the axes of the trays, which slide in the closed position of the trays is in its upper position a suitable distance above the forward or inner ends of the trays and detachably connected with the means employed in elevating the slide.

Another object is to have the said slide perform the function of a weight acting to separate the trays, and thereby open the bucket when the slide is detached from the hoisting means.

Another object is to so connect the trays with the relatively stationary framework of the bucket and to provide such an operative connection between each tray and the aforesaid slide that the two trays are swung from or toward each other to open or close the bucket, respectively, according as the slide is released and permitted to drop by gravity or actuated into its upper position.

Another object is to provide such an ar-

range of the parts employed in supporting and actuating the trays that the employment of more than one cable for closing and elevating and lowering the bucket is not only not required, but upward movement of the forward and cutting edges of the trays during the actuation of the trays from their open into their closed position is avoided, so that an advantageous operation of the trays upon a pile or bed of material to be operated upon by the trays is insured.

Another object is to provide a clam-shell bucket which not only operates advantageously, but is reliable in its operation and simple and durable in construction.

With these objects in view this invention consists in certain features of construction and combinations of parts hereinafter described, and pointed out in the claims.

In the accompanying drawings, Figure 1 is a side elevation, largely in central section, of a clam-shell bucket and connected tray-swinging mechanism embodying my invention, and in this figure the bucket is shown closed. Fig. 2 is a right-hand side elevation relative to Fig. 1. Fig. 3 is an elevation, largely in vertical section, on line 3 3, Fig. 1, looking in the direction indicated by the arrow, except that in Fig. 3 the lever-connecting slide is shown released preparatory to its descent by gravity. Fig. 4 is a side elevation, largely in central section, of the bucket and tray-swinging mechanism, and in this figure the bucket is shown open. Fig. 5 is a top plan relative to Fig. 4. Fig. 3 is drawn on a larger scale than the remaining figures.

Referring to the drawings, A and A indicate the two oppositely-arranged trays of my improved clam-shell bucket. The trays A swing from or toward each other, according as the bucket is opened or closed. The bucket illustrated is shown closed in Figs. 1 and 2 and open in Figs. 4 and 5.

The relatively stationary framework employed in supporting the trays A and the tray-swinging mechanism comprises two parallel plates B and B, arranged vertically at opposite sides, respectively, of and extending a suitable distance above the sweep of the trays, and a horizontally-arranged slide C extends

between and is arranged at a right angle to the plates B centrally between the side edges of the said plates and capable of movement vertically, engaging vertically-arranged slide-way-forming recesses *b*, with which the said plates B are provided at their inner sides and centrally between their side edges.

The plates B are tied together and braced apart by suitably-applied rods 10, which extend horizontally between and are rigid with the said plates, which rods are parallel with the slide C.

Each tray A is horizontally pivoted at its rear end and near the top thereof, as at *a*, to a pair of swingable plates D, forming bell-crank levers and arranged to oscillate in a vertical plane at opposite sides, respectively, of the said tray, and the said levers D are fulcrumed, as at *d*, horizontally and parallel with the axes of the said tray to the plates B between the central portion and lower edge of the said plates and a suitable distance from the pivotal connections *a* between the said tray and the said levers. Each tray A is provided at the forward or inner end of its bottom with a cutting edge 8.

The arrangement of the parts is such that in the closed position of the bucket, as shown in Figs. 1 and 2, each lever D has one of its arms depending below the axis of the lever and pivoted at its lower end, as at *a*, as already indicated, to the connected tray, and the other arm of the said lever projects inwardly to a link G, which is pivoted at one end, as at *g*, to the last-mentioned lever-arm horizontally and parallel with the axis of the lever and pivoted at its other end, as at *l*, horizontally and parallel with the said axis to a lug 13, formed on and projecting laterally and outwardly from the adjacent side of the slide C.

Each tray A is suspended at its forward end and near the top from the upper ends of the plates B by two bars or links K, arranged at opposite sides, respectively, of the tray. The said links K are pivoted to the said tray, as at *k*, and to the plates B, and the pivotal connections between the links K and the plates B are arranged horizontally and parallel with the axes of the levers D. Preferably the pivotal connections between the links K and the plates B are formed by two of the rods 10, instrumental, as already indicated, in connecting the plates B together. It will be observed, therefore, that each tray A is suspended at its forward end by means of two bars or links K, depending from and pivoted at their upper ends to the plates B of the relatively stationary framework of the bucket, which links are pivoted at their lower ends to the said trays, and that the said tray is operatively connected at its rear end, through the medium of two bell-crank levers D, which are supported from the aforesaid framework, with links pivotally attached to the slide C, and the arrangement

of the parts is such that in the closed position of the bucket the point of attachment of each bell-crank lever D to the tray to which the said lever is attached is arranged vertically or approximately vertically below the fulcrum of the said lever, and that the pivotal attachment to the slide C of the link G, operatively connecting the said lever with the said slide, is arranged inwardly from the aforesaid fulcrum a distance equal or approximately equal to the distance between the said fulcrum and the point of attachment of the said lever to the tray, and that also when the bucket is closed the links G and K are arranged vertically or approximately vertically and the slide C is in its upper position a suitable distance above the fulcrums of the levers D and releasably held in its said position, as will hereinafter appear.

Each tray-swinging lever D is weighted, as at 14, between the fulcrum of the lever and the slide C by the extension of the plate which forms the said lever in the direction of the said slide, and the weights 14 of the levers D, as well as the weight of the slide C, act to retain the trays A in their open position.

By the construction and arrangement of parts hereinafter described it will be observed that when the slide C is in its upper position, as shown in Figs. 1 and 2, the trays are in their inwardly-swung and closed position; that a release of the said slide from the means employed in holding it elevated results in the dropping of the slide by gravity and in the actuation of the bell-crank levers D by the action of the weights 14, connected with the said levers, and by the weight of the said slide in the direction required to swing the trays apart, and thereby open the bucket; that the cutting edges 8 of the trays move only inwardly and downwardly during the closing of the bucket, and consequently by my improved bucket a pile or bed of material to be operated upon can be completely and cleanly excavated or removed.

The slide C in its lower position when the bucket is open rests upon a cross-bar 15, which extends between the lower ends of the plates B at the lower ends of the slideways *b* and connects the said plates B together, as shown in Figs. 1, 2, and 4. The cross-bar 15 forms a stop, therefore, to limit the descent of the slide C, and thereby limit the swinging of the trays during the actuation of the trays into their outer and open position.

The means for elevating the slide C into its upper position, as required to actuate the bell-crank levers D in the direction required to swing the trays from their outer and open into their inner and closed position, comprises, preferably, a vertically-movable slide L, arranged horizontally above and parallel with the slide C. The upper slide L extends, therefore, between and at a right angle to the plates B above the lower slide C and centrally be-

tween the side edges of the said plates and engages at its ends with the slideway-forming recesses *b*.

The upper slide L is provided centrally between its ends with two hooks R, arranged at opposite sides, respectively, of the said slide. The hooks R are pivoted, as at *r*, to the slide L horizontally and at a right angle to the travel of the said slide. The hooks R are connected by a web 16 and have their bills or beaks 17 arranged to overlap and engage the under sides of the ends of a round pin 18, which extends through and beyond opposite sides of the slide C centrally between the ends of the said slide. The slide L is slotted laterally, as at 20, to accommodate the location of the web 16 of the hooks R.

A suitably-applied spiral spring J acts to retain the hooks R in their operative position and is preferably confined, as will hereinafter more clearly appear, within and arranged longitudinally of the slide L, which is slotted laterally, as at 22, to accommodate the location and operation of the said spring.

The slideway-forming recesses *b* have upper end walls 23, which are arranged to form stops to limit the upward movement of the slide L.

A cable *l*, employed in elevating and lowering the bucket and employed also in closing the bucket, is attached in any approved manner to the upper slide L centrally between the ends of the said slide.

The hooks R are provided at their lower ends with inclines 24, arranged to engage the pin 18 of the slide C upon lowering the hook-bearing slide L to bring the hooks R into operative engagement with the said pin. The engagement of the inclines 24 with the pin 18 acts to swing the hooks against the action of the spring J; but as soon as the beaks 17 of the hooks descend below the pin 18 during the lowering of the hook-bearing slide the hooks are swung by the action of the spring J to bring their beaks 17 in under the pin 18, and thereby render the hooks operative.

The pin 18 and the hooks R are instrumental in detachably connecting the slide C to the slide L. In Figs. 1 and 2 the slide C is shown attached to the slide L. In Fig. 3 the pin 18, and consequently the slide C, is shown released from the hooks R preparatory to the descent of the said slide into its lower position, and in Fig. 4 the said slide is shown in its lower position, with the bucket open, and the bucket is also shown open in Fig. 5.

The spring J is preferably mounted upon an endwise-shiftable bar Q, which is arranged within and longitudinally of the hook-bearing slide L at one side of the web 16 of the hooks R and extends from the said web to one of the slideways *b*. The spring J is confined upon the bar Q between an annular shoulder 25, with which the slide L is interiorly provided, and the inner end of a head 26, formed

upon the outer end of the said bar, which head has bearing in the said slide, as shown very clearly in Fig. 3. The outer end of the head 26 is beveled, so as to form an upward-facing inclined surface 27, which is engaged by a correspondingly-inclined surface 28, formed upon the lower end of a vertically-arranged bar *t*, which extends through and has bearing in the top wall 23 of the adjacent recess *b* and is operatively connected at its upper end with a suitably-operated lever *u*, with which the relatively stationary framework is provided.

The slide L is slotted or cut away, as at 30, to accommodate the location and operation of the engaging end portions of the bars Q and *t*.

By the construction and arrangement of the parts hereinbefore described it will be observed that the mechanism for rendering the hooks R inoperative is in the main contained within the slide L, which is slotted, therefore, wherever required to accommodate the location and operation of the said mechanism, and it will be observed that a downward movement of the bar *t* by actuating the lever *u* in the required direction shifts the bar Q inwardly against the action of the spring J and swings the hooks R in the required direction to render them inoperative; that when the bucket is closed the slide C is in its elevated position, detachably connected by the hooks R and pin 18 to the slide L; that preparatory to the opening of the bucket the slide C is disconnected from the slide L by rendering the hooks R inoperative, whereupon the weight of the slide C and the weights 14 of the connected bell-crank lever operate to open the bucket, as already hereinbefore indicated; that the slide C when the bucket is opened rests upon the cross-bar 15, and that the slide L is again lowered and detachably connected to the slide C preparatory to the next closing of the bucket.

What I claim is—

1. In a bucket comprising two trays arranged to swing from and toward each other according as the bucket is opened or closed, the combination, with the said trays; relatively stationary framework comprising two plates arranged at opposite sides respectively and extending above the sweep of the trays and suitably connected together, which plates are provided at their inner sides and centrally between their side edges with upright slideways, and upright links pivotally attached at their lower ends to the forward or inner portions of the trays and at their upper ends to the aforesaid plates, of bell-crank levers fulcrumed to the said plates and operatively connected with the trays at the rear ends of the trays; a slide arranged centrally and transversely of the bucket and engaging the aforesaid slideways, which slide constitutes a weight and is provided with laterally-projecting lugs; links pivotally attached at one end to the bell-crank levers and at the other end to the said

lugs; means for elevating the slide; means for detachably connecting the slide to the slide-elevating means, and means for limiting the descent of the slide, and the arrangement of the parts being such that the trays are swung outwardly or inwardly according as the slide moves into its lower or upper position.

2. In a bucket comprising trays arranged to swing from and toward each other according as the bucket is opened or closed, the combination, with the said trays; relatively stationary framework comprising two plates arranged at opposite sides respectively and extending above the sweep of the trays and suitably connected together, which plates are provided at their inner sides and centrally between their side edges with upright slideways, and upright links pivotally attached at their lower ends to the forward or inner portions of the trays and at their upper ends to the aforesaid plates, of bell-crank levers fulcrumed to the said plates and operatively connected with the trays at the rear ends of the trays, which levers are weighted for actuating them in the direction required to swing the trays outwardly; a slide arranged centrally and transversely of the bucket and engaging the aforesaid slideways; links pivotally attached at one end to the bell-crank levers and at the other end to the slide; means for elevating the slide; means for detachably connecting the slide to the slide-elevating means, and means for limiting the descent of the slide.

3. In a bucket comprising trays arranged to swing outwardly and upwardly or inwardly and downwardly according as the bucket is opened or closed, the combination, with the said trays; relatively stationary framework extending above the sweep of the trays and provided with upright slideways, and upright links pivotally attached at their lower ends to the forward or inner portions of the trays and at their upper ends to the aforesaid framework, of bell-crank levers fulcrumed to the said framework and operatively connected with the trays at the rear ends of the trays; a slide arranged centrally and transversely of the bucket and engaging the aforesaid slideways; links pivotally attached at one end to the bell-crank levers and at the other end to the slide; means for elevating the slide; means for detachably connecting the slide to the slide-elevating means, and means for limiting the descent of the slide.

4. In a bucket comprising trays arranged to swing outwardly and upwardly or inwardly and downwardly according as the bucket is opened or closed, the combination, with the said trays; relatively stationary framework extending above the sweep of the trays, and upright links instrumental in suspending the trays from the said framework and pivotally connected at their lower ends to the forward or inner portions of the trays and at their upper ends to the said framework, of bell-crank le-

vers fulcrumed to the said framework and operatively connected with the trays at the rear ends of the trays; a suitably-guided member movable up and down centrally of the bucket and provided with laterally-projecting lugs, and links pivotally attached at one end to the bell-crank levers and at the other end to the said lugs.

5. In a bucket comprising trays arranged to swing outwardly and upwardly or inwardly and downwardly according as the bucket is opened or closed, the combination, with the said trays; relatively stationary framework extending above the sweep of the trays and provided with upright slideways, and links instrumental in suspending the trays from the stationary framework, of bell-crank levers fulcrumed to the said framework and operatively connected with the trays at the rear ends of the trays, which levers are weighted for actuating them in the direction required to swing the trays outwardly; a slide constituting a weight acting to actuate the bell-crank levers in the direction required to swing the trays outwardly and engaging the aforesaid slideways; links operatively connecting the bell-crank levers with the slide; means for hoisting the slide; means for detachably connecting the slide to the slide-hoisting means, and means for limiting the descent of the slide.

6. In a bucket comprising trays arranged to swing outwardly and upwardly or inwardly and downwardly according as the bucket is opened or closed, the combination, with the said trays; relatively stationary framework extending above the sweep of the trays and provided with upright slideways, and links instrumental in suspending the trays from the said framework, of bell-crank levers fulcrumed to the said framework and operatively connected with the trays at the rear ends of the trays; a slide engaging the aforesaid slideways; a hoisting-cable; means for detachably connecting the slide with the cable; means whereby the trays are swung outwardly or inwardly according as the slide moves downwardly or upwardly, and means acting to retain the trays in their outwardly-swung and open position.

7. In a bucket comprising trays arranged to swing outwardly and upwardly or inwardly and downwardly according as the bucket is opened or closed, the combination, with the said trays; relatively stationary framework extending above the sweep of the trays and provided with upright slideways, and upright links pivotally attached at their lower ends to the forward or inner portions of the trays and at their upper ends to the aforesaid framework, of bell-crank levers fulcrumed to the said framework and pivoted to the trays at the rear ends of the trays; a slide engaging the aforesaid slideways; links pivotally connected at one end to the bell-crank levers and at the other end to the slide; a hoisting-cable;

means for detachably connecting the slide to the cable, and means acting to retain the trays in their outwardly-swung and open position, and the arrangement of the parts being such that when the bucket is closed the axis of the pivotal connection between each bell-crank lever and the tray attached to the said lever shall be vertically or approximately vertically below the fulcrum of the lever and the axis of the pivotal connection between the said lever and the connected slide shall be horizontally or approximately horizontally inwardly from the fulcrum of the lever.

8. In a bucket comprising trays arranged to swing outwardly and upwardly or inwardly and downwardly according as the bucket is opened or closed, the combination, with the said trays; relatively stationary framework extending above the sweep of the trays, and upright links pivotally attached at their lower ends to the forward or inner portions of the trays and at their upper ends to the aforesaid framework, of bell-crank levers fulcrumed to the said framework and operatively connected with the trays at the rear ends of the trays; means for actuating the levers in the direction required to swing the trays from their outer and open position into their inner and closed position; a hoisting-cable: means for detachably connecting the aforesaid lever-operating means with the cable, and means acting to retain the trays in their outwardly-swung and open position.

9. In a bucket comprising trays having cutting edges at the forward ends of their bottoms and arranged to swing outwardly and upwardly or inwardly and downwardly according as the bucket is opened or closed, the combination, with the said trays; relatively stationary framework extending above the sweep of the tray, and upright links pivotally attached at their lower ends to the forward or inner portions of the trays and at their upper ends to the aforesaid framework, of bell-crank levers fulcrumed to the said framework and operatively connected with the trays at the rear ends of the trays; means for actuating the levers in the direction required to swing the trays from their outer and open position into their inner and closed position, which levers are weighted for actuating them in the opposite direction, and means for detachably connecting the aforesaid lever-operating means with the cable, and the arrangement of the parts being such that the cutting edges of the bucket move only downwardly and inwardly during the closing of the bucket.

10. In a bucket comprising two trays arranged to swing from and toward each other according as the bucket is opened or closed, the combination, with each tray; relatively stationary framework; and two upright links arranged at opposite sides respectively of the said tray and pivotally attached at its lower end to the forward or inner portion of the

tray and at its upper end to the framework, of two bell-crank levers fulcrumed to the said framework and arranged at opposite sides respectively of the said tray and operatively connected with the tray at the rear end of the tray; means for actuating the said levers simultaneously and in the direction required to swing the said tray from its outer and open position into its inner and closed position; a single cable for closing and hoisting and lowering the bucket; means for detachably connecting the aforesaid lever-actuating means with the cable, and means acting to retain the trays in their outwardly-swung and open position.

11. In a bucket comprising two trays arranged to swing from and toward each other according as the bucket is opened or closed, the combination, with each tray; relatively stationary framework, and two upright links arranged at opposite sides respectively of the said tray and pivotally attached at its lower end to the forward or inner portion of the tray and at its upper end to the framework, of two bell-crank levers fulcrumed to the said framework and arranged at opposite sides respectively of the said tray and operatively connected with the tray at the rear end of the tray; a vertically-movable suitably-guided member arranged centrally of the bucket; links operatively connecting the levers with the said vertically-movable member; a single cable for closing and hoisting and lowering the bucket, and means for detachably connecting the said cable with the aforesaid vertically-movable member, all arranged and operating substantially as shown, for the purpose specified.

12. In a bucket comprising two trays provided with cutting edges at the forward ends of their bottoms and arranged to swing from and toward each other according as the bucket is opened or closed, the combination, with each tray; relatively stationary framework, and means whereby the forward or inner portion of the said tray is suitably suspended from the said framework, of mechanism for swinging the two trays simultaneously from or toward each other; a cable for closing and hoisting and lowering the bucket, and means for detachably connecting the tray-swinging mechanism with the cable, and the arrangement of the parts being such that the cutting edges of the two trays only move inwardly and downwardly during the closing of the bucket, that the tray-swinging mechanism operates by gravity, upon detaching the said mechanism when the bucket is closed from the cable, to swing the trays apart and thereby open the bucket, and that the tray-swinging mechanism upon attaching the said mechanism to the cable when the bucket is open operates to swing the trays inwardly and thereby close the bucket by pulling upwardly upon the cable.

13. In a bucket comprising trays arranged to swing outwardly and upwardly or inwardly and downwardly according as the bucket is opened or closed, the combination, with the said trays; relatively stationary framework, and means whereby the forward portions of the trays are suitably suspended from the said framework, of a suitably-guided slide movable up and down the aforesaid framework and provided with a pin extending laterally through and beyond opposite sides respectively of the slide; tray-swinging mechanism operatively connected with the slide and arranged to actuate the trays outwardly or inwardly according as the slide moves downwardly or upwardly; a cable; a vertically-movable member arranged above the slide and attached to the cable; hooks pivotally supported from the said upper vertically-movable member and in their operative position overlapping the under sides of the aforesaid pin when the bucket is closed; means acting to retain the hooks in their operative position, and means for rendering the hooks inoperative.

14. In a bucket comprising trays arranged to swing outwardly and upwardly or inwardly and downwardly according as the bucket is opened or closed, the combination, with the said trays; relatively stationary framework, and means whereby the forward portions of the trays are suitably suspended from the said framework, of a suitably-guided slide movable up and down the aforesaid framework and provided with a laterally-projecting pin or member; tray-swinging mechanism operatively connected with the slide and arranged to actuate the trays outwardly or inwardly according as the slide moves downwardly or upwardly; a cable; a vertically-movable member arranged above the slide and attached to the cable; a hook pivotally supported from the said vertically-movable member and in its operative position overlapping the under side of the aforesaid pin or projecting member of the slide when the bucket is closed; means acting to retain the hook in its operative position, and means for rendering the hook inoperative.

15. In a bucket comprising trays arranged to swing outwardly and upwardly or inwardly and downwardly according as the bucket is opened or closed, the combination, with the said trays; relatively stationary framework, and means whereby the forward portions of the trays are suitably suspended from the said framework, of a suitably-guided slide movable up and down the aforesaid framework; tray-swinging mechanism operatively connected with the slide and arranged to actuate the trays outwardly or inwardly according as the slide moves downwardly or upwardly; a cable; a vertically-movable member arranged above the slide and attached to the cable, and means detachably connecting the said vertically-movable member to the slide when the bucket is

closed and adapted to be rendered inoperative.

16. In a bucket comprising trays arranged to swing outwardly and upwardly or inwardly and downwardly according as the bucket is opened or closed, the combination, with the said trays; relatively stationary framework provided with upright slideways, and means whereby the forward portions of the trays are suitably suspended from the said framework, of a slide engaging the aforesaid slideways and provided with a laterally-projecting pin or member; tray-swinging mechanism operatively connected with the slide and arranged to actuate the trays outwardly or inwardly according as the slide moves downwardly or upwardly; a cable; another slide arranged above the first-mentioned slide and provided with a hook pivotally supported therefrom and adapted to overlap the under side of the aforesaid pin or projecting member of the first-mentioned slide when the bucket is closed, said hook-bearing slide being attached to the cable and engaging the aforesaid slideways, and means acting to retain the hook in its operative position.

17. In a bucket comprising trays arranged to swing outwardly and upwardly or inwardly and downwardly according as the bucket is opened or closed, the combination, with the said trays; relatively stationary framework provided with upright slideways, and means whereby the forward portions of the trays are suitably suspended from the said framework, of a slide engaging the aforesaid slideways; tray-swinging mechanism operatively connected with the slide and arranged to actuate the trays outwardly or inwardly according as the slide moves downwardly or upwardly; a cable; another slide arranged above the first-mentioned slide and attached to the cable and engaging the aforesaid slideways; means for detachably connecting the lower slide to the upper slide, and means for limiting the upward movement of the upper slide.

18. In a bucket comprising trays arranged to swing outwardly and upwardly or inwardly and downwardly according as the bucket is opened or closed, the combination, with the said trays; relatively stationary framework provided with upright slideways, and means whereby the forward portions of the trays are suitably suspended from the said framework, of a slide engaging the aforesaid slideways and provided with a laterally-projecting pin or member; tray-swinging mechanism operatively connected with the slide and arranged to actuate the trays outwardly or inwardly according as the slide moves downwardly or upwardly; a cable; another slide arranged above the first-mentioned slide and provided with a hook pivotally supported therefrom and adapted to overlap the under side of the aforesaid pin or projecting member of the first-

mentioned slide when the bucket is closed, said hook-bearing slide being attached to the cable and engaging the aforesaid slideways; an endwise-shiftable bar arranged to render the hook inoperative; means for operating the said bar, and a spring acting to retain the hook in its operative position.

19. In a bucket comprising trays arranged to swing outwardly and upwardly or inwardly and downwardly according as the bucket is opened or closed, the combination, with the said trays; relatively stationary framework provided with upright slideways, and means whereby the forward portions of the trays are suitably suspended from the said framework, of a slide engaging the aforesaid slideways and provided with a laterally-projecting pin or member; tray-swinging mechanism operatively connected with the slide and arranged to actuate the tray outwardly or inwardly according as the slide moves downwardly or upwardly; a cable; another slide arranged above the first-mentioned slide and provided with a hook pivotally supported therefrom and adapted to overlap the under side of the aforesaid pin or projecting member of the said slide when the bucket is closed, said hook-bearing slide being attached to the cable and engaging the aforesaid slideways; an endwise-shiftable bar arranged within and longitudinally of the hook-bearing slide and in position to render the hook inoperative; a spiral spring mounted upon the said bar and acting to retain the hook in its operative position, and means for actuating the bar against the action of the spring.

20. In a bucket comprising trays arranged to swing outwardly and upwardly or inwardly and downwardly according as the bucket is opened or closed, the combination, with the said trays; relatively stationary framework, and means whereby the forward portions of the trays are suitably suspended from the said framework, of a suitably-guided slide movable up and down the aforesaid framework and provided with a laterally-projecting pin or member; a tray-swinging mechanism operatively connected with the slide and arranged to actuate the trays outwardly or inwardly according as the slide moves downwardly or upwardly; a cable; a vertically-movable member arranged above the aforesaid slide and provided with a hook pivotally supported therefrom and adapted to overlap the under side of the aforesaid pin or projecting member of the said slide when the bucket is closed, said hook-bearing member being attached to the cable; means for limiting the upward movement of the hook-bearing member; means whereby the hook is retainable in its operative position, and mechanism for actuating the hook from its operative into its inoperative position.

In testimony whereof I sign the foregoing specification, in the presence of two witnesses, this 20th day of September, 1904, at Cleveland, Ohio.

JOSEPH MAROUSCH.

Witnesses:

C. H. DORER,
G. M. HAYES.