



INTERNATIONAL APPLICATION PUBLISHED UNDER THE PATENT COOPERATION TREATY (PCT)

<p>(51) International Patent Classification ⁷ : F03D 1/06, 11/00, F16F 15/023</p>	<p>A1</p>	<p>(11) International Publication Number: WO 00/06898 (43) International Publication Date: 10 February 2000 (10.02.00)</p>
<p>(21) International Application Number: PCT/DK99/00423 (22) International Filing Date: 28 July 1999 (28.07.99) (30) Priority Data: BA 1998 00274 28 July 1998 (28.07.98) DK BA 1998 00275 28 July 1998 (28.07.98) DK BA 1998 00276 28 July 1998 (28.07.98) DK (71) Applicant (for all designated States except US): NEG MICON A/S [DK/DK]; Alsvej 21, DK-8900 Randers (DK). (72) Inventor; and (75) Inventor/Applicant (for US only): VELDKAMP, Herman, F. [NL/DK]; Hermodsvej 29, DK-8900 Randers (DK). (74) Agent: PLOUGMAN, VINGTOFT & PARTNERS A/S; Sankt Annæ Plads 11, P.O. Box 3007, DK-1021 Copenhagen k. (DK).</p>	<p>(81) Designated States: AE, AL, AM, AT, AT (Utility model), AU, AZ, BA, BB, BG, BR, BY, CA, CH, CN, CU, CZ, CZ (Utility model), DE, DE (Utility model), DK, DK (Utility model), EE, EE (Utility model), ES, FI, FI (Utility model), GB, GD, GE, GH, GM, HR, HU, ID, IL, IN, IS, JP, KE, KG, KP, KR, KZ, LC, LK, LR, LS, LT, LU, LV, MD, MG, MK, MN, MW, MX, NO, NZ, PL, PT, RO, RU, SD, SE, SG, SI, SK, SK (Utility model), SL, TJ, TM, TR, TT, UA, UG, US, UZ, VN, YU, ZA, ZW, ARIPO patent (GH, GM, KE, LS, MW, SD, SL, SZ, UG, ZW), Eurasian patent (AM, AZ, BY, KG, KZ, MD, RU, TJ, TM), European patent (AT, BE, CH, CY, DE, DK, ES, FI, FR, GB, GR, IE, IT, LU, MC, NL, PT, SE), OAPI patent (BF, BJ, CF, CG, CI, CM, GA, GN, GW, ML, MR, NE, SN, TD, TG).</p> <p>Published With international search report. Before the expiration of the time limit for amending the claims and to be republished in the event of the receipt of amendments.</p>	

(54) Title: WIND TURBINE BLADE WITH U-SHAPED OSCILLATION DAMPING MEANS

(57) Abstract

A wind turbine blade (1) is disclosed having oscillation damping means provided in the blade (1) for damping oscillations of the blade (1), in particular edgewise oscillations of the blade (1) in the rotational plane of a rotor on which the blade (1) is mounted. The damping means comprises a U-shaped cavity (2) in which a saturated solution of sodium chloride in water may oscillate in counter-phase with the oscillations of the blade (1). The upper end of the arms (5, 6) of the U-shaped cavity (2) are connected with a passage way (7) so that an O-shaped cavity (2) is provided. The cavity (2) may be tuned to dampen oscillations of the first natural edgewise frequency or the second natural edgewise frequency of the blade (1) or the damping means may comprise both types of dampers (2).

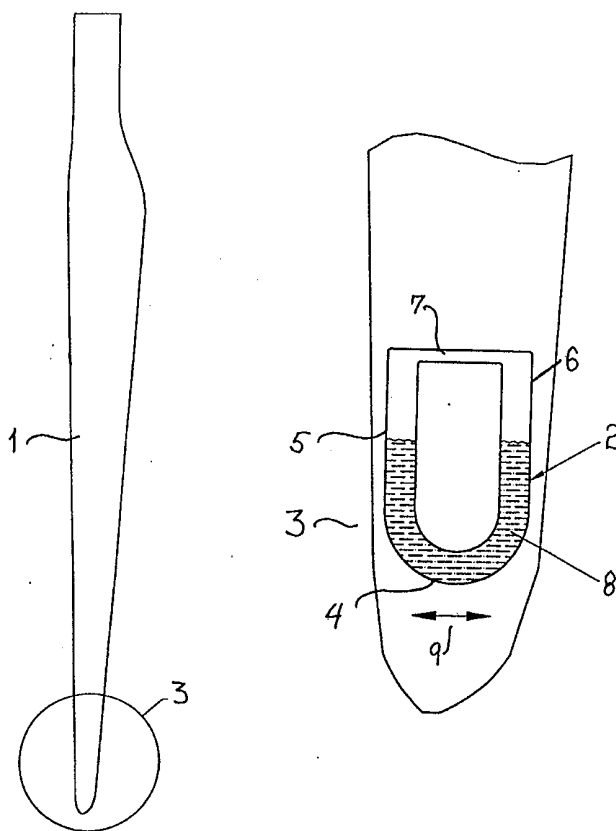

FOR THE PURPOSES OF INFORMATION ONLY

Codes used to identify States party to the PCT on the front pages of pamphlets publishing international applications under the PCT.

AL	Albania	ES	Spain	LS	Lesotho	SI	Slovenia
AM	Armenia	FI	Finland	LT	Lithuania	SK	Slovakia
AT	Austria	FR	France	LU	Luxembourg	SN	Senegal
AU	Australia	GA	Gabon	LV	Latvia	SZ	Swaziland
AZ	Azerbaijan	GB	United Kingdom	MC	Monaco	TD	Chad
BA	Bosnia and Herzegovina	GE	Georgia	MD	Republic of Moldova	TG	Togo
BB	Barbados	GH	Ghana	MG	Madagascar	TJ	Tajikistan
BE	Belgium	GN	Guinea	MK	The former Yugoslav Republic of Macedonia	TM	Turkmenistan
BF	Burkina Faso	GR	Greece			TR	Turkey
BG	Bulgaria	HU	Hungary	ML	Mali	TT	Trinidad and Tobago
BJ	Benin	IE	Ireland	MN	Mongolia	UA	Ukraine
BR	Brazil	IL	Israel	MR	Mauritania	UG	Uganda
BY	Belarus	IS	Iceland	MW	Malawi	US	United States of America
CA	Canada	IT	Italy	MX	Mexico	UZ	Uzbekistan
CF	Central African Republic	JP	Japan	NE	Niger	VN	Viet Nam
CG	Congo	KE	Kenya	NL	Netherlands	YU	Yugoslavia
CH	Switzerland	KG	Kyrgyzstan	NO	Norway	ZW	Zimbabwe
CI	Côte d'Ivoire	KP	Democratic People's Republic of Korea	NZ	New Zealand		
CM	Cameroon			PL	Poland		
CN	China	KR	Republic of Korea	PT	Portugal		
CU	Cuba	KZ	Kazakstan	RO	Romania		
CZ	Czech Republic	LC	Saint Lucia	RU	Russian Federation		
DE	Germany	LI	Liechtenstein	SD	Sudan		
DK	Denmark	LK	Sri Lanka	SE	Sweden		
EE	Estonia	LR	Liberia	SG	Singapore		

WIND TURBINE BLADE WITH U-SHAPED OSCILLATION DAMPING MEANS

The present invention relates to wind turbine blades with oscillation damping means provided in the blade for damping oscillations of the blade, in particular edgewise
5 oscillations of the blade in the rotational plane of a rotor on which the blade is mounted.

The invention relates in particular to damping means comprising a U-shaped cavity in which a liquid, preferably a saturated solution of sodium chloride in water, may oscillate in counter-phase with the oscillations of the blade. The upper end of the arms of the U-
10 shaped cavity are in an advantageous embodiment connected with a passage way so that an O-shaped cavity is provided. The cavity may be tuned to dampen oscillations of the first natural edgewise frequency or the second natural edgewise frequency of the blade or the damping means may comprise both types of dampers.

15 Furthermore, the invention relates to blades comprising dampers having a cylindrical element that may roll in a box in the blade and to dampers having a resiliently suspended pendulum.

BACKGROUND

20

Undesired oscillations may occur in wind turbines for power generation. These oscillations may include the entire turbine, i.e. several parts are oscillating in a combined mode, or the oscillations may occur locally in single part. Of particular severity are oscillations in the rotor blades either edgewise (in the rotor plane), flapwise (perpendicular to the rotor
25 plane), or in a combined edge- and flapwise mode. Whether these oscillations do occur is dependent on the wind turbine design and the meteorological conditions.

The oscillation phenomena may cause dangerously high loads on the blade and other parts of the wind turbine, which may lead to a sudden collapse or alternatively may be the
30 cause of fatigue damage and lifetime reduction, as cracks in the components slowly grow ultimately leading to failure. The occurrence of oscillations adds an uncertainty factor to predictions of lifetime loads on the various parts of a wind turbine, making it necessary to make the design stronger and heavier than would otherwise be the case.

CONFIRMATION COPY

The concept of damping of oscillations in blade arranged on a rotor has been known for many years from turbine blades as described in US 2,292,072, US 2,349,187 and US 2,999,669.

5 The general principle of dampen oscillations of wind turbine blades by building a damping device into the blades is described in WO-A-95/21327, and a number of examples of such devices are given, such as devices having a movable mass, a spring and a damper combined in different configurations, an electromagnetic device comprising a suspended aluminium disk in which eddy currents are induced during movement of the disk to provide
10 resistance to movement and a device comprising a container partly filled with a liquid and having a perforated damper plate, a Tuned Liquid Damper (TLD).

A damping device comprising a number of cavities, mainly spherical cavities, filled with granulate or a liquid, is disclosed in DK 95 00222 U3, and a damping device comprising a
15 number of containers partly filled with liquid, a Tuned Liquid Damper system (TLD), is disclosed in WO 99/32789.

A general problem is that it is difficult to produce an efficient damper of a feasible design that is sufficiently compact and flat in order to satisfy the severe spatial restrictions within
20 the blade.

A wind turbine blade having a mechanical resonator comprising two coupled pendulums is disclosed in EP 0 853 197 A1. A compact design of the damper may be provided but the coupling mechanisms are mechanically rather complex.

25

DESCRIPTION OF THE INVENTION

Damping of oscillations in wind turbine blades, in particular edgewise oscillations, is important for preventing fatigue damages and failure of the blades, and the issue is
30 becoming increasingly important with the development of larger wind turbines and a more light construction of the blades.

It is an object of the present invention to provide a wind turbine blade having an efficient damper of a feasible design that is sufficiently compact and flat in order to satisfy the
35 severe spatial restrictions within the blade.

It is a further object of the present invention to provide a blade having a damper that is of a simple construction in order to reduce the costs of the damper and at the same time provide a damper that requires no or very little maintenance during its expected lifetime.

5 As the design of the construction of wind turbine blades becomes more light and the blades are made longer, an increasing demand arises for damping of oscillations of the second natural frequency of the blade, in particular oscillations of the second natural frequency of the blade in the rotational plane of the rotor, i.e. second order edgewise oscillations. It is a still further object of the present invention to provide a blade having a
10 damper for damping oscillations of the second natural frequency of the blade, in particular edgewise oscillations.

It is a yet still further object of the present invention to provide a blade having means for damping oscillations of the second natural frequency as well as means for damping
15 oscillations of the first natural frequency.

Thus, the present invention relates to a wind turbine blade for being arranged on a rotor of a wind turbine, the blade comprising oscillation damping means defining a U-shaped cavity within the blade, the cavity being partly filled with a liquid, of which cavity the
20 bottom of the U-shape is arranged towards a tip end of the blade and the arms of the U-shape are oriented substantially toward a hub end of the blade.

The cavity may typically be defined by means of a tube or a shell, but the cavity may also be an integrated part of the construction elements of the blade. The hub end of the blade
25 is understood to be the end connected to the hub of the rotor and the tip end is understood to be the free end of the blade. The U-shape should be understood in a broad sense as a cavity having a middle or bottom part and two arms, that preferably are arranged symmetrically with respect to the bottom part so that oscillations are dampened symmetrically. The bottom part may be quite short as compared to the liquid filled part of
30 the arms so that the shape is more like a V which may be advantageous because the natural frequency of a damper of such design varies less at high amplitudes of the liquid column inside the cavity than for a damper having a longer bottom part. However, a feasible design has shown to be more U-shaped than V-shaped and a design in which the length of the liquid column contained within the bottom part is approximately equal to

twice the length of the liquid column of each of the arms provides satisfactory damping properties of the damper as well as relatively small amplitudes of the liquid column.

The arms of the cavity are in a particular embodiment arranged in a rotational plane of the rotor and the oscillation damping means is tuned to dampen oscillations of the first natural frequency of the blade in the rotational plane so that edgewise oscillations of the blade are dampened. These oscillations are mainly within the range of 1-5 Hz to which frequency range the oscillation damping means preferably is tuned.

10 In order to provide a proper damping of the blade, the oscillation damping means should be designed to dampen the oscillations of the first natural frequency of the blade in the rotational plane with a magnitude equivalent to a logarithmic decrement of the amplitude of at least 2%.

15 The logarithmic decrement δ of the amplitude is defined as

$$\delta = \frac{1}{n} \ln \left(\frac{a_1}{a_n} \right)$$

where n is the number of oscillations

a_1 is the amplitude of the first oscillation, and

a_n is the amplitude of the n th oscillation.

20

The structure of the blade has in itself a damping effect in the oscillations, and the oscillations of the first natural frequency of the blade in the rotational plane should totally dampen with the combined effect of the structure and the damper with a magnitude equivalent to a logarithmic decrement of the amplitude of at least 5% and preferably within the range of 6-15% in order to prevent excessive load on the blade from edgewise oscillations.

The mass of the liquid being movable in the direction of the oscillations is in advantageous embodiments of the present invention equivalent to 0,5% to 2% of the equivalent oscillating mass of the blade in the first natural oscillating mode at the radial position of the damping means. The equivalent oscillating mass is commonly found as a mass positioned at the tip of a blade of no mass and this mass is converted to an equivalent oscillating mass of another radial position by multiplying the mass with the ratio between the amplitudes of an oscillation at the tip and at the radial position.

The upper end of the arms of the U-shaped cavity should be designed so that it is avoided that a portion of air is captured between the surface of the liquid and the inner wall of the arm in a manner so the portion of air acts as a spring, since the presence of such springs
5 has proven to be disadvantageous. The damper may be designed with long arms or the arms may be connected to a reservoir or to the atmosphere. However, long arm or a reservoir is space consuming and is therefore not ideal for a damper to be build into a blade and an opening to the atmosphere causes vapour of the liquid to leave the cavity, thus reducing the amount of liquid and changing the natural frequency of the damper over
10 time unless means for adjusting the amount of liquid in the damper is provided for. The most advantageous design is when a passage way is defined at the upper end of the U-shaped cavity, the passage way connecting the two arms so that an O-shaped cavity is provided.

15 The passage way is preferably designed so that the air may pass back and forth with only a low resistance, since the damper counteracts the oscillations of the blade by being in counter-phase with these oscillations and not by dampening its own oscillations. For this reason it is preferred that the average cross-sectional area of the passage way is equal to at least half of the average cross-sectional area of the U-shaped cavity and more
20 preferred that the average cross-sectional area of the passage way is substantially the same as the average cross-sectional area of the U-shaped cavity. An embodiment of the damper of the present invention in which the cross-sectional area is of a substantially constant magnitude throughout the O-shape has proven to posses excellent properties for the purpose.

25

In order to make the wind turbine fit to meet environmental changes and be operational under most circumstances, the freezing temperature of the liquid should be below -10 degrees Celsius, preferably below -18 degrees Celsius.

30 The density of the liquid is advantageously at least 1.1 metric ton per cubic meter, preferably at least 1.15 metric ton per cubic meter so that the physical size of the oscillation damping means may be reduced as compared to the use of pure water as a liquid.

An inexpensive liquid that is preferred for the oscillating mass is water, preferably comprising at least one agent for lowering the freezing temperature of the water and/or at least one agent for increasing the density of the liquid. Mercury or other liquid metal can also be used with the advantage that the high density allows for a very compact design of the damper, but water is still advantageous because it does not present an environmental hazard if it leaks from the containers.

A number of different agents may be employed, among these a number of salts. A preferred agent is sodium chloride because it is environmentally harmless and because the solubility of sodium chloride in water hardly changes with the temperature so that crystallisation will not occur in the container. Sodium chloride both lowers the freezing temperature of the water and increases the density.

The water may comprise at least 18 mass percentage of sodium chloride, preferably at least 22 mass percentage of sodium chloride and most preferred about 26 mass percentage of sodium chloride which is a saturated solution.

Another suitable agent for both purposes is glycerol.

Likewise and according to the present invention, the arms of the cavity may be arranged in a rotational plane of the rotor and the oscillation damping means be tuned to dampen oscillations of the second natural frequency of the blade in the rotational plane. Such damping means are preferably tuned to dampen oscillations of a frequency being within the range of 5-12 Hz, and the oscillation damping means are preferably, likewise for oscillations of the first natural frequency, designed to dampen the oscillations of the second natural frequency of the blade in the rotational plane with a magnitude equivalent to a logarithmic decrement of the amplitude of at least 2%.

The total damping of oscillations of the second natural frequency of the blade in the rotational plane is preferably of a magnitude equivalent to a logarithmic decrement of the amplitude of at least 5%, most preferred within the range of 6-15%. The mass of the liquid being movable in the direction of the oscillations is preferably equivalent to 0,5% to 2% of the equivalent oscillating mass of the blade in the second natural oscillating mode at the radial position of the damping means.

It is understood that a blade having means for damping oscillations of the first natural frequency as well as means for damping oscillations of the second natural frequency also is according to the present invention.

- 5 It is advantageous for all the above mentioned blades that the oscillation damping means are arranged in a portion of the blade having large amplitudes of the oscillating movement which for means for damping oscillations of the first natural frequency as well as for means for damping oscillations of the second natural frequency is a position in a tip end part of the blade. The oscillations of the second natural frequency will have a nodal point
10 near the tip end part of the blade and a region between the hub end and the nodal point at which the amplitudes of oscillations of the second natural frequency are large and a damper may be positioned.

Another embodiment according to the invention of a blade with a damper is a wind turbine
15 blade for being arranged on a rotor of a wind turbine, the blade comprising oscillation damping means having a box and a cylindrical element that engages with one side wall of the box, said side wall being arranged towards a tip end of the blade and curving towards a hub end of the blade so that the cylindrical element may roll from one side to another side of said side wall about a neutral position.

20

Such a damper may be given a narrow design so that it fits into a blade. The cylindrical element will at the occurrence of oscillations start to roll back and forth in counter-phase with the oscillations of the blade and thus dampen the oscillations.

- 25 The damper is preferably oriented so that the cylindrical element may roll in a rotational plane of the rotor and the oscillation damping means is tuned to dampen oscillations of the first natural frequency of the blade in the rotational plane.

The box may be at least partly filled with a liquid so as to dampen the movements of the
30 cylindrical element and to tune the natural frequency of the damper. The liquid may be water with an agent as described previously but a lubricating oil may also be advantageous in order to diminish the wear on the engaging parts of the cylindrical element and the box.

The cylindrical element and the side wall may in a particularly preferred embodiment comprise mutually engaging elements so as to ensure that the periphery of the cylindrical element does not slip on the side wall when the element rolls. Thereby, the movement of the cylindrical element as it rolls and thus the natural frequency of the damper and the damping effect is fully predictable and will not change due to slip. The engaging elements may e.g. be a toothed wheel and a toothed rim or a sprocket wheel and a chain.

A further embodiment according to the invention of a blade having a damper is a wind turbine blade for being arranged on a rotor of a wind turbine, the blade comprising oscillation damping means having a pendulum with a mass element which may swing about a pivot axis, the pendulum being connected to the blade at the pivot axis with a resilient material so that energy is absorbed in the material when the pendulum swings.

Such a damper may be given a narrow design so that it fits into a blade and the pendulum will start to oscillate in counter-phase with the blade if oscillations of the blade occurs. The oscillations of the blade are dampened by the counter-phase oscillations of the pendulum and the movement of the pendulum is dampened by the resilient material by absorption of kinetic energy in the resilient material.

The damper is preferably oriented so that the pendulum may swing in a rotational plane of the rotor and the oscillation damping means is tuned to dampen oscillations of the first natural frequency of the blade in the rotational plane.

According to one embodiment, the mass element of the pendulum is arranged closer to a tip end of the blade than the pivot axis.

According to another embodiment of the invention, the mass element is arranged closer to a hub end of the blade than the pivot axis.

The resilient material comprises rubber in a preferred embodiment of the invention.

The mass element of the pendulum is preferably equipped with a wheel member for engaging with side wall parts of a cavity defined within the blade so as to support the mass element in the direction of the pivot axis, the wheel member being arranged about an axis being perpendicular to the pivot axis.

BRIEF DESCRIPTION OF THE DRAWINGS

The description is accompanied by drawings in which embodiments of the present
5 invention is described.

Fig. 1 is a graphical representation of the logarithmic decrement due to the presence of
liquid in the U-shaped damper as a function of the volume of the liquid,

10 Fig. 2 shows a wind turbine blade having a U-shaped damper,

Fig. 3 shows a preferred embodiment of a U-shaped damper,

Fig. 4 shows the damper of Fig. 3 arranged in the tip of a blade,
15

Fig. 5 shows a damper having a cylindrical element,

Fig. 6 shows a damper having a pendulum of which the mass element is closer to the tip
end of the blade, and
20

Fig. 7 shows a damper having a pendulum of which the mass element is closer to the hub
end of the blade.

DETAILED DESCRIPTION OF THE INVENTION

25

The U-shaped damper primarily dampens the oscillations by being in counter-phase with
the blade, so that the motion of the liquid inside the damper is in the opposite direction of
the oscillating movement of the blade as seen in a system rotating with the angular speed
of the rotor. The first natural frequency f , being also the damping frequency, of a U-
30 shaped damper is theoretically found as

$$f = \frac{1}{2\pi} \sqrt{\frac{2\Omega^2 R \sin \varphi}{L}}$$

where f is the damping frequency of the U-shaped damper [Hz],

Ω is the rotational speed of the rotor [rad/s],

R is the distance from the centre of the rotor to the free surface of the liquid in the damper when in neutral position [m],

φ is the angle between the direction of the legs of the U-shaped damper and the instantaneous direction of movement of the blade, and

L is the length of the liquid column inside the damper along the centre of gravity of cross-sections of the column [m].

The damper is subjected to an average apparent gravity of $\Omega^2 R$ due to the rotation of the blade. The apparent gravity will due to the upright position of the rotor vary with $\pm 9.8 \text{ m/s}^2$ during one rotation of the rotor.

An example of a blade is a 32 metre long blade with a damper placed at $R = 29.5 \text{ m}$, a rotational speed of $\Omega = 1.807 \text{ rad/s}$ and a first natural frequency in the rotational plane of the blade, an edgewise natural frequency, f_b , of 2.19 Hz and the legs of the damper are parallel to the longitudinal axis of the blade so that $\varphi = \pi/2$. Thus, the length L of the liquid column found from the above equation is 1.017 m.

By varying the apparent gravity with $\pm 9.8 \text{ m/s}^2$ it is found for the present blade that the natural frequency of the damper varies $\pm 0.13 \text{ Hz}$ during a rotation which is equal to $\pm 6\%$ of the average natural frequency.

The cross-sectional inner area of the damper employed (as shown in Figs. 3 and 4) is $A = 0.0112 \text{ m}^2$ everywhere, the distance d between the centres of gravity of the two legs is 0.317 m and the density of the liquid, being water with 26 mass percentage of sodium chloride, is $\rho = 1200 \text{ kg/m}^3$. The mass of the liquid being movable in the direction of the oscillations is $M = A \cdot d \cdot \rho = 4.2 \text{ kg}$. The equivalent mass M_E of the blade for the first natural oscillating mode is found to be 514.9 kg at the tip. The deflection due to oscillations of the first natural mode at R is 0.864 times the deflection at the tip so the equivalent mass at R is $M_E/0.864$ and M is thus equivalent to 0.7% of the equivalent oscillating mass of the blade in the first natural mode at the radial position of the damper.

An experiment has been conducted with the damper employed with the blade in which the damper is mounted on a pendulum. The mass ratio of the blade was reproduced in the

experiment and the logarithmic decrement of the amplitude of the pendulum and the damper without liquid as well as with different volumes of liquid was measured. The logarithmic decrement due to the presence of liquid in the damper is shown as a function of the volume of the liquid in Fig. 1.

5

The structural damping of the blade in the edgewise direction is 3.8% for which reason a satisfactory damping of the damper is taken to be 2.5% in order to reach a total damping of oscillations in the rotational plane of the rotor of at least 6.3%. The damping is found to be satisfactory when the volume is within a range corresponding to a frequency range of
10 $\pm 4.6\%$ around an optimal volume of liquid providing an optimal damping of 10.5%. The optimal volume of liquid turned out to be larger than the theoretically predicted volume of liquid found from the above equation for the first natural frequency f of the damper.

This highly important result for design of this type of dampers shows that the optimal
15 volume of liquid and thus the optimal length L of the liquid column inside the damper along the centre of gravity for the present damper is 1.117 times the volume, respectively the length L , found from the theoretical equation. Although this may vary with different design of a damper, a general conclusion is that an increase of the length of the liquid column in the range of 8-16%, probably of about 12% as compared to the theoretical
20 value must be expected in order to reach the correct, optimal damping frequency of the damper.

A wind turbine blade having a U-shaped damper 2 is shown in Fig. 2. The damper 2 is arranged in a tip end 3 of the blade 1 shown enlarged at the right part of Fig. 2. The
25 damper 2 comprises a bottom part 4 of the U-shape, two arms 5, 6 arranged in the rotational plane of the rotor and a passage way 7 connecting the two arms 5, 6 at an upper end. An amount of liquid 8 is provided in the damper 2 and the amount of liquid being movable in the direction of the oscillations is indicated with an arrow 9.

30 Fig. 3 shows a preferred embodiment of a U-shaped damper 2 with dimensions given in millimetres. The damper is designed for the 32 meter long blade 1 given as an example previously. The inner cross-sectional area of the damper 2 is substantially constant in all of the damper 2, including the passage way 7. The distance d between the centres of gravity of the two legs 5, 6 is 317 millimetres and is also shown in the figure.

35

Fig. 4 shows the damper 2 of Fig. 3 arranged in the tip end 3 of a 32 meter long blade 1, the length of the blade 1 from the hub end is given in meters at the left part of the figure. The dimensions of the blade 1 are given in millimetres and the construction of the blade 1 with three layers is indicated as LAY 1, LAY 2 and LAY 3.

5

Another embodiment of the invention is shown in Fig. 5. A tip end 3 of a blade 1 is shown with a damper 2 having a cylindrical element 10 comprised within a box 11 that is filled with a liquid 12. The box 11 is arranged so that the curved side wall 13 on which the cylindrical element 10 rolls is positioned towards the tip end 3 of the blade 1 and so that
10 the cylindrical element 10 may roll in the rotational plane of the rotor to which the blade 1 is connected so as to dampen oscillations in the rotational plane. The movement of the cylindrical element 10 is indicated with an arrow 14. The cylindrical element 10 comprises a toothed wheel 15 which engages with a toothed rim 16 of the curved side wall 13. The radius R of the curved side wall 13 must be less than the distance from the hub to the
15 curved side wall 13 in order to achieve the correct damping effect of the damper 2.

Two embodiments of dampers 2 comprising a pendulum 17 are shown in Figs. 6 and 7 of which Fig. 6 shows a damper 2 having a pendulum 17 of which the mass element 18 is closer to the tip end 3 of the blade 1 than the pivot 19, and Fig. 7 shows a damper 2
20 having a pendulum 17 of which the mass element 18 is closer to the hub end of the blade 1 than the pivot 19. The pendulum 17 is suspended in a resilient material and may swing in the rotational plane of the rotor so as to dampen edgewise oscillations of the blade 1. The movement of the pendulum is indicated with arrows 20, 21.

CLAIMS

1. A wind turbine blade for being arranged on a rotor of a wind turbine, the blade comprising oscillation damping means defining a U-shaped cavity within the blade, the
5 cavity being partly filled with a liquid, of which cavity the bottom of the U-shape is arranged towards a tip end of the blade and the arms of the U-shape are oriented substantially toward a hub end of the blade.
2. A wind turbine blade according to claim 1, wherein the arms of the cavity are arranged
10 in a rotational plane of the rotor and the oscillation damping means is tuned to dampen oscillations of the first natural frequency of the blade in the rotational plane.
3. A wind turbine blade according to claim 2, wherein the oscillation damping means are
15 tuned to dampen oscillations of a frequency being within the range of 1-5 Hz.
4. A wind turbine blade according to claim 2 or 3, wherein the oscillation damping means dampens the oscillations of the first natural frequency of the blade in the rotational plane with a magnitude equivalent to a logarithmic decrement of the amplitude of at least 2%.
- 20 5. A wind turbine blade according to claim 4, wherein oscillations of the first natural frequency of the blade in the rotational plane dampen with a magnitude equivalent to a logarithmic decrement of the amplitude of at least 5%.
6. A wind turbine blade according to claim 5, wherein oscillations of the first natural
25 frequency of the blade in the rotational plane dampen with a magnitude equivalent to a logarithmic decrement of the amplitude within the range of 6-15%.
7. A wind turbine blade according to any of the preceding claims, wherein the mass of the liquid being movable in the direction of the oscillations is equivalent to 0,5% to 2% of the
30 equivalent oscillating mass of the blade in the first natural oscillating mode at the radial position of the damping means.
8. A wind turbine blade according to any of the preceding claims, wherein a passage way is defined at the upper end of the U-shaped cavity, the passage way connecting the two
35 arms so that an O-shaped cavity is provided.

9. A wind turbine blade according to claim 8, wherein the average cross-sectional area of the passage way is equal to at least half of the average cross-sectional area of the U-shaped cavity.

5

10. A wind turbine blade according to claim 9, wherein the average cross-sectional area of the passage way is substantially the same as the average cross-sectional area of the U-shaped cavity.

10 11. A wind turbine blade according to any of the preceding claims, wherein the freezing temperature of the liquid is below -10 degrees Celsius, preferably below -18 degrees Celsius.

12. A wind turbine blade according to claim 11, wherein the liquid is water comprising at least one agent for lowering the freezing temperature of the water.

13. A wind turbine blade according to any of the preceding claims, wherein the density of the liquid is at least 1.1 metric ton per cubic meter, preferably at least 1.15 metric ton per cubic meter.

20

14. A wind turbine blade according to claim 13, wherein the liquid is water comprising at least one agent for increasing the density of the liquid.

15. A wind turbine blade according to any of claims 12-14, wherein at least one agent is sodium chloride.

16. A wind turbine blade according to claim 15, wherein the liquid is water comprising at least 18 mass percentage of sodium chloride, preferably at least 22 mass percentage of sodium chloride and most preferred about 26 mass percentage of sodium chloride.

30

17. A wind turbine blade according to any of claims 12-14, wherein at least one agent is glycerol.

18. A wind turbine blade according to any of the preceding claims, wherein the oscillation damping means are arranged in a tip end part of the blade.

35

19. A wind turbine blade according to any of the preceding claims, wherein the arms of the cavity are arranged in a rotational plane of the rotor and the oscillation damping means is tuned to dampen oscillations of the second natural frequency of the blade in the rotational plane.

5

20. A wind turbine blade according to claim 19, wherein the oscillation damping means are tuned to dampen oscillations of a frequency being within the range of 5-12 Hz.

21. A wind turbine blade according to claim 19 or 20, wherein the oscillation damping
10 means dampens the oscillations of the second natural frequency of the blade in the rotational plane with a magnitude equivalent to a logarithmic decrement of the amplitude of at least 2%.

22. A wind turbine blade according to claim 21, wherein oscillations of the second natural
15 frequency of the blade in the rotational plane dampen with a magnitude equivalent to a logarithmic decrement of the amplitude of at least 5%.

23. A wind turbine blade according to claim 22, wherein oscillations of the second natural
20 frequency of the blade in the rotational plane dampen with a magnitude equivalent to a logarithmic decrement of the amplitude within the range of 6-15%.

24. A wind turbine blade according to any of claims 19-23, wherein the mass of the liquid
being movable in the direction of the oscillations is equivalent to 0,5% to 2% of the
equivalent oscillating mass of the blade in the second natural oscillating mode at the
25 radial position of the damping means.

25. A wind turbine blade for being arranged on a rotor of a wind turbine, the blade
comprising oscillation damping means having a box and a cylindrical element that
engages with one side wall of the box, said side wall being arranged towards a tip end of
30 the blade and curving towards a hub end of the blade so that the cylindrical element may roll from one side to another side of said side wall about a neutral position.

26. A wind turbine blade according to claim 25, wherein the cylindrical element may roll in
a rotational plane of the rotor and the oscillation damping means is tuned to dampen
35 oscillations of the first natural frequency of the blade in the rotational plane.

27. A wind turbine blade according to claim 25 or 26, wherein the box is at least partly filled with a liquid.

28. A wind turbine blade according to any of claims 25-27, wherein the cylindrical element and the side wall comprise mutually engaging elements so as to ensure that the periphery of the cylindrical element does not slip on the side wall when the element rolls.

29. A wind turbine blade for being arranged on a rotor of a wind turbine, the blade comprising oscillation damping means having a pendulum with a mass element which may swing about a pivot axis, the pendulum being connected to the blade at the pivot axis with a resilient material so that energy is absorbed in the material when the pendulum swings.

30. A wind turbine blade according to claim 29, wherein the pendulum may swing in a rotational plane of the rotor and the oscillation damping means is tuned to dampen oscillations of the first natural frequency of the blade in the rotational plane.

31. A wind turbine blade according to claim 28 or 29, wherein the mass element is arranged closer to a tip end of the blade than the pivot axis.

20

32. A wind turbine blade according to claim 28 or 29, wherein the mass element is arranged closer to a hub end of the blade than the pivot axis.

33. A wind turbine blade according to any of claims 28-32, wherein the resilient material comprises rubber.

34. A wind turbine blade according to any of claims 28-33, wherein the mass element comprises a wheel member for engaging with side wall parts of a cavity defined within the blade so as to support the mass element in the direction of the pivot axis, the wheel member being arranged about an axis being perpendicular to the pivot axis.

30

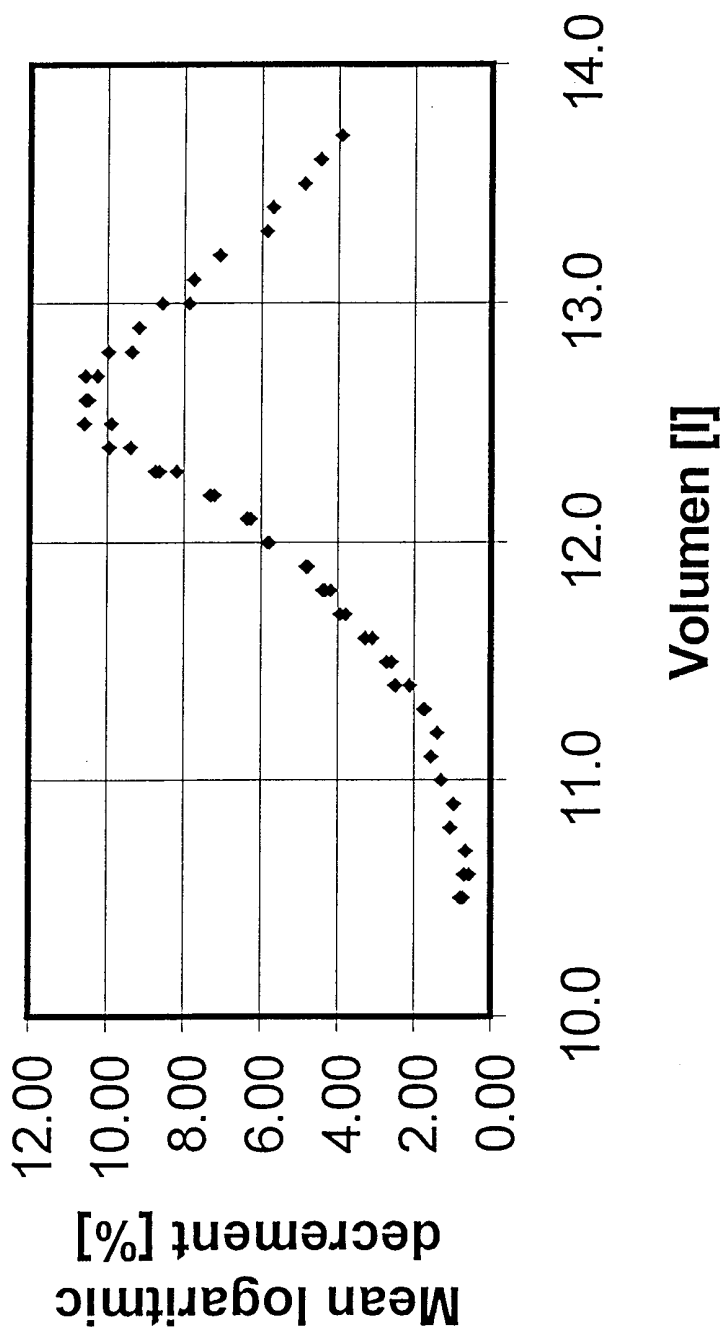

Fig. 1

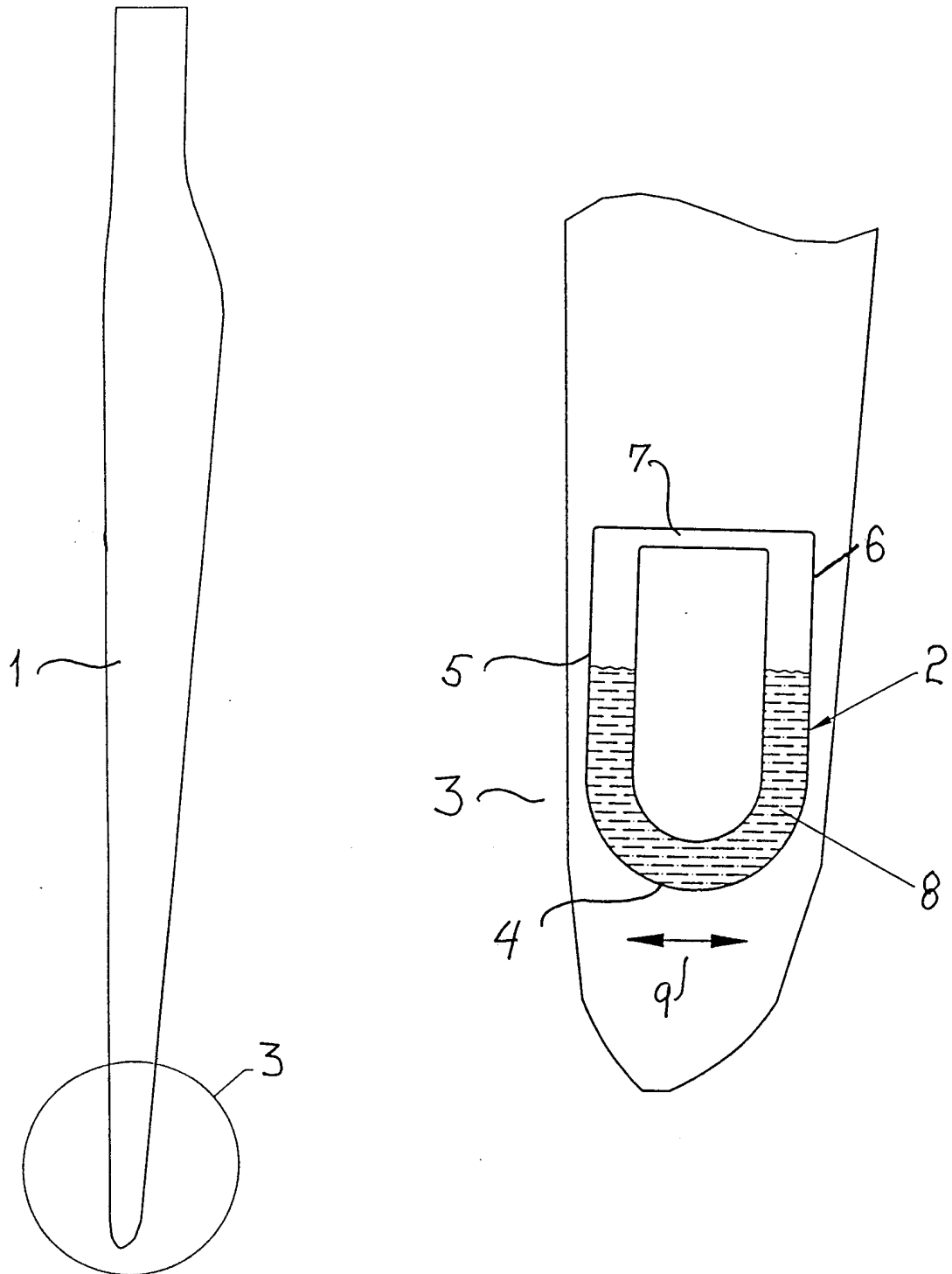

Fig. 2

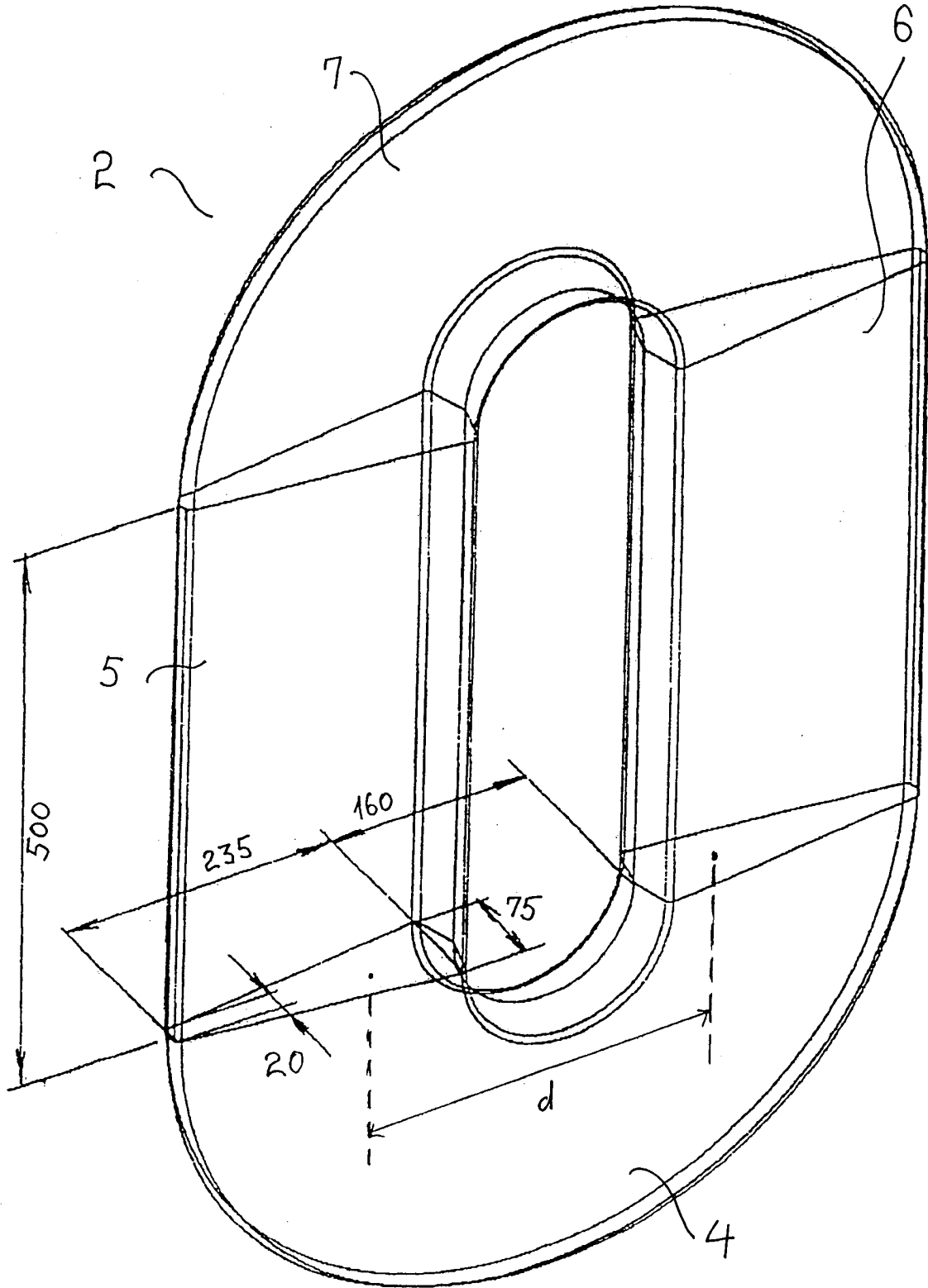

Fig. 3

4/5

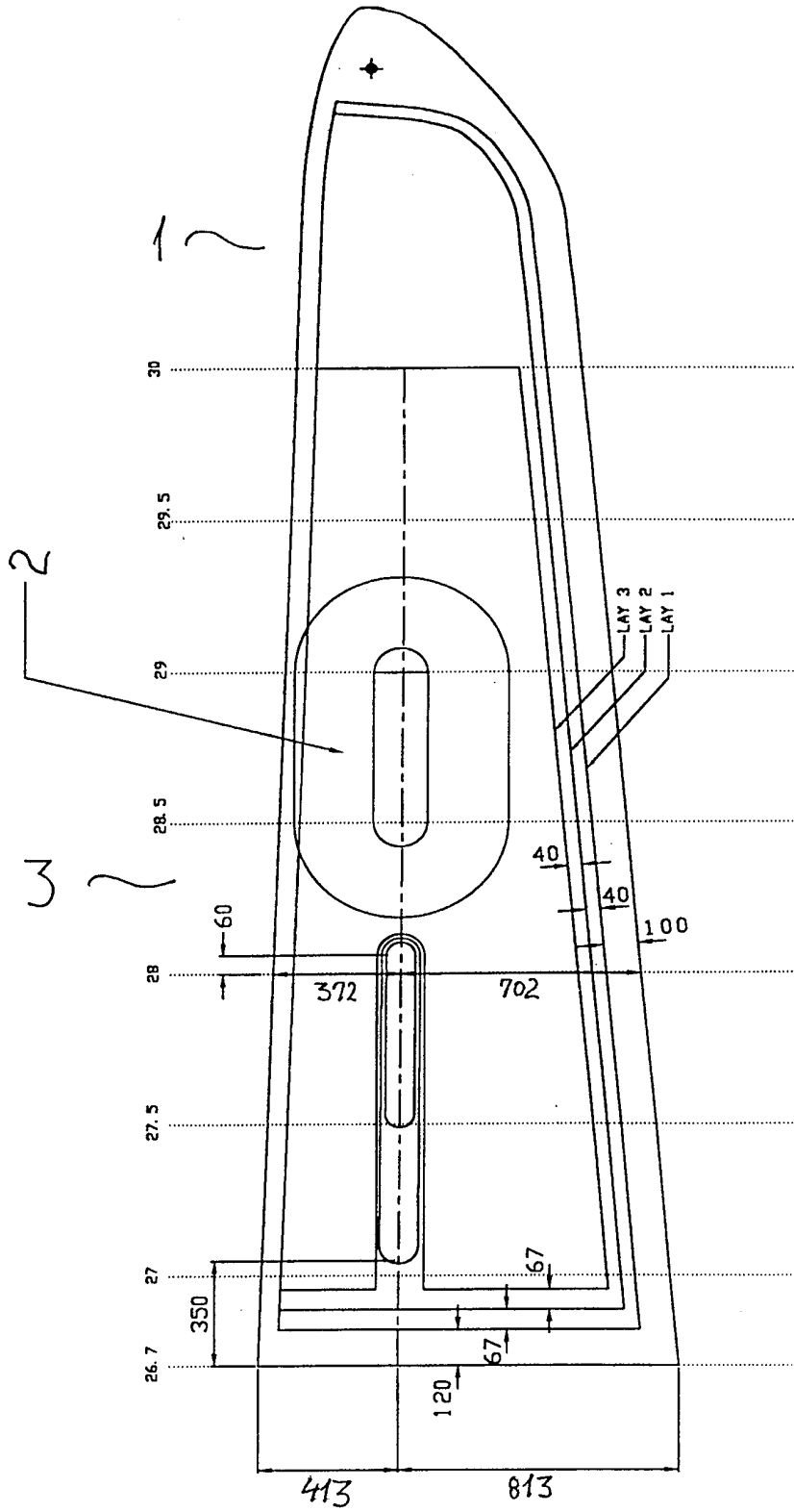

Fig. 4

5/5

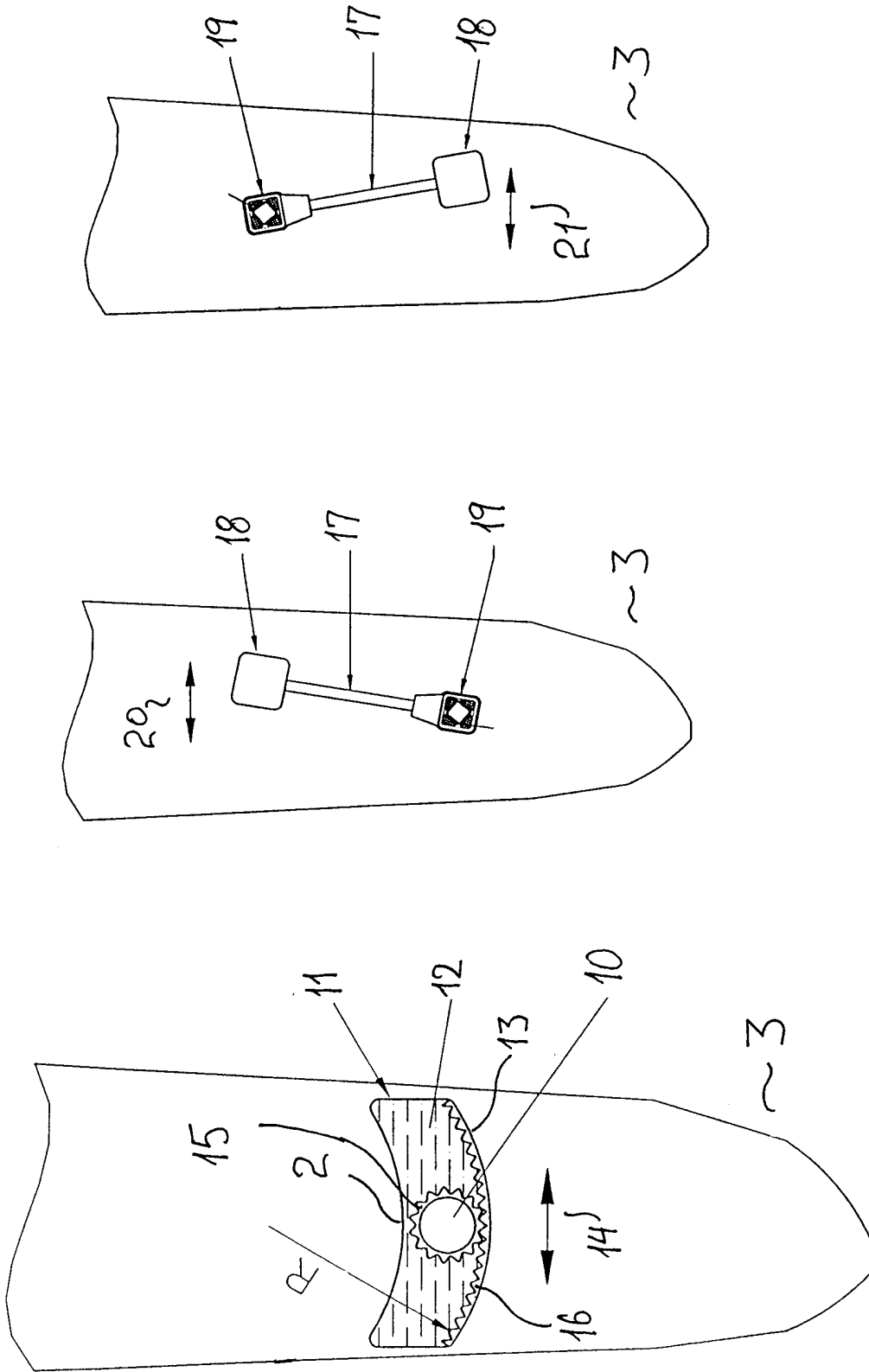

Fig. 5

Fig. 6

Fig. 7

INTERNATIONAL SEARCH REPORT

Internat Application No

PCT/DK 99/00423

A. CLASSIFICATION OF SUBJECT MATTER

IPC 7 F03D1/06 F03D11/00 F16F15/023

According to International Patent Classification (IPC) or to both national classification and IPC

B. FIELDS SEARCHED

Minimum documentation searched (classification system followed by classification symbols)

IPC 7 F03D F16F F01D

Documentation searched other than minimum documentation to the extent that such documents are included in the fields searched

Electronic data base consulted during the international search (name of data base and, where practical, search terms used)

C. DOCUMENTS CONSIDERED TO BE RELEVANT

Category °	Citation of document, with indication, where appropriate, of the relevant passages	Relevant to claim No.
Y	WO 95 21327 A (LM GLASFIBER AS ;BONUS ENERGY AS (DK); STIESDAL HENRIK (DK)) 10 August 1995 (1995-08-10) cited in the application abstract page 1, line 15-19 page 3, line 12 -page 4, line 13 page 4, line 27 -page 5, line 7 page 5, line 16 - line 19 page 9, line 7-21 figures 1,3 <p style="text-align: center;">--- -/--</p>	1-7, 9-14, 18-24

Further documents are listed in the continuation of box C. Patent family members are listed in annex.

° Special categories of cited documents :

<p>*A* document defining the general state of the art which is not considered to be of particular relevance</p> <p>*E* earlier document but published on or after the international filing date</p> <p>*L* document which may throw doubts on priority claim(s) or which is cited to establish the publication date of another citation or other special reason (as specified)</p> <p>*O* document referring to an oral disclosure, use, exhibition or other means</p> <p>*P* document published prior to the international filing date but later than the priority date claimed</p>	<p>*T* later document published after the international filing date or priority date and not in conflict with the application but cited to understand the principle or theory underlying the invention</p> <p>*X* document of particular relevance; the claimed invention cannot be considered novel or cannot be considered to involve an inventive step when the document is taken alone</p> <p>*Y* document of particular relevance; the claimed invention cannot be considered to involve an inventive step when the document is combined with one or more other such documents, such combination being obvious to a person skilled in the art.</p> <p>*&* document member of the same patent family</p>
--	--

Date of the actual completion of the international search	Date of mailing of the international search report
2 November 1999	14.01.00

Name and mailing address of the ISA European Patent Office, P.B. 5818 Patentlaan 2 NL - 2280 HV Rijswijk Tel. (+31-70) 340-2040, Tx. 31 651 epo nl, Fax: (+31-70) 340-3016	Authorized officer <p style="text-align: center;">CRIADO Y JIMENEZ, F.</p>
--	---

INTERNATIONAL SEARCH REPORT

Intern: al Application No

PCT/DK 99/00423

C.(Continuation) DOCUMENTS CONSIDERED TO BE RELEVANT

Category °	Citation of document, with indication, where appropriate, of the relevant passages	Relevant to claim No.
Y	GB 2 090 339 A (ROLLS ROYCE) 7 July 1982 (1982-07-07) abstract page 1, line 46 - line 480 page 1, line 83 - line 96 page 1, line 103 -page 2, line 9 page 2, line 117 - line 121 page 3, line 1 - line 8 figures	1-7, 9-14, 18-24
P,A	--- WO 99 32789 A (GRABAU PETER ;LM GLASFIBER AS (DK)) 1 July 1999 (1999-07-01) cited in the application abstract	1-24
A	--- US 1 442 217 A (CHANTIERS DE L'ATLANTIQUE) 16 January 1923 (1923-01-16) claim 1; figures	1-24
T	--- K.KAGAWA ET AL: "Semi active and passive vibration control of structure by fluid system" ASME PRESSURE VESSELS AND PIPING DIV.PROC. 1194 CONFERENCE, vol. 289, 6 - 9 November 1999, pages 41-48, XP002121178 Chicago,Il,Usa abstract, page 41. page 46: "Application to ships",fig 19. page 48, "Conclusions".	1-24
A	--- H. GAO ET AL: "Optimization of tuned liquid column dampers." ENGINEERING STRUCTURES, vol. 19, no. 6, June 1997 (1997-06), pages 476-486, XP002121179 Oxford, England abstract -----	1-24

INTERNATIONAL SEARCH REPORT

International application No.
PCT/DK 99/00423

Box I Observations where certain claims were found unsearchable (Continuation of item 1 of first sheet)

This International Search Report has not been established in respect of certain claims under Article 17(2)(a) for the following reasons:

1. Claims Nos.:
because they relate to subject matter not required to be searched by this Authority, namely:

2. Claims Nos.:
because they relate to parts of the International Application that do not comply with the prescribed requirements to such an extent that no meaningful International Search can be carried out, specifically:

3. Claims Nos.:
because they are dependent claims and are not drafted in accordance with the second and third sentences of Rule 6.4(a).

Box II Observations where unity of invention is lacking (Continuation of item 2 of first sheet)

This International Searching Authority found multiple inventions in this international application, as follows:

1. As all required additional search fees were timely paid by the applicant, this International Search Report covers all searchable claims.
2. As all searchable claims could be searched without effort justifying an additional fee, this Authority did not invite payment of any additional fee.
3. As only some of the required additional search fees were timely paid by the applicant, this International Search Report covers only those claims for which fees were paid, specifically claims Nos.:
4. No required additional search fees were timely paid by the applicant. Consequently, this International Search Report is restricted to the invention first mentioned in the claims; it is covered by claims Nos.:

1-24

Remark on Protest

- The additional search fees were accompanied by the applicant's protest.
- No protest accompanied the payment of additional search fees.

FURTHER INFORMATION CONTINUED FROM PCT/ISA/ 210

This International Searching Authority found multiple (groups of) inventions in this international application, as follows:

1. Claims: 1-24

A wind turbine blade oscillation damping means built near the tip of the blade of the tuned liquid oscillator type.

2. Claims: 25-28

A wind turbine blade oscillation damping means built in near the tip of the blade where the damping means is of the rolling cylinder in liquid cavity type.

3. Claims: 29-34

Wind turbine oscillation damping means built in near the tip of the blade where the damping means is of the resiliently coupled pendulum.

INTERNATIONAL SEARCH REPORT

Information on patent family members

International Application No

PCT/DK 99/00423

Patent document cited in search report	A	Publication date	Patent family member(s)	Publication date
WO 9521327	A	10-08-1995	DK 15894 A AU 1805795 A EP 0792414 A	08-08-1995 21-08-1995 03-09-1997
GB 2090339	A	07-07-1982	US 4460314 A	17-07-1984
WO 9932789	A	01-07-1999	AU 1484099 A	12-07-1999
US 1442217	A	16-01-1923	NONE	