

(19) **DANMARK**

(10) **DK/EP 3429232 T3**



Patent- og
Varemærkestyrelsen

(12) **Oversættelse af
europæisk patentskrift**

-
- (51) Int.Cl.: **H 04 R 25/00 (2006.01)**
- (45) Oversættelsen bekendtgjort den: **2023-03-06**
- (80) Dato for Den Europæiske Patentmyndigheds bekendtgørelse om meddelelse af patentet: **2023-01-11**
- (86) Europæisk ansøgning nr.: **18187832.3**
- (86) Europæisk indleveringsdag: **2007-06-12**
- (87) Den europæiske ansøgnings publiceringsdag: **2019-01-16**
- (62) Stamansøgningsnr: **07110079.6**
- (84) Designerede stater: **AT BE BG CH CY CZ DE DK EE ES FI FR GB GR HU IE IS IT LI LT LU LV MC MT NL PL PT RO SE SI SK TR**
- (73) Patenthaver: **Oticon A/S, Kongebakken 9, 2765 Smørum, Danmark**
- (72) Opfinder: **Boldt, Jesper Bünsow, Kærlodden 34, 2760 Måløv, Danmark**
Elmedyb, Thomas Bo, Mosedraget 19A, 2730 Herlev, Danmark
- (74) Fuldmægtig i Danmark: **Oticon A/S, Kongebakken 9, 2765 Smørum, Danmark**
- (54) Benævnelse: **ONLINE ANTI-TILBAGEKOBLINGSSYSTEM TIL ET HØREAPPARAT**
- (56) Fremdragne publikationer:
EP-A- 1 191 814
WO-A-2006/063624
WO-A-2007/113282
WO-A1-2007/053896
US-A1- 2004 136 557

DESCRIPTION

TECHNICAL FIELD

[0001] The invention relates to feedback compensation in a hearing aid system comprising a feedback path with an adaptive filter for estimating acoustical feedback from an output transducer to an input transducer of the hearing aid system. The invention furthermore relates to a method of adapting a hearing aid system to varying acoustical input signals, and to a method of manufacturing a hearing aid system.

[0002] The invention may e.g. be useful in digital hearing aids for use in a variety of acoustical environments.

BACKGROUND ART

[0003] It is a well known problem that a hearing aid can become unstable and howl when loop gain exceeds 1. The (open) loop gain is a product of the gain in the hearing aid and the coupling between the receiver (speaker) and microphone, primarily, but not exclusively, through a vent in the earpiece. The vent is generally inserted in the earpiece of hearing aids so as to avoid occlusion. The coupling between the receiver and microphone is called the external or physical or acoustical feedback path and may have other origins than a deliberately arranged vent, e.g. mechanical coupling between various parts of the earpiece, etc.

[0004] Two methods can be used to help in situations where loop gain gets too high: Either by subtracting an estimate of the external feedback from the input signal (the microphone signal) or by reducing the gain in the hearing aid. The first method is used in so-called Dynamic Feedback Cancellation (DFC) or Anti-Feedback (AFB) systems, these terms are used interchangeably in the present application. This method has the advantage that the loop gain can exceed 1 without howls, meaning that the hearing impaired can get more gain or a larger vent compared to a situation *without* a DFC/AFB-system. A schematic illustration of a hearing aid system comprising a forward path, an acoustic feedback path and an electric feedback cancellation path is shown in FIG. 1b. The second method is sometimes used in the fitting situation, where the external feedback is measured and the maximum allowable gain is adjusted ('the feedback manager', FBM). But this is typically a one-time (offline) measurement, possibly performed by a technician, such as an audiologist, typically using specially adapted equipment.

[0005] US patent no. 5,619,580 describes a hearing aid with digital, electronic compensation for acoustic feedback comprising a digital compensation circuit, including an adjustable digital filter and a first part, which monitors the loop gain and regulates the hearing aid amplification, so that the loop gain is less than a constant K , and a second part, which carries out a statistical

evaluation of the filter coefficients, and changes the feedback function in accordance with this evaluation.

[0006] US patent no. 6,219,427 deals with a digital hearing aid comprising a feedback cancellation system in the form of a cascade of two adaptive filters, a first filter for modelling near constant factors in the physical feedback path, and a second, quickly varying, filter for modelling variable factors in the feedback path, the first filter varying substantially slower than the second filter.

[0007] Published PCT-application WO 2006/063624 describes a hearing aid comprising a processor for amplifying an electrical input signal, an adaptive feedback suppression filter and a feedback model gain estimator that determines an upper processor gain limit based on inputs from the microphone, the adaptive filter, and the output from the processor.

[0008] EP1191814A1 and US20040136557A1 deal with a hearing aid with an adaptive filter for suppression of acoustic feedback and a controller that is adapted to compensate for acoustic feedback by determination of a first parameter of an acoustic feedback loop of the hearing aid and adjustment of a second parameter of the hearing aid in response to the first parameter whereby generation of undesired sounds is substantially avoided. WO2007113282A1 describes a hearing aid comprising at least one microphone for converting input sound into an input signal, a subtraction node for subtracting a feedback cancellation signal from the input signal thereby generating a processor input signal, a hearing aid processor for producing a processor output signal by applying an amplification gain to the processor input signal, a receiver for converting the processor output signal into output sound, an adaptive feedback cancellation filter for adaptively deriving the feedback cancellation signal from the processor output signal by applying filter coefficients, calculation means for calculating the auto-correlation of a reference signal, and an adaptation means for adjusting the filter coefficients with an adaptation rate, wherein the adaptation rate is controlled in dependency of the auto-correlation of the reference signal.

DISCLOSURE OF INVENTION

[0009] An object of the present invention is to provide an alternative acoustic feedback compensation scheme.

[0010] The general idea disclosed herewith relates to an online anti-feedback system, which continuously avoids or suppresses howls, by estimating the feedback path and adjusting the maximum allowable gain in the hearing aid. The online anti-feedback system of the present invention uses the feedback path estimate to adjust maximum gain in the forward path. Thereby the resulting loop gain can be controlled. In an embodiment, the adjustment of the maximum allowable gain in the forward path is based *solely* on the feedback estimate (and predefined maximum loop gain values, *without* considering *current* loop gain or).

[0011] The frequency dependent loop gain LG in the loop comprising the forward path and the electrical feedback path is the sum of the (insertion) gain IG in the forward path, also termed 'forward gain' (e.g. fully or partially implemented by a signal processor (SP)) and the gain FBG in the electrical feedback path aimed at minimizing, preferably cancelling, the acoustical feedback between the receiver and the microphone of the hearing aid system (i.e. in a logarithmic representation, $LG(f)=IG(f)+FBG(f)$, where f is the frequency). In practice, the frequency range $\Delta f = [f_{\min}; f_{\max}]$ considered by the hearing aid system, e.g. $20 \text{ Hz} \leq f \leq 20 \text{ kHz}$, is divided into a number N of frequency bands (FB), e.g. $N=16$, $(FB_1, FB_2, \dots, FB_N)$ and the expression for the loop gain can be expressed in dependence of the frequency bands, i.e. $LG(FB_i)=IG(FB_i)+FBG(FB_i)$, $i = 1, 2, \dots, N$, or simply $LG_i=IG_i+FBG_i$.

[0012] Objects of the invention are achieved by the invention described in the accompanying claims.

A hearing aid system:

[0013] An object of the invention is achieved by a hearing aid system as defined in claim 1. The hearing aid system comprises an input transducer, a forward path, an output transducer and an electrical feedback path, the forward path comprising a signal processing unit for modifying an electrical input signal to a specific hearing profile over a predefined frequency range, wherein the predefined frequency range comprises a number of frequency bands, for which at least maximum forward gain values IG_{\max} for each band can be stored in a memory, the electrical feedback path comprising an adaptive filter for estimating acoustical feedback from the output to the input transducer. Advantageously, the hearing aid system further comprises an online feedback manager unit for - with a predefined update frequency - identifying current feedback gain in each frequency band of the feedback path, and for subsequently adapting the maximum forward gain values in each of the frequency bands in dependence thereof in accordance with a predefined scheme as defined in claim 1.

[0014] This has the advantage of providing a diminished probability for disturbing feedback improved feedback cancellation.

[0015] The value of current feedback gain determined by the online feedback manager for a particular frequency band may vary across the frequency band. In principle any of the values for a given frequency band determined at a given point in time may be used (e.g. the value corresponding to the middle frequency of the band, or to the minimum or maximum frequency of the band or e.g. the minimum value of the band). Preferably, however, the 'current feedback gain' value used for a particular frequency band i is the *maximum* value of current feedback gain in the band at the actual point in time (t_n) , $FBG_{\max,i}(t_n)$. The maximum value in a set of feedback gain values for a particular frequency band may be determined e.g. by a standard software routine.

[0016] In the present application, a differentiation between 'online' and 'offline' adjustment of a hearing aid is made. 'Offline' adjustment is taken to refer to adjustments made (infrequently, e.g. less than once a week or month) using external or additional instruments, e.g. at special occasions such as an initial or later fitting of the hearing aid, e.g. performed by another person (e.g. an audiologist) than the wearer of the hearing aid. 'Online' adjustment is taken to refer to adjustments that can be made by the hearing aid itself, e.g. automatically or initiated by a wearer, e.g. in-situ, without any external instruments.

[0017] The term 'update frequency' in relation to the online feedback manager is taken to mean the frequency of *checking* the above criterion of 'identifying current feedback gain in each frequency band of the feedback path, and for subsequently adapting the maximum forward gain values in each of the frequency bands in dependence thereof in accordance with a predefined scheme'. The *storage* of possible maximum forward gain values may be performed at the same or at a lower frequency than the update frequency, possibly depending on whether or not a change to a value of one or more of the frequency bands has occurred since the last check. In an embodiment, storage is performed every time at least one maximum forward gain value of a frequency band has been changed.

[0018] The parts of a hearing aid system according to the present invention are body worn and can be located in a *common* housing and e.g. worn behind the ear (BTE), or alternatively be located in *different* housings, one e.g. located in the ear canal another behind the ear or worn elsewhere on the body of the wearer. The communication between the two or more housings can be acoustical and or electrical and/or optical. The electrical and optical communication can be wired or wireless. In an embodiment, the input transducer and the processing unit (including the OFBM) are enclosed in the same physical unit and located e.g. behind an ear or in an ear canal.

[0019] Embodiments of an online feedback manager according to the invention can work in at least three different configurations. With or without an AFB system, and in a relatively fast or slow mode:

1. *Without AFB system - relatively fast online feedback manager.*

[0020] The online feedback manager (OFBM) continuously calculates the loop gain and adjusts the forward gain in the hearing aid so as to prevent the loop gain to exceed a certain (predefined) loop gain limit. In this configuration the loop gain limit must be below zero (e.g. -5 dB). The OFBM must be fast enough to react to quickly changing feedback paths e.g. caused by using a headset, putting on a hat, or passing a wall. In an embodiment, the update frequency of the OFBM is larger than or equal to once every second (1 Hz), such as larger than or equal to 5 Hz, such as larger than or equal to 10 Hz.

2. *With AFB system - relatively fast online feedback manager.*

[0022] In this configuration the OFBM is working as a safety measure in cooperation with an AFB system. Present day AFB systems make it possible to increase the loop gain without introducing howls and artefacts, and it is possible to increase the loop gain above 0 dB. However, the AFB will always be restricted, which means that the loop gain can not increase infinitely - the AFB system has a maximum loop gain under which it can operate (e.g. $<+5$ dB loop gain). If the loop gain exceeds this maximum, the OFBM will decrease the gain in the hearing aid so as to prevent conditions where the AFB system can not work acceptable. The OFBM must be fast enough to react to quickly changing feedback paths e.g. caused by using a headset, putting on a hat, giving a hug, or passing a wall. In an embodiment, the update frequency of the OFBM is larger than or equal to once every hour, such as once every second (1 Hz), such as larger than or equal to 5 Hz, such as larger than or equal to 10 Hz.

[0023] 3. *With AFB system - relatively slow online feedback manager.*

[0024] This system can best be compared to an off-line feedback manager used in the fitting situation (i.e. occasionally). The slow OFBM will slowly update the estimate made with the off-line feedback manager. Compared to previous systems (1 and 2) which are "reactive" this system (3) is "preventive": Reactive in the sense that the fast OFBM is active, when the loop gain gets too high. Preventive in the sense that the slow OFBM tries to avoid that the loop gain gets too high. Target situations for this mode of operation are to deal with a) broken or badly fitted ear-moulds, b) wrong settings of the hearing aid (e.g. too much gain), c) ear-moulds for children (which typically become too small during child growth) d) or other slow changes in the feedback. In an embodiment, the update frequency of the OFBM is larger than or equal to once every 100 hours, such as larger than or equal to once every 10 hours, such as larger than or equal to once every 2 hours, such as larger than or equal to once every hour. In an embodiment, the slow OFBM is adapted to accommodate changes in feedback that may occur during the day, e.g. due to minor changes in the 'local environment' of an earpiece due to a wearer's physical activity (e.g. resulting sweat being produced in the ear canal), the ear canal exhibiting slight changes in dimensions, etc.. Such variations may be taken account for by OFBM updates being performed in the range every 5-60 minute, e.g. every 20th or every 30th minute.

[0025] In an embodiment (e.g. of a slow OFBM), the maximum gain values of the forward path $IG_{\max,i}$ for a particular frequency band i are continuously updated (with the predefined update frequency) *independently* of current loop gain LG_i in the band.

[0026] In an embodiment, a relatively fast as well as a relatively slow OFBM is implemented in the *same* hearing aid system.

[0027] In an embodiment, each of the relatively fast and relatively slow OFBM may be activated or deactivated by a software setting. In an embodiment, each may be activated or deactivated individually on a per frequency band level. In an embodiment, the relatively slow OFBM is dependent on the relatively fast OFBM. In an embodiment, the relatively slow OFBM

uses inputs from the relatively fast OFBM.

[0028] The target for the OFBM is either to reduce the risk of howling by decreasing the max gain, or to increase the max gain in situations where the risk of howling is reduced.

[0029] In an embodiment, the system builds on an existing anti-feedback mechanism (max gain in forward path) but will make it adaptive/variable.

[0030] In an embodiment, the OFBM makes it possible to increase or decrease the forward gain depending on the current situation.

[0031] In an embodiment, the OFBM has only a direct effect on the current gain, when the requested gain is above the maximum gain.

[0032] The OFBM system can either be preventive or reactive. A preventive OFBM will continuously try to optimize the performance and reduce the risk of the DFC system being pushed too hard. A reactive OFBM will try to help in situations where the DFC system has been pushed too hard and artefacts and bad sound quality are present.

[0033] In a particular embodiment, the predefined scheme comprises that the maximum forward gain value for a frequency band is adapted so that the sum of the current feedback gain and the forward gain values in that particular frequency band is *smaller than* a predefined maximum loop gain value for *that band*.

[0034] In a particular embodiment, the maximum forward gain value is adapted so that the sum of the current feedback gain and the maximum forward gain values is *equal* to a predefined maximum loop gain value for *that band*. Thereby the maximum forward gain value for a particular frequency band can be increased or decreased depending on the actual values of current feedback gain and the maximum loop gain values currently stored for *that band*.

[0035] In a particular embodiment, the predefined maximum loop gain value is substantially identical for all frequency bands. Alternatively, the predefined maximum loop gain value can be different from band to band or from a range of bands to another range of bands (e.g. from relatively low frequency bands to relatively high frequency bands).

[0036] In a particular embodiment, different sets of predefined maximum loop gain values are stored corresponding to different modes of the OFBM, e.g. to a mode where the OFBM operates without an AFB-system in a relatively fast mode, to a mode where the OFBM cooperates with an AFB system in a relatively fast mode, and to a mode where the OFBM cooperates with an AFB system in a relatively slow mode.

[0037] In a particular embodiment, the predefined scheme comprises that the maximum forward gain values for *all* frequency bands are adapted every time the OFBM is updated. Alternatively, the update frequency can be different for different frequency bands, e.g. relatively

higher at frequency bands comprising relatively higher frequencies and relatively lower at frequency bands comprising relatively lower frequencies. Further, in an embodiment, the OFBM can be selectably switched on or off for a particular frequency band.

[0038] In a particular embodiment, a predefined maximum loop gain value $LG_{\max,i}$ (which may be different from frequency band to frequency band) is +12 dB, such as +10 dB, such as +5 dB, such as +2 dB, such as 0 dB, or such as -2 dB. The (predefined) maximum loop gain $LG_{\max,i}$ in a particular frequency band i is e.g. determined from an estimate of the maximum allowable loop gain before howling occurs ($LG_{\text{howl},i}$) diminished by a predefined safety margin ($LG_{\text{margin},i}$). In an embodiment, the predefined maximum loop gain values are determined on an empirical basis, e.g. from a trial and error procedure.

[0039] In a particular embodiment, the predefined frequency range is from 20 Hz to 20 kHz, such as from 20 Hz to 12 kHz, such as from 20 Hz to 8 kHz.

[0040] In a particular embodiment, the predefined frequency range comprises at least 2 frequency bands, such as at least 4, such as at least 8, such as at least 12, such as at least 16, such as at least 32 bands. The more frequency bands, the more detailed an adaptation to a user's hearing profile can be made. In an embodiment, the frequency bands form sequentially neighbouring ranges, together constituting the predefined frequency range considered by the signal processing unit (such as e.g. indicated by FB_1 - FB_8 of FIG. 7 together constituting the full frequency range $[f_{\min}; f_{\max}]$ considered by the signal processor).

[0041] In an embodiment, the compression is the same in all frequency bands. The term compression is in the present context taken to refer to the phenomenon that the processing of an input signal is performed in such a way that a certain input level range is mapped to a *smaller* output level range (i.e. the input signal is attenuated at a particular frequency, if the input level at that frequency is above a predefined level). However, alternatively, the compression can be different in different frequency bands. This has the advantage that a more flexible adaptation to the frequency dependent hearing profile and level sensitivity of a particular user can be provided.

[0042] The update frequency is adapted to the relevant hearing situation, e.g. based on one or more particular sensors for classifying the present environment (e.g. directional microphones or external signals forwarding such information to the hearing aid) and/or based on recorded data of the frequency of howl appearing in a predefined time period, e.g. the last minute or the last 10 minutes or the last hour.

[0043] In a particular embodiment, the order of the update frequency is in the once a second range, or in the once a minute range, or in the once an hour range or in the once every 10 hours range or in the once every 100 hours range.

[0044] In a particular embodiment, the hearing aid system is adapted to provide an update

frequency larger than or equal to 0.001 Hz, such as larger than or equal to 0.01 Hz, such as larger than or equal to 0.1 Hz, such as larger than or equal to 1 Hz, such as larger than or equal to 10 Hz, such as larger than or equal to 100 Hz, such as larger than or equal to 1 kHz. In a particular embodiment, the update frequency is in the range between 0.001 Hz and 1 kHz, such as in the range between 0.005 Hz and 0.05 Hz or between 0.5 Hz and 5 Hz or between 50 Hz and 500 Hz.

[0045] An OFBM according to the invention can be fully or partially implemented in a digital signal processor of the hearing aid system and can be fully or partially implemented in software.

[0046] An algorithm for an embodiment of an OFBM can be described as follows (it is anticipated that predefined values of loop gain $LG_{max,i}$ and insertion gain $IG_{max,i}$ are stored in a memory of the hearing aid system):

1. 1. Estimate feedback path H' .
2. 2. Find maximum feedback gain in each frequency band.
3. 3. Adapt the maximum forward gain in dependence of the maximum feedback gain in that frequency band.

[0047] In this algorithm, the maximum forward gain is modified *without* calculating *current* loop gain. $IG_{max,i}(t_n)$ is calculated as $LG_{max,i}(\text{predefined}) - FBG_{max,i}(t_n)$. The hearing aid system is adapted to run the algorithm at different points in time $t_1, t_2, \dots, t_n, \dots$

[0048] Another algorithm for an embodiment of an OFBM can be described as follows (again, it is anticipated that predefined values of $LG_{max,i}$ and $IG_{max,i}$ are stored in a memory of the hearing aid system):

1. 1. Estimate feedback path H' .
2. 2. Find maximum feedback gain in each frequency band (compression channels).
3. 3. Calculate the loop gain in each of the frequency bands.
4. 4. If the loop gain is above a certain limit, decrease the gain in that frequency band.

[0049] The hearing aid system is adapted to run the algorithm at different points in time $t_1, t_2, \dots, t_n, \dots$

[0050] A more detailed algorithm for an embodiment of an OFBM for a time increment between t_{n-1} and t_n can be described as follows (again, it is anticipated that predefined (pd) values of $LG_{max,i}$, $LG_{max,i}(pd)$, and $IG_{max,i}$, $IG_{max,i}(pd)$, are stored in a memory of the hearing aid system):

1. 1. Estimate the gain versus frequency $FBG(f)$ of the feedback path H' at a given time t_n . This can e.g. be done using an adaptive filter, such as an LMS filter.
2. 2. Find the estimated maximum feedback gain $FBG_{max,i}$ in each frequency band FB_i (compression channels) at t_n . This can e.g. be done by computing the frequency response of the estimated feedback path and finding the maximum feedback gain in each frequency band.
3. 3. Calculate the loop gain LG_i at t_n in each of the frequency bands FB_i based on the estimated maximum feedback gain values $FBG_{max,i}$ at t_n and the stored maximum forward gain values $IG_{max,i}$ for each frequency band. The stored $IG_{max,i}$ values are typically those stored in a previous cycle, e.g. at $t=t_{n-1}$ (or earlier or such values stored from the manufacturer or in a fitting situation).
4. 4. For each frequency band: If the loop gain $LG_i(t_n)$ is larger than or equal to a predefined maximum loop gain value $LG_{max,i}(pd)$, adapt the forward gain $IG_{max,i}(t_n)$ in *that* frequency band (i) according to a predefined scheme.
5. 5. In case $IG_{max,i}(t_n)$ is different from $IG_{max,i}(t_{n-1})$, store the new maximum forward gain values $IG_{max,i}(t_n)$ for each frequency band. These are valid at least until the next estimate of the feedback path is performed at time $t_{n+1} > t_n$.

$t_n - t_{n-1}$ (and $t_{n+1} - t_n$) represents a time interval between two updates of the OFBM.

[0051] In case the system is automatically updated at regular intervals, $1/(t_{n+1} - t_n)$ ($=1/(t_n - t_{n-1})$) represents an update frequency of the OFBM.

[0052] In an embodiment (e.g. alternatively to step 5 above), a just determined value of a parameter, here $IG_{max,i}$, at $t=t_n$ is not immediately used, but termed the 'target value'. Predefined fade-rates FR_i [db/time step] for each frequency band are used. In an embodiment, the present value of $IG_{max,i}$, $IG_{max,i}(t_{n-1}) + \text{SUM}[FR_i(t_n - t_{n-1})]$, is adapted to 'fade' (converge) towards the just determined value $IG_{max,i}(t_n)$ at a (fade) rate of FR_i . In an embodiment, FR_i is different for positive and negative changes to $IG_{max,i}$. In an embodiment, the fade rate FR_{i-} is larger for a negative change ($IG_{max,i}(t_n) < IG_{max,i}(t_{n-1})$) than the fade rate FR_{i+} for a positive change in $IG_{max,i}$. to provide a relatively fast adjustment in case of a too high gain is detected.

[0053] In an embodiment, in step 4 the forward gain IG_i is adapted to provide that the current loop gain LG_i is smaller than the predefined maximum loop gain value $LG_{max,i}$ for a frequency band i.

[0054] In an embodiment, in step 4 the forward gain IG_i is adapted to provide that the current loop gain LG_i is substantially equal to the predefined maximum loop gain value $LG_{max,i}$ for a frequency band i.

[0055] In an embodiment, $LG_{max,i} \leq 12$ dB, such as $LG_{max,i} \leq 10$ dB, such as $LG_{max,i} \leq 5$ dB,

such as ≤ 4 dB, such as ≤ 3 dB, such as ≤ 2 dB, such as ≤ 1 dB, such as ≤ 0 dB, such as ≤ -1 dB.

[0056] In an embodiment, the algorithm is run at regular intervals in time, with a predefined update frequency f_{upd} . In an embodiment, $f_{\text{upd}} = 1/(t_{n+1}-t_n)$.

[0057] In an embodiment, a set of update values (of current feedback gain and/or maximum forward gain) from a number of update times t_1, t_2, \dots, t_q (possibly corresponding to a certain update frequency or to a number of non-periodic, e.g. user initiated, update times) are stored in a memory and an average value is calculated for the time period t_1-t_q and this value is used for the next period of time (e.g. of length t_q-t_1), after which the values stored in the next period are averaged and so on.

[0058] In particular embodiments, the update frequency of the OFBM is adapted to the relevant situations where it can improve the performance, for example Hug (~1 s.), chewing / yawning (~10 s.), Telephone (~1-10 min.), Putting on a hat (~1 hour), change of the mould/ear channel through the day (~10 hours), change of the mould/ear channel through days (~100 hours). In a particular embodiment, the update or update frequency of the OFBM can be activated by a user. In a particular embodiment, the update or update frequency of the OFBM is *only* activated by a user. In a particular embodiment, the update or update frequency of the OFBM is activated by events in the acoustical environment of the hearing aid system, e.g. changing background noise or a change from sound without voice signals to sound including voice-signals (or vice versa). In an embodiment, the update or update frequency of the OFBM is activated by an external signal. In an embodiment, the external signal is forwarded to the hearing aid by a transmitter located in a particular acoustical environment, e.g. in a particular room of a building, in a transport facility, etc.

[0059] In a particular embodiment, the effect of the OFBM is limited, e.g. to +/- 5 dB of the initial max gain. In a particular embodiment, the OFBM is constrained to a predefined maximum change, e.g. only to be allowed to make maximum of +/- 2 dBs of change. This has the advantage of reducing the risk of making too large and sudden changes (e.g. increases in gain). In a particular embodiment, the OFBM is constrained to only be able to decrease the max gain.

[0060] In a particular embodiment, the effect of the OFBM is adapted to be frequency dependent in that the adjustment of maximum (and/or minimum) gain in at least one frequency band is different from other frequency bands.

[0061] In a particular embodiment, the OFBM is adjustable in the fitting situations in that e.g. a choice between higher gain/higher risk of howls or lower gain/lower risk of howls can be made. By increasing the ('predefined') maximum allowable loop gain, the signal is better in certain situations, but the risk of experiencing howl in certain situations is increased, and vice versa.

[0062] In a particular embodiment, the OFBM is adapted to use information from other sub systems (e.g. environmental detectors or external signals indicating the kind or acoustical environment currently present) in the HA to increase the performance by making the decisions more confident (e.g. by influencing the update frequency).

A method of adapting a hearing aid system:

[0063] In a further aspect, there is provided a method of adapting a hearing aid system to varying acoustical input signals as defined in claim 11. The hearing aid system comprises an input transducer transforming an acoustical input signal to an electrical input signal, a forward path, an output transducer for transforming an electrical output signal to an acoustical output signal and a feedback path, the forward path comprising a signal processing unit for modifying an electrical input signal to a specific hearing profile over a predefined frequency range, wherein the predefined frequency range comprises a number of frequency bands that can be individually adapted, the feedback path comprising an adaptive filter for estimating acoustical feedback from the output to the input transducer. Advantageously, the method comprising

- a) identifying maximum feedback gain in each frequency band,
- b) calculating the loop gain in each of the frequency bands based on previously stored values of maximum forward gain and said maximum feedback gain,
- c) checking whether the loop gain is above a certain maximum loop gain value in each frequency band,
 - d1) if yes, decreasing the maximum forward gain in that frequency band,
 - d2) if no, depending on a predefined first OFBM-parameter, *increasing* the maximum forward gain OR continue without changing the maximum forward gain in that frequency band,
- e) storing in a memory the new values of the maximum forward gain in each frequency band,
- f) repeating the algorithm a) - e) with a predefined update frequency as described in claim 11.

[0064] In a particular embodiment, in step d) the maximum forward gain is *decreased* or *increased* with a predefined amount, e.g. 0.5 dB, 1 dB or 2 dB.

[0065] In a particular embodiment, in step d) the maximum forward gain is *decreased* or *increased* at most to a predetermined fraction of (such as down or up *to*) said predetermined maximum loop gain value in each frequency band.

[0066] In a particular embodiment, the predetermined maximum loop gain values are identical in all frequency bands. They might alternatively be different for some or all bands.

[0067] The features of the hearing aid system described above, in the detailed description and in the claims are - where appropriate - intended for being combined with the present method of adapting a hearing aid system.

A method of manufacturing a hearing aid system:

[0068] A method of manufacturing a hearing aid system is moreover provided by the features of the claims.

[0069] The features of the hearing aid system and of the method of adapting a hearing aid system described above, in the detailed description and in the claims are - where appropriate - intended for being combined with the present method of manufacturing a hearing aid system.

[0070] Further objects of the invention are achieved by the embodiments defined in the dependent claims and in the detailed description of the invention.

[0071] As used herein, the singular forms "a," "an," and "the" are intended to include the plural forms as well, unless expressly stated otherwise. It will be further understood that the terms "includes," "comprises," "including," and/or "comprising," when used in this specification, specify the presence of stated features, integers, steps, operations, elements, and/or components, but do not preclude the presence or addition of one or more other features, integers, steps, operations, elements, components, and/or groups thereof. It will be understood that when an element is referred to as being "connected" or "coupled" to another element, it can be directly connected or coupled to the other element or intervening elements maybe present. Furthermore, "connected" or "coupled" as used herein may include wirelessly connected or coupled. As used herein, the term "and/or" includes any and all combinations of one or more of the associated listed items.

BRIEF DESCRIPTION OF DRAWINGS

[0072] The invention will be explained more fully below in connection with a preferred embodiment and with reference to the drawings in which:

FIG. 1 shows the forward path of an exemplary hearing aid (FIG. 1a), the forward path and an electrical feedback cancellation path of an exemplary hearing aid (FIG. 1b), and a part of a hearing aid comprising an Online Feedback Manager (OFBM) according to an embodiment of the invention (FIG. 1c).

FIG. 2 shows a loop gain vs. normalized frequency curve for a hearing aid according to an embodiment of the invention comprising an online feedback manager unit OFBM1 used as an AFB system *without* a dedicated DFC system.

FIG. 3 shows a loop gain vs. normalized frequency curve for a hearing aid according to an embodiment of the invention comprising an online feedback manager unit OFBM1 used as an AFB system *combined* with a DFC system.

FIG. 4 shows a loop gain vs. normalized frequency curve for a hearing aid according to an embodiment of the invention comprising an online feedback manager unit OFBM2 used as feedback limiter.

FIG. 5 shows a loop gain vs. normalized frequency curve for a hearing aid according to an embodiment of the invention comprising an online feedback manager unit OFBM3 used as feedback optimizer in a case of too low maximum gain.

FIG. 6 shows a loop gain vs. normalized frequency curve for a hearing aid according to an embodiment of the invention comprising an online feedback manager unit OFBM3 used as a feedback optimizer in a case of too high maximum gain.

FIG. 7 is a sketch of different settings of the maximum forward gain G_{\max} vs. frequency.

FIG. 8 shows the influence of maximum feedback gain FBG_{\max} on insertion gain IG (here shown in a continuous picture; in practice the frequency range is divided into a number of bands as illustrated in FIG. 7), where IG is automatically adjusted according to FBG_{\max} . The resulting IG is represented by thick lines.

FIG. 9 illustrates a situation where more gain is supplied to the user, when the OFBM is updated resulting in an *increase* in FBG_{\max} or (IG_{\max}).

FIG. 10 illustrates a situation when the OFBM is updated resulting in a *decrease* in FBG_{\max} or (IG_{\max}).

FIG. 11 shows an example of daily varying FBG_{\max} or IG_{\max} as found by an embodiment of the fast OFBM according to the invention. Examples of maximum (upper solid curve) and minimum limits (lower solid curve) of FBG_{\max} (as e.g. allowed by an audiologist) are indicated. The dotted curve may represent FBG_{\max} or IG_{\max} as determined by an automated procedure during fitting (e.g. by a software programming tool).

FIG. 12 shows a block diagram of a part of an embodiment of a hearing aid comprising an OFBM according to the present invention.

FIG. 13 illustrates the combined effects of a fast and slow OFBM according to an embodiment of the present invention. Upper curves represent FBG_{\max} or IG_{\max} when initially or preliminary fitted or estimated (dotted curve) and accepted maximum (max, high) and minimum (max, low) limits e.g. as determined by an audiologist (solid curves). Lower curves represent FBG_{\max} or IG_{\max} after some time (weeks and months) also with maximum and minimum limits.

[0073] The figures are schematic and simplified for clarity, and they just show details which are essential to the understanding of the invention, while other details are left out. Throughout, the same reference numerals are used for identical or corresponding parts.

[0074] Further scope of applicability of the present invention will become apparent from the detailed description given hereinafter. However, it should be understood that the detailed description and specific examples, while indicating preferred embodiments of the invention, are given by way of illustration only.

MODE(S) FOR CARRYING OUT THE INVENTION

[0075] Fig. 1 shows the basic components of a hearing aid system 100.

[0076] Fig. 1a illustrates the forward path and an (unintentional) acoustical feedback path of a hearing aid. In the present embodiment, the forward path comprises an input transducer for receiving an acoustic input from the environment, an *AD*-converter, a processing part *HA-DSP* for adapting the signal to the needs of a wearer of the hearing aid, a *DA*-converter (optional) and an output transducer for generating an acoustic output to the wearer of the hearing aid. The intentional forward or signal path and components of the hearing aid are enclosed by the dashed outline denoted 100. An (external, unintentional) acoustical feedback path *ACFB* from the output transducer to the input transducer is indicated.

[0077] Fig. 1b illustrates a hearing aid as in Fig. 1a, *additionally* comprising an electrical feedback cancellation path for reducing or cancelling acoustic feedback from an 'external' feedback path from output to input transducer of the hearing aid. Here the electrical feedback cancellation path comprises an adaptive filter, which is controlled by a prediction error algorithm, e.g. an LMS (Least Means Squared) algorithm, in order to predict and cancel the part of the microphone signal that is caused by feedback from the receiver of the hearing aid. The adaptive filter (in Fig. 1b comprising a 'Filter' part and a prediction error 'Algorithm' part) is aimed at providing a good estimate of the 'external feedback path' from the input of the *DA* to the output from the *AD*. The prediction error algorithm uses a reference signal together with the microphone signal to find the setting of the adaptive filter that minimizes the prediction error when the reference signal is applied to the adaptive filter. The forward path (alternatively termed 'signal path') of the hearing aid comprises signal processing (termed '*HA-DSP*' in Fig. 1b) to adjust the signal to the (possibly impaired) hearing of the user.

[0078] The functional parts of the present invention preferably form part of the loop constituted by the forward path and the electrical feedback path and can e.g. be an integral part of the processing unit (*HA-DSP* in Fig. 1b) or the adaptive filter (possibly all located on the same integrated circuit). Alternatively, they may be implemented partially or fully separate there from.

[0079] FIG. 1c shows a part a hearing aid comprising an Online Feedback Manager (OFBM) according to an embodiment of the invention. FIG. 1c illustrates a forward path comprising a

forward gain block $G(z)$ defining a maximum gain, an acoustical feedback path comprising a feedback contribution $H(z)$, and a feedback path comprising an adaptive filter for calculating an estimate $H'(z)$ of the acoustical feedback, the latter e.g. forming part of a conventional DFC system. The OFBM uses the feedback path estimate from the DFC system to calculate the maximum forward gain. The forward gain is calculated by the compression system.

[0080] FIG. 7 is a sketch of different settings of the maximum forward insertion gain IG_{\max} vs. frequency f (or frequency band FB_i , $i=1, 2, \dots, 8$) of the processor of a hearing aid system for the frequency range $[f_{\min}; f_{\max}]$ between a minimum frequency f_{\min} and a maximum frequency f_{\max} . In practice f_{\min} can be between 5 and 50 Hz, e.g. 20 Hz and f_{\max} between 8 kHz and 25 kHz, e.g. 12 kHz and the number of frequency bands alternatively be 4 or 16 or 24 or 32 or 64 or 128 or larger.

[0081] The graph $IG_{\max\text{-std}}$ indicates a standard setting of the maximum forward gain for the different frequency bands, such as e.g. the (relatively conservative) setting of a hearing aid system directly from the manufacturer. $IG_{\max\text{-FBM}}$ indicates a setting of maximum forward gain, such as e.g. adapted by an audiologist using an offline 'feedback manager' (or using an automated procedure, e.g. a software tool running on a PC) to adjust the settings to a hearing profile of a given user. The graphs $IG_{\max\text{-OFBM}}(t_n)$ schematically indicate stored values of the maximum forward gain for each frequency band at time t_n as suggested by the present invention, here indicated by times t_1, t_2, t_3 .

[0082] The feedback limits in a hearing aid can be defined by the IG_{\max} (maximum insertion gain) parameters. A total of N IG_{\max} parameters are available - one for each frequency band, where N is the number of frequency bands. For each parameter both the target value and a fade-rate can be defined (the target value being the $IG_{\max,i}(t_n)$ value determined by the OFBM at a given point in time t_n , and the fade-rate being the rate FR_i (for the i^{th} frequency band) at which currently applied $IG_{\max,i}(t_{n-1})$ (appropriately faded) values converge ('fades') towards the target value $IG_{\max,i}(t_n)$. The feedback limits FBG_{\max} (and thereby the IG_{\max} parameters) are typically defined during the fitting process - either as pre-scribed values based on the hearing loss of a wearer or otherwise estimated. The feedback values applied are often a rather conservative estimate, and are typically several dB below the actual feedback limit, in order to account for variations in the user environment. The use of an OFBM according to the present invention enables the use of less conservative estimates and thereby extending the fitting range of the hearing aid.

[0083] The idea behind the OFBM is to control the FBG_{\max} (or IG_{\max}), which is used to limit insertion gain (IG) available for the wearer of the hearing aid according to the current user situation. Typically feedback (FB) occurs at high frequencies, so when e.g. the wearer or a dispenser increases the IG (by means of e.g. the volume control), then it will automatically be limited according to the IG_{\max} parameters. This fact is illustrated in FIG. 8 showing the

resulting IG, partly as prescribed IG ($IG_{\max\text{-std}}$), and partly as individual IG ($IG_{\max\text{-FBM}}$), if the wearer wishes more gain than prescribed. The OFBM will continuously update the FBG_{\max} according to the user situation.

[0084] The OFBM may change FBG_{\max} (or IG_{\max}) in direction of *more* gain, see FIG. 9. The consequence may be that gain for the user will be higher. It should be noted, though, that this is not necessarily of benefit in *all* situations since more gain make sounds become more dominating and perhaps with poor sound quality since headroom (compression and Maximum Power Output (MPO)) is not increased in same manner. Therefore, the audiologist needs to define an upper limit for the FBG_{\max} or IG_{\max} of the OFBM (not shown in FIG. 9).

[0085] On the other hand the OFBM may *decrease* FBG_{\max} or IG_{\max} , for example when the ear mould is not mounted correctly in the ear, see FIG. 10. The gain available for the user may be so low that some sounds become inaudible. To prevent this situation, a minimum limit for FBG_{\max} or IG_{\max} of the OFBM can be implemented (not shown in FIG. 10). In certain situations the OFBM may not be able to suppress the howling due to this minimum limit, but the occurrence of howl will remind the user or the care keeper to reinsert the ear mould in a correct manner.

[0086] Based on the requirements of upper and lower limits for FBG_{\max} (e.g. as determined by an audiologist's or an automated procedure), the allowable area for the FBG_{\max} variation of a fast OFBM according to an embodiment of the present invention is schematically illustrated in FIG. 11.

[0087] FIG. 12 schematically shows a block diagram of parts of an embodiment of a hearing aid system 100 comprising an anti feedback system (AFB) 110 and an OFBM (comprising a Fast OFBM 150 and a Slow OFBM 160) according to the present invention. The *Fast* OFBM 150 uses input 111 from the AFB-system 110 (e.g. loop gain calculation, feedback and leak detection) to calculate (' IG_{\max} CTRL' in FIG. 12) new target values and fade rates 151 for the N (e.g. 16) IG_{\max} parameters in the gain block (' IG_{\max} ' in FIG. 12) of the signal processor. The *Slow* OFBM 160 continuously logs ('Logging' in FIG. 12) the correction of IG_{\max} from the fitted values and calculates a time average for each of the N (e.g. 16) frequency bands. These average values 161 are then used to update the target values for IG_{\max} , here shown as signals 162 from a 'Learning' module to the IG_{\max} CTRL-block. Optional detectors 170 (e.g. directionality detector, mode detector, volume control, acoustic environment detector, location detector, etc.), which may form part of the hearing aid system 100 or be external to the hearing aid system are shown providing inputs 171 to the Fast and/or Slow OFBM units. In FIG. 12 a Fast and Slow OFB are shown to work in cooperation. Alternatively each of them may be used alone. The hearing aid system 100 is shown to be connectable to an external 'offline' FeedBack Manager 200 ('FBM' in FIG. 12), e.g. indicating a software tool (e.g. run on a PC) of an audiologist for making a fitting of the hearing aid system to a wearer's needs. Data 163 from the logging system of the Slow OFBM 160, including logged IG_{\max} values for each frequency

band and for a number of different points in time may be forwarded to the FBM for further analysis. Optional connection 201 is indicated for forwarding data from the FBM to the OFBM, e.g. preset values $IG_{\max\text{-FBM}}$ to IG_{\max} CTRL-block of the (fast) OFBM via the Learning-block of the (slow) OFBM. The communication between the hearing aid system 100 and optional external detectors 170 or programming units 200 or other devices may be wired or wireless and based on electrical or optical signals.

[0088] If the average correction exceeds a certain threshold, indications could be given to the wearer in the form of beeps or blinks.

[0089] As indicated in FIG. 12, the OFBM can be adapted to accept inputs from other detectors in the system in order to obtain the desired functionality.

[0090] Each of the three OFBM blocks will be treated separately in the following sections.

Fast OFBM with AFB

[0091] The fast OFBM is a system that updates IG_{\max} , e.g. once every second. If the update speed becomes much slower (e.g. more than 5 - 10 s) interaction from other automatic features in the HA (directional microphone system, learning modes, etc.) will influence the OFBM performance.

Core OFBM system:

[0092] The Fast OFBM works more or less the same way as a feedback manager of a software programming tool, such as e.g. used by an audiologist when adapting a hearing instrument to a particular wearers needs. It attacks the problem that causes AFB problems directly; namely the loop gain. Loop gain is the sum of the gain in the feedback path and the gain in the signal path and when this value gets too large, the HA starts to sound "bad", and when the value surpasses 0 dB, the HA is likely to howl. The goal of the OFB is to keep the AFB within the interval of loop gains that can be handled by the AFB system.

[0093] The resulting, frequency (f) dependent, loop gain LG is essentially calculated as follows:
 $LG(f) = H_{DFC}(f) + H_{SP}(f)$

where H_{DFC} is the feedback estimate of the AFB-system, H_{SP} is the signal processor gain. The practical implementation of the H_{DFC} and H_{SP} transfer functions can comprise FIR- or IIR-filters or any other appropriate components.

[0094] A method which will restrict loop gain to a specified maximum value can be implemented. Such a method both prevents feedback howls from occurring and eliminates feedback howls after they occur and comprises: a) In a static situation, determine (in each

frequency interval) the critical (maximum) loop gain to avoid howling LG_{howl} , which can be handled by the AFB system. b) Decide an appropriate gain margin in each frequency band and subtract this value from corresponding LG_{howl} values, resulting in values for the maximum allowed loop gain LG_{max} for each frequency band. To enforce this loop gain we would then perform the following steps for each of the 16 frequency intervals.

1. The maximum gain in the AFB FIR filter for the frequency interval is determined. We will call this value AFB_{max} .
2. From this value we can directly calculate the maximum value of IG_{max} to keep the AFB system operating within the desired loop gain interval. $IG_{\text{max}} = LG_{\text{max}} - AFB_{\text{max}}$. Preferably, threshold values restricting the interval wherein IG_{max} can be adjusted, are defined ($[IG_{\text{max,high}}; IG_{\text{max,low}}]$).

[0095] The value, which is calculated and applied to IG_{max} is applied to the target IG_{max} ; the actual IG_{max} used by the hardware, current IG_{max} , fades towards this value. This will keep the OFBM stable. The fade rates should preferably be adjusted so that the OFBM can reduce gain relatively quickly and increase gain over a longer time interval.

Parameters for the Fast OFBM system

[0096] To configure the Fast OFBM system the following parameters will be introduced.

Name	Values	Description
ofbmon	1:0	Global OFBM enabled/disabled
Ofbmaxactive.[1 :16]	1:0	OFBM enabled/disabled in each frequency band. Ignored if ofbmon = 0.
max_igmax_t hresholds.[1:1 6]	0:96 dB	Maximum allowed value for target IG_{max} in each frequency band where OFBM is enabled.
min_igmax_t hresholds .[1:16]	0:96 dB	Minimum allowed value for target IG_{max} in each frequency band where OFBM is enabled.
max_loopgain . [1:16]	-48:48 dB	The maximum allowed loop gain in each frequency interval.
delta_howl_att en . [1:16]	0:96 dB	How much to reduce IG_{max} by instantaneously in frequency band with positive tone detection.
leak_hold_ofb m_time	0:255	How many seconds the OFBM should be paused after a leak has occurred.

[0097] In addition, it will be possible to adjust the fade rates up/down in IG_{max} .

Slow OFBM (in addition to a Fast OFBM)

[0098] The slow OFBM continuously logs data from the Fast OFBM and uses this as input to a learning routine. As the name suggests the adaptation of the Slow OFBM is much slower than the Fast OFBM. However, the adjustments made to IG_{max} may be greater than what the Fast OFBM does.

[0099] In cases where an ear mould becomes loose in the ear (the ears of a child grow or the ear mould becomes smaller during time etc.), it may be acceptable to reduce both the upper and lower limit of FBG_{max} (or IG_{max}), cf. FIG. 11. This is illustrated in FIG. 13. However, a requirement of this reduction is that it is slow in time (i.e. corresponds to the growth of a child ear, for example maximum reduction of 2 dB a week).

[0100] FIG. 13 illustrates the combined effects of a fast and slow OFBM according to an embodiment of the present invention. Upper curves represent FBG_{max} or IG_{max} when initially or preliminary fitted or estimated (dotted curve) and accepted maximum and minimum limits e.g. as determined by an audiologist (solid curves). Lower curves represent FBG_{max} or IG_{max} after some time (weeks and months) also with maximum and minimum limits. The difference between upper and lower curves is due to an adaptation process of the slow OFBM, and the gain change velocity (dB/week) of the adaptation is specified by the audiologist (e.g. maximum gain reduction of 1 dB/week, such as 2 dB a week, such as 3 dB/week).

Parameters for the Slow OFBM system

[0101] The slow OFBM system is based upon input from a statistical surveillance of the fast OFBM system. It can advantageously be applied in connection with ear moulds for children, which gradually become too small. Contrary to a wrongly inserted ear mould, this condition will be handled by the fast OFBM as long as it can reduce gain within the allowed attenuation limit $min_igmax_thresholds$ (cf. table above). However, as the mould gets looser, a further reduction may be needed as well as a decreased $default_igmax_threshold$ (cf. e.g. dotted line in FIG. 13). The default values and lower limit values would then be updated with new settings (both saved in a memory, e.g. an EEPROM, of the system). The upper limits/gain margin is preferably also be updated towards less allowed IG_{max} .

[0102] Thus, if the adjustments made by the fast OFBM are often truncated by the limits, this will be identified by the slow OFBM, and action is taken:

- The default settings will be updated in accordance with predefined rules (cf. examples below). In this way the fast OFBM does not have to compensate for this in the future.
- It may be relevant to allow the system also to increase limits, in cases where too

conservative values have been applied to be sure to avoid howl.

- Information may be passed on to a warning system that is responsible for notifying the user or another relevant person about the problem.

[0103] Depending on the application (product) it may be relevant to let the Slow OFBM interact with the Fast OFBM in *different* ways. Therefore the system is preferably configurable so that it can selectably:

- use same or different learning steps in the different frequency bands, i.e. change the entire IG_{\max} response curve individually or adjust all bands equally.
- let the system be open to band specific learning (in OFBM enabled bands). This can be used to influence soft gain response and sound quality.
- use band specific learning with dynamic range constraints.

Time constants of the slow OFBM?

[0104] In an embodiment, the slow OFBM only updates EEPROM settings (e.g. `default_igmax_threshold`), i.e. the effect of the slow OFBM is only applied to the gain path after a boot of the processor or a program change. User information may be given at any time, i.e. not only at start-up.

[0105] The slow OFBM may be considered equivalent to an audiologist renewing the fitting once at a week. It has the advantage of avoiding a time consuming refitting by an audiologist, which is in general would not be practical at such a high frequency.

[0106] A wearer, at least one with severe/profound hearing loss, is assumed to use the hearing aid every day, and therefore reboots the hearing aid system every morning or when being aided with the hearing aid. Accordingly, the wearer will not notice immediately the gain change (e.g. with max 2 dB change a week since this would correspond to

$$\frac{1}{3}$$

dB change a day). Information from a wearer may be fed into the system.

[0107] One or more of the following parameters are preferably added for improved function of the slow OFBM:

- Maximum rates of adaptation in upwards and downwards direction (e.g. 2 dB a week).
- Step sizes of adaptation.
 - Use of different values in the different bands.

- Dispensers'/audiologist's accept of increasing IG_{\max} above FBG_{\max} as determined by an automatic procedure or a predefined setting (a yes/no parameter). Here an upper limit of IG_{\max} can be included (= `max_igmax_thresholds`, see table above) for preventing extreme increases.
- User information to warn about the system consequently turning down (or up) limits.

Rules

[0108] The default settings of gain characteristics of the hearing aid are preferably updated in upwards or downward direction in accordance with predefined rules in dependence on selected learning principles.

Same learning in all bands:

[0109] In an embodiment, a histogram of the number of bands truncated by a limit at each update for the fast OFBM is produced. This histogram represents the likelihood of a given number of bands in need for a larger IG_{\max} change than allowed. If the histogram median is high (larger than a predefined value), a learning update is needed. Learning updates and histogram scaling (forgetting) are preferably done at regular (predefined) intervals in time. Separate histograms for upwards and downwards learning are preferably produced.

Band specific learning:

[0110] Here, the average IG_{\max} changes relative to the default value for each band are logged. If the average exceeds a predefined threshold value, a learning step is performed, if it is within (predefined) dynamic range constraints of other (e.g. adjacent) bands. Learning-updates and average scaling (forgetting) are preferably done at regular (predefined) intervals in time.

Example 1. OFBM1, use of an OFBM as an AFB-svstem:

Standalone:

[0111] The OFBM1 is able to work as an (standalone) AFB system, if the target (predefined gain limit) for the OFBM1 is < 0 dB loop gain and the system has a relatively fast update speed

of e.g. 100 ms (i.e. an update frequency around 10 Hz). The closer the target loop gain is to 0 dB the faster a system is needed (the higher the update frequency). If the target is below 0 dB loop gain, the DFC system can be bypassed and only used for estimating the feedback path (cf. FIG. 2).

[0112] FIG. 2 shows a loop gain vs. normalized frequency curve for a hearing aid according to an embodiment of the invention comprising an online feedback manager unit OFBM1 used as an AFB system without a dedicated DFC system. The normalized frequency range corresponds to a real frequency range of e.g. 20 Hz to 12 kHz. The OFBM1 system uses the feedback estimate to control the maximum gain of the feedback loop. The DFC is not needed, because the feedback is removed by gain reduction. A slower system (lower update frequency) needs a lower threshold (lower predefined gain limit).

Combined with existing DFC-system:

[0113] Fig. 3 shows a loop gain vs. normalized frequency curve for a hearing aid according to an embodiment of the invention comprising an online feedback manager unit OFBM1 used as an AFB system combined with a DFC system. If the target (predefined gain limit) is *above 0 dB loop gain*, the DFC system is still needed, but the working interval of the OFBM will be constrained to a predefined loop gain limit, e.g. maximum 3 dB loop gain, because the OFBM1 will continuously (i.e. with a certain update frequency) reduce the forward gain to 3 dB loop gain (cf. FIG. 3). Above the threshold, feedback is removed by gain reduction. Between 0 dB loop gain and the threshold, feedback is removed using the DFC.

[0114] In this setup the OFBM will work as a stand-alone AFB system (if the target is < 0 dB and the DFC system is used for feedback estimation only) or as a parallel system to the DFC system (if the target is > 0 dB loop gain). In both setups the OFBM1 will have a major impact on the forward gain and will depend on a reliable feedback path estimate from the DFC system.

[0115] Using the OFBM as a parallel AFB system opens up for interactions between the DFC system and the OFBM. The OFBM1 will reduce the gain where the loop gain is above the limit, and reducing the gain will make it more difficult for the DFC system to estimate the feedback path in that region. The OFBM will always be slower than the DFC system and will decrease the gain after the DFC system has estimated the feedback path and removed the feedback signal.

Implementation:

[0116] The coefficients from the DFC system are used to calculate the frequency response in a processor and from the frequency response the maximum feedback in each band are found.

This maximum feedback determines the maximum gain in the forward path.

[0117] In an embodiment, the OFBM is constrained to a predefined maximum allowed change per update, e.g. only allow +/- 2 dBs of change.

Example 2. OFBM2, use of an OFBM as a feedback limiter:

[0118] The OFBM can be used to limit the maximum loop gain. The working interval for the DFC system is from $-\infty$ dB to $+\infty$ dB loop gain. This interval is difficult to handle, and it is well known that a working interval from about 0 dB to 12 dB loop gain is the optimum for the DFC system. Using the OFBM to limit the maximum loop gain ensures that the DFC system will not be pushed too much: If the loop gain increases above the limit (predefined gain limit), the forward gain will be reduced and thus increase the ability for the DFC system to remove the feedback. This can be seen as changing the working interval for the DFC from $-\infty$ dB to $+\infty$ dB loop gain to e.g. $-\infty$ dB to a predefined gain limit, here +12 dB loop gain (cf. FIG. 4). FIG. 4 shows a loop gain vs. normalized frequency curve for a hearing aid according to an embodiment of the invention comprising an online feedback manager unit OFBM2 used as feedback limiter. If the loop gain exceeds the threshold (predefined gain limit), the gain is reduced.

[0119] In this setup, the OFBM will only be active in situations where the user will experience artefacts and bad sound quality, because of too high loop gain and a DFC system that is pushed too hard. The gain will be reduced but only in situations where the user has no need of it.

[0120] The OFBM2 is not dependent on a reliable estimate each 100 ms, but can wait to certain requirements are fulfilled, such as a minimum variation in the feedback estimate, detectors, or similar indicators of the reliability of the estimated feedback.

[0121] External tones in a given frequency band will increase the feedback path estimate thus decreasing the max gain in that frequency band. This might be a problem: When the tone stops, we want as much gain in that region as possible to get a reliable estimate. A similar situation can occur, when a telephone receiver is placed at the ear: The feedback path increases with e.g. 14 dB between 3 and 4 kHz. This increase will make the OFBM2 reduce the forward gain in that frequency region. When the receiver is removed it might be difficult for a FCD to trigger because not much gain is found in the affected area. This problem can be diminished by defining a more flat max gain vs. frequency curve (i.e. not 'too peaky').

Example 3. OFBM3, use of an OFBM as a feedback optimizer:

[0122] The OFBM3 can be seen as an adaptive addition to the initial max gain IG_{\max} set

during an initial (or later) fitting procedure (e.g. by an audiologist). It is known that the feedback path will change over time as a result of the different conditions through the day or days. The target of the OFBM3 is to slowly update the max gain to follow these changes.

[0123] If the max gain is too low, the user has less gain than wanted and the DFC system has problems estimating the feedback path (cf. FIG. 5). Fig. 5 shows a loop gain vs. normalized frequency curve for a hearing aid according to an embodiment of the invention comprising an online feedback manager unit OFBM3 used as feedback optimizer in a case of too low maximum gain. The maximum gain is too restrictive, so the user might not get the wanted gain.

[0124] If max gain IG_{\max} is too high, it will be more difficult for the DFC system to handle quick and large increases in the feedback path (cf. FIG. 6). Fig. 6 shows a loop gain vs. normalized frequency curve for a hearing aid according to an embodiment of the invention comprising an online feedback manager unit OFBM3 used as a feedback optimizer in a case of too high maximum gain. If a sudden increase in the feedback path occurs, the loop gain can get too high for the DFC system.

[0125] The OFBM3 is based on the assumption that it is possible to get a reliable feedback estimate on average over time, e.g. several minutes (the update frequency is e.g. smaller than or equal to 0.01 Hz). If this assumption is met, the OFBM3 could relax the safety margin used when presetting the max gain of the hearing aid.

[0126] Compared to the other OFBM systems (OFBM1, OFBM2), OFBM3 updates $IG_{\max,i}$ continuously (i.e. with the predefined update frequency) independent of the loop gain LG_j . The other OFBM systems (OFBM1, OFBM2) only update $IG_{\max,i}$ when the loop gain exceeds a chosen threshold (predefined loop gain limit $LG_{\max,i}$).

[0127] The averaged estimated feedback path is affected by tonal input, small gain, or quick changes in the feedback path. The OFBM3 must take these problems into consideration. As opposed to the previously described OFBM systems, the OFBM3 will interact with changes in ADIR (ADIR = Adaptive DIRectionality = a functional block that shifts between an omni-directional mode (having a substantially equal sensitivity to sounds at all spatial angles) and a directional mode (having a better sensitivity at one or more preferred spatial angles (e.g. best sensitivity for sounds coming one angle, e.g. from in front). Shifts in the ADIR have time constants of the order of seconds, e.g. 3-4 s, so the OFBM is preferably able to accommodate such time constants (be fast enough).

[0128] Different max gains can be used in different ADIR modes so the OFBM3 should preferably be able to handle these changes.

[0129] The invention is defined by the features of the independent claim(s). Preferred embodiments are defined in the dependent claims. Any reference numerals in the claims are intended to be non-limiting for their scope. Some preferred embodiments have been shown in

the foregoing, but it should be stressed that the invention is not limited to these, but may be embodied in other ways within the subject-matter defined in the following claims.

REFERENCES

[0130]

US 5,619,580 (GN Danavox) 28-04-1994

US 6,219,427 (GN ReSound) 17-04-2001

WO 2006/063624 (WIDEX) 22-06-2006

REFERENCES CITED IN THE DESCRIPTION

Cited references

This list of references cited by the applicant is for the reader's convenience only. It does not form part of the European patent document. Even though great care has been taken in compiling the references, errors or omissions cannot be excluded and the EPO disclaims all liability in this regard.

Patent documents cited in the description

- US5619580A [0005] [0130]
- US6219427B [0006] [0130]
- WO2006063624A [0007] [0130]
- EP1191814A1 [0008]
- US20040136557A1 [0008]
- WO2007113282A1 [0008]

Patentkrav

- 5 1. Høreapparatsystem, der omfatter en indgangstransducer, en fremadgående vej, en udgangstransducer og en elektrisk tilbagekoblingsvej, hvor den fremadgående vej omfatter en signalbehandlingsenhed til at modificere et elektrisk indgangssignal til en specifik høreprofil over et foruddefineret frekvensområde, hvor det foruddefinerede frekvensområde omfatter et antal frekvensbånd, for hvilke maksimale fremadgående forstærkningsværdier IG_{max} for hvert bånd er lagret i en hukommelse, hvor den elektriske tilbagekoblingsvej omfatter et adaptivt filter til estimering af akustisk tilbagekobling fra udgangs- til indgangstransduceren, hvor 10 høreapparatsystemet yderligere omfatter en online tilbagekoblingsstyringsenhed til - med en foruddefineret opdateringsfrekvens - at identificere den aktuelle tilbagekoblingsforstærkning i hvert frekvensbånd af tilbagekoblingsvejen, og til efterfølgende at tilpasse de maksimale 15 fremadgående forstærkningsværdier IG_{max} i hvert af frekvensbåndene i afhængighed heraf i overensstemmelse med et foruddefineret skema, KENDETEGNET VED, AT opdateringsfrekvensen er tilpasset til en relevant høresituation baseret på en eller flere specifikke sensorer til klassificering af det nuværende miljø i form af eksterne signaler, der 20 videresender sådan information til høreapparatet.
2. Høreapparatsystem ifølge krav 1, hvor det foruddefinerede skema omfatter, at den maksimale fremadgående forstærkningsværdi for et frekvensbånd 25 udelukkende er tilpasset på basis af en aktuel maksimal tilbagekoblingsforstærkningsværdi for dette bånd.
3. Høreapparatsystem ifølge krav 1, hvor det foruddefinerede skema omfatter, at den maksimale fremadgående forstærkningsværdi for et frekvensbånd er 30 tilpasset således, at summen af en aktuel maksimal tilbagekoblingsforstærkning og de maksimale fremadgående forstærkningsværdier er mindre end eller lig med en foruddefineret maksimal sløjfeforstærkningsværdi for dette bånd.
- 35 4. Høreapparatsystem ifølge et hvilket som helst af kravene 1-3, hvor det foruddefinerede skema omfatter, at de maksimale fremadgående forstærkningsværdier for *alle* frekvensbånd er tilpassede.
- 40 5. Høreapparatsystem ifølge kravene 3 eller 4, hvor en foruddefineret maksimal sløjfeforstærkningsværdi er +10 dB, såsom +5 dB, såsom +2 dB, såsom 0 dB eller såsom -2 dB.
- 45 6. Høreapparatsystem ifølge et hvilket som helst af kravene 1-5, hvor det foruddefinerede frekvensområde ligger fra 20 Hz til 20 kHz, såsom fra 20 Hz til 12 kHz, såsom fra 20 Hz til 8 kHz.
7. Høreapparatsystem ifølge et hvilket som helst af kravene 1-6, hvor det foruddefinerede frekvensområde omfatter mindst 2 frekvensbånd, såsom

mindst 4, såsom mindst 8, såsom mindst 12, såsom mindst 16, såsom mindst 32 bånd.

5 8. Høreapparatsystem ifølge et hvilket som helst af kravene 1-7, hvor rækkefølgen af opdateringsfrekvensen ligger i området af et sekund, eller i området af et minut, eller i området af en time eller i området af en gang hver 10. time eller i området af en gang hver 100. time.

10 9. Høreapparatsystem ifølge et hvilket som helst af kravene 1-8, hvor opdateringsfrekvensen er større end eller lig med 0,001 Hz, såsom større end eller lig med 0,01 Hz, såsom større end eller lig med 0,1 Hz, såsom større end eller lig med 1 Hz, såsom større end eller lig med 10 Hz, såsom større end eller lig med 100 Hz, såsom større end eller lig med 1 kHz.

15 10. Høreapparatsystem ifølge et hvilket som helst af kravene 1-9, der omfatter eller består af et høreapparat.

20 11. Fremgangsmåde til at tilpasse et høreapparatsystem til varierende akustiske indgangssignaler, hvor høreapparatsystemet omfatter en indgangstransducer, der transformerer et akustisk indgangssignal til et elektrisk indgangssignal, en fremadgående vej, en udgangstransducer til at transformere et elektrisk udgangssignal til et akustisk udgangssignal og en tilbagekoblingsvej, hvor den fremadgående vej omfatter en signalbehandlingsenhed til at modificere et elektrisk indgangssignal til en
25 specifik høreprofil over et foruddefineret frekvensområde, hvor det foruddefinerede frekvensområde omfatter et antal frekvensbånd, der kan tilpasses individuelt, hvor tilbagekoblingsvejen omfatter et adaptivt filter til estimering af akustisk tilbagekobling fra udgangs- til indgangstransducere, hvilken fremgangsmåde omfatter

30 a) at identificere maksimal tilbagekoblingsforstærkning i hvert frekvensbånd,

b) at beregne sløjfeforstærkningen i hvert af frekvensbåndene baseret på tidligere lagrede værdier af maksimal fremadgående forstærkning og den maksimale tilbagekoblingsforstærkning,

35 c) at kontrollere, om sløjfeforstærkningen ligger over en vis maksimal sløjfeforstærkningsværdi i hvert frekvensbånd,

d1) hvis ja, *reduktion af* den maksimale fremadgående forstærkning i dette frekvensbånd,

40 d2) hvis nej, afhængig af en foruddefineret første OFBM-parameter, *forøgelse af* den maksimale fremadgående forstærkning ELLER fortsætte uden at ændre den maksimale fremadgående forstærkning i dette frekvensbånd,

e) lagring i en hukommelse af de nye værdier af den maksimale fremadgående forstærkning i hvert frekvensbånd,

45 f) gentagelse af algoritmen a) - e) med en foruddefineret opdateringsfrekvens, KENDETEGNET VED,

AT opdateringsfrekvensen er tilpasset til en relevant høresituation baseret på en eller flere specifikke sensorer til klassificering af det

nuværende miljø, idet eksterne signaler videregiver sådan information til høreapparatet.

- 5 12. Fremgangsmåde ifølge krav 11, hvor i trin d) den maksimale fremadgående forstærkning reduceres eller forøges med en foruddefineret mængde, for eksempel 0,5 dB, 1 dB eller 2 dB.
- 10 13. Fremgangsmåde ifølge krav 11 eller 12, hvor i trin d) den maksimale fremadgående forstærkning reduceres eller forøges til højst en forudbestemt brøkdel af den forudbestemte maksimale sløjfeforstærkningsværdi i hvert frekvensbånd.
- 15 14. Fremgangsmåde ifølge et hvilket som helst af kravene 11-13, hvor lagringen af mulige nye maksimale fremadgående forstærkningsværdier udføres ved samme eller ved en lavere frekvens end opdateringsfrekvensen.
- 20 15. Fremgangsmåde ifølge krav 14, hvor en lagringsfrekvens afhænger af, om der er sket en ændring af en værdi af et eller flere af frekvensbåndene siden den sidste kontrol.
- 25 16. Fremgangsmåde ifølge et hvilket som helst af kravene 11-15, hvor de maksimale forstærkningsværdier af den fremadgående vej IG_{\max} for et bestemt frekvensbånd i løbende opdateres med den foruddefinerede opdateringsfrekvens *uafhængigt* af en aktuel sløjfeforstærkning LG_i i båndet.

DRAWINGS

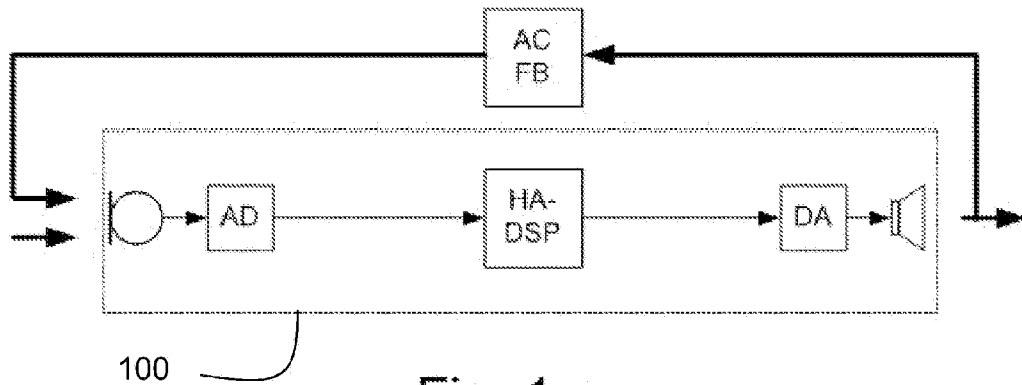

Fig. 1a

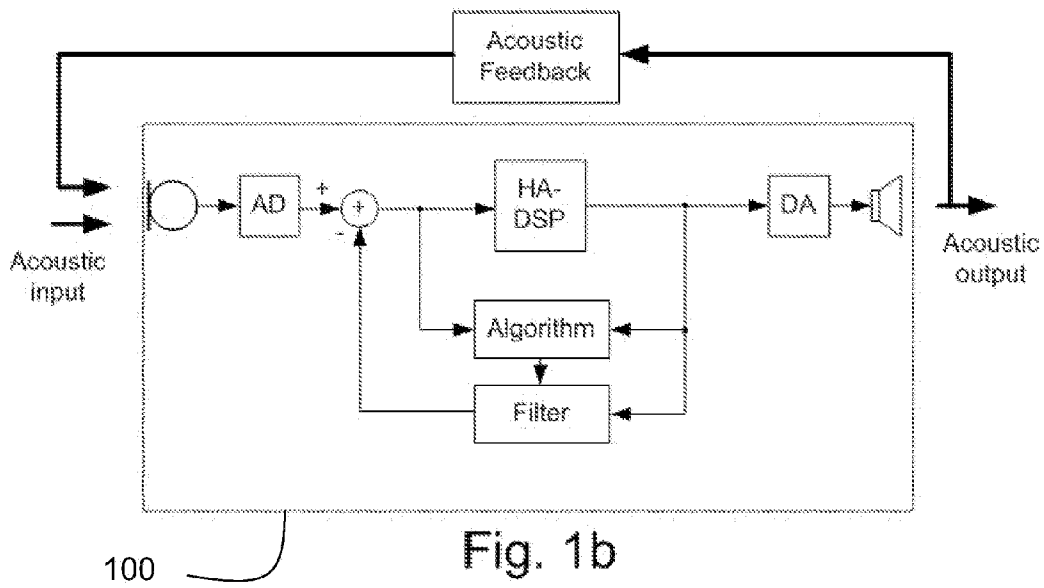

Fig. 1b

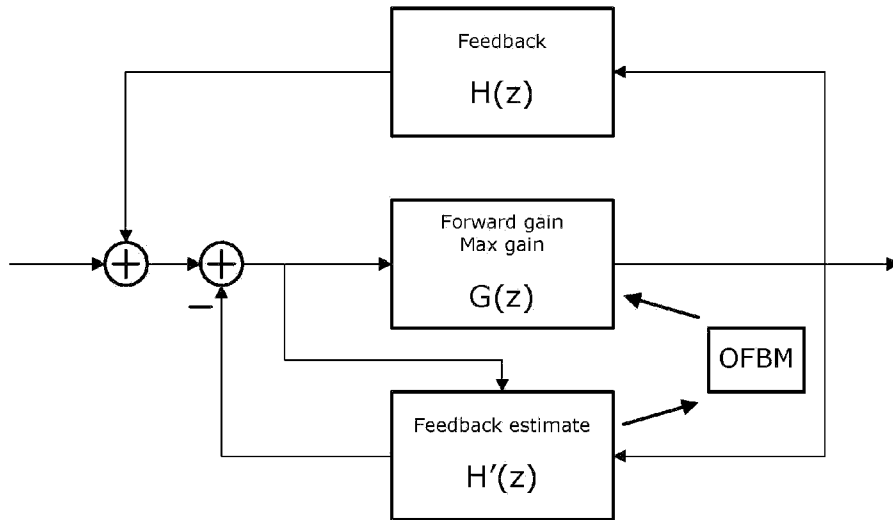

FIG. 1c

OFBM1 - without DFC

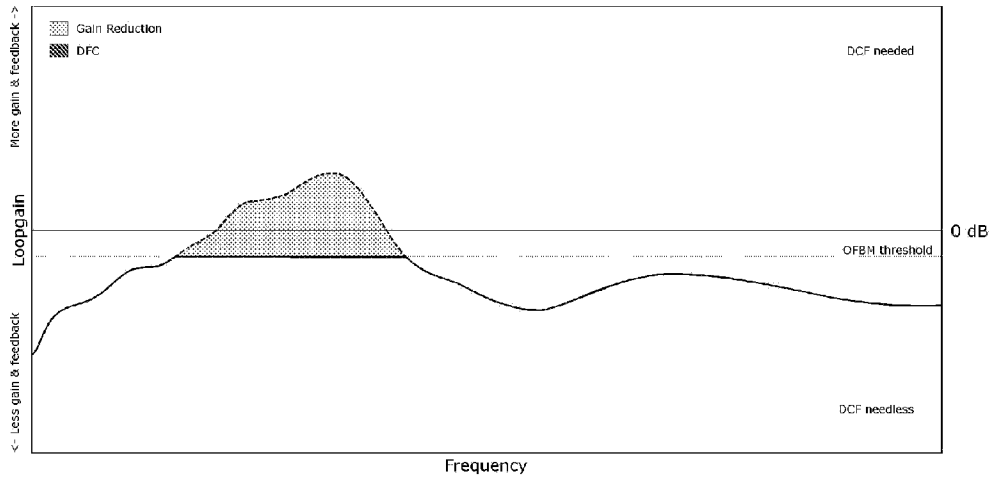

FIG. 2

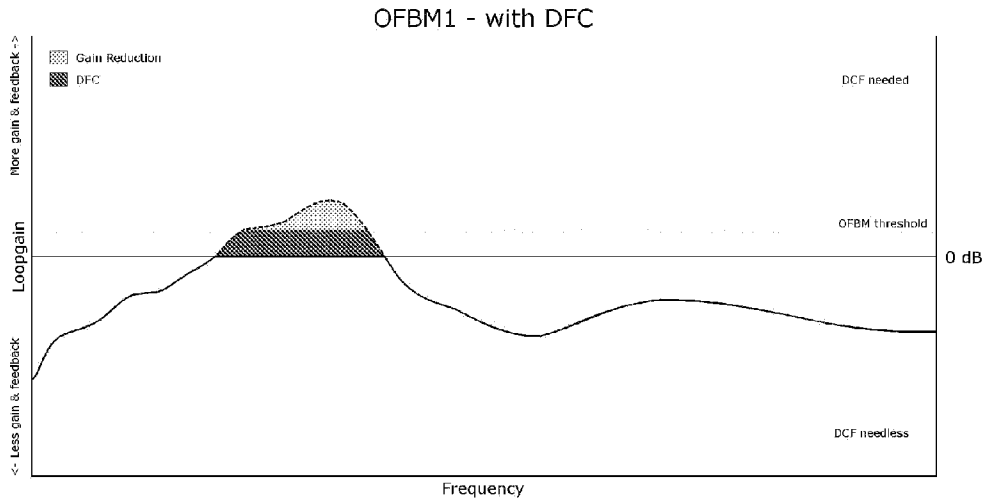

FIG. 3

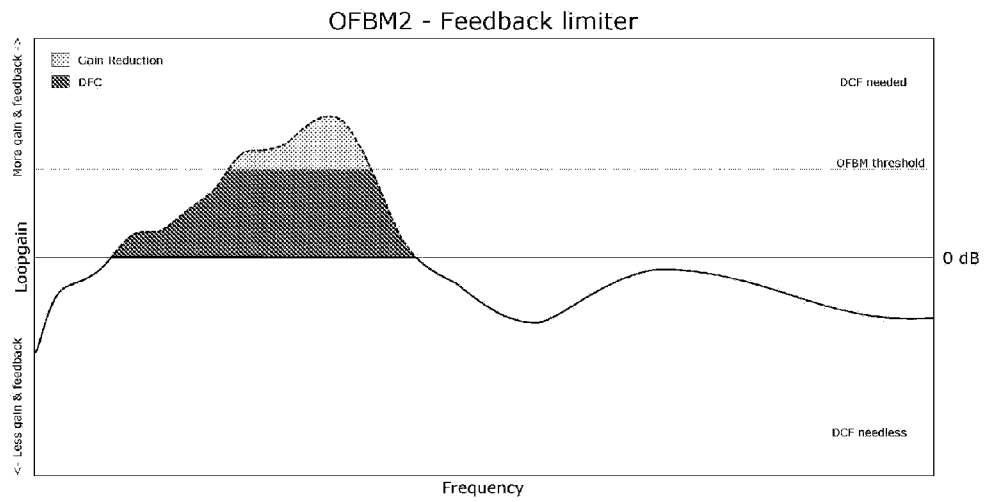

FIG. 4

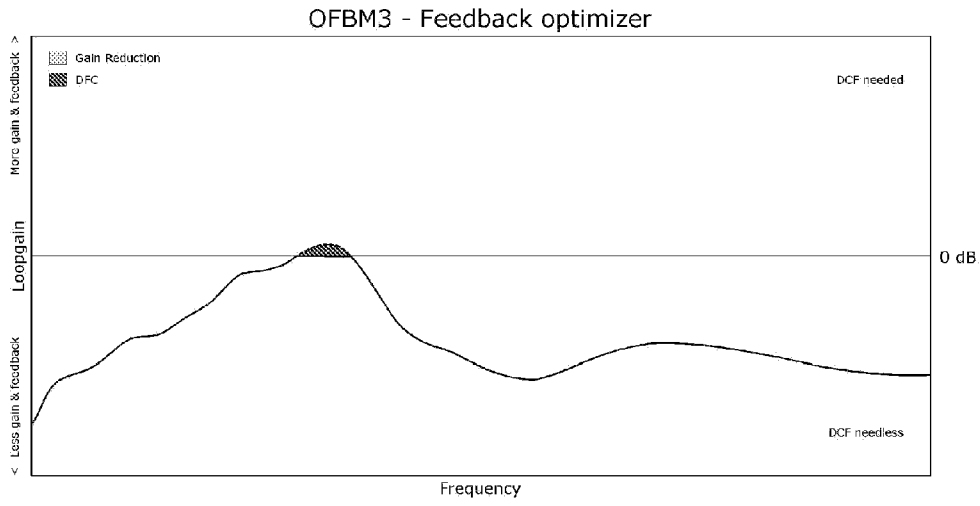

FIG. 5

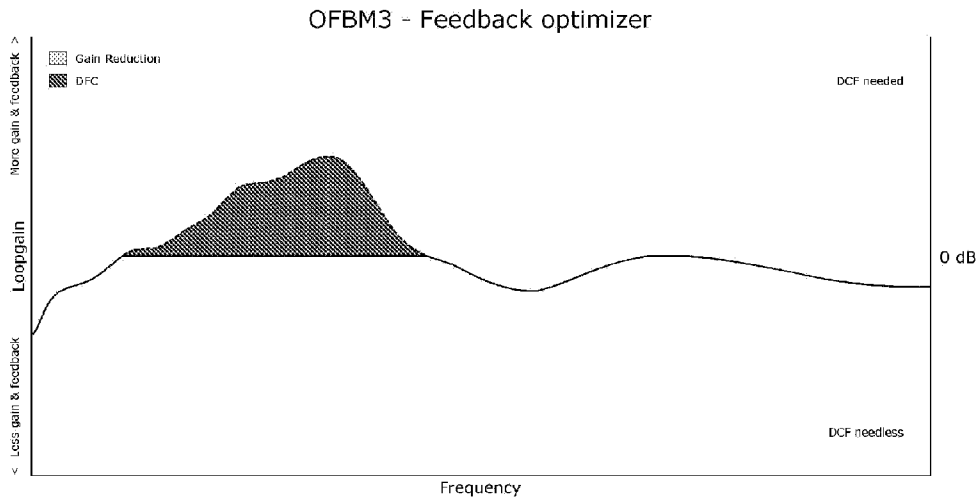

FIG. 6

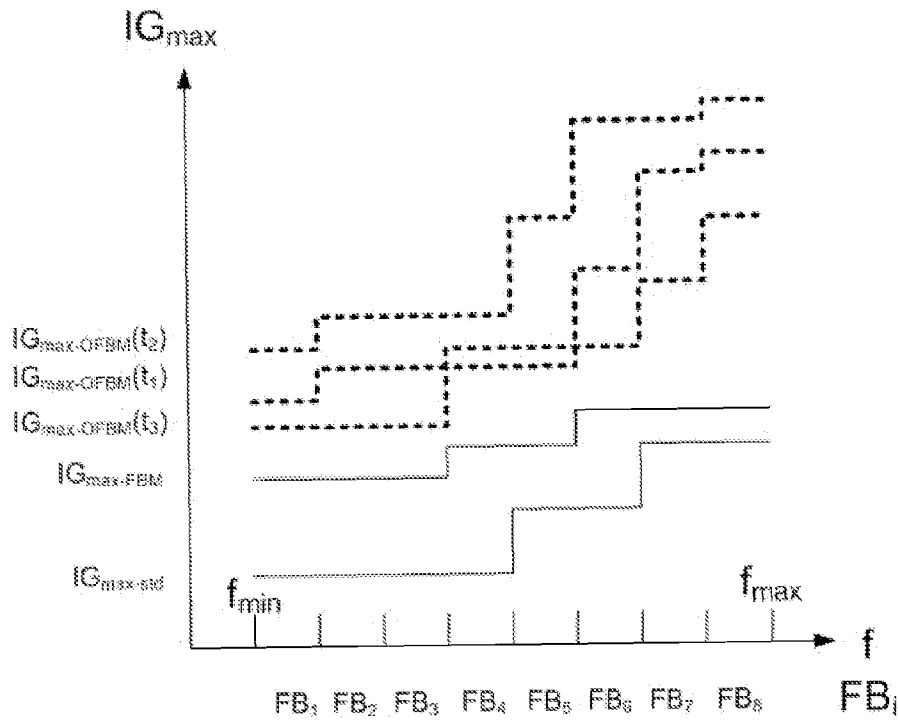

FIG. 7

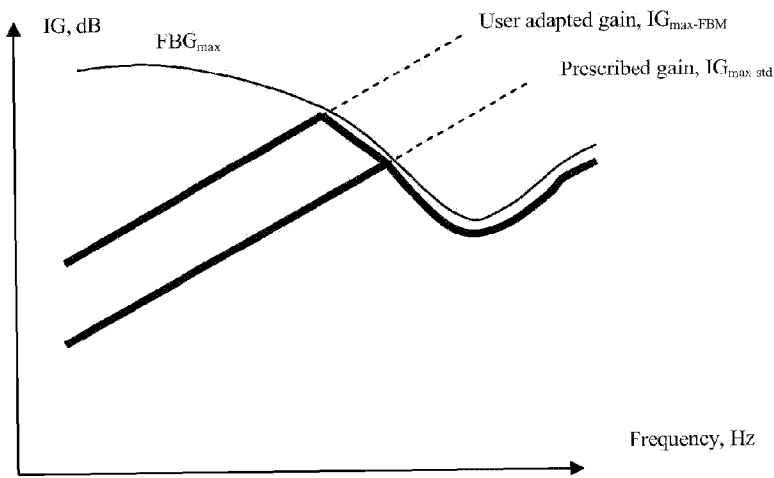

FIG. 8

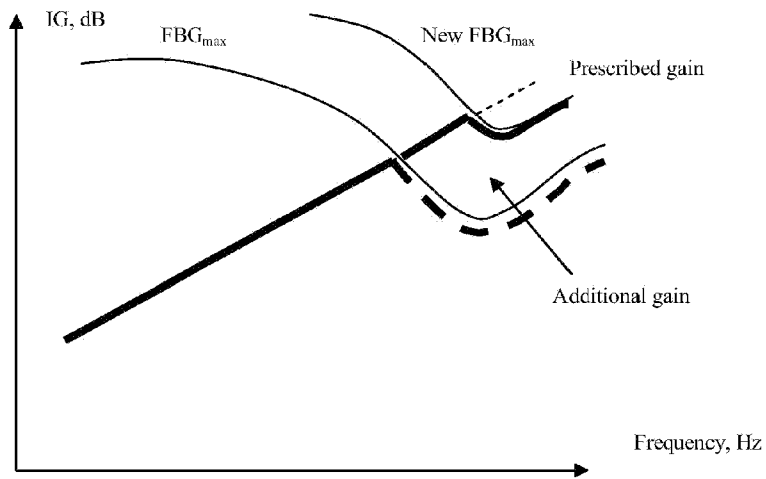

FIG. 9

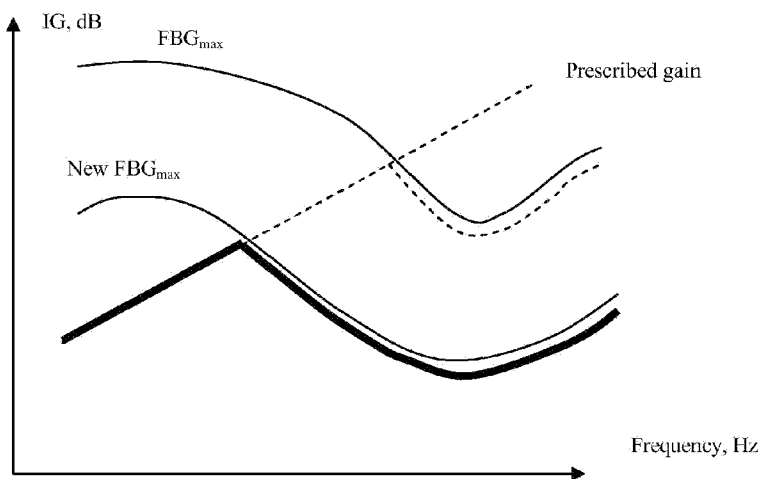

FIG. 10

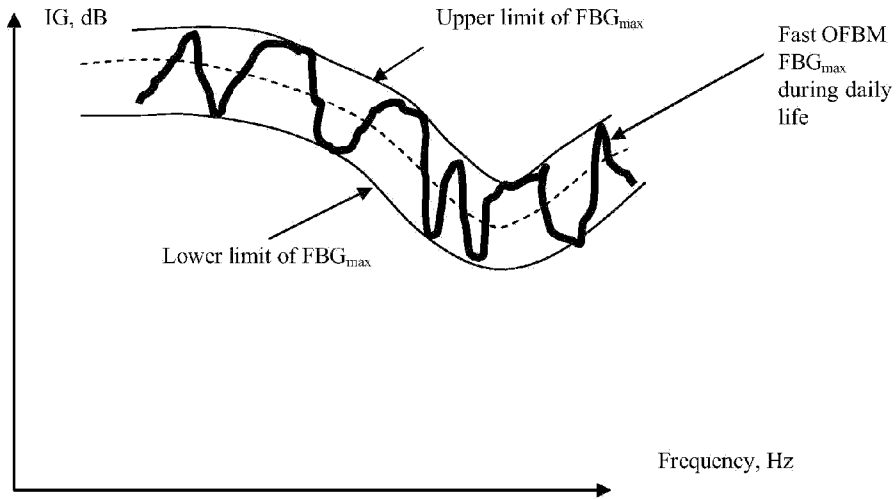

FIG. 11

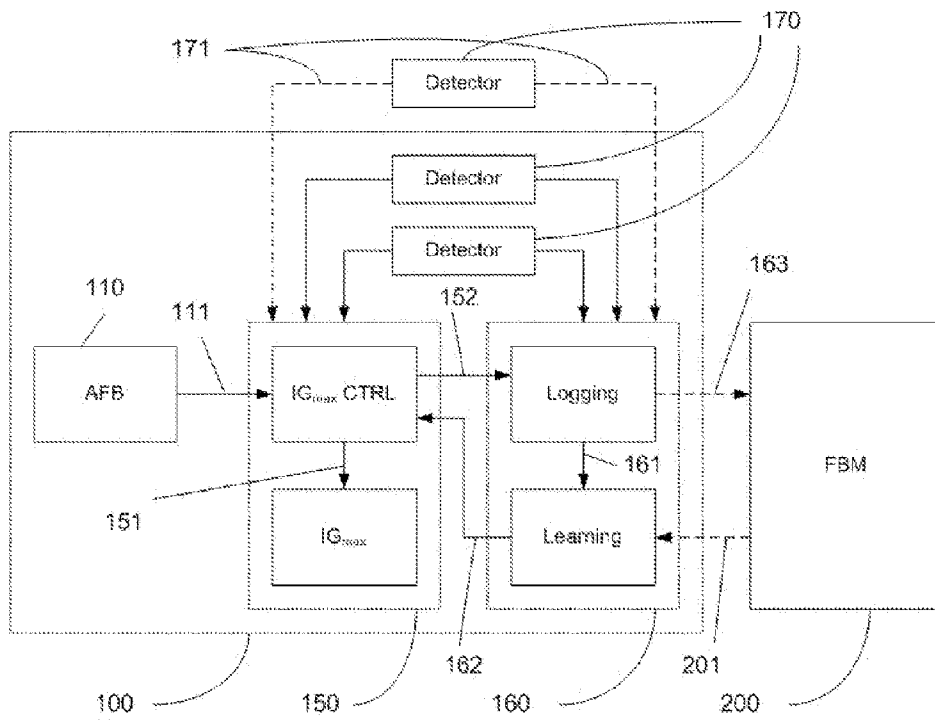

FIG. 12

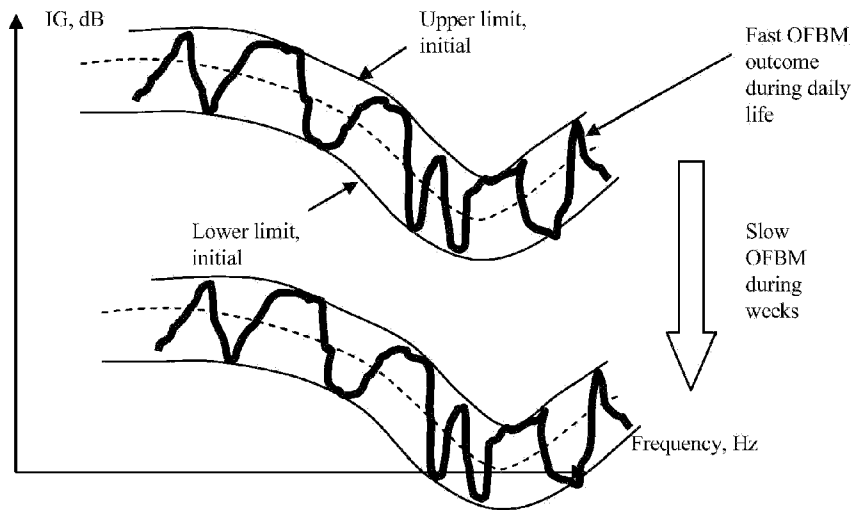

FIG. 13