

No. 739,760.

PATENTED SEPT. 22, 1903.

C. C. VERMEER.
APPARATUS FOR STORING AND UNLOADING MATERIALS.

APPLICATION FILED JUNE 24, 1903.

NO MODEL.

2 SHEETS—SHEET 1.

FIG. 1.

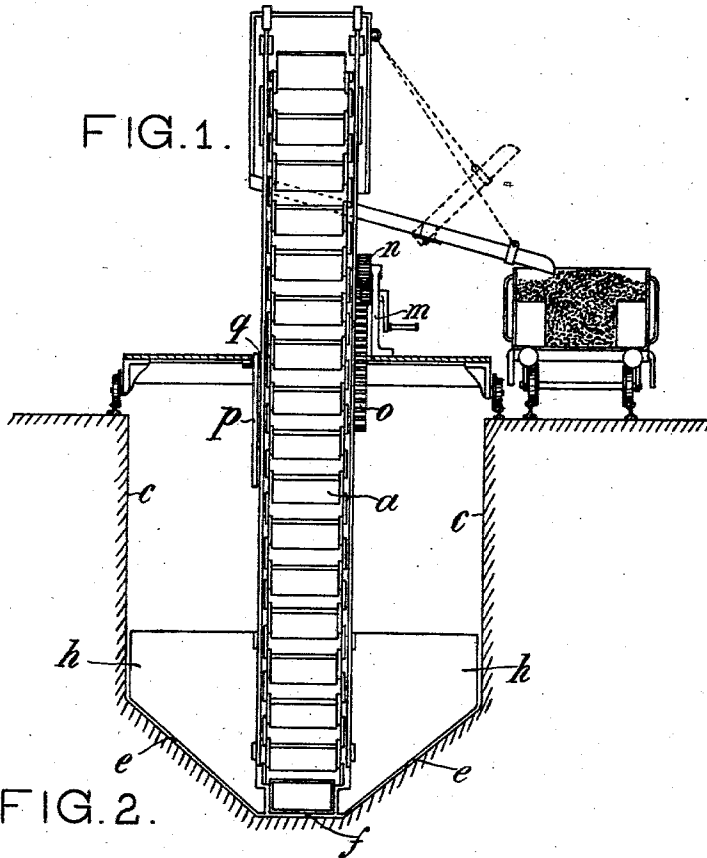
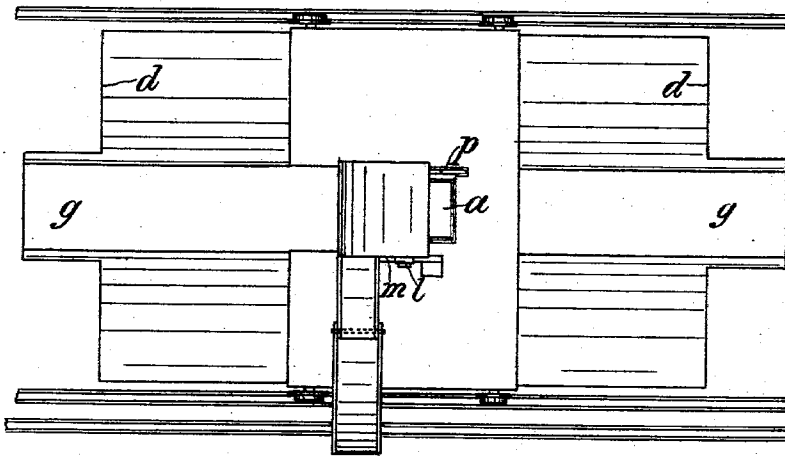

FIG. 2.



Witnesses:
George L. Schwenlant
Thomas Kilpatrick

Inventor
Carel Guenrad Vermeer
by H. van Oostrom
Attorney

C. C. VERMEER.

APPARATUS FOR STORING AND UNLOADING MATERIALS.

APPLICATION FILED JUNE 24, 1903.

NO MODEL.

2 SHEETS—SHEET 2.

FIG. 3.

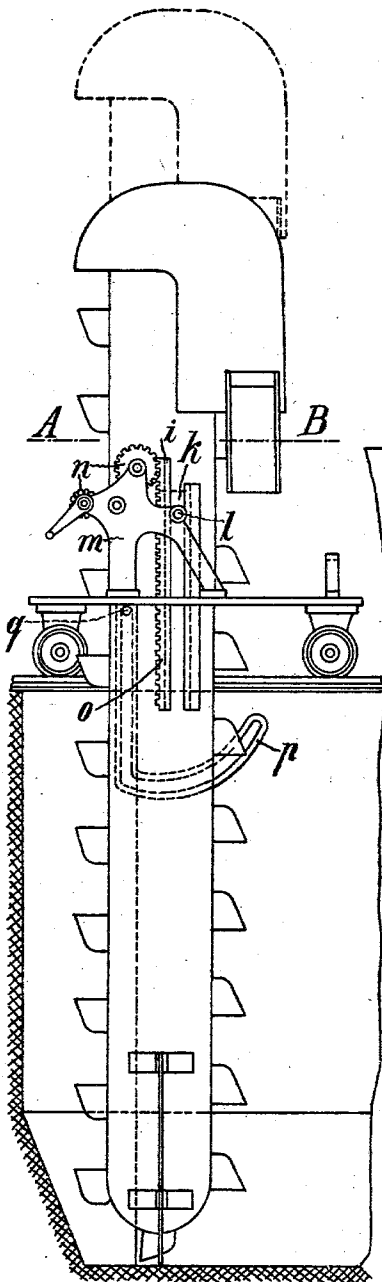

FIG. 5.

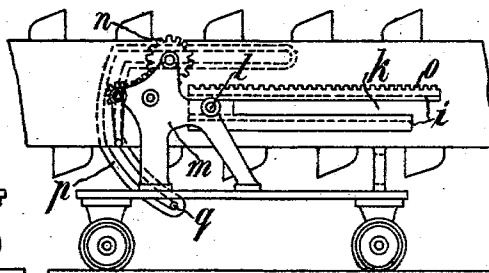
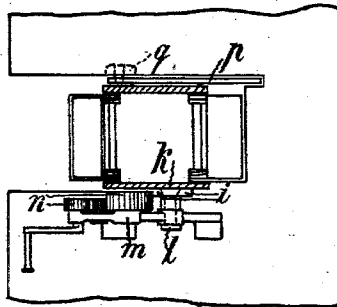

FIG. 4.

Witnesses:
 George G. Schoenlank
 Thomas Kuffner

Inventor
 Carel Cornelis Vermeer
 by Frank W. Deane,
 Attorney

UNITED STATES PATENT OFFICE.

CAREL C. VERMEER, OF BINNENHAVEN, O. Z., ROTTERDAM, NETHERLANDS.

APPARATUS FOR STORING AND UNLOADING MATERIALS.

SPECIFICATION forming part of Letters Patent No. 739,760, dated September 22, 1903.

Application filed June 24, 1903. Serial No. 162,936. (No model.)

To all whom it may concern:

Be it known that I, CAREL COENRAD VERMEER, a subject of the Queen of the Netherlands, residing at Binnenhaven, O. Z., Rotterdam, in the Kingdom of the Netherlands, have invented new and useful Improvements in and Relating to Apparatus for Storing and Unloading Materials, of which the following is a specification.

My invention relates to apparatus for storing and unloading materials, and has for its object to construct on land a pit designed for the reception of the materials and adapted for arranging a bucket elevator therein, this elevator extending from the bottom of the said pit to a certain height above the mouth of the same and being mounted on a truck, so that it can be raised and turned down upon this truck.

In the accompanying drawings I have shown a constructional form of my invention by way of example.

Figure 1 is a transverse section, and Fig. 2 a plan, of the pit with the bucket elevator arranged to be moved in the longitudinal direction of the pit. Figs. 3 and 4 are side elevations, and Fig. 5 is a sectional plan showing the bucket elevator.

The pit for storing the materials is of special form in transverse section, the lateral walls *c* of the same being joined by two sloping bottom parts *e* and a central horizontal part *f*, so as to constitute a channel into which the bucket elevator *a* dips, this elevator being mounted on a truck arranged to run at the top of the pit in the longitudinal direction of the same, Fig. 1. I provide in the transverse walls *d* of the pit recesses *g*, Fig. 2, into which the bucket elevator *a* is moved during the time the materials are introduced into the pit.

To the left and right hand sides of the bucket elevator *a* are secured, at the lower part of the same, partitions *h*, designed to prevent the material rolling behind the elevator in the unloading operation.

In the drawings illustrating a coal-pit for railways the pit is provided directly by the side of the track, so that the tender may pass under the discharge-channel of the bucket elevator, Fig. 1. For the purpose of not being obliged to delay refilling the pit until the bucket elevator has been moved back to its

original position, but to enable the pit to be filled again behind the elevator during its forward movement, it is expedient to so arrange the elevator upon its truck that it may be raised and turned down upon the same. On either side of the elevator is provided a guide *i* for a slide *k*, furnished with a trunnion *l*, which is fitted to turn in a bracket *m*, carried by the truck. A windlass having toothed wheels *n* in gear with a rack *o*, secured to the elevator, serves for raising this elevator to a height at which its point of gravity coincides with the axis of the trunnions *l*, thus facilitating the turning movement. For guiding the bucket elevator while it is being raised, for fixing the same in its operative position, and for limiting its downward movement I secure to the elevator a slotted guide *p*, with which a pin *q*, fixed to the truck, engages. At its lower end the slotted guide has an extension curved so as to allow the turning movement of the elevator about its trunnions *l*, the pin *q* on the truck entering the said extension on the elevator being turned down, Fig. 4. Owing to the possibility of raising the bucket elevator prior to being turned down, this elevator requires only to be moved back a little in order to be turned down and afterward to be placed upright for dipping behind the material in the pit. Thus the pit may be completely filled before the back movement of the elevator takes place, so that long stoppages will be avoided.

What I claim as my invention, and desire to secure by Letters Patent, is—

1. In apparatus of the character described, a pit having lateral sloping bottom parts joined by a central horizontal bottom part to form a channel, and recesses provided in its transverse walls, a truck arranged at the top of the pit and adapted to be moved in the longitudinal direction thereof, brackets carried by the truck, a bucket elevator fitted to turn about trunnions held in the brackets, this elevator extending to the bottom of the said channel, substantially as and for the purpose herein set forth.

2. In apparatus of the character described, a pit having lateral sloping bottom parts joined by a central horizontal bottom part to form a channel, and recesses provided in its transverse walls, a truck arranged at the top

of the pit and adapted to be moved in the longitudinal direction thereof, brackets carried by the truck, a bucket elevator fitted to turn about trunnions held in the brackets, 5 this elevator extending to the bottom of the said channel, and means for raising the elevator and turning the same about its trunnions, substantially as and for the purpose herein set forth.

10 3. In apparatus of the character described, a pit having lateral sloping bottom parts joined by a central horizontal bottom part to form a channel, and recesses provided in its transverse walls, a truck arranged at the top 15 of the pit and adapted to be moved in the longitudinal direction thereof, brackets carried by the truck, a bucket elevator fitted to turn about trunnions held in the brackets, this elevator extending to the bottom of the 20 said channel, and partitions attached to both sides of the elevator, substantially as and for the purpose herein set forth.

4. In apparatus of the character described, a pit having lateral sloping bottom parts

joined by a central horizontal bottom part to 25 form a channel, and recesses provided in its transverse walls, a truck arranged at the top of the pit, brackets, a bucket elevator fitted to turn about trunnions held in the brackets, 30 this elevator extending to the bottom of the said channel, partitions attached to both sides of the elevator, guides secured to the sides of the elevator, slides held in the said guides and provided with trunnions held in the 35 aforesaid brackets, a rack secured to the side of the elevator and means for actuating the same, a pin secured to the aforesaid truck, and a slotted guide furnished with a curved extension and secured to the elevator, sub- 40 stantially as and for the purpose herein set forth.

In testimony whereof I have signed my name to this specification in the presence of two subscribing witnesses.

C. C. VERMEER.

Witnesses:

S. LISTOE,

AIRE H. VOONWINDEN.