

Nov. 27, 1923.

1,475,552

J. A. PETERSON

MEANS FOR OPENING GRAIN DOORS OF CARS

Filed May 22, 1922

3 Sheets-Sheet 1

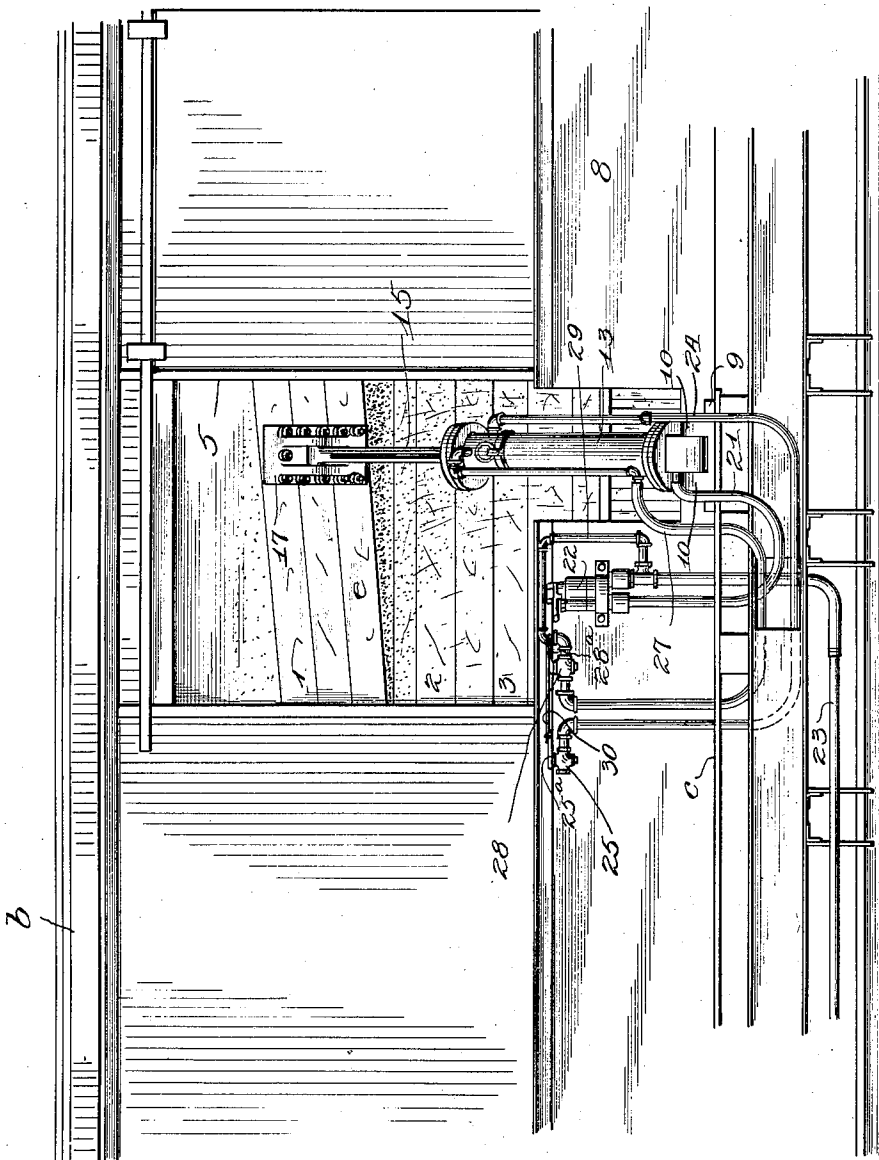

Fig. 1.

Inventor,  
*John A. Peterson*

By *Robert W. Watson*  
Attorney

Nov. 27, 1923.

1,475,552

J. A. PETERSON

MEANS FOR OPENING GRAIN DOORS OF CARS

Filed May 22, 1922

3 Sheets-Sheet 2

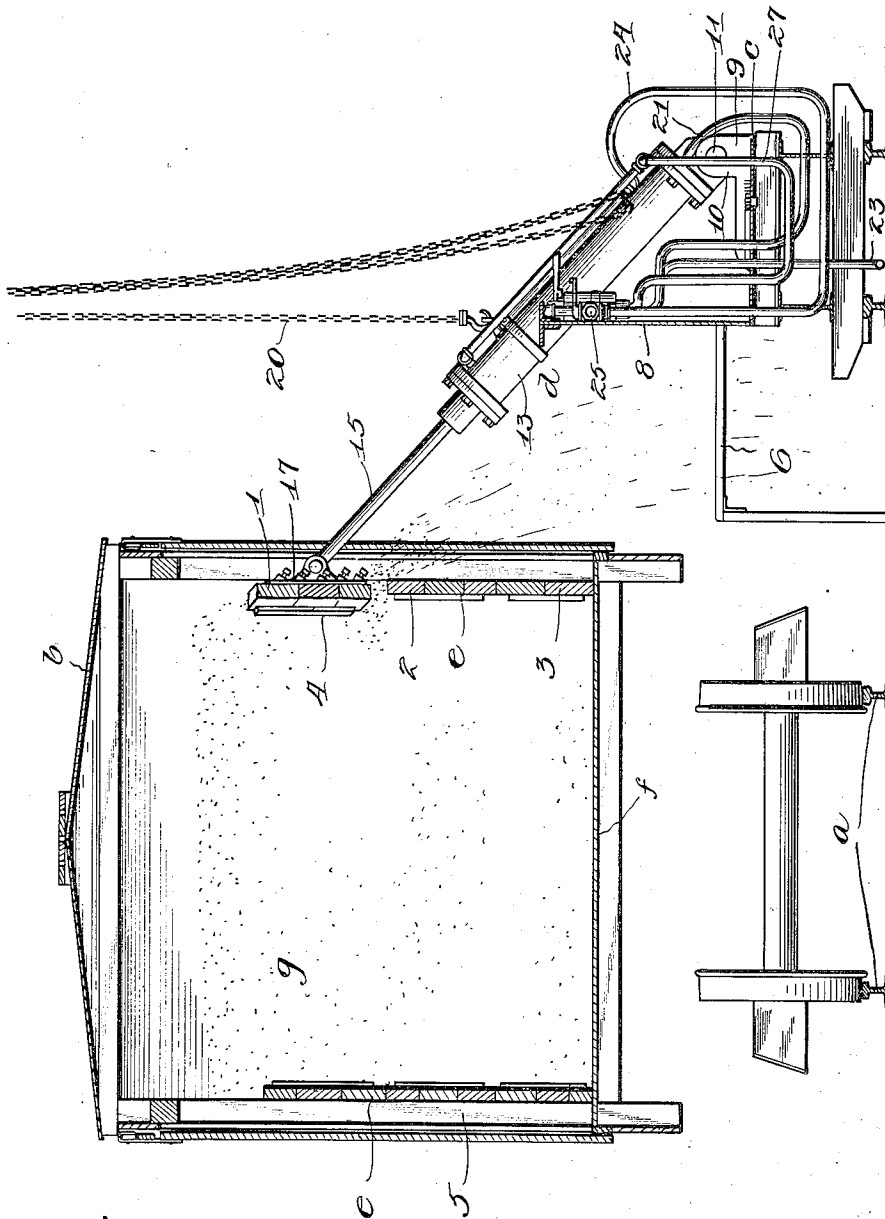

Fig. 2.

Inventor,  
John A. Peterson

By Robert Watson  
Attorney

Nov. 27, 1923.

1,475,552

J. A. PETERSON

MEANS FOR OPENING GRAIN DOORS OF CARS

Filed May 22, 1922

3 Sheets-Sheet 3

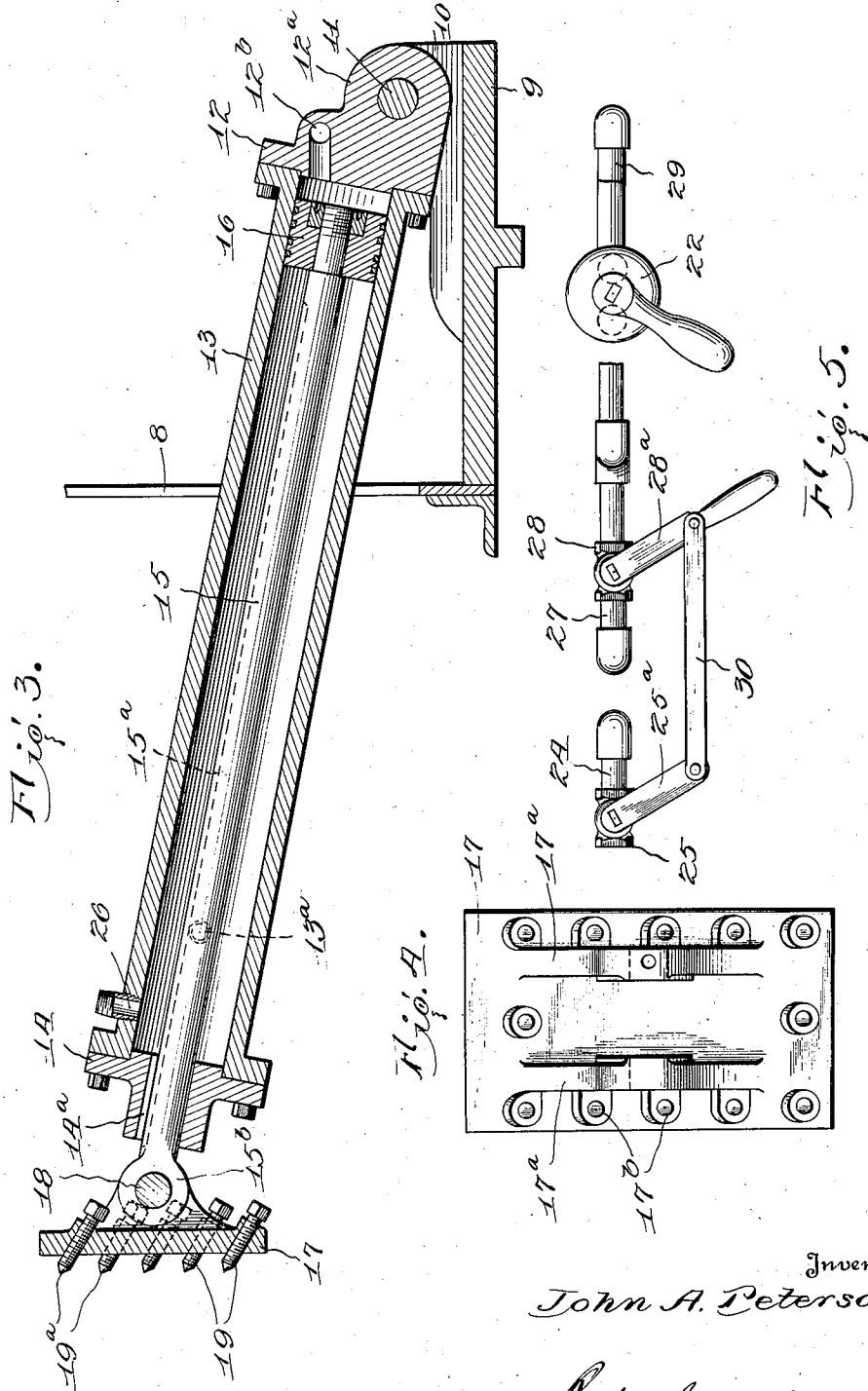

Inventor  
*John A. Peterson.*

By *Robert Watson*  
Attorney

# UNITED STATES PATENT OFFICE.

JOHN A. PETERSON, OF BALTIMORE, MARYLAND.

MEANS FOR OPENING GRAIN DOORS OF CARS.

Application filed May 22, 1922. Serial No. 562,717.

*To all whom it may concern:*

Be it known that I, JOHN A. PETERSON, a citizen of the United States, residing at Baltimore, in the State of Maryland, have invented certain new and useful Improvements in Means for Opening Grain Doors of Cars, of which the following is a specification.

This invention relates to means for opening the grain doors of railway cars. In loading box cars with grain, the doorways in the cars are boarded up with what are known as grain doors, consisting of boards or planks of substantial thickness, nailed to the inner sides of the door jambs and adapted to sustain the pressure of the grain. These doors are usually composed of several sections, for convenience in handling, each section consisting of several boards secured together by cross-pieces. Generally, a full car has three sections to a door.

When the loaded grain car arrives at its destination, in order to unload the car, it is customary to cut through the boards in the lowermost sections with axes to allow some of the grain to run out and relieve the pressure on the door, and to pry off the severed boards and those above them with steel bars. This is a laborious and time-consuming job, because the laborer has to cut into the faces of the boards with the axe, and the time consumed in opening the grain door is sometimes much greater than that required to unload the contents of the car after the door has been removed. Also, the work of cutting through the doors in one car after another is so fatiguing as to exhaust the men, particularly in warm weather. The mutilation of the boards, of course, occasions great waste of otherwise usable lumber.

In order to avoid these losses in time, energy and materials, I have provided means whereby grain doors may be opened by power in the space of a minute or two, these means comprising a rod or plunger having on one end a shoe adapted to engage the grain door, and means for moving the rod endwise in an inclined direction so as to force the grain door sections inwardly and upwardly. The force is applied near one end of each section and to the uppermost section first and then to the intermediate and lower sections, in succession. The inward and upward pressure applied to the top section causes the nails to be withdrawn from the door jamb and lifts the top section away

from the intermediate section, and the grain which was held back by the top section flows out through the opening formed between the sections. The intermediate section is then pressed inwardly and upwardly and when the grain which has held back by said section has poured out, the bottom section is pressed inwardly and raised from the car floor and the pressure back of said section is relieved. The pressure applied to one end of a section loosens the nails at the other end and the sections may then be readily removed to allow the grain to be shoveled out.

The rod or bar carrying the shoe which engages the grain door is mounted to swing in a vertical plane, so that the shoe may engage the several door sections in succession. In the drawing, the rod is arranged within an air cylinder which is pivoted to a support at one side of the track, and pipe connections are provided for admitting compressed air to and from the cylinder to operate the rod; but the invention is not limited to pneumatic means for operating the rod, as various well known mechanical devices may be provided for giving the necessary endwise thrust to the rod to cause the removal of the door sections.

In the accompanying drawing,

Fig. 1 is a side elevation of the central portion of a grain door and a rear elevation of the door-removing device, the upper section of the door being shown pressed inwardly and upwardly to permit the grain to flow out beneath it;

Fig. 2 is a central transverse section through the car, the door-removing device being shown in side elevation;

Fig. 3 is a central longitudinal section through the air cylinder, its support and the shoe;

Fig. 4 is a rear view of the shoe; and

Fig. 5 is a top plan view of the valves and adjacent portions of the air pipe.

Referring to the drawing, *a* represents the rails of a railway track, *b* represents a box car on the track, and *c* represents a fixed support at one side of the track upon which is mounted the door-removing device of my invention, the latter represented as a whole by *d*, in Fig. 2. The car is shown with grain doors *e*, consisting of sections 1, 2, and 3, each section composed of several boards connected by cross-pieces 4. These sections are arranged one upon the other and are nailed at their ends to the inner

sides of the door jambs or uprights 5. These grain doors are placed in the cars at the loading station to retain the grain indicated at *g*, and must be removed in order to remove the grain at the grain elevator to which the car is destined. When the grain is being unloaded the grain falls down through a grating which extends beneath and at the sides of the track and is received on suitable conveying apparatus which carries it to the elevators. Adjacent the track at the unloading point is a raised grated platform 6, through which the grain may fall and upon which the operator stands to cut open the grain doors when these are opened in the usual way by hand. Projecting above the platform is a sheet metal wall 8, the function of which is to prevent the grain from scattering beyond the grating. Upon the support *c* I secure a base 9, having upstanding spaced bearings 10 which receive a hinge pin 11, which pin extends through an opening in a hinge part 12<sup>a</sup>, projecting from a cylinder head 12 on one end of an air cylinder 13. The cylinder is thus hinged to a stationary base and is adapted to swing in a vertical plane at right angles to a car or the railway track. The other end of the cylinder is provided with a cap 14, and within the cylinder is arranged a rod or plunger 15, which extends through an opening in the head 14 and is provided with a piston 16, at its inner end. The plunger has a long keyway 15<sup>a</sup> and the head 14 is provided with a key 14<sup>a</sup>, which fits within the keyway and prevents the plunger from turning. Upon the end of the plunger is mounted a shoe 17, having parallel ribs 17<sup>a</sup> on its rear side, these ribs being provided with alined openings to receive a pivot pin 18 which extends through said openings and through an eye 15<sup>b</sup> on the plunger. The pivot pin extends horizontally through the openings in the shoe and plunger and the shoe may therefore rock vertically. The shoe shown in the drawing is composed of a plate having a plurality of threaded openings 17<sup>b</sup> extending through it at an angle of about 30° to the face of the plate, and in these openings are fitted screws 19 having pointed ends 19<sup>a</sup> for indenting the boards in the grain door when the shoe is forced against the boards. The support for the hinged end of the cylinder is lower than the car floor *f* and the free end of the cylinder is supported by a hoisting chain 20, by means of which the free end may be raised or lowered so that the shoe on the plunger may engage anyone of the grain door sections.

It will be seen from the relation of the parts that the pressure of the plunger will be applied to the several door sections in an inward and upward direction. In order to force the plunger outwardly, I provide a

pipe 21 which is connected at one end to a port 12<sup>b</sup> in the cylinder head 12, and the other end of said pipe is connected to an engineer's valve 22, through which compressed air from a supply pipe 23 may be admitted to the cylinder, in one position of the valve, and exhausted from the cylinder in another position of the valve. In order to prevent damage to the parts, should the operator fail to cut off the air pressure after the plunger has released a door section, and also to permit the air in advance of the piston to escape, I provide a port 13<sup>a</sup> in the cylinder, spaced from the head 14 a sufficient distance to allow the piston to pass the port. This port is normally in communication with the atmosphere through a pipe 24 and a normally open relief valve 25. Thus, when the plunger is forced outwardly by the admission of air through the valve 22, should the operator fail to close said valve, the air in the cylinder will escape through the pipe 24 as soon as the piston 16 passes the port 13<sup>a</sup>, and the pressure behind the piston will be so reduced that no harm can be done to the apparatus. For the purpose of returning the plunger to its inner position, I provide a port 26, in the outer end of the cylinder, adjacent the head 14, through which compressed air may be admitted by means of a pipe 27, connected to said port and through a normally closed valve 28 and pipe 29 to the supply pipe 23. The levers 25<sup>a</sup> and 28<sup>a</sup> of the valves 25 and 28 are connected by a link 30, so as to move together. Thus, the valve 25 is open and the valve 28 is closed while the plunger is being driven outwardly by pressure admitted to the back of the piston through the valve 22, and the air in advance of the piston escapes through the valve 25; or if the piston goes beyond the port 13<sup>a</sup> before the pressure is cut off at the valve 22, the air at the back of the piston will escape through the port 13<sup>a</sup> and the valve 25. After the plunger has been driven outwardly it is necessary to apply air pressure to the forward side of the piston to return the plunger. To accomplish this, the valve 28 is opened and by the same movement the valve 25 is closed. Air then flows from the supply pipe 23 through valve 28 and pipe 27 to the forward end of the cylinder and forces the piston inward. The valve 25 being closed, no air can escape through the port 13<sup>a</sup>, but the air at the inner end of the cylinder will escape through the pipe 21 and the engineer's valve 22.

In operation, the car carrying the grain is located so that the shoe on the plunger will engage the grain door sections near one side of the door. The operator then, by means of the hoisting chains, arranges the cylinder at such an angle that the shoe on the plunger will engage the uppermost section of the door, and by admitting air gradually the

plunger is forced outwardly until the shoe on the plunger is in engagement with or close to said upper section. Further air pressure is then admitted to the cylinder and this causes the plunger to press the uppermost door section inwardly far enough to withdraw the nails from the door jamb adjacent the shoe and also to raise this door section from the intermediate section so that the grain will flow out between the two sections and relieve the pressure back of the uppermost section. The operator then admits air to the free end of the cylinder to return the plunger to its inner position and the cylinder is then lowered, by means of the chain, until the shoe on the plunger is in position to engage the intermediate section of the door and air is then admitted to the valve 22 to force the plunger outwardly and apply pressure to the intermediate section. This pressure forces one end of the intermediate section inwardly and upwardly and the grain then flows out in a gap formed between the intermediate and lower sections. In the same way, the lower section is then pressed inwardly and upwardly and a gap is formed between said section and floor through which the grain pours out. The pressure applied to the several sections forces out the nails at one end of each section and loosens or forces out the nails at the other end so that the sections can be readily removed by hand and the grain can then be shoveled out of the car in the usual way.

In operating the plunger to loosen the door sections, the valve 22 is used for admitting air to the cylinder to force the plunger outwardly, and also to release the air back of the piston when the plunger is to be returned. Should the operator fail to cut off the pressure back of the piston after the plunger has moved far enough to release a door section, the piston will pass the port 13<sup>a</sup> in the cylinder and the compressed air back of the piston will escape through the said port and the valve 25. To return the piston from its outer position, air is admitted through the valve 23 and as this valve is opened to admit the air to the forward end of the cylinder, the valve 25 is simultaneously closed by reason of the connections between said valves so that the air admitted to drive the piston back will not escape through the port 13<sup>a</sup>, which is controlled by the valve 25.

By means of the invention described, the grain door of a car can be opened in a minute or two. It will be understood that at grain elevators where large numbers of grain cars are unloaded, a plurality of these door-opening devices will be used and located at various unloading points.

What I claim is:

1. The combination with a railway track,

of means for opening the grain doors of cars on the track comprising a support at one side of the track and power-operated means on said support adapted to apply an upwardly and inwardly inclined thrust to the upper part of a grain door of a car on the track and means for adjusting said power-operated means so as to apply similar thrusts to intermediate and lower parts of the door in succession.

2. The combination with a railway track, of means for opening the grain doors of cars on the track comprising a support at one side of the track and power-operated means, pivoted on said support below the level of a grain car floor, adapted to give an upward and inward thrust to the doors of cars on the track.

3. The combination with a railway track, of means for opening the grain doors of cars on the track comprising a support at one side of the track, a bar pivotally mounted on said support above the track and adapted to extend in an upwardly inclined direction from its pivotal point to different vertical parts of the grain door of a car on the track, means on the upper end of said bar for engaging a grain door, and means for forcing said bar endwise toward the door.

4. The combination with a railway track, of means for opening the grain doors of cars on the track comprising a support at one side of the track, a bar pivotally mounted on said support above the track and below the level of a grain car floor and adapted to extend in an upwardly inclined direction from its pivotal point to different vertical parts of the grain door of a car on the track, means on the upper end of said bar for engaging a grain door, and means for forcing said bar endwise toward the door.

5. The combination with a railway track, of means for opening the grain doors of cars on the track comprising a support at one side of the track, a member pivotally carried on said support and adapted to extend in an upwardly inclined direction from the support toward the grain door of a car on the track, said member having means at its upper end for engaging a grain door, means for holding the member in different upwardly inclined positions, directed toward different vertical parts of the grain door, and power-operated means for forcing the member toward the door.

6. The combination with a railway track, of means for opening the grain doors of cars on the track comprising a support at one side of the track, a member pivotally carried on said support below the level of a grain car floor and adapted to extend in an upwardly inclined direction from the support toward the grain door of a car on

the track, said member having means at its upper end for engaging a grain door, means for holding the member in different upwardly inclined positions, directed toward  
 5 different vertical parts of the grain door, and power-operated means for forcing the member toward the door.

7. The combination with a railway track, of means for forcing open grain doors of  
 10 cars on the track comprising a support at one side of the track, a cylinder pivoted to said support and adapted to extend in an upwardly inclined direction from the support toward the grain door of a car on the  
 15 track, a plunger rod projecting through the upper end of the cylinder, means on said rod for engaging a grain door, and means for admitting fluid pressure to said cylinder to operate the rod.

8. The combination with a railway track, of means for forcing open grain doors of  
 20 cars on the track comprising a support at one side of the track, a cylinder pivoted to said support and adapted to extend in an upwardly inclined direction from the support toward the grain door of a car on the track,  
 25 a plunger rod projecting through the upper end of the cylinder, means on said rod for engaging a grain door, means for directing said cylinder and rod toward different  
 30 vertical parts of the grain door, and means for admitting fluid pressure to said cylinder to operate the rod.

9. The combination with a railway track, of means for forcing open grain doors of  
 35 cars on the track comprising a support at one side of the track, a cylinder pivoted to said support at a point below the level of a grain car floor and adapted to extend in an upwardly inclined direction from the  
 40 support toward the grain door of a car on the track, a plunger rod projecting through the upper end of the cylinder, means on said rod for engaging a grain door, and means  
 45 for admitting fluid pressure to said cylinder to operate the rod.

10. The combination with a railway track, of means for forcing open grain doors of  
 50 cars on said track comprising a cylinder pivotally supported at one side of the track and adapted to extend in an upwardly in-

clined direction from the support toward the grain door of a car on the track, a plunger rod in said cylinder and projecting  
 55 through the upper end thereof, a shoe pivoted to said rod and adapted to engage the grain doors, and means for forcing said rod outwardly.

11. The combination with a railway track, of means for forcing open grain doors of  
 60 cars on said track comprising a cylinder pivotally supported at one side of the track and adapted to extend in an upwardly inclined direction from the support toward the grain door of a car on the track, a plunger  
 65 rod in said cylinder and projecting through the upper end thereof, a shoe pivoted to said rod and having a plurality of pointed projections adapted to engage the grain doors, and means for forcing said  
 70 rod outwardly.

12. The combination with a railway track, of a cylinder pivoted at one side of the track and adapted to swing in a plane transversely  
 75 of the track, a plunger rod having a piston within the cylinder and having means at its outer end for engaging a grain door, a valve for admitting fluid under pressure to the cylinder to drive the plunger outwardly,  
 80 and a port in the cylinder for permitting the fluid to escape after the piston has passed said port.

13. The combination with a railway track, of a cylinder pivoted at one side of the track and adapted to swing in a plane trans-  
 85 versely of the track, a plunger rod having a piston within the cylinder and having means at its outer end for engaging a grain door, a valve for admitting fluid under pressure to the cylinder to drive the plunger outwardly,  
 90 a port in the cylinder for permitting the fluid to escape after the piston has passed said port, a valve controlling said port, a valve for admitting fluid under pressure to the outer end of the cylinder to drive the  
 95 plunger inwardly, and connections between the latter valves for causing one to open when the other closes, and vice versa.

In testimony whereof I affix my signature.

JOHN A. PETERSON.