

(No Model.)

A. HAND.
BILLIARD TABLE.

No. 605,872.

Patented June 21, 1898.

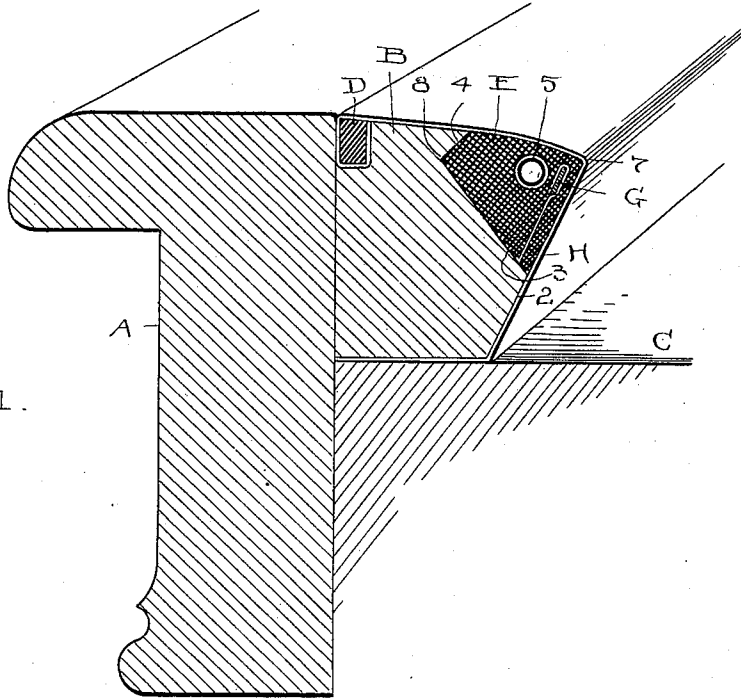

FIG. 1.

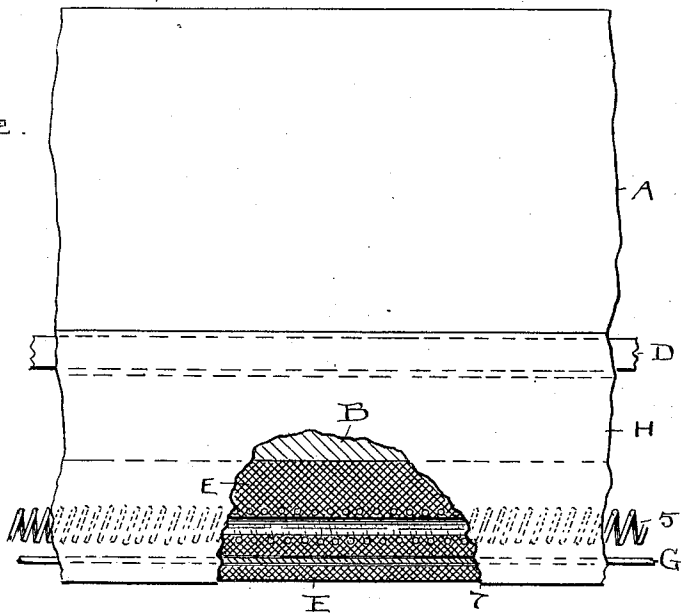

FIG. 2.

ATTEST
J. B. Moore
H. L. Moore.

INVENTOR
August Hand

BY *H. J. Fisher* ATTORNEY

UNITED STATES PATENT OFFICE.

AUGUST HAND, OF CLEVELAND, OHIO.

BILLIARD-TABLE.

SPECIFICATION forming part of Letters Patent No. 605,872, dated June 21, 1898.

Application filed June 22, 1897. Serial No. 641,796. (No model.)

To all whom it may concern:

Be it known that I, AUGUST HAND, a citizen of the United States, residing at Cleveland, in the county of Cuyahoga and State of Ohio, have invented certain new and useful Improvements in Billiard-Tables; and I do declare that the following is a full, clear, and exact description of the invention, which will enable others skilled in the art to which it appertains to make and use the same.

My invention relates to improvements in billiard-tables; and the invention consists more particularly in the construction of the cushion about the top of the table, all substantially as shown and described, and particularly pointed out in the claims.

In the accompanying drawings, Figure 1 is a perspective elevation of a cross-section of a billiard-table border and the cushion thereon constructed according to my invention; and Fig. 2 is a plan view thereof with a portion of the rubber cushion broken away to disclose the wire spring embedded in the rubber strip in front thereof, substantially as shown and described.

Referring now to Fig. 1, A represents the usual border-piece or rail, which may be of any of the common constructions and forms part of the framework of the table.

B is the cushion-strip, which rests against the border-piece A and is flush therewith at its top, while at its bottom it rests on the table proper, C. The strip B is rabbeted along its outer top edge to receive the cloth strip or holder D, and at its front is constructed with an inclined face 2, so as to recede sufficiently at the bottom to give the requisite projection to the cushion at the top, as is usual now in billiard-tables generally. The special point of novelty in this strip is found in the peculiarly-constructed recess longitudinally along the front and top thereof. This recess or rabbet has a lower inclined surface 3 and an upper inclined surface 4 at substantially right angles to surface 3 and forming an overhanging shoulder retreating toward its bottom and terminating in an angle which lies almost directly behind the point of impact or stroke by the ball. The rubber cushion E is secured in this rabbet and occupies the same, so as to be flush on top and along the front

with strip B and fill out the recess fully and evenly at all points.

Now in order that the cushion may have the desired resiliency to give the balls the quick and certain rebound which a cushion should always impart, I first of all obtain a coil-of-wire spring of suitable size and quality and imbed the same in the rubber by molding the rubber about the spring in the position relatively about as shown, so that the spring will be behind the point of impact or blow from the ball. Usually I make a spring with a very close coil and stretch it to about the space or distance shown before casting the rubber thereon, and the bore of the spring is kept open all the way, as seen in cross-section, Fig. 1. The exact point of impact is the somewhat sharp edge 7 of the strip B, and the spring 5 lies directly in line between point 7 and the point 8 of the recess in the angles of the converging sides 3 and 4. This effectually overcomes any tendency that might occur in the rubber to spring or bulge upward under the blows of the balls, and the inclined wall 4 above especially overcomes any such tendency as well as enabling me to utilize the fullest depth of the rubber cushion to cushion the blow.

It is now deemed to be the first essential of a perfect cushion to have a rebound as nearly equal to the original blow upon the ball as possible, the effect being something like a back stroke by a cue, and a thoroughly good cushion will not allow any dead balls at all along its sides however slowly they approach if they come with energy enough to receive reaction from the cushion. The present construction possesses these essentials of a good cushion in a marked degree, and the rapid rebound of the ball under the impetus of the combined spring actions of the cushion is most noticeable.

G represents a spring metallic strip with a cloth sheath and embedded in the rubber midway between the spring 5 and the face of the cushion and is designed to form a backing for the rubber at the point of stroke, so as to receive the stroke to itself largely and prevent the ball from more or less embedding itself in the rubber, as would occur if some such precaution were not taken. As it

is, there is just rubber enough in front of strip G to initially cushion the ball, while all the balance of the cushion, or all that is behind it, is absorbed through said strip. This
 5 also helps materially to preserve the integrity of the rubber in front of the strip and prevents any breaking down or unevenness in the edge 7 of the rubber, as might occur if such backing were not provided.

10 H represents the usual cloth cover, which partly envelops the cushion-strip.

What I claim as new, and desire to secure by Letters Patent, is—

1. A cushion for billiard-tables consisting
 15 of a strip of india-rubber having a bore longitudinally through the same from end to end, a coiled-wire spring vulcanized in said rubber about said bore and a flat canvas-covered strip of spring metal vulcanized in the rubber in
 20 front of said coiled wire, said flat strip and

coiled wire being located directly behind the portion of the cushion which receives the stroke of the ball and having a wall of rubber between them, substantially as described.

2. In a billiard-table, a cushion-strip B 25 with a longitudinal rabbet having inclined converging sides 3 and 4 terminating in a point 8 directly at the rear of the line of stroke by the ball, in combination with a rubber cushion fixed in said rabbet and having 30 a longitudinal bore in the stroke-line with said point 8, a coiled spring in the wall of said bore and a flat metal spring in front of said coiled spring, substantially as described.

Witness my hand to the foregoing specification this 7th day of June, 1897. 35

AUGUST HAND.

Witnesses:

H. T. FISHER,
 H. E. MUDRA.