

March 28, 1950

A. W. SAWITZKE

2,501,970

NEWSPAPER VENDING MACHINE

Filed Jan. 16, 1946

3 Sheets-Sheet 1

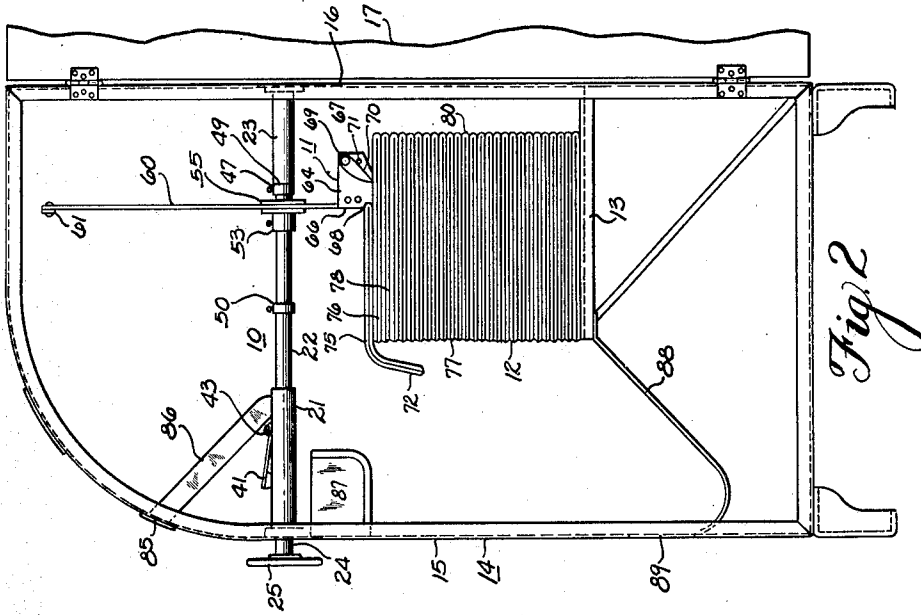

Fig. 2

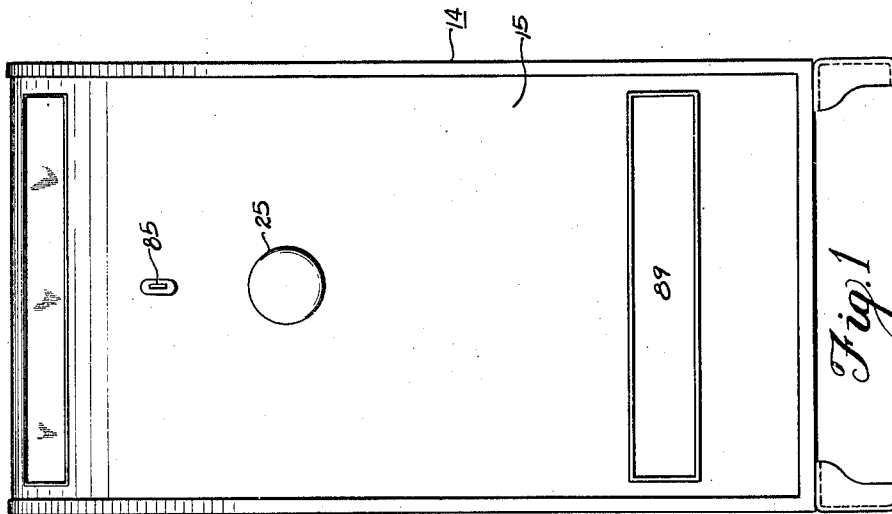

Fig. 1

INVENTOR.
Arthur W. Sawitzke
BY
Shoading and Krost
attys

March 28, 1950

A. W. SAWITZKE
NEWSPAPER VENDING MACHINE

2,501,970

Filed Jan. 16, 1946

3 Sheets-Sheet 2

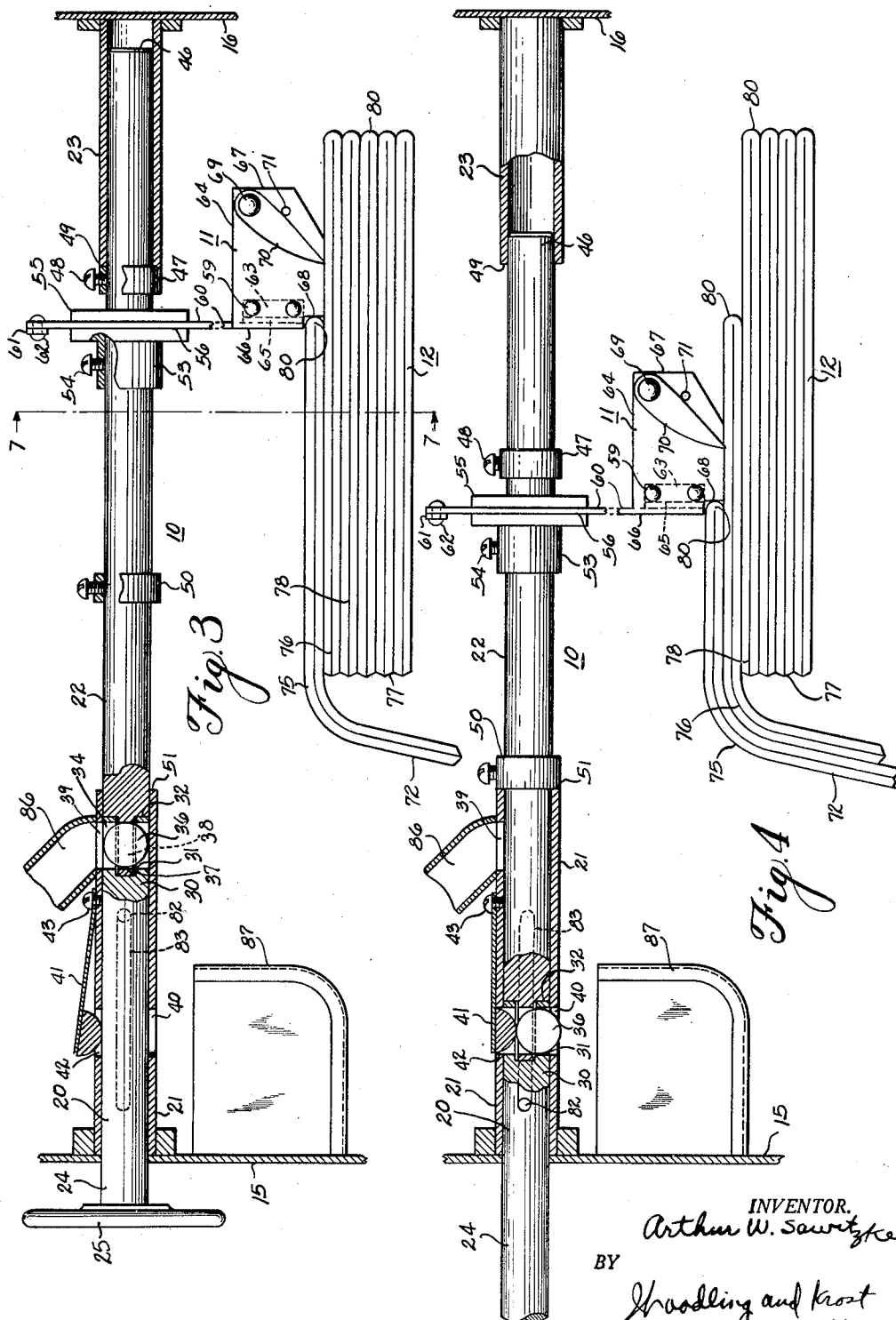

INVENTOR,
Arthur W. Sawitzke
BY
Shoading and Krost
attys

March 28, 1950

A. W. SAWITZKE
NEWSPAPER VENDING MACHINE

2,501,970

Filed Jan. 16, 1946

3 Sheets-Sheet 3

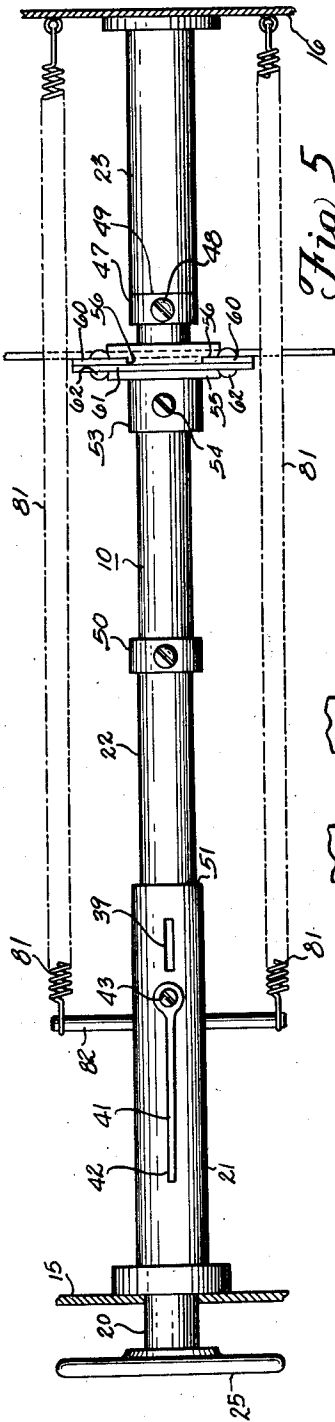

Fig. 5

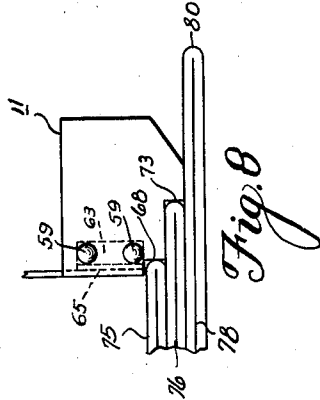

Fig. 8

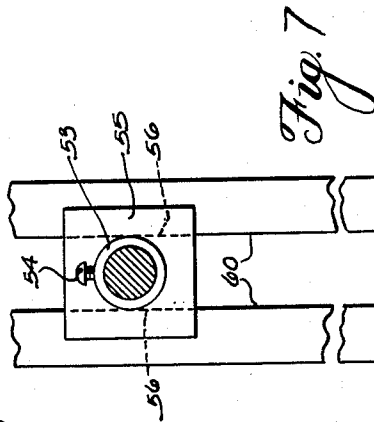

Fig. 7

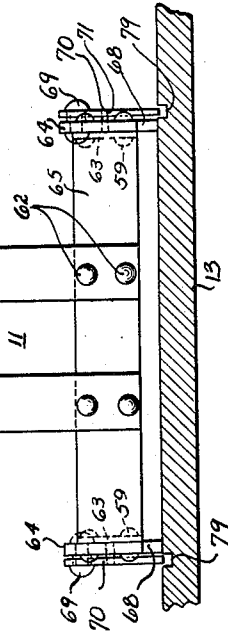

Fig. 6

INVENTOR.
Arthur W. Sawitzke
BY
Shoading and Kost
attys

UNITED STATES PATENT OFFICE

2,501,970

NEWSPAPER VENDING MACHINE

Arthur W. Sawitzke, Cleveland, Ohio, assignor of
one-half to Glenn H. Garden

Application January 16, 1946, Serial No. 641,502

2 Claims. (Cl. 312—55)

1

My invention relates in general to improvements in vending machines and in particular to improvements in a newspaper vending machine. My vending machine may be used for vending newspapers, magazines and other articles, hereinafter referred to as newspapers in my specification and claims.

An object of my invention is the provision of a vending machine for delivering newspapers one by one from a stack of newspapers.

Another object of my invention is the provision of a vending machine which is manually operable to deliver a newspaper to a customer only when a coin is placed in the coin controlled mechanism of the vending machine.

Another object of my invention is the provision of a vending machine which has for its operation the steps of moving the top newspaper of a stack of newspapers a distance of less than $\frac{1}{2}$ one of its dimensions from the stack and then moving the top newspaper a distance to extend it more than $\frac{1}{2}$ said dimension from the stack and simultaneously moving the next adjacent top newspaper a distance less than $\frac{1}{2}$ said dimension from the stack, whereby the top newspaper is vended to a customer.

Another object of my invention is the provision of an ejector reciprocally mounted within the newspaper vending machine and disposed to engage a newspaper of a stack of newspapers and move that paper partially from the stack.

Another object of my invention is the provision of a newspaper vending machine having an ejector therein which rests by its own weight upon the stack of newspapers and follows downwardly therethrough as the newspapers are vended one by one from the top of the stack.

A further object of my invention is the provision of a newspaper vending machine having an ejector reciprocally mounted therein with a coin controlled manually operable slide means for reciprocally moving the ejector to vend newspapers one by one from the stack of newspapers.

A still further object of my invention is the provision of a coin controlled mechanism which has a pair of reciprocally movable slide members disposed to be operatively connected by a coin, whereby one member may move the other member.

Other objects and a fuller understanding of the invention may be had by referring to the following description and claims, taken in conjunction with the accompanying drawing, in which:

Figure 1 of my drawing is a front-elevational

2

view of the preferred embodiment of my newspaper vending machine;

Figure 2 is a side view of my invention with the door swung open to illustrate the manually operable parts therein;

Figure 3 is an enlarged fragmentary view, certain parts being shown in cross-section, of my coin controlled mechanism in a first position;

Figure 4 is an enlarged fragmentary view of my coin controlled mechanism in a second position, certain parts being shown in cross-section;

Figure 5 is a top view of my coin controlled mechanism;

Figure 6 is an enlarged oblique view of the male and female portions of my coin controlled mechanism;

Figure 7 is a cross-sectional view taken along the line 7—7 of Figure 3; and

Figure 8 is a modification of my invention.

My newspaper vending machine comprises in general a coin controlled mechanism 10, which is manually operable to reciprocally move a newspaper ejector 11. The newspaper ejector 11 rests substantially by its own weight upon the newspapers in the stack 12, which is supported by a shelf 13. The working parts of my newspaper vending machine are enclosed within a housing 14 which has a front side 15 and a back side 16. In Figure 2 of my drawing I have shown the door 17, on one end of the vending machine, as being opened to fully illustrate my invention.

My coin controlled mechanism 10 has a pull member 20 and a slide member 22. The pull member 20 is reciprocally movable supported by a front sleeve 21, which may be fastened by welding or other suitable means to the front side 15 of the housing 14. The pull member 20 extends outwardly through the front side 15. The external portion 24 of the pull member 20 is terminated in a handle knob 25. The slide member 22 is reciprocally movable mounted in a back sleeve 23, which may be welded or fastened by other suitable means to the back side 16 of the housing 14. In my drawings, I have illustrated the pull member 20 and the slide member 22 as being cylindrical rods of substantially the same diameters. It is to be understood however, that rods of other shapes may be used without departing from the scope of my invention.

The slide member 22 extends into the front sleeve 21 to engage the end of the pull member 20. This end of the pull member 20 which the slide member 22 engages is the female end portion 30. As is best illustrated in Figure 6, the

3

female end portion 30 has a groove 31 therein. The groove 31 extends diametrically of the pull member and longitudinally from the end 32. The diametrically opposite side pieces 33 of this female end portion 30, which define the groove 31 have an opening 34 therein. The dimensions of this opening 34 are dependent upon the size of the coin to be used to control the mechanism. The length of the opening 34 is slightly greater than the diameter of the coin. The width of the opening 34 is slightly greater than the thickness of the coin.

The slide member 22 has a male end portion 37 adapted to enter the groove 31 of the female end portion 30 of the pull member 20. This male end portion 37 has an opening 38 therethrough disposed for alignment with the openings 34 in the female end portion 30. The opening 38 is substantially the same size as the openings 34. The front sleeve 21, which supports these members 20 and 22 in operative relationship, has an opening 39 in the top thereof. When the slide member 22 is in a first position, as illustrated in Figure 3, the openings 34 and 38 are aligned with the opening 39. The coin 36 may thus be inserted in the openings in the male and female end portions to connect the slide member 22 to the pull member 20. The front sleeve has an opening 40, of substantially the same size as the opening 34, in the bottom side thereof, through which the coin 36 is removed. This opening 40 is disposed for alignment with the openings 34 and 38 of the male and female end portions 30 and 37 when the slide member is in a second position, as illustrated in Figure 4. The front sleeve 21 also has an opening 42 located diametrically opposite the opening 40. A spring member 41 extends through the opening 42 in the front sleeve 21 to force the coin 36 through the opening 40 and from the coin controlled mechanism 10. This spring member 41 may be fastened to the front sleeve 21 by screw 43, as illustrated in my drawing or by other suitable means.

The back sleeve member 23 extends inwardly from the back side 16 a sufficient distance to permit the endwise movement of the slide member 22 from the first position, as shown in Figure 3, to the second position as shown in Figure 4 without the tail end 46 of the slide member 22 leaving the back sleeve 23. It is thus seen that at all times the back sleeve 23 supports this tail end 46 of the slide member 22. A back stop collar 47 fastened by a set screw 48 or other suitable means to the slide member 22 hits the end 49 of the back sleeve 23. This back stop collar 47 is fastened to the slide member 22 to stop endwise motion in a second direction towards the back side of the housing. When the back stop collar 47 is against the end 49 of the back sleeve 23 the slide member 22 is in the first position as illustrated in Figure 3. Similarly a front stop collar 50 may be used to prevent endwise movement of the slide member 22 in a first direction toward the front side 15 of the housing 14. When the front stop collar 50 engages the end 51 of the front sleeve 21 the slide member 22 is in the second position, as best illustrated in Figure 4. The slide member 22 moves less than $\frac{1}{2}$ the width of the newspaper when moving from the first position to the second position.

A flange support 53, for supporting the newspaper ejector 11, is positioned between the front stop collar 50 and the back stop collar 47 on the slide member 22. This flange support 53 may be fastened adjustably to the slide member 22 by

4

means of a set screw 54 or other suitable means. As is best illustrated in Figure 7, the flange has a substantially rectangular flange portion 55 with grooves 56 therein. These grooves 56 are located on opposite edges of the rectangular flange portion 55 and are disposed to permit vertical movement of the newspaper ejector 11 toward and away from the stack of newspapers. This newspaper ejector 11 is operatively fastened to the slide member 22 by runners 60 which reciprocally slide within the grooves 56 to permit the ejector 11 to rest by its own weight on the stack of newspapers. The runners 60 are placed on diametrically opposite sides of the slide member 22 to stabilize vertical movement of the newspaper ejector 11. The ends of the runners furthest from the newspaper ejector 11 may be fastened together by a cross member 61. This cross member 61 may be fastened by rivets 62 or other suitable means to the individual runners 60, and spaces the runners at that end the same distance apart as they are at the newspaper ejector 11. Although I have described my preferred method of fastening the ejector 11 to the slide member 22, it is understood that other suitable means may be used which will permit vertical movement of the ejector with respect to the slide member 22, and at the same time will permit reciprocal horizontal movement of the newspaper ejector 11 in the first and second direction by the endwise movement of the slide member 22.

The newspaper ejector 11 has a pair of runner plates 64 which ride on the top of the stack of newspapers. The runner plates 64 may be fastened to the runner 60 by a spacer member 65 which extends between the runner plates 64. The spacer member 65 may be fastened by suitable means such, for example, as rivets 62 to the runners 60. This spacer member 65 has end flanges 63 disposed to be fastened to the runner plates 64. These end flanges 63 position the runner plates 64 parallel to each other and to the direction of reciprocal movement of the slide member 22. The runner plates 64 and the end flanges 63 of the spacer member 65 may be fastened by rivets 59, or by other suitable means, such for example bolts, thus forming the parts into a unit. For purposes of clarity I have designated these runner plates 64 as having a front edge 66 which faces the front side 15 of the housing 14 and a back edge 67 which faces the back side 16 of the housing 14. A pointed finger 70, pivotably fastened near the top of the runner plate 64 and substantially on the back edge 67 thereof by rivets 69 or other suitable means, digs into the top newspaper of the stack. When the ejector is moved in the first direction toward the front side 15 it moves the engaged top newspaper a distance less than $\frac{1}{2}$ its width from the stack. This pointed finger 70 slides over the top newspaper when the newspaper ejector 11 is moved in the second direction toward the back side 16 of the housing 14. A stop pin 71 which is fastened to the runner plate 64, may be employed to prevent excess rotation of the pointed finger whereby the newspaper engaged will be moved in the first direction toward the front side of the housing when the newspaper ejector is moved in that direction.

At the beginning of the cycle of operation of my newspaper vending machine a stack of newspapers 12 is supported on the shelf 13 as shown in Figure 2. This stack of newspapers includes a top newspaper 75 and a next adjacent newspaper 76. The top newspaper 75 is positioned

5

with the forward edge 72 of the top newspaper 75 overhanging the front side 77 of the stack. The front side 77 of the stack is the side nearest the front side 15 of the housing 14. The newspaper ejector 11 rests substantially by its own weight on the next adjacent newspaper 76, and in the first position nearest the back side of the housing. A notch 68 in the front edge 66 of the newspaper ejector 11 permits a portion of the ejector to extend over the top newspaper 75 to prevent the back side 80 of the top newspaper from tipping up and away from the stack. The pointed finger 79 engages the next adjacent newspaper 76. The slide member 22 is held in the first position, nearest the back side of the housing by springs 81 which are fastened between the pull member 20 and the back side 16 of the housing 14. A rod 82 extending through suitable slots 83 in the front sleeve 21 and fastened to the pull member 20 may be used to operatively fasten the springs 81 thereto. The slots 83 in the sleeve permit the rod 82 to travel longitudinally of the sleeve as the pull member 20 is traveling endwise within the sleeve.

The operator, in operating the machine, drops a coin in a coin slot 85, located above the handle knob 25 on the front side 15 of the housing 14. A coin chute 86, which may be constructed of any suitable design and material conducts this coin into the openings 34 and 38 of the male and female portions of the pull member 20 of the slide member 22. It is understood that at this time the slide member is in the first position. The coin operatively connects the slide member 22 to the pull member 20. The operator pulls the handle knob 25 away from the front side of the machine, thus causing the pull member 20 to move the slide member 22 endwise in the first direction toward the front side of the housing, and from the first position as shown in Figure 3. In traveling in this first direction, the slide member moves the newspaper ejector therewith. The pointed fingers engage the next adjacent newspaper 76, and the notched portion 66 engages the top newspaper 75 to move these newspapers forward in the first direction a distance less than $\frac{1}{2}$ their width. When the front stop collar 50 hits the end 51 of the front sleeve 21, the endwise movement of the slide member 22, and thus the forward movement of the ejector 11 in the first direction, is stopped. Figure 4 best illustrates the relationship between the working parts of my vending machine at this second position.

The top newspaper 75 now extends more than $\frac{1}{2}$ its width from the stack, and the next adjacent newspaper extends less than $\frac{1}{2}$ its width from the stack. The top newspaper 75, extending more than one-half its width from the stack of newspapers bends the next adjacent newspaper 76 and falls from the top of the stack on the front side 77 thereof. At this same time the coin spring remover member 41 forces the coin 36 from the openings 34 and 38 in the male and female portions and through the opening 40 in the bottom of the front sleeve 21. The coin after leaving the front sleeve 21 falls into a suitable coin catch pan 87 which may be fastened by suitable means to the front side 15 of the housing 14. This coin catch pan may be of any suitable design and construction which will hold a plurality of coins. The newspaper 75 falls into a newspaper chute 88 which carries it to a mouth 89 in the front side 15 of the newspaper vending machine. The mouth 89 is an opening

6

located in the front side 15 and below the handle knob 15 through which the operator receives his newspaper. The newspaper chute 88 may be fastened by suitable means to the support 13 and the front side of the housing 14.

When the operator releases the handle knob 25, the springs 81 pull the pull member 20 in the second direction toward the back side of the housing to move the slide member 22 from the second position to the first position, which is shown in Figure 3. The slide member 22 in moving toward the back side of the housing moves the ejector 11 towards the back side of the housing. The ejector 11 slides from the next adjacent newspaper 76 and on to another newspaper 78. As is best shown in the Figures 3 and 4, the back edge of the ejector on the bottom edges thereof is chamfered to prevent the corners of the ejector digging into the newspaper when it is moved toward the back side of the housing. The notch 68 fits over the back edge 80 of the next adjacent newspaper 76 to prevent it from tipping up or away from the stack. If the newspaper is tipped up from the stack, there is a possibility that it would fall from the stack and be vended before the newspaper ejector is again moved in the forward or first direction. Before the next adjacent newspaper 76 may be vended or further moved from the stack of newspapers, the operator will again have to put another coin into the coin control mechanism 10 to move the ejector 11 forward. Slots 79 in the shelf 13 prevent the pointed fingers 70 from digging into the shelf while the ejector is moved forward to eject the last newspaper in the stack.

In the preferred embodiment of my invention, the newspaper ejector moves in a forward and rearward direction a distance less than one-half the width of the newspaper. It is to be understood that in my specification and claims the word "width" is not to be limited in its meaning, but is to be construed as meaning any one of the dimensions of the newspaper. Thus, the first time the ejector is moved forward the top newspaper is moved to extend less than one-half its width from the stack. The second time and each succeeding time thereafter that the ejector is moved forward, the top newspaper is moved to extend more than one-half its width from the stack and the next adjacent newspaper is moved to extend less than one-half its width from the stack. The top newspaper, extending more than one-half its width from the stack thereby falls into the chute and is delivered to the customer at the mouth or opening in the front of my vending machine.

It is assumed that the weight of a newspaper is evenly distributed throughout the newspaper, and that when the newspaper extends beyond the stack more than $\frac{1}{2}$ its width that portion of the newspaper extending beyond the stack will contain more than $\frac{1}{2}$ the total weight of the newspaper. If the weight is not evenly distributed, the distance of movement may be adjusted to extend more than $\frac{1}{2}$ the weight of the newspaper beyond the stack the second time the ejector moves that newspaper forward. In the case of a newspaper having an uneven distribution of weight, it is to be understood that when I speak of more than $\frac{1}{2}$ width of the newspaper extending beyond the stack, that I include in my meaning the thought of more than $\frac{1}{2}$ the weight extending beyond the stack.

In Figure 8 I illustrate a modification of my

7

newspaper ejector 11. My modified newspaper ejector has the notch 68, as in my preferred embodiment, and also a second notch 73. The notch 68 engages the back edge of the top newspaper. Simultaneously, the notch 73 engages the back edge of the next adjacent newspaper. The operation of a newspaper vending machine having this modified ejector is similar to that of my preferred newspaper vending machine.

Although I have described my invention with a certain degree of particularity in its preferred form, it is understood that the present disclosure of the preferred form has been made only by way of example and that numerous changes in the details of construction and the combination and arrangement of parts may be resorted to without departing from the spirit and the scope of the invention as hereinafter claimed.

What is claimed is:

1. In a newspaper vending machine, a supporting structure including a horizontal shelf having a newspaper supporting portion for supporting a stack of newspapers, an elongated rod slidable endwise and horizontally supported directly over the newspaper supporting portion of said shelf, a runner holding member fastened to and carried by said elongated rod, said runner holding member having vertically disposed guide surface means positioned directly over the newspaper supporting portion of the shelf, an elongated runner held by said holding member and vertically slidable on said guide surface means and having a bottom end descendable towards said shelf, and an ejector on the bottom end of said runner and adapted to engage a newspaper supported by said shelf.

2. In a newspaper vending machine, a supporting structure including a horizontal shelf having a newspaper supporting portion for supporting a

8

stack of newspapers, an elongated rod slidable endwise and horizontally supported directly over the newspaper supporting portion of said shelf, a runner holding member fastened to and carried by said elongated rod, said runner holding member having vertical runner guide grooves positioned directly over the newspaper supporting portions of the shelf with a groove on each side of said rod, a pair of runners held by said holding member with each runner vertically slidable in its respective of said grooves and having bottom ends descendable towards said shelf, and an ejector interconnecting the bottom ends of said runners and adapted to engage a newspaper supported by said shelf.

ARTHUR W. SAWITZKE.

REFERENCES CITED

The following references are of record in the file of this patent:

UNITED STATES PATENTS

Number	Name	Date
536,690	Loewenbach	Apr. 2, 1895
954,873	Moulton	Apr. 12, 1910
1,161,334	Pollock	Nov. 23, 1915
1,314,217	Roberts	Aug. 26, 1919
1,348,012	Lancaster	July 27, 1920
1,477,501	Keenan	Dec. 11, 1923
1,648,813	Kelly	Nov. 8, 1927
1,876,292	Hebb	Sept. 6, 1932
2,119,548	Laughery	June 7, 1938
2,180,326	Traversy	Nov. 14, 1939

FOREIGN PATENTS

Number	Country	Date
23,641	Great Britain	1900
106,426	Great Britain	May 24, 1917