

J. T. MAYER.
 ROCKING LEVER AND PEDAL ARRANGEMENT FOR COMBINATION PIANOS.
 APPLICATION FILED JULY 26, 1910.

999,822.

Patented Aug. 8, 1911.

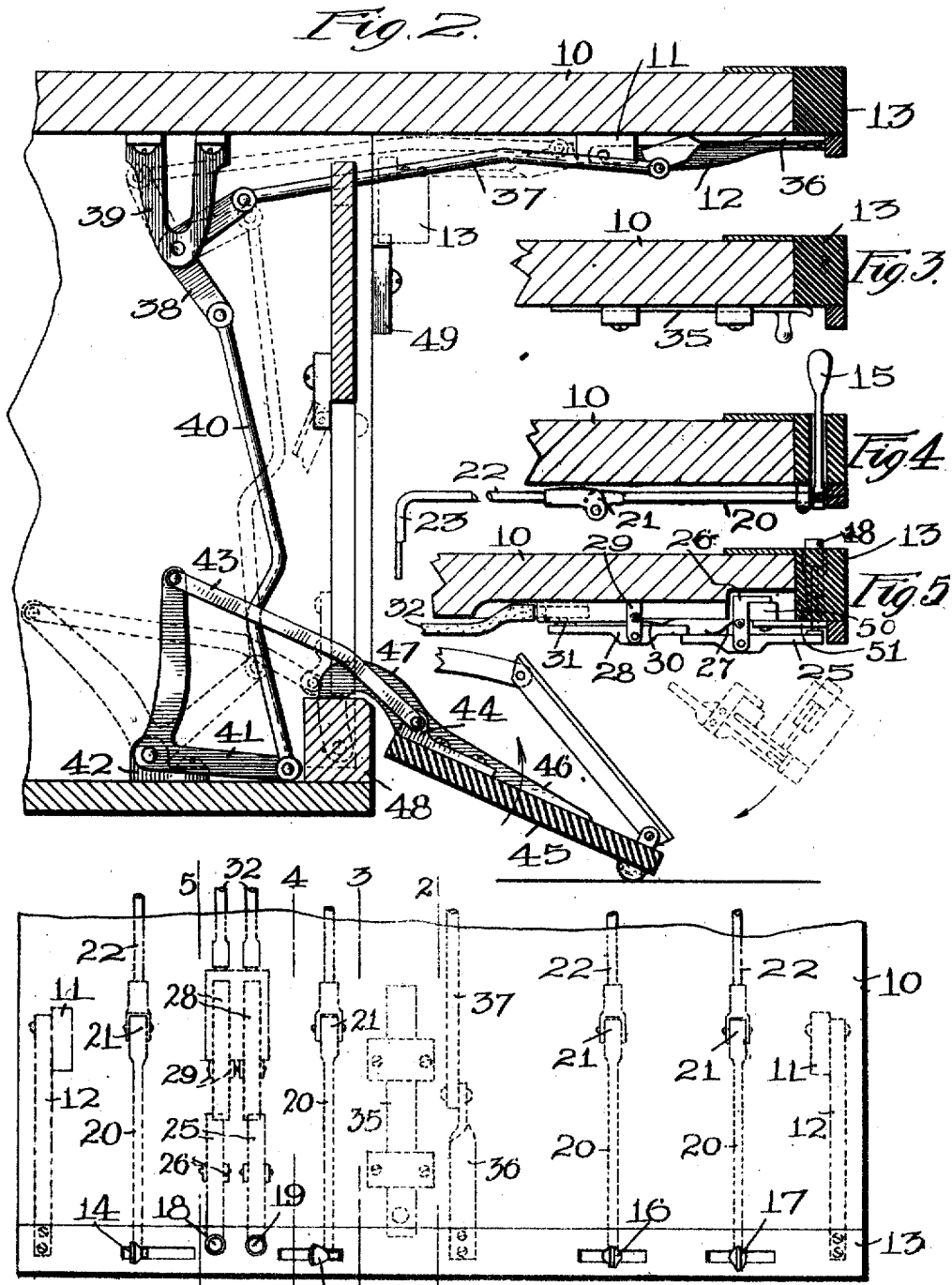

Witnesses:
 C. F. Mason
 S. J. Hartnett

Inventor
 J. T. Mayer
 S. Southgate Southgate.

UNITED STATES PATENT OFFICE.

JULIAN T. MAYER OF NEW YORK, N. Y., ASSIGNOR TO J. & C. FISCHER, OF NEW YORK, N. Y., A CORPORATION OF NEW YORK.

ROCKING LEVER AND PEDAL ARRANGEMENT FOR COMBINATION-PIANOS.

999,822.

Specification of Letters Patent.

Patented Aug. 8, 1911.

Application filed July 26, 1910. Serial No. 573,907.

To all whom it may concern:

Be it known that I, JULIAN T. MAYER, a citizen of the United States, residing at New York, in the county of New York and State of New York, have invented a new and useful Rocking Lever and Pedal Arrangement for Combination-Pianos, of which the following is a specification.

This invention relates to a combination piano capable of being played both automatically and manually.

The principal objects of the invention are to provide means, that will not change the appearance of the instrument when operated upon manually, for holding the expression manipulatory levers and devices; and for concealing the same when the instrument is to be played manually; to provide simple and convenient connections therewith for operating the pedals simultaneously with the motion of the expression devices; and to provide for doing away with the folding key slip, which hides the manipulatory levers and the devices and also any key slip which is cut through, and any part by which the manipulatory levers and devices are exposed to view.

The invention also involves improvements in details of construction and combinations of parts as will appear hereinafter.

Reference is to be had to the accompanying drawings in which—

Figure 1 is a plan of the top of the key bottom of a combination player piano showing the keys and key slip removed and showing the parts below in dotted lines, in accordance with this invention. Fig. 2 is a sectional view on the line 2—2 of Fig. 1 showing the moving connections in elevation. Fig. 3 is a sectional view on the line 3—3 of Fig. 1. Fig. 4 is a sectional view on the line 4—4 of Fig. 1, and Fig. 5 is a sectional view on the line 5—5 of Fig. 1 showing parts in dotted lines in a different position.

The invention is shown as applied to an instrument having a key bottom 10 for supporting the key slip and keys (not shown). On the under side of this are blocks or the like 11 on which are pivoted rocker arms 12 for supporting a rail 13, this rail being fixed rigidly to these rocker arms. The rail is provided with a number of expression manipulatory devices, as for example, in

the form of the levers 14, 15, 16 and 17, and push buttons 18 and 19. These devices may be of any desired kind or type. Whatever their form, they are supported by the rail 13 in such a way that they can be readily manipulated, and can be carried out of sight by the motion of the rail. In the present case the four levers are shown as being mounted on rods 20. Each of these rods has a hinge 21 and a rear section 22 connected therewith, the rear section being provided with an elbow or projecting arm 23 by which they are connected with the usual devices in the instrument. The several hinges 21 are in axial alinement with the pivots on which the rocker arms 12 are pivoted, therefore when the rail 13 swings down on its pivots the rods connected with the several levers will break at the hinges and swing also about the same axis without otherwise changing the relative positions of the parts or straining the joints. The push buttons are shown as each resting on a lever 25 which is hinged on a bracket 26 supported by a block 50 resting on a plate 51 secured to the rail. The lever is provided with a spring 27 for holding the front end and the push button up. The rear end of this lever 25 projects under a similar lever 28 pivoted on a bracket 29 fixed under the key bottom and having a spring 30 for holding its front end down. The rear end of the lever 28 operates a valve 31 for admitting air to a conduit 32 which leads to any desired part of the instrument for controlling the same. The operation of these parts is very simple. When the parts are at rest, the valve 31 is closed by the action of the spring 29. When the button is pressed down, the rear end of the lever 25 is lifted which depresses the valve 31 and lets air into the conduit 32. The bracket 26 being fixed to the rail 13 and the bracket 29 to the key bottom, it will be seen that the bracket 26 and lever 25 will swing down with the rail away from the lever 28 and leave that in its normal position with the valve closed.

I have shown a latch 35 for holding the rail up. The rail is also provided with an arm 36 projecting rearwardly therefrom and pivotally connected, at a point between the line of pivots above mentioned and the rail, to a rod 37 which extends back into the case.

This rod is pivoted to a bell-crank 38 supported by a bracket 39. The bell crank in turn is connected by a rod 40 with a bell-crank 41 pivoted on a bracket 42 near the bottom of the case. The other arm of this bell-crank is connected by a link 43 with a bracket 44 connected with the pedals 45. The pedals are provided with side brackets 46 having goose necks 47 which extend down into the case and are pivoted inside the bottom rail 48. It will be seen from this construction that the operation of turning the rail 13 down from the position shown in full lines in Fig. 1 to the position in which it is folded back, as shown in dotted lines in Fig. 1, will operate the several links, levers and bell-cranks to lift the pedals and bring them into closed position in the case, as also is shown in dotted lines in Fig. 2. When the parts are in this position, the rail and connected parts are folded back in horizontal position directly under the rear of the bottom, and they can be held by a latch 49 engaging the bottom of the rail 13. This leaves the instrument in a condition in which the presence of the controlling levers and the like would never be suspected from the front, and do not interfere with the operation of the ordinary pedals and the like. In this way the lowering of the pedals is accomplished in a very simple manner without reaching down or even operating any lever or handle except the front rail. This greatly simplifies the manipulation of the device and leaves the automatic playing device thoroughly concealed when the instrument is to be played manually.

While I have illustrated and described a preferred embodiment of the invention, I am aware that many modifications can be made therein by any person skilled in the art without departing from the scope of the invention as expressed in the claims. Therefore, I do not wish to be limited to all the details of construction or their exact arrangement herein shown and described, but

What I do claim is:—

1. In an instrument of the class described, the combination with the case and key bottom, of a front rail constructed to swing about pivots, a push button on said rail, a lever supported by the rail and operated by the push button, a second lever supported by the key bottom in position to be operated by the first lever and projecting under it, and a

valve connected with and operated by the second lever.

2. In an instrument of the class described, the combination with the case and key bottom, of a front rail adapted to swing about pivots located under the key bottom, expression manipulatory levers carried by said rail, rods under the key bottom to which said levers are connected, each of said rods having a hinge in axial alinement with said pivots, a push button on said rail, a lever supported by the rail and operated by the push button, a second lever supported by the key bottom in position to be operated by the first lever, and a valve connected with and operated by the second lever.

3. In an instrument of the class described, the combination with the case and key bottom, of a front rail adapted to swing about pivots located under the key bottom, expression manipulatory levers carried by said rail, a push button on said rail, a lever supported by the rail and operated by the push button, a second lever supported by the key bottom in position to be operated by the first lever, and a valve connected with and operated by the second lever.

4. In an instrument of the class described, the combination with the key bottom, of a movable front rail, a push button on said rail, a spring pressed lever on said rail normally holding said button up, a spring pressed lever on the key bottom in engagement with the first named lever when the rail is in operative position, a valve normally held closed by the second lever, and means whereby the rail can be moved back under the key bottom and the lever thereon carried away from the second lever.

5. In an instrument of the class described, the combination with the case and key bottom, of a front rail guided to move under the key bottom, a push button on said rail, a lever supported by the rail and operated by the push button, a second lever supported by the key bottom in position to be operated by the first lever, and a valve connected with and operated by the second lever.

In testimony whereof I have hereunto set my hand, in the presence of two subscribing witnesses.

JULIAN T. MAYER.

Witnesses:

E. J. PRINGLE,
B. H. POTTER.