

(19) **DANMARK**

(10) **DK/EP 3199828 T3**



(12) **Oversættelse af  
europæisk patentskrift**

Patent- og  
Varemærkestyrelsen

- 
- (51) Int.Cl.: **F 16 D 65/097 (2006.01)**
- (45) Oversættelsen bekendtgjort den: **2021-09-27**
- (80) Dato for Den Europæiske Patentmyndigheds bekendtgørelse om meddelelse af patentet: **2021-08-25**
- (86) Europæisk ansøgning nr.: **17150154.7**
- (86) Europæisk indleveringsdag: **2017-01-03**
- (87) Den europæiske ansøgnings publiceringsdag: **2017-08-02**
- (30) Prioritet: **2016-01-15 DE 102016100623**
- (84) Designerede stater: **AL AT BE BG CH CY CZ DE DK EE ES FI FR GB GR HR HU IE IS IT LI LT LU LV MC MK MT NL NO PL PT RO RS SE SI SK SM TR**
- (73) Patenthaver: **BPW Bergische Achsen KG, Ohlerhammer, 51674 Wiehl, Tyskland**
- (72) Opfinder: **DOWE, Günter, Langwiese 20, 51588 Nümbrecht, Tyskland**
- (74) Fuldmægtig i Danmark: **Patrade A/S, Ceresbyen 75, 8000 Århus C, Danmark**
- (54) Benævnelse: **BREMSEKLODSHOLDER TIL EN SKIVEBREMSE PÅ ET KØRETØJ SAMT TILHOLDER TIL FASTGØRELSE AF BREMSEKLODSER**
- (56) Fremdragne publikationer:  
**DE-A1-102007 041 658**  
**DE-A1-102008 027 052**  
**DE-A1-102009 030 414**  
**DE-A1-102010 043 898**  
**DE-A1-102013 008 161**



## Description

The invention relates to a brake pad holder of a vehicle disc brake according to the preamble of Patent Claim 1 and to a hold-down device for the fixing of brake pads  
5 in a disc brake according to the preamble of Patent Claim 10.

Disc brakes having a brake calliper are known from DE 10 2005 044 091 A1 and DE 10 2013 100 162 A1, said brake calliper engaging over a brake disc and brake pads arranged on both sides thereof. An elongate hold-down device in the form of  
10 a rigid bracket extends transversely over the brake pads and applies a spring force to said brake pads. The one end of the hold-down device is fixed directly in an opening of the brake calliper, whereas the other end region of the hold-down device is fixed to the brake calliper by means of a bolt. In order to connect to the bolt, the hold-down device is provided with a fixing opening in this end region, said fixing  
15 opening extending radially in respect of the brake disc.

Document DE 10 2008 027 052 A1 discloses a brake holder with a hold-down device which has a fixing opening at each of its two ends.

20 The problem addressed by the invention is that of developing a brake pad holder of a disc brake, such that the parts required for this can be produced cost-effectively and the assembly and dismantling of the brake pads can easily be carried out. Furthermore, a suitable hold-down device for a brake pad holder of this kind is to be created.

25 In order to solve this problem, a brake pad holder of a vehicle disc brake according to Claim 1 and a hold-down device for fixing brake pads in a disc brake according to Claim 10 is proposed.

30 In the proposed solutions, the hold-down device is provided with a completely, or almost completely, closed fixing opening on the outside of the vehicle, the central axis of which extends in the direction of the width of the hold-down device and

therefore in the brake pad circumferential direction. A bolt which connects the hold-down device to the brake calliper can be passed through this fixing opening, wherein the bolt also extends in the direction of the width of the hold-down device and therefore in the brake disc circumferential direction.

5

In order to receive the bolt, the fixing opening, which may have a one-part or two-part design, preferably has a round opening cross section.

Disc brakes are usually arranged as far as possible towards the outside of the vehicle for a space-saving arrangement. This results in parts of the disc brake already being located within the braked vehicle wheel. At the same time, in order to achieve high braking performance, the aim is for the brake disc of the disc brake to have the largest possible dimensions. However, this aim results in only a small clearance remaining between the components of the disc brake and the vehicle wheel rotating about the brake. It is not unusual, therefore, for there to be a grinding of brake parts which lie radially far outwards on the rotating inner surface of the vehicle wheel when additional bending loads occur.

It is therefore proposed with an embodiment of the hold-down device according to the invention that the upper side thereof is formed along the hold-down device longitudinal centre line as an elongated base, and that the central axis of the fixing opening is located beneath said base. This then has the advantage that in this region, namely the corresponding end region of the hold-down device, disc brake parts project radially less far outwardly and a contribution is therefore made to mitigating the structural closeness to the surrounding vehicle wheel rotating about the brake.

The fixing opening is created according to a first variant in accordance with the invention by an eye which is composed of a material section of the hold-down device formed through at least 300°. In the event that the hold-down device is made of sheet metal, the eye is preferably composed of a material section of the sheet metal formed through almost 360°, wherein the residual gap still remaining to this extent is metallurgically closed, preferably by a spot weld or soldering point.

30

A two-part configuration of the fixing opening is proposed according to the invention, consisting of a first fixing opening, e.g. in the form of an eye, a second fixing opening in alignment with the first fixing opening, e.g. in the form of an eye, and a clearance arranged therebetween, into which a holder formed on the brake  
5 calliper projects. The two fixing openings in this case are preferably each created by an eye.

According to a second variant in accordance with the invention, the fixing opening is created by a pipe which is a constituent part of the hold-down device and the axis  
10 of said pipe extends in the brake disc circumferential direction.

According to one embodiment of the hold-down device, said device is configured over a large part of its total length as a trough with an elongated base and side  
15 flanks arranged on the sides of said base. Only the base is connected to the pipe, whereas the side flanks end spaced apart from said pipe. The pipe is preferably fixed to the base in a substance-bonded manner, e.g. welded to the base.

According to the invention, the pipe has a length that is greater than the width of the hold-down device over the remaining longitudinal extent thereof.  
20

Exemplary embodiments are explained in greater detail below with the help of the drawings. In the drawings:

Fig. 1 shows a perspective representation of the brake calliper of a vehicle disk  
25 brake, including the pad channel formed in the brake calliper with brake pads arranged therein, and also a hold-down device above the pad channel;

Fig. 2 shows the objects according to Fig. 1 in a centrally positioned longitudinal section through the calliper;  
30

Fig. 3 shows a perspective representation only of the hold-down device of the hold-down arrangement that can be fixed to the brake calliper;

Fig. 4 shows a side view of the hold-down device according to Fig. 7;

Fig. 5 shows in a second embodiment a perspective representation of the brake calliper of a vehicle disc brake, including the pad channel formed in the brake calliper with brake pads arranged therein, and also a hold-down arrangement above the pad channel;

Fig. 6 shows the objects according to Fig. 5 in a centrally positioned longitudinal section through the calliper;

10

Fig. 7 shows a perspective representation only of the hold-down device of the hold-down arrangement that can be fixed to the brake calliper;

Fig. 8 shows a perspective representation of a third embodiment of the hold-down device.

15

The drawings show the brake calliper 1 of a vehicle disc brake for commercial vehicles. The disc brake may be of the floating-calliper or fixed-calliper type. A brake pad 3 is arranged on either side of the brake disc of the disc brake reproduced only with the help of its rotational axis A. In order to receive the brake pads 3, the brake calliper is provided with a pad channel 6 over which a bracket-shaped pad hold-down device 7 extends. Said pad hold-down device spans the pad channel 6 such that the pad hold-down device 7 extends transversely over both brake pads 3.

20

As is customary, each brake pad 3 is made up of the actual friction pad 4 and a back plate 5. The back plate 5 is used for improved distribution of the brake pressure over the pad surface. Moreover, it is responsible for the guidance and support of the brake pad either on the brake calliper 1 itself or on a fixed-axle brake carrier of the disc brake.

25

The pad hold-down device 7 reproduced as an individual component in Fig. 3 and Fig. 4 has an elongate design, wherein its longitudinal centre line M extends parallel to the rotational axis A of the brake disc. Its length in the direction of the

30

rotational axis A is substantially greater than its width B extending in the brake disc circumferential direction.

5 The end of the hold-down device 7 on the inside of the vehicle, as reproduced on the right, is fixed to the brake calliper 1 directly, for which purpose this end sits in a slot-shaped recess 14 in the brake calliper 1. The end of the hold-down device 7 on the outside of the vehicle, as reproduced on the left, is fixed to the brake calliper 1 indirectly using a bolt 13; this will be explained in greater detail below.

10 In order to secure the two brake pads 13 in the pad channel 6, the hold-down device 7 is configured as a rigid holding bracket which extends transversely over the pad channel 6.

15 According to Fig. 1, the hold-down device 7 is combined with two flexible hold-down springs 9. The problem addressed by the hold-down arrangement configured in this manner is that of fixing both brake pads in respect of the pad channel 6, in such a manner that the brake pads cannot emerge or fall from the pad channel 6 radially outwardly in respect of the rotational axis A of the brake pad.

20 The rigid hold-down device 7 has a trough-shaped cross section over the majority of its total length with a base 7C arranged on the longitudinal centre line M, to which side flanks 8A, 8B are attached along both longitudinal edges of the base 7C, as a result of which this central longitudinal section of the hold-down device is reinforced in respect of bending forces. The flanks 8A, 8B are formed as ascending  
25 slopes. In this way, the hold-down device 7 has over this majority of its length a roughly trapezoidal cross section and, in particular, the cross section of a trapezoidal trough. The angle at which the side flanks 8A, 8B are arranged in relation to the flat base of the trough is between 15° and 90°, in the case of the exemplary embodiment roughly 20°.

30

Each of the two hold-down springs 9 made of sprung steel extends parallel to the back plate 5 in each case. Each hold-down spring 9 is supported from below in its centre against the hold-down device 7, while it is supported at its ends on the upper

edge 25 of the back plate 5 in each case. In this way, the hold-down device 7 exerts a spring force on the brake pads 3 by means of the hold-down springs 9 which forces said brake pads 3 in the direction of the rotational axis A.

5 Proximate to its one end, the hold-down device 7 has a width B1 and is narrower than on its longitudinal trough-shaped section where the hold-down device has a width B. The longitudinal section with the smaller width B1 is arranged as an extension of the elongated base 7C. A pipe 10 is fixed to this longitudinal portion transversely to the longitudinal centre line M, said pipe extending in the direction  
10 of the width B of the hold-down device. The axis of the pipe 10 therefore extends in the brake disc circumferential direction. By contrast, the side edges 8A, 8B preferably end spaced apart from the tube 10.

The cylindrical opening cross section of the pipe 10 forms a continuous fixing  
15 opening 11 in the direction of the width B. This receives the cylindrical bolt 13 which connects the hold-down device 7 to the brake calliper 1. The central axis MB of the fixing opening 11 lies deeper, namely below the plane of the base 7C.

The pipe 10 is preferably connected to the base 7C of the hold-down device 7 by  
20 welding. The wall thickness of the pipe 10 is smaller than the wall thickness of the steel sheet from which the hold-down device 7 is produced by punching and forming. Alternatively, the hold-down device may also be produced as a casting.

For the fixing of the bolt 13 on the calliper side, two holders 50 are arranged on the  
25 brake calliper 1. The holder 50 in this case is made up of two bearing mountings integrally formed on the brake calliper 1. They each have a bore through which the bolt 13 is passed. So that the bolt 13 cannot become detached from the holders 50, and therefore from the calliper, in the longitudinal direction of the bolt, suitable circlips, split pins or similar measures are provided on the bolt 13.

30

The bolt 13 penetrates both the two openings in the bearing mountings 50 which are in alignment with one another and, on the centre axis MB, the fixing opening 11 in the pipe 10. In this case, the pipe 10, which exhibits the length L, is arranged

between the two bearing mountings 50 and lies with its one end face on the one bearing mounting 50, and with its other end face on the other bearing mounting 50 in a clearance-free manner or with a small amount of clearance.

5 Figures 5 – 7 show an alternative embodiment in which the pipe 10 is not configured as a closed pipe across its entire length and over its entire circumference, but is provided with a side opening 12 limited to a centre section. In this way, the weight proportion of the pipe 10 on the hold-down device 7, and therefore also the weight of the hold-down device 7, can be reduced. In addition, the opening 12 may  
10 be helpful in creating space in relation to directly adjacent surfaces or contours of the calliper 1.

In its other end region located inside the vehicle, the hold-down device 7 is configured in such a manner that this hold-down end is supported against the brake  
15 calliper 1 in the circumferential direction. For this purpose, the hold-down device 7 is provided at this end with a centre section 70 extending along its longitudinal centre line M and continuing the base 7C, and also with a side section 71 and 72 on either side of the centre section 70 in each case. The side sections 71, 72 form an extension of the side flanks 8A, 8B of the hold-down device configured as a  
20 trough and have, viewed in the longitudinal direction of the hold-down device, towards the ends thereof, an upwardly curved, hook-shaped profile. In this way, on each side section 71, 72 an inner surface 77 arranged above the plane of the base 7C is formed.

25 For the purpose of resting against mating surfaces 81 formed on the brake calliper 1, the two inner surfaces 77 are turned to one another in such a manner that there is a clearance between them. The support on the mating surfaces 81 can be free from clearance, or there may be a limited lateral clearance in the circumferential direction of the brake disc.

30

In order to produce the curved side sections 71, 72 by forming the sheet steel from which the hold-down device 7 is produced, the side sections 71, 72 are each separated from the centre section 70 by a longitudinal section 73, 74 which is only

open to the relevant end of the hold-down device. Only the centre section 70 projects into the slot 14 in the brake calliper 1, whereas the side sections 71, 72 are located outside the slot. So that the inner surfaces 77 can rest on the brake calliper 1 in the direction of the width B, said calliper 1 is provided with corresponding mating surfaces 81 facing away from one another above the slot 14.

Fig. 8 shows a third variant of the hold-down device. Instead of a pipe or tube, the fixing opening 11 is created by a total of two eyes 10A, 10B, wherein each of the two eyes is composed of a material section of the hold-down device 7 formed through almost 360°.

The residual gap 85 still remaining as a result of this forming can be closed metallicity, in order to reinforce the eye 10A, 10B, preferably by a spot weld or soldering point placed in the region of the gap 85.

A two-part embodiment of the fixing opening 11 comprising a first fixing opening 11 in the first eye 10A, a second fixing opening 11 in the second eye 10B, which is in alignment with the first fixing opening, and a clearance 90 arranged between the eyes is therefore produced in this case. The bearing mounting formed on the brake calliper 1 and acting as a holder projects into this clearance 90. This bearing mounting may be comparable with the bearing mountings 50 according to Figures 1, 2, 5 and 6, but it is only present once and arranged centrally as an extension to the longitudinal centre line M of the hold-down device 7. It can project into the clearance 90 but must leave the bolt 13 with sufficient space for it to be assembled.

The length L measured between the end faces of the two eyes 10A, 10B facing away from one another is greater than the width B of the hold-down device 7 on the remaining longitudinal extent thereof.

**List of reference numbers**

	1	Brake calliper
	3	Brake pad
5	4	Friction pad
	5	Back plate
	6	Pad channel
	7	Hold-down device
	7C	Base
10	8A	Side flank
	8B	Side flank
	9	Hold-down spring
	10	Pipe
	10A	Eye
15	10B	Eye
	11	Fixing opening
	12	Opening
	13	Bolt
	14	Slot, recess
20	25	Edge
	50	Holder, bearing mounting
	70	Centre section
	71	Side section
	72	Side section
25	73	Longitudinal slot
	74	Longitudinal slot
	81	Mating surface on the brake calliper
	85	Gap
	90	Clearance
30		
	A	Rotational axis of the brake disc
	B	Width
	B1	Width

- L Pipe length
- M Longitudinal centre line
- MB Fixing opening centre axis

**Patentkrav**

- 5  
10  
15  
20  
25  
30  
35
- 1.** Bremsklodsholder til en skivebremse på et køretøj med bremsklodser (3) indvendigt og udvendigt på køretøjet anbragt på begge sider af en bremseskive i en klodskanal (6) på en bremskaliber (1), samt med en tilholder (7) tværs over bremsklodserne (3), som støttes indirekte imod skivebremseaksen (A) eller direkte mod bremsklodserne (3) og har et endeområde i begge sine ender, med hvilket tilholderen (7) støttes i forhold til bremskaliberen (1), hvor tilholderen (7) i et af endeområderne er forsynet med en fuldstændig eller næsten fuldstændig lukket fastgørelsesåbning (11), hvis midterakse (MB) strækker sig i bremseskivens omkredsretning, **kendetegnet ved, at** fastgørelsesåbningen (11) befinder sig på køretøjets yderside, at oversiden af tilholderen er udformet langs tilholderlængdemidterlinjen (M) som en langstrakt basis (7C), og at fastgørelsesåbningens (11) midterakse (MB) befinder sig under basis (7C).
  - 2.** Bremsklodsholder ifølge krav 1, **kendetegnet ved, at** fastgørelsesåbningen (11) har et rundt åbningstværsnit og omslutter en bolt (13), som forbinder tilholderen (7) med bremskaliberen (1).
  - 3.** Bremsklodsholder ifølge krav 1 eller 2, **kendetegnet ved, at** fastgørelsesåbningen er dannet af et øje (10A, 10B), som består af et materialeafsnit af tilholderen (7) deformeret med mindst 300°.
  - 4.** Bremsklodsholder ifølge krav 3, **kendetegnet ved, at** tilholderen (7) består af en fast metalplade og øjet (10A, 10B) af et materialeafsnit af metalpladen, som er deformeret med næsten 360°, hvor den således resterende spalte (85) er metallisk forsejlet, foretrukket via et svejse- eller lodningspunkt.
  - 5.** Bremsklodsholder ifølge et af de foregående krav, **kendetegnet ved** en to-delt udformning af fastgørelsesåbningen (11) bestående af en første fastgørelsesåbning i form af et øje (10A), en anden fastgørelsesåbning i form af et øje (10B), som flugter med den første fastgørelsesåbning, og et tomt rum (90) anbragt mellem øjerne (10A, 10B), som en holder (50) udformet på bremskaliberen (1) stikker ind i.
  - 6.** Bremsklodsholder ifølge krav 1 eller 2, **kendetegnet ved, at** fastgørelsesåbningen (11) udgøres af et rør (10), hvis rørakse strækker sig i bremseskivens

omkredsretning.

5 **7.** Bremseskodsholder ifølge krav **6, kendetegnet ved, at** tilholderen (7) for en stor del af sin samlede længde er udformet som en rille af en langstrakt basis (7C) og sideflanker (8A, 8B) anbragt på siderne af basis (7C), hvor kun basis (7C) er forbundet med røret (10), mens sideflankerne (8A, 8B) ender med afstand til røret (10).

10 **8.** Bremseskodsholder ifølge krav **7, kendetegnet ved, at** røret (10) er integreret forbundet med basis (7C).

15 **9.** Bremseskodsholder i følge et af kravene 6 - 8, **kendetegnet ved, at** røret (10) har en rørlængde (L), som er større end bredden (B) af tilholderen (7) i dennes øvrige længdeudstrækning.

20 **10.** Tilholder (7) til fastgørelse af bremseskodser i en skivebremse med en længdeudstrækning og en i forhold hertil væsentligt mindre bredde (B), og med et første endeområde og et andet endeområde, hvor tilholderen (7) i et af endeområderne er forsynet med en fuldstændig eller næsten fuldstændig lukket fastgørelsesåbning (11), hvis midterakse (MB) strækker sig i retning af bredden (B) af tilholderen (7), **kendetegnet ved, at** oversiden af tilholderen er udformet langs tilholder-længdemidterlinjen (M) som en langstrakt basis (7C), at fastgørelsesåbningens (11) midterakse (MB) befinder sig under basis (7C), og at fastgørelsesåbningen (11)

25 - enten udgøres af en todelt udformning af fastgørelsesåbningen (11) bestående af en første fastgørelsesåbning i form af et øje (10A), en anden fastgørelsesåbning i form af et øje (10B), som flugter med den første fastgørelsesåbning, og et tomt rum (90) anbragt mellem øjerne (10A, 10B), hvor øjerne (10A, 10B) består af et materialeafsnit af tilholderen (7) deformeret med mindst 300°,

30 - eller udgøres af et rør (10), hvis rørakse strækker sig i retning af bredden (B) af tilholderen (7), hvor røret (10) har en rørlængde (L), der er større end bredden (B) af tilholderen (7) i dennes øvrige længdeudstrækning.

35 **11.** Holder ifølge krav 10, **kendetegnet ved, at** fastgørelsesåbningen (11) har et rundt åbningstværsnit.

**12.** Tilholder ifølge et af kravene 10 eller 11, **kendetegnet ved, at** tilholderen (7) består af en fast metalplade, og øjerne (10A, 10B) af et materialeafsnit af metalpladen, som er deformeret med næsten 360°, hvor den således resterende spalte (85) er metallisk forsejlet, foretrukket via et svejse- eller lodningspunkt.

5

**13.** Tilholder ifølge krav 10 eller 11, **kendetegnet ved, at** tilholderen (7) for en stor del af sin samlede længde er udformet som en rille af en langstrakt basis (7C) og sideflanker (8A, 8B) anbragt på siderne af basis (7C), hvor kun basis (7C) er forbundet med røret (10), mens sideflankerne (8A, 8B) ender med afstand til røret (10).

10

**14.** Tilholder ifølge krav 13, **kendetegnet ved, at** røret (10) er integreret forbundet med basis (7C).

15

**15.** Tilholder ifølge et af kravene 10 til 14, med undtagelse af krav 12, **kendetegnet ved, at** rørets (10) vægtykkelse er mindre end materialetykkelsen af den resterende tilholder fremstillet af metalplade.

20

**16.** Tilholder ifølge et af kravene 10 til 15, med undtagelse af krav 12, **kendetegnet ved, at** røret (10), er forsynet med mindst en sideåbning (12) begrænset til et rørafsnit i midten.

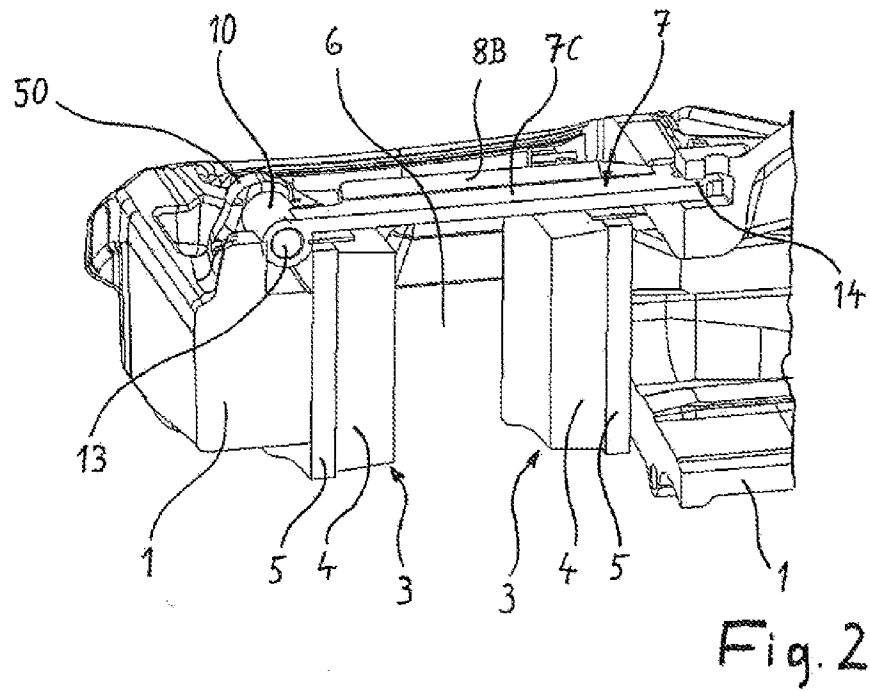
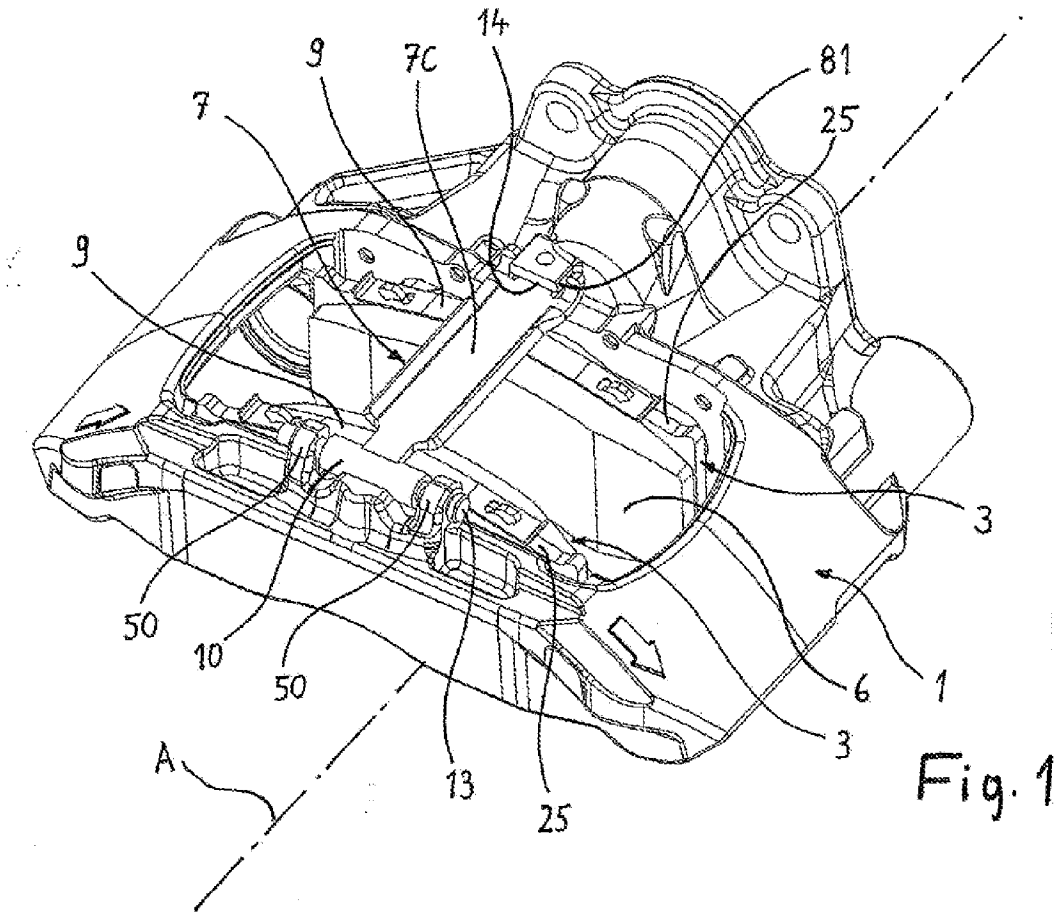

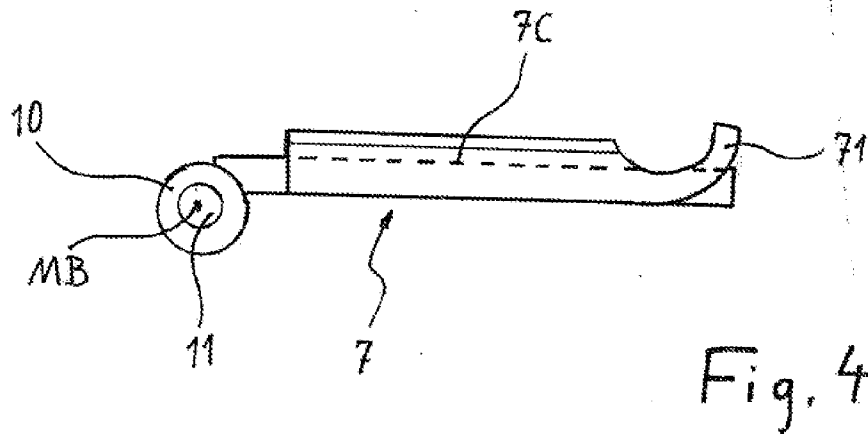
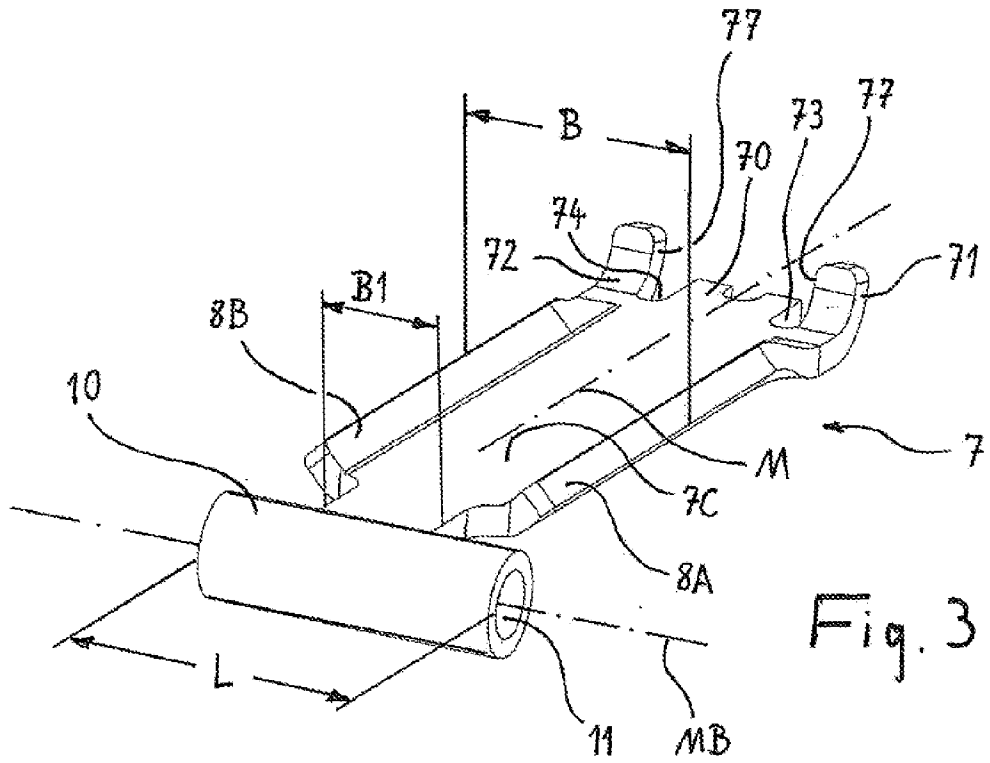

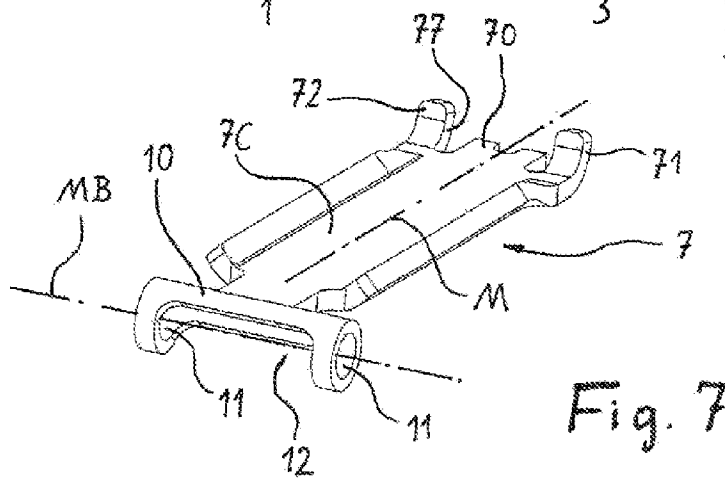
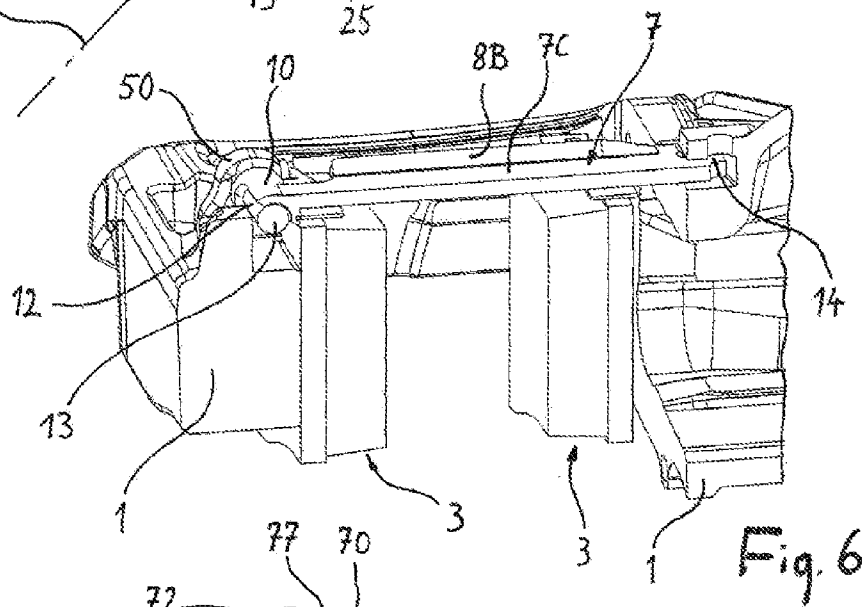
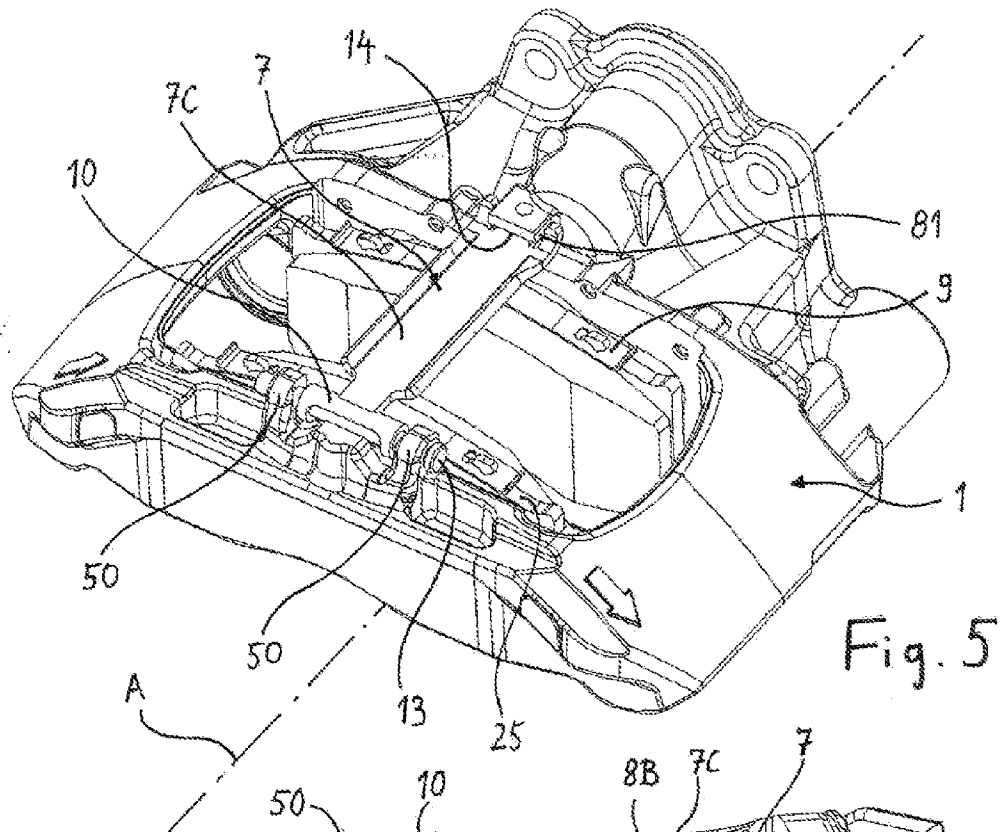

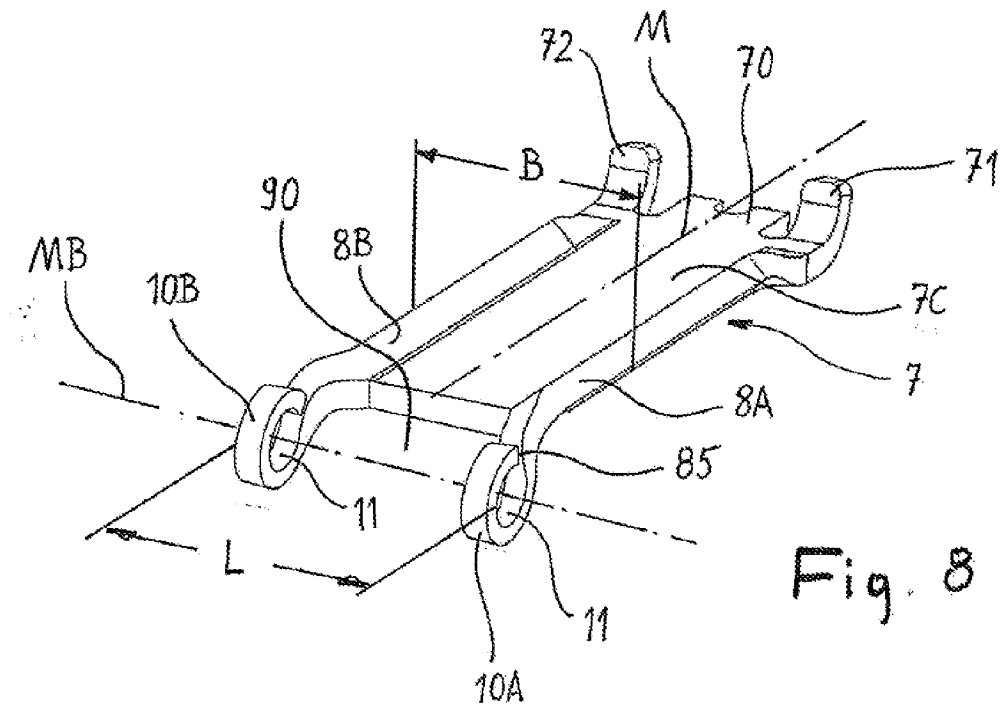

Fig. 8