

(No Model.)

2 Sheets—Sheet 1.

M. QUISENBERRY. AUTOMATIC FLOOD GATE.

No. 433,366.

Patented July 29, 1890.

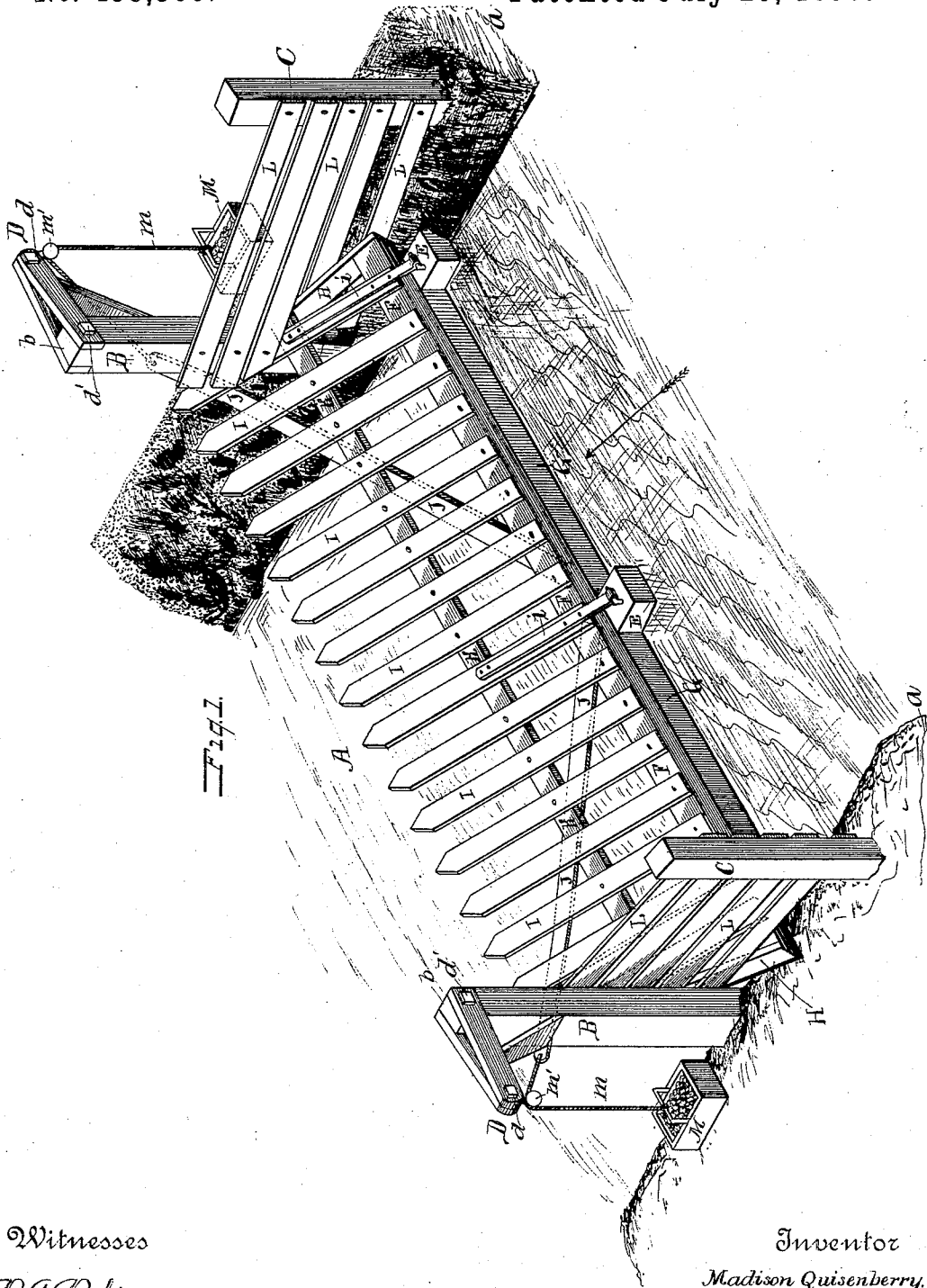

Witnesses

R. A. Balderson

H. C. Johnson

Inventor

Madison Quisenberry.

By His Attorneys

Wigdon & Wigdon

M. QUISENBERRY.
AUTOMATIC FLOOD GATE.

No. 433,366.

Patented July 29, 1890.

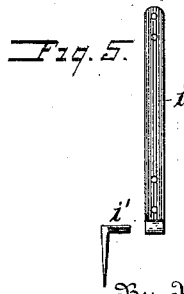
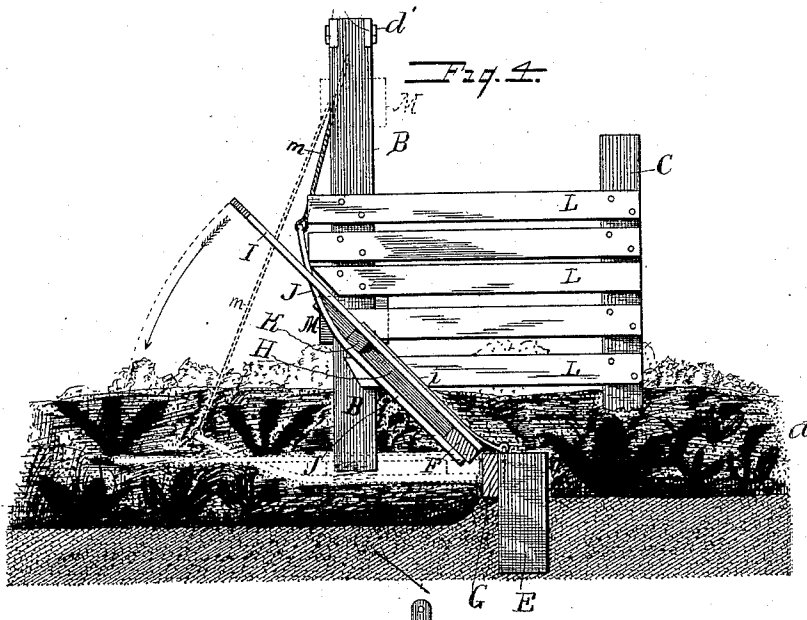
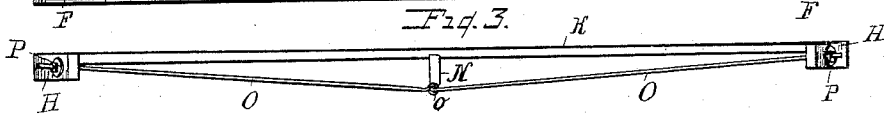
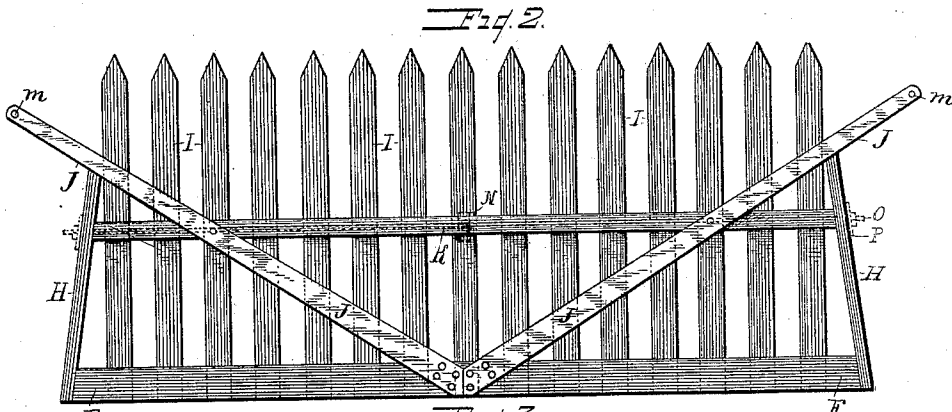

Witnesses
R. A. Balderson
H. C. Johnson

Inventor
Madison Quisenberry

By His Attorneys
Higdon & Higdon

UNITED STATES PATENT OFFICE.

MADISON QUISENBERRY, OF RAYMORE, MISSOURI.

AUTOMATIC FLOOD-GATE.

SPECIFICATION forming part of Letters Patent No. 433,366, dated July 29, 1890.

Application filed October 24, 1889. Serial No. 327,993. (No model.)

To all whom it may concern:

Be it known that I, MADISON QUISENBERRY, of Raymore, Cass county, Missouri, have invented certain new and useful Improvements in Automatic Flood-Gates, of which the following is a full, clear, and exact description, reference being had to the accompanying drawings, forming a part hereof.

My invention relates to automatic flood-gates; and it consists in the novel construction and parts hereinafter set forth and described.

The object of my invention is to provide a means of closing gaps in a fence where it crosses small streams of water, which, on occasions of heavy falls of rain, suddenly rise, thereby making it impossible to construct an ordinary fence which would stand the freshet across the stream.

My flood-gate is so constructed by means of substantial posts set in the ground, to which the gate is firmly secured by heavy wrought-iron hinges, and posts and weights at either side firmly attached to the gate, as to keep it in an upward closed position, except when the water is very high. In times of freshet the water rushes over the gate and presses it down in a position parallel with the bed of the stream, and as the water recedes the weights located at either end of the gate bring the gate back to the position for which it is designed, closing the gap in the fence caused by the stream.

Figure 1 is a perspective view of my improved flood-gate, showing the general construction of the same. Fig. 2 is an elevation of the under side of the gate. Fig. 3 shows a detail view of the central horizontal timber and truss-braces. Fig. 4 is a view, partly in section, showing the operation of my improved gate; and Fig. 5 is a detail view of the hinge.

Posts C and C' are set in the ground a few feet up the stream from posts B B, with fence-boards L reaching from one to the other, closing up the gap between them and posts B, and also forming a chute for the water and drift-wood to pass over the gate.

A is the gate; B, the post to which the weights are suspended; C, an ordinary brace-

50 post.

E are posts set firmly in the bed of the stream—one in the center and one at each side—to which the gate is hung.

F is a timber at the lower edge of the gate, forming the hanger, to which the slats of the gate are made fast. 55

G is a sill spiked fast to the short posts horizontally across the bed of the stream. This sill is designed to close up the open space below the gate in seasons of very low water. 60

I I are the slats of the gate.

J J are strong braces securely attached at each end, the two lower ends extending inward to the center of the gate, the upper ends extending outward, to each of which a rope is secured, carrying a weight, which weights operate the gates. These braces are made very strong and are firmly secured to the gate, the main object of them being to carry the weight of the gate and prevent it from sagging. 65 70

K is another horizontal timber, to which the slats of the gate are made fast.

H are braces, which are rigidly secured to the bottom timber F, to the center timber K, and to the braces J. The object of these braces is to make the gate more solid at the ends. 75

m m' are the weight-ropes and pulleys, respectively; D, the extreme end of the bracket to which the pulley is attached; d, a bolt that holds the pulley in position. 80

a a are the banks of the stream; i i, the hinges of the gate. The gate is braced by means of the truss-rods O O, linked at the center and bearing upon the king-pin N, the free ends of the truss-rods passing through the pieces H, and there secured by means of the nuts P P. 85 90

Having thus described my invention, what I claim as new, and desire to protect by Letters Patent of the United States, is—

In a flood-gate, the combination, with posts E sunk in the bed of the stream, of the gate A, hinged thereto, said gate consisting of the horizontal timbers F and K, slats I, and pieces H, and braced by the truss-rods O and king-pin N, as described, the upwardly and outwardly extending braces J, the posts B, sunk 100

in the banks of the stream and provided with horizontal brackets D, pulleys *m'*, supported from said brackets, ropes *m*, connected to the free ends of the brackets J and passing over
5 the pulleys *m'*, and the weights M, attached to the ends of the ropes, substantially as and for the purpose described.

In testimony whereof I affix my signature in presence of two witnesses.

MADISON QUISENBERRY.

Witnesses:

S. CAMPBELL,

ALEX KING.