



(19) **United States**

(12) **Patent Application Publication**
Choi

(10) **Pub. No.: US 2004/0237990 A1**

(43) **Pub. Date: Dec. 2, 2004**

(54) **DEVICE FOR CURLING HAIR**

(76) Inventor: **Tae-Gyoo Choi**, Incheon (KR)

Correspondence Address:
Lee, Hong, Degerman,
Kang & Schmadeka
14th Fl.
801 S. Figueroa St.
Los Angeles, CA 90017 (US)

(21) Appl. No.: **10/884,024**

(22) Filed: **Jul. 2, 2004**

(30) **Foreign Application Priority Data**

Feb. 7, 2003 (KR) 2003-44564

Publication Classification

(51) **Int. Cl.⁷** **A45D 1/00**

(52) **U.S. Cl.** **132/224**

(57) **ABSTRACT**

The present invention is directed to a device for curling hair comprising means for rotating the heads wherein a guide groove is formed at a bottom surface of the other end in each grip, receiving groove is formed at an upper surface of the other end in each grip, and each receiving groove has a step

portion and a through hole at a center thereof, wherein an end of a cover in each head is bent to form a guide to be inserted into the guide groove of each grip, a connecting piece is coupled with each cover by bolt, and each connecting piece has a recess and an irregular portion formed at a bottom surface of the recess, and wherein an intermitting piece having an irregular portion formed at an upper surface thereof is accommodated in the recess of each connecting piece and is fastened to a button provided to each head by a bolt, a pushing part is provided between a bottom surface of each button and the step portion of each receiving groove supported by a spring, and each connecting piece is separated from each intermitting piece by pushing the each pushing part so as to allow each head to freely rotate. Alternatively, the device according to the present invention comprises means for rotating the heads wherein a motor and a worm gear are accommodated in a receiving part of each grip, the motor is driven in both of a regular and a reverse direction and the worm gear is connected with the motor by a timing belt, a spur gear is formed integrally with one end of a cover in each head, and the spur gear is rotatably coupled to the other end of each grip by a bolt and is engaged with the worm gear. Preferably, the heating plate is coated with a photo catalyst layer. Therefore, the heads can be rotated by the present invention, and the user can fix the heads rotated by a proper angle and use the device according to the present invention for a long time with a pose not burdening a wrist.

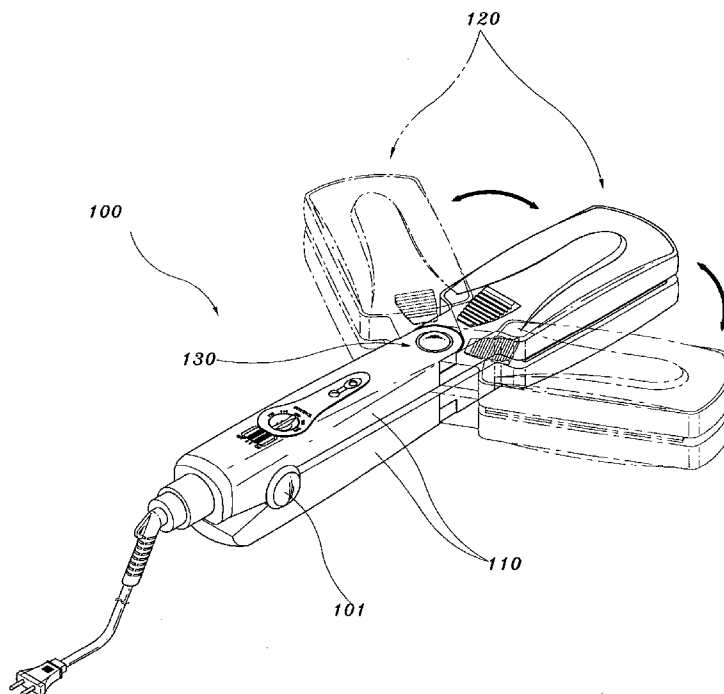

Fig1

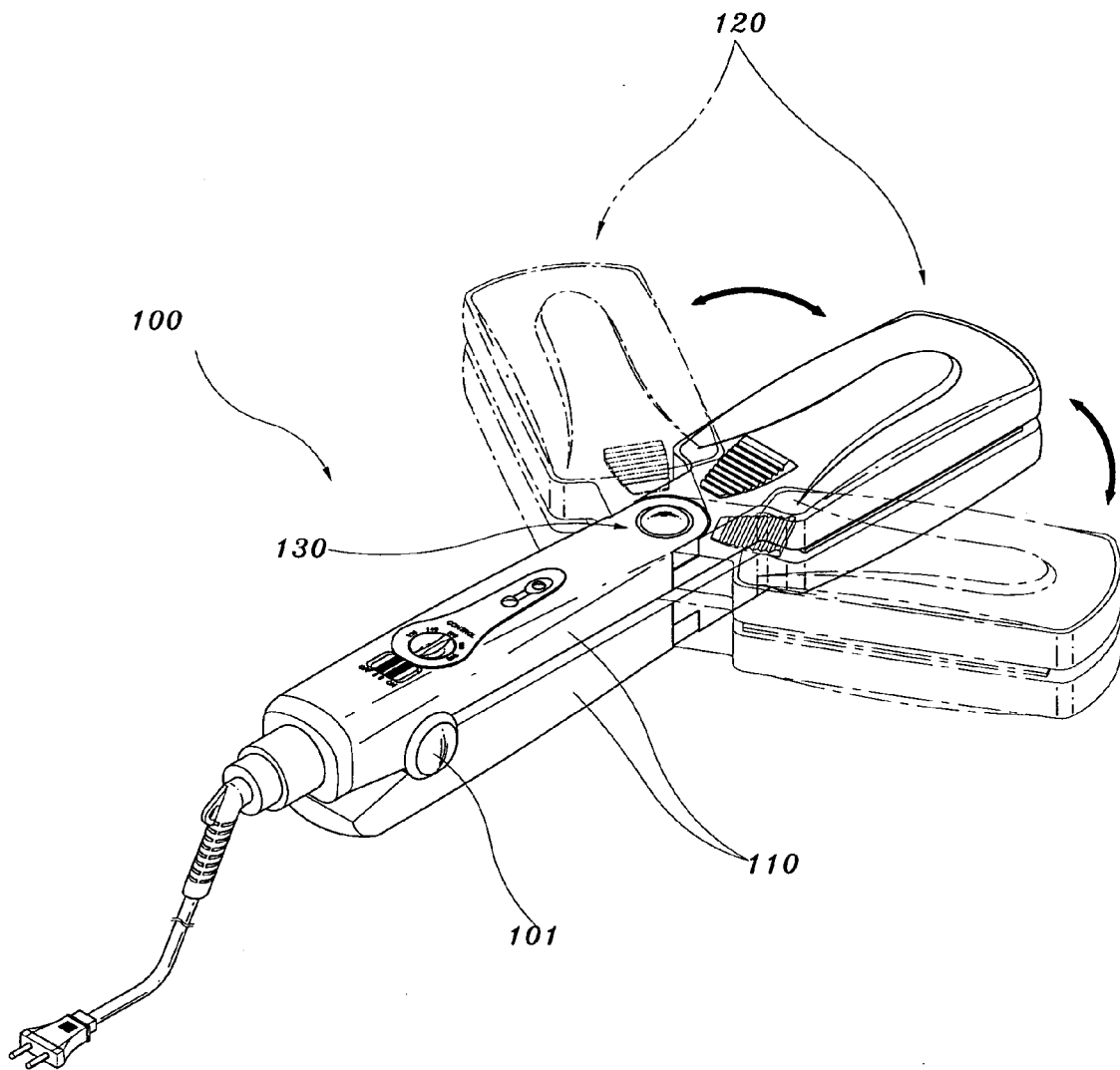

Fig2

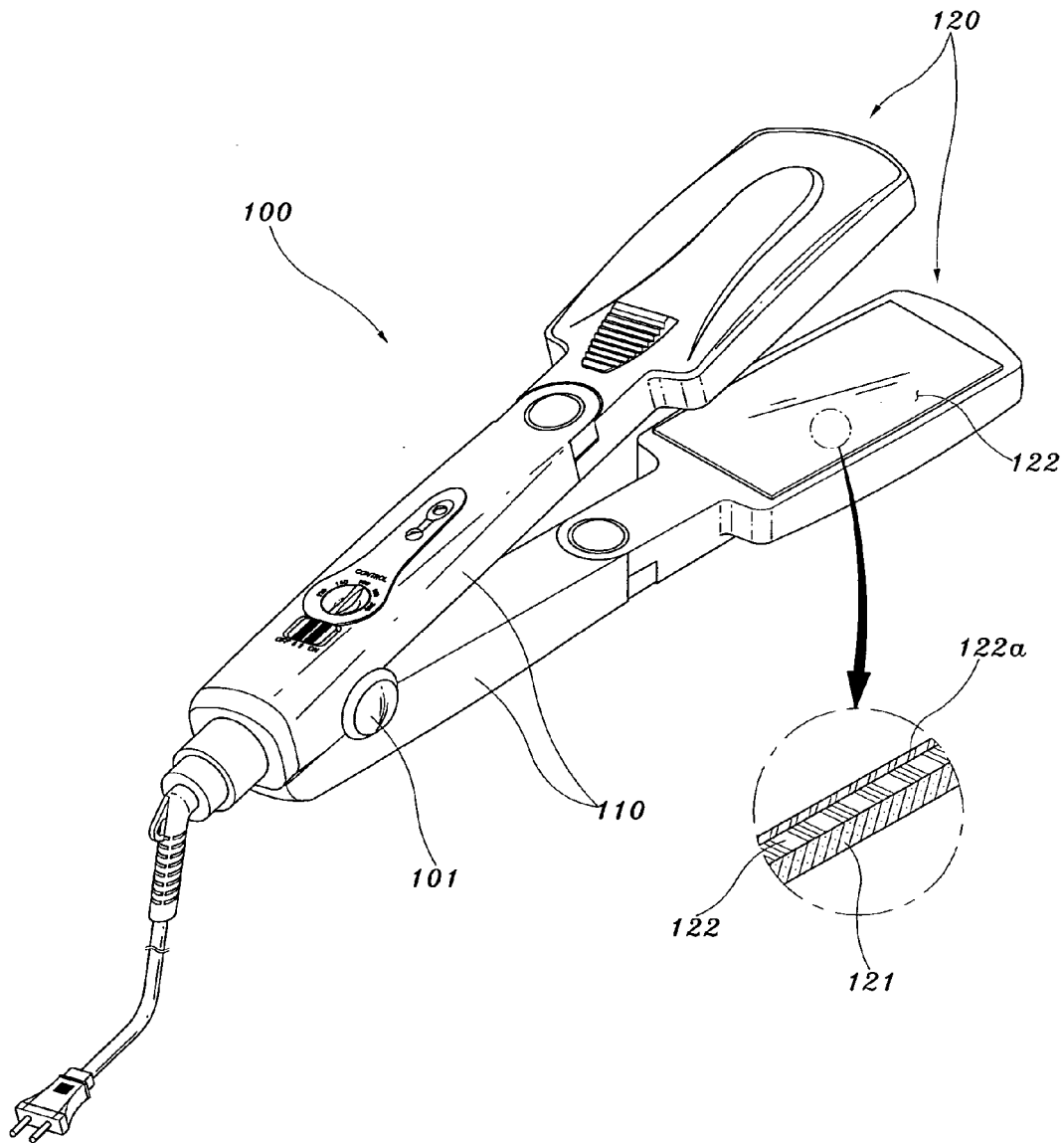

Fig3

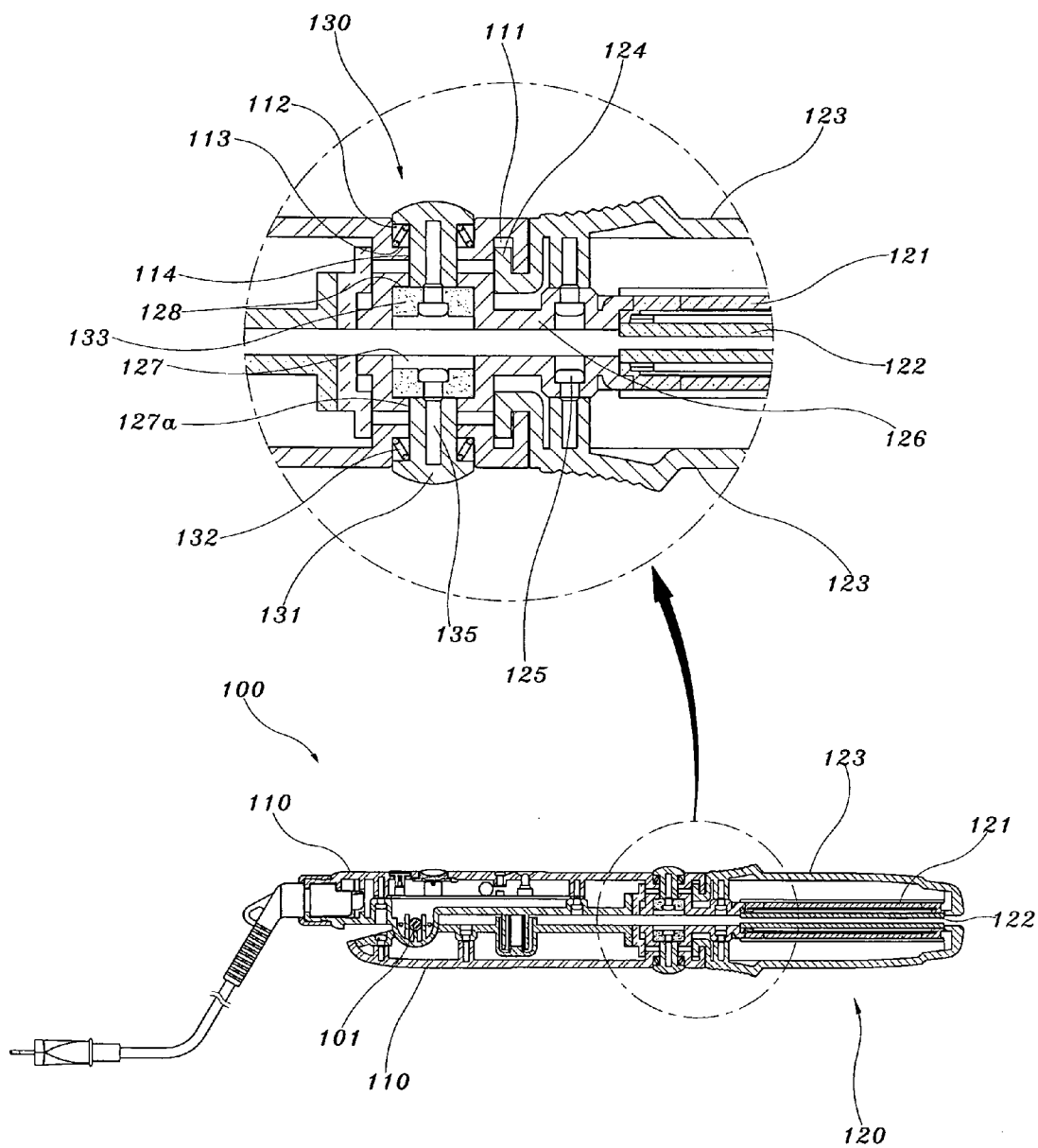

Fig5

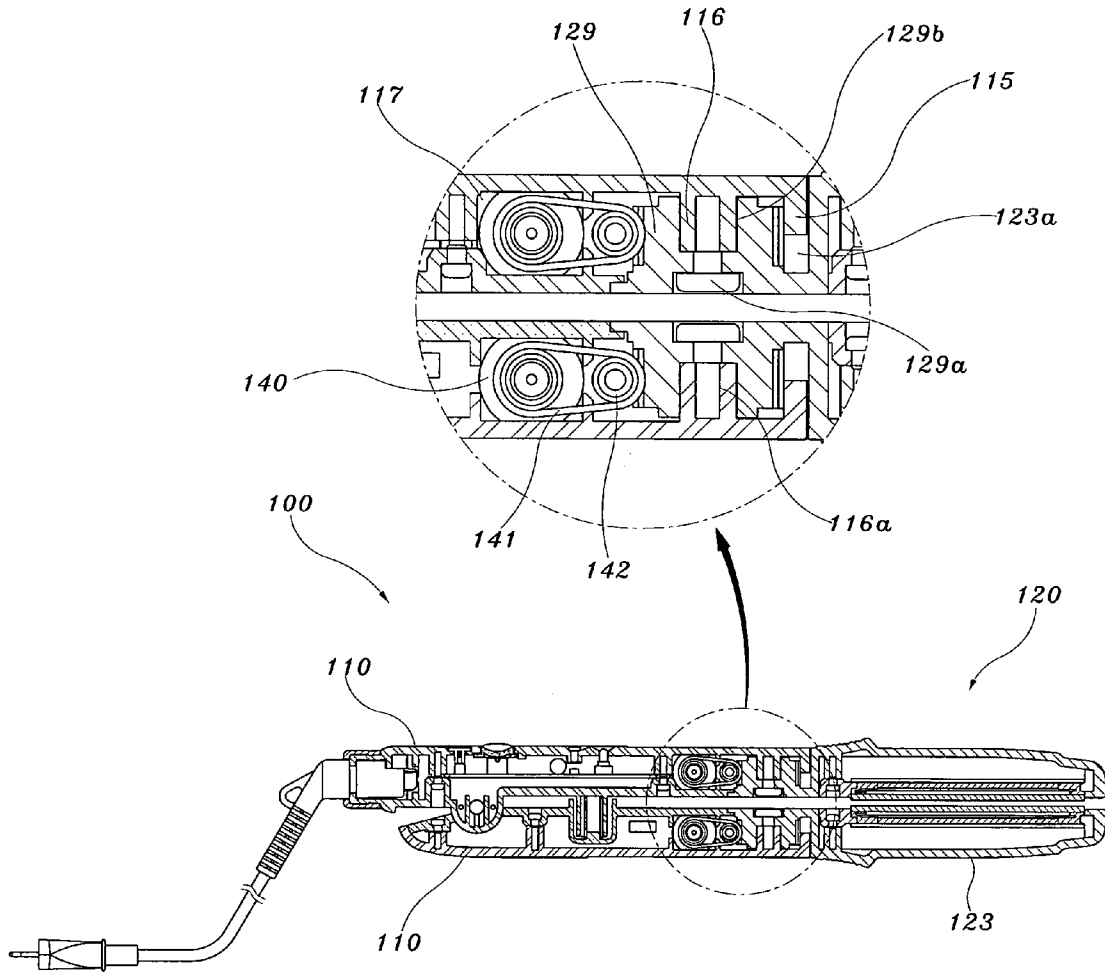

Fig6

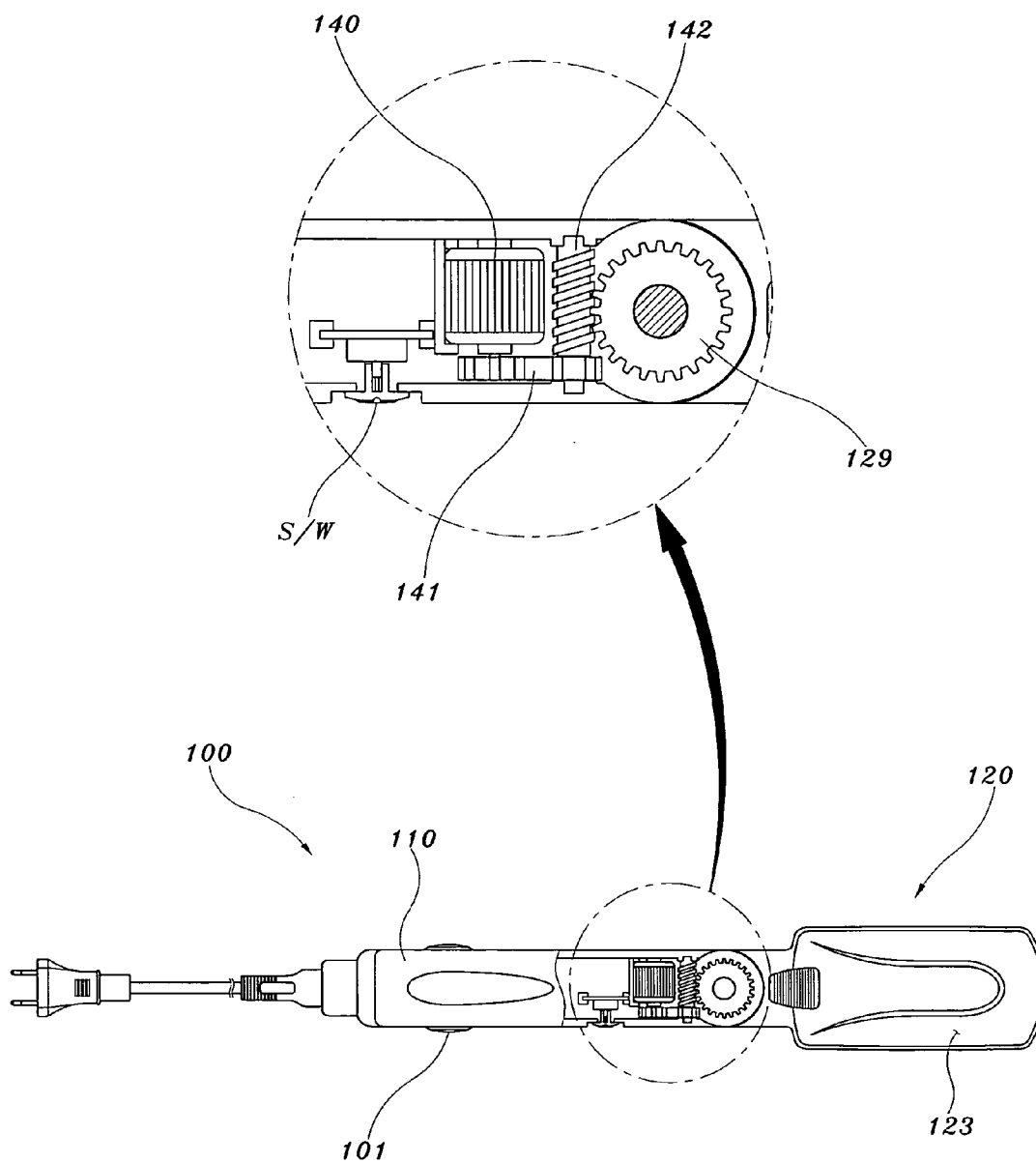
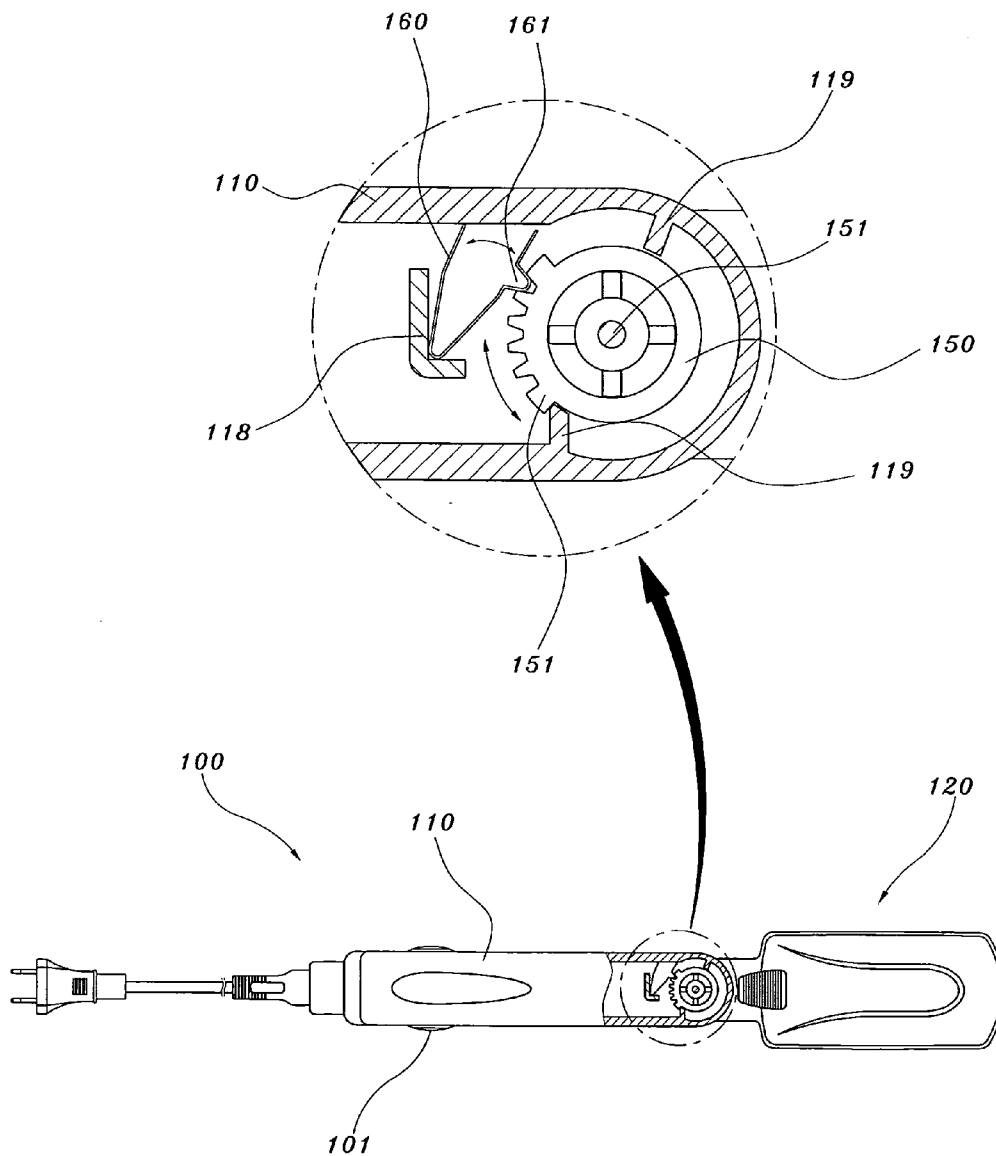

Fig7



DEVICE FOR CURLING HAIR

BACKGROUND OF THE INVENTION

[0001] 1. Field of the Invention

[0002] The present invention relates to a device for curling hair which is used for a hair dressing, more specifically the device for curling hair, in which a head thereof is configured to rotate and a user sets the head to rotate by an appropriate angle, so that the user can use the device for a long time with a pose not burdening a wrist of the user.

[0003] 2. Background of the Related Art

[0004] Generally, a hairstyle is one of important factors for a beauty of people, especially women, and is used as means for sufficiently showing one's aesthetic sense by frequently changing it according to a costume, time and place. As one's individuality may be judged by his or her hairstyle, an importance of the hairstyle increase more and more nowadays. Therefore, as well known, people try to various hairstyles for showing their aesthetic sense.

[0005] A hair curling device is used in a beauty shop as means for providing a change of the hairstyle, and conventionally comprises upper and lower grips folded or unfolded about a hinge, upper and lower heads connecting respectively to the upper and lower grips, and heating means generating heat by an electric power and installed in the heads. When the hair passes between the folded upper and lower heads, various hairstyles are made by the heat generated in the heads so that the hair curling device enables pursuing the beauty and expressing the individuality of the women as mentioned above.

[0006] In such conventional hair curling device, as the heads are connected to the grips as one body, the grips is held by one hand of the user and the hair is located between the unfolded heads with the hair being held by the other hand. Then, the heads are folded to contact with each other, are slowly moved as sweeping the hair downwardly with the hair being held between the heads, and thereby the hair is made a desired style by the heat generated in the heating means formed within the heads.

[0007] However, in the conventional hair curling device, since the heads are integrally connected to the grips in a straight line, the wrist of hand or an arm holding the hair curling device is excessively bent, while the hair is held by one hand and is located between the unfolded heads with the other hand holding the grips of the hair curling device. In addition, a portion of the hair adjacent to a head can not be properly located between the unfolded heads of the conventional hair curling device so that the hair is not curled entirely.

[0008] Further, when the user uses the hair curling device for many hours with such an uncomfortable pose, a pain in shoulder and muscle is caused.

SUMMARY OF THE INVENTION

[0009] The present invention is contemplated to solve the aforementioned problem, and it is an object of the present invention to provide a device for curling hair in which a grip and a head are formed separately and the head is configured to rotate toward either side by a desired angle about an end portion of the grip, so that it is avoidable to use the device

for a long time with a wrist of hand holding the grip being excessively bent, and thus a user curls his or her own hair easily and conveniently for a long time without a burden to the wrist.

[0010] According to one aspect of the present invention to accomplish the above object, the present invention provides a device for curling hair comprising: a pair of heads having a heating plate heated by an internal heating means; a pair of grips connected with the heads respectively, the grips being unfolded together with the heads about a hinge provided at one end thereof; and means for rotating the heads wherein a guide groove is formed at a bottom surface of the other end in each grip, receiving groove is formed at an upper surface of the other end in each grip, and each receiving groove has a step portion and a through hole at a center thereof, wherein an end of a cover in each head is bent to form a guide to be inserted into the guide groove of each grip, a connecting piece is coupled with each cover by bolt, and each connecting piece has a recess and an irregular portion formed at a bottom surface of the recess, and wherein an intermitting piece having an irregular portion formed at an upper surface thereof is accommodated in the recess of each connecting piece and is fastened to a button provided to each head by a bolt, a pushing part is provided between a bottom surface of each button and the step portion of each receiving groove supported by a spring, and each connecting piece is separated from each intermitting piece by pushing the each pushing part so as to allow each head to freely rotate.

[0011] In addition, According to the other aspect, the present invention provides a device for curling hair comprising: a pair of heads having a heating plate heated by an internal heating means; a pair of grips connected with the heads respectively, the grips being unfolded together with the heads about a hinge provided at one end thereof; and means for rotating the heads wherein a motor and a worm gear are accommodated in a receiving part of each grip, the motor is driven in both of a regular and a reverse direction and the worm gear is connected with the motor by a timing belt, a spur gear is formed integrally with one end of a cover in each head, and the spur gear is rotatably coupled to the other end of each grip by a bolt and is engaged with the worm gear.

BRIEF DESCRIPTION OF THE DRAWINGS

[0012] The features and advantages of the present invention will be more described specifically in the following description of preferred embodiments of the invention with reference to the accompanying drawings wherein:

[0013] **FIG. 1** is a perspective view showing a rotation of a head in a hair curling device according to the present invention;

[0014] **FIG. 2** is a perspective view showing an unfolding of a head in a hair curling device according to the present invention;

[0015] **FIG. 3** is a schematic sectional view showing a first embodiment of the present invention;

[0016] **FIG. 4** is a partial enlarged view and a partial exploded view of the first embodiment shown in **FIG. 3**;

[0017] **FIG. 5** is a schematic sectional view showing a second embodiment of the present invention;

[0018] FIG. 6 is a schematic sectional view showing a hair curling device according to FIG. 5; and

[0019] FIG. 7 is a schematic sectional view showing a third embodiment of the present invention.

DETAILED DESCRIPTION OF THE PREFERRED EMBODIMENT

[0020] Reference will now be made in detail to the first and second embodiment of the present invention, examples of which are illustrated in the accompanying drawings. In explaining the present invention, the same names and reference numerals will be given to the same components, and explanations in the same will be omitted.

First Embodiment

[0021] As shown in accompanying drawings, the present invention according to a first embodiment provides a device for curling hair which allows a head 120 to manually rotate by a predetermined angle so that a hand holding the hair curling device is not excessively bent and a user can take care of his or her hair with a comfortable pose.

[0022] First, explaining a general structure of the hair curling device 100, a pair of grips 110 unfolded respectively in upward and downward directions about a hinge 101 provided to one side thereof and a pair of heads 120 connected to the grips 110 are formed in the device 100. After unfolding the grips 110 together with the heads 120 about the hinge 101, the grips 110 are folded about the hinge 101 in order for the heads to be contacted with each other, locating the hair to be taken care of between the heads 120. Then, a heating plate 122 heated by heating means 121 in the heads 120 applies heat to the hair so that the user is enabled to change the hair into a desired style.

[0023] To accomplish the object of the present invention using the hair curling device 100 as above, the heads 120 accommodating the heating plates 122 heated by the heating means 121 are configured to be separated from the grips 110 and a pushing part 130 allowing the head 120 to rotate at one end of the grip 110 is installed so that the head 120 is detached from the grip 110 according to pushing the pushing part 130 and thus the user can freely rotate the head 120 in right and left sides.

[0024] As shown in the drawings, the grip 110 is formed to be separated from the head 120, and an end portion is bent to form an arc shaped guide groove 111 at a bottom surface thereof so that a rear ended guide 124 of the head 120 mentioned below is fitted into and guided by the groove.

[0025] Meanwhile, a receiving groove 112 is formed at an upper surface of one end in the grip 110, and a step portion 113 is integrally formed at a lower circumferential surface of the receiving groove 112. Such receiving groove 112 is to accommodate the pushing part 130, and the step portion 113 is means for supporting a spring 132 which provides elasticity to the pushing part 130. Additionally, a through hole 114 is formed to pass through a center of the receiving groove 112.

[0026] The head 120 is configured to be coupled with and rotate relative to the grip 110. The head 120 includes the heating means 121 generating heat by the electric power supply and received therein, the heating plate 122 which is

means for curling the hair heated by the heat from the heating means 121, and a cover 123 forming an outer appearance of the head 120. An end of the cover 123 is bent to form the guide 124, and this guide 124 is coupled with the guide groove 111 which is formed at the bottom surface of the grip 110 with an arc shape.

[0027] Accordingly, the guide 124 of the cover 123 is guided along the guide groove 111 of the grip 110 and makes the entire head 120 to rotate. This cover 123 is fastened to a connecting piece 126 by a bolt 125.

[0028] The connecting piece 126 is, as can be seen in FIG. 3 and FIG. 4 formed with a recess 127 having a through hole 127a at a bottom surface thereof, and an irregular portion 128 is formed on the bottom surface of the recess 127 so that this irregular portion 128 is intermittently connected with an irregular portion 134 of an intermitting piece 133.

[0029] The pushing part 130 is means for allowing the head 120 to rotate about the receiving groove 112 of the grip 110 or to keep being rotated. As shown in FIG. 4, in pushing part, a button 131 is coupled with the cylindrical intermitting piece 133 provided below by a blot 135, and a spring 132 is installed at a lower part of the button 131.

[0030] In this instance, the irregular portion 134 as shown is formed on an upper surface of the intermitting piece 133.

[0031] As shown in FIG. 3, a lower part of such pushing part 130 projects passing through the through hole 114 in the receiving groove 112 of the grip 110, and the intermitting piece 133 is located within the recess 127 of the connecting piece 126 which is provided below the receiving groove 112 and is fastened to the button 131 by the bolt 135. The spring 132 is elastically installed between the bottom surface of the button 131 and the step portion 113 a lower part of the receiving groove 112 of the grip 110, and the irregular portion 134 on the upper surface of the intermitting piece 133 coupled to the lower part of the button 131 is directly contacted with the irregular portion 128 formed on the bottom surface of the recess 127 of the connecting piece 126 for a constant coupling therebetween by elastic force constantly given to the button 131 in upward direction.

[0032] The grip 110, head 120 and pushing part 130 as explained above are made to be a pair opposite to each other, and thus the opposite grip 110/head 120 are unfolded rotating the hinge 101 at one end of the grips 110.

[0033] An operation of the first embodiment of the present invention will be described in detail as follows.

[0034] When the user tries to curl the hair in a rear of the head, it is necessary for the user to easily locate the hair near the head between the heads 120 opposite to each other by one hand with holding the unfolded grips 110 of the hair curling device 100 by the other hand. First, when the user pushed the button 131 of the pushing parts 130 formed at each grip 120, the button 131 pushes the intermitting piece 133 coupled to the lower part thereof downwardly, overcoming the elastic force of the spring 132 installed to the bottom surface thereof, so that the irregular portion 134 formed on the upper surface of the intermitting piece 133 is separated from the irregular portion 128 formed on the bottom surface of the connecting piece 126.

[0035] As such, as the irregular portion 134 of the intermitting piece 133 is separated from the irregular portion 128

of the connecting piece 126, the heads 120 can freely rotate. When the user releases the pushed button 131 of the pushing part 130 after rotating the heads 120 by a desired angle, the pushing part 130 moves upwardly by the elastic force of the spring 132 together with the intermitting piece 133 coupled thereto and the intermitting piece 133 comes in contact with the irregular portion 128 of the connecting piece 126 to be coupled with the connecting piece 126. Accordingly, as shown in FIG. 1, the heads 120 is fixed rotated by a proper angle determined by the user.

[0036] Therefore, if the heads 120 is rotated by the proper angle in a desired direction, the user can curls the hair more easily and conveniently without the burden to the wrist, comparing with curling the hair in a rear of the head by the heads 120 located in a straight line with the grips 110.

Second Embodiment

[0037] The heads 120 can be rotated by a regular and reverse directional drive of a motor 140, different from the heads 120 manually rotated in the first embodiment. Such second embodiment using the motor will explained as follow.

[0038] The second embodiment is characterized in that the motor 140 driven by a switch S/W and a worm gear 142 connected by a timing belt 141 are formed in the grip 110, a center of a spur gear 129 integrally connected to an end of the cover 123 is rotatably coupled to the end of the grip 110 by a bolt 129a and the spur gear 129 is engaged with the worm gear 142.

[0039] The end of the grip 110 according to the second embodiment is, as shown in FIG. 5 is formed to be the arch shape and is bent downwardly so as to form a guide 115, a projection 116 for supporting the spur gear 129 projects integrally within the grip 110, and a groove 116a is formed at a center of the projection 116.

[0040] In addition, a receiving part 117 is formed in the grip 110 to accommodate the motor 140 and the worm gear 142 engaged with the spur gear 129.

[0041] Meanwhile, the cover 123 is formed to cover the head 120 connected to the end of the grip 110, the spur gear 129 is formed integrally with the end of the cover 123, and a guide groove 123a which the guide 115 of the grip 110 is inserted into and guided by is formed between the spur gear 129 and the cover 123.

[0042] Furthermore, a recess 129b which the projection 116 is inserted into in order to support the spur gear is formed at the center of the spur gear 129 and a bolt 129a passing through the spur gear 129 is fastened to a groove 116a formed at a center of the projection 116, while the projection 116 is inserted into the recess 129b, so that the entire head 120 can rotate in both of right and left side according to a rotation of the spur gear 129.

[0043] In this instance, as mentioned above, means for driving the spur gear 129 is the motor 140 and worm gear 142 received within the receiving part 117. These motor 140 and worm gear 142 are, as shown in the drawings connected with each other by the timing belt 141, an operation of the motor 140 is controlled to be driven in the regular and reverse direction by the switch S/W, and the worm gear 142 is engaged with the spur gear 129.

Third Embodiment

[0044] Accompanying FIG. 7 illustrates still another embodiment of the present invention. A rotation part 150 is formed integrally with a shaft 151 at a coupling part of the head 120 and the grip 110 and is configured to rotate together with the head 120, and an irregular portion 151 is formed on a proper section of a circumferential surface of the rotation part 150. A plate spring 160 is elastically supported by a supporter 151 disposed in the end portion of the grip 110 and has a projection 161 formed at one side thereof so as to coupled to or separated from the irregular portion 151 of the rotation part 150. A stopper 119 restricting the rotation part 150 to rotate over a predetermined angle is spaced apart from the rotation part 150 in a circumferential direction and is formed integrally in the end portion of the grip 110.

[0045] Therefore, according to the third embodiment, when the user grips the heads 120 of the hair curling device 100 and applies the force thereto in order to rotate the heads 120 by desired angle, the rotation parts 150 are rotated overcoming the tension of the plate springs 160, which restrict the rotation of the rotation parts 150 by being coupled to the irregular portions 151, and simultaneously the heads 120 are also rotated.

[0046] After the heads are rotated by the desired angle, if the force applied to the heads 120 is released, the projections 161 of the plate springs 160 are inserted into grooves formed in the irregular portions 151 and restrict the heads 120 to rotate more so that the user can use the hair curling device 100 with the heads 120 rotated and fixed by the desired angle.

[0047] Meanwhile, in the first and second embodiment of the present invention, a layer 122a made of a photo catalyst is coated on an surface of the heating plate 122 which is inserted into the head 120 of the hair curling device 100 and is heated by the heating means 121 so as to curl the hair of the user.

[0048] Such a photo catalyst is used to designate a catalyst accelerating a photoreaction, and is ceramic material, usually TiO₂ functioning by absorbing light. Once the photo catalyst absorbs ultraviolet rays, electrons and holes, are formed on a surface thereof, these activated species (electron, hole) decompose most of harmful material so as to obtain a contamination prevention, an air purification, a sterilization, and an deodorization. In Addition, the photo catalyst is water-soluble and harmless to human body, and almost permanent once coated so that it is widely used in various fields.

[0049] The present invention forms the photo catalyst layer 122a on the heating plate 122 directly contacting with the hair, so that if harmful material is contained in the hair or the odor penetrates the hair, such harmful material and odor are removed during the curling.

[0050] An operation of the second embodiment of the present invention will be described in detail as follows.

[0051] Similar to the first embodiment, when the user tries to curl the hair in a rear of the head, the user needs to rotate the heads 120 by the desired angle in order not to burden the wrist holding the grip 110. First, when the user operates the switch S/W, the timing belt 141 connected with the motor

140 rotates the worm gear 142 by the regular and reverse directional drive of the motor 140 receiving a signal from the switch S/W, and simultaneously rotates the spur gear 129 engaged with the worm gear 142, so that the heads 120 connected integrally with the spur gear 129 are rotated in the right and left directions while the switch S/W is pushed. When the heads 120 are rotated to the proper angle that the user wishes, the heads 120 are fixed rotated by the proper angle determined by the user by releasing the switch S/W.

[0052] Then, the user unfolds the heads 120 bent by the desired angle relative to the grips 110 about the hinge 101 at the end of the grips 110, locates his or her hair to be curled between the heating plates 122 of the heads 120, and then curls the hair by contacting the heads 120 with each other. As the user should wait for an appropriated time period holding the grips 110 in order to have the hair fully curled, the user can curl the hair for such time period with a comfortable and natural pose in which the wrist is not excessively bent by the present invention.

[0053] The advantages of the present invention are summarized as follows.

[0054] When the user tries to curl his or her hair by using the hair curling device which has the conventional heads coupled integrally with the grips 110 in a straight line, it is difficult for the user to locate the hair in the rear of the head between the heads. In addition, as the hand or arm holding the grips should be excessively twisted for a long time to the locate the heads in a proper position, this causes the fatigue, the unstable pose, and the pain of the wrist or arm. However, in case of the present invention, as the heads can rotate by the proper angle in the right or left side relative to the grips, the user can easily and conveniently curl the hair difficult to be curled, that is the hair in the rear of the head with the comfortable pose not burdening the body for a long time.

[0055] Additionally, in the present invention, as the photo catalyst layer is coated on the heating plate of the hair curling device, this layer decomposes various harmful material contained in the hair and removes the odor of the hair so that the user has the healthy and clean hair constantly.

[0056] Although a number of embodiment have described in the above specification, it should be apparent that the present invention could be embodied in many other specific mode included within the sprit and scope of the present invention. Thus, the present embodiments should be considered as illustrative, and the present invention could be modified within the scope of claims and the equivalent thereof.

What is claimed is:

1. A device for curling hair comprising:

a pair of heads having a heating plate heated by an internal heating means;

a pair of grips connected with the heads respectively, the grips being unfolded together with the heads about a hinge provided at one end thereof; and

means for rotating the heads wherein a guide groove is formed at a bottom surface of the other end in each grip,

receiving groove is formed at an upper surface of the other end in each grip, and each receiving groove has a step portion and a through hole at a center thereof,

wherein an end of a cover in each head is bent to form a guide to be inserted into the guide groove of each grip, a connecting piece is coupled with each cover by bolt, and each connecting piece has a recess and an irregular portion formed at a bottom surface of the recess, and

wherein an intermitting piece having an irregular portion formed at an upper surface thereof is accommodated in the recess of each connecting piece and is fastened to a button provided to each head by a bolt, a pushing part is provided between a bottom surface of each button and the step portion of each receiving groove supported by a spring, and each connecting piece is separated from each intermitting piece by pushing the each pushing part so as to allow each head to freely rotate.

2. A device for curling hair comprising:

a pair of heads having a heating plate heated by an internal heating means;

a pair of grips connected with the heads respectively, the grips being unfolded together with the heads about a hinge provided at one end thereof; and

means for rotating the heads wherein a motor and a worm gear are accommodated in a receiving part of each grip, the motor is driven in both of a regular and a reverse direction and the worm gear is connected with the motor by a timing belt, a spur gear is formed integrally with one end of a cover in each head, and the spur gear is rotatably coupled to the other end of each grip by a bolt and is engaged with the worm gear.

3. The device according to claim 1 or claim 2, wherein the heating plate is coated with a photo catalyst layer.

4. A device for curling hair comprising:

a pair of heads having a heating plate heated by an internal heating means;

a pair of grips connected with the heads respectively, the grips being unfolded together with the heads about a hinge provided at one end thereof; and

means for rotating the heads wherein a rotation part is formed integrally with a shaft at a coupling part of each head and grip and is configured to rotate together with each head, and an irregular portion is formed on a proper section of a circumferential surface of each rotation part, wherein a plate spring is elastically supported by a supporter disposed in the end portion of each grip and has a projection formed at one side thereof so as to coupled to or separated from the irregular portion of each rotation part, and wherein a stopper restricting the rotation part to rotate over a predetermined angle is spaced apart from the rotation part in a circumferential direction and is formed integrally in the end portion of each grip.

* * * * *