

(12) STANDARD PATENT
(19) AUSTRALIAN PATENT OFFICE

(11) Application No. **AU 2006282584 B2**

(54) Title
Bottle

(51) International Patent Classification(s)
B65D 1/02 (2006.01)

(21) Application No: **2006282584**

(22) Date of Filing: **2006.07.24**

(87) WIPO No: **WO07/023630**

(30) Priority Data

(31) Number
2005-241140

(32) Date
2005.08.23

(33) Country
JP

(43) Publication Date: **2007.03.01**

(44) Accepted Journal Date: **2011.09.29**

(71) Applicant(s)
Yoshino Kogyosho Co., Ltd.

(72) Inventor(s)
Iizuka, Takao; Imai, Hiroaki; Tanaka, Toshimasa

(74) Agent / Attorney
Phillips Ormonde Fitzpatrick, 367 Collins Street, Melbourne, VIC, 3000

(56) Related Art
US 4993566

(12) 特許協力条約に基づいて公開された国際出願

(19) 世界知的所有権機関
国際事務局



(43) 国際公開日
2007年3月1日 (01.03.2007)

PCT

(10) 国際公開番号
WO 2007/023630 A1

- (51) 国際特許分類:
B65D 1/02 (2006.01)
- (21) 国際出願番号: PCT/JP2006/314557
- (22) 国際出願日: 2006年7月24日 (24.07.2006)
- (25) 国際出願の言語: 日本語
- (26) 国際公開の言語: 日本語
- (30) 優先権データ:
特願2005-241140 2005年8月23日 (23.08.2005) JP
- (71) 出願人 (米国を除く全ての指定国について): 株式会社吉野工業所 (YOSHINO KOGYOSYO CO., LTD.) [JP/JP]; 〒1368531 東京都江東区大島三丁目2番6号 Tokyo (JP).
- (72) 発明者; および
- (75) 発明者/出願人 (米国についてのみ): 田中 敏正 (TANAKA, Toshimasa) [JP/JP]; 〒1368531 東京都江東区大島三丁目2番6号 株式会社吉野工業所内 Tokyo (JP).
- (74) 代理人: 志賀 正武, 外 (SHIGA, Masatake et al.); 〒1048453 東京都中央区八重洲2丁目3番1号 Tokyo (JP).
- (81) 指定国 (表示のない限り、全ての種類の国内保護が可能): AE, AG, AL, AM, AT, AU, AZ, BA, BB, BG, BR, BW, BY, BZ, CA, CH, CN, CO, CR, CU, CZ, DE, DK, DM, DZ, EC, EE, EG, ES, FI, GB, GD, GE, GH, GM, HN, HR, HU, ID, IL, IN, IS, KE, KG, KM, KN, KP, KR, KZ, LA, LC, LK, LR, LS, LT, LU, LV, LY, MA, MD, MG, MK, MN, MW, MX, MZ, NA, NG, NI, NO, NZ, OM, PG, PH,

[続葉有]

(54) Title: BOTTLE

(54) 発明の名称: ボトル

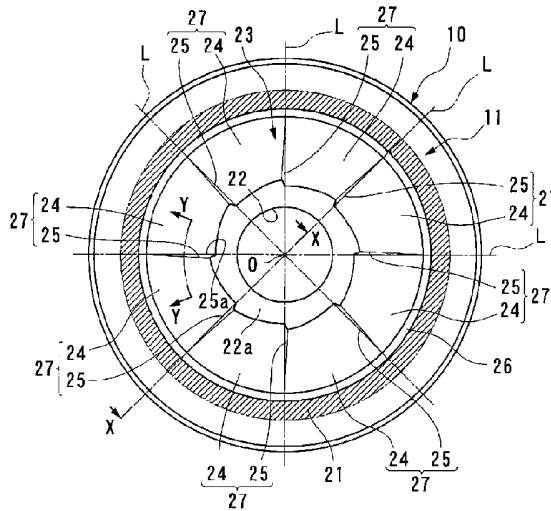

(57) Abstract: A bottle, comprising a ground-contact part formed at the bottom part outer peripheral edge thereof, a center recessed part formed on the inside of the ground-contact part and recessed toward the inside of the bottle, an annular wall part formed between the ground-contact part and the center recessed part and raised so as to be gradually raised from the ground-contact part to the center recessed part, and a plurality of ribs formed on the annular wall part parallel with each other in the circumferential direction of the bottom part, and projected to the inside of the bottle. Each of the ribs comprises a rise wall part rising to the inside of the bottle and a tilted wall part tilted from the upper edge of the rise wall part to the lower edge of the rise wall part of the adjacent rib. The rise wall part is tilted sharper than the tilted wall part.

(57) 要約: このボトルは、底部の外周縁に設けられた接地部と、前記接地部の内側に設けられ、前記ボトルの内部に向けて凹む中央凹部と、前記接地部と前記中央凹部との間に設けられ、前記接地部から前記中央凹部に向けて徐々に高くなるように傾斜する環状壁部と、前記環状壁部に前記底部の周方向に並んで設けられ、前記ボトルの内部に向

[続葉有]



WO 2007/023630 A1



PL, PT, RO, RS, RU, SC, SD, SE, SG, SK, SL, SM, SY, TJ, TM, TN, TR, TT, TZ, UA, UG, US, UZ, VC, VN, ZA, ZM, ZW.

OAPI (BF, BJ, CF, CG, CI, CM, GA, GN, GQ, GW, ML, MR, NE, SN, TD, TG).

(84) 指定国 (表示のない限り、全ての種類の広域保護が可能): ARIPO (BW, GH, GM, KE, LS, MW, MZ, NA, SD, SL, SZ, TZ, UG, ZM, ZW), ユーラシア (AM, AZ, BY, KG, KZ, MD, RU, TJ, TM), ヨーロッパ (AT, BE, BG, CH, CY, CZ, DE, DK, EE, ES, FI, FR, GB, GR, HU, IE, IS, IT, LT, LU, LV, MC, NL, PL, PT, RO, SE, SI, SK, TR),

添付公開書類:

— 国際調査報告書

2文字コード及び他の略語については、定期発行される各PCTガゼットの巻頭に掲載されている「コードと略語のガイダンスノート」を参照。

けて突出する複数のリブとを備える。前記リブは、前記ボトルの内部に向けて立ち上がる立ち上がり壁部と、前記立ち上がり壁部の上縁から隣のリブの立ち上がり壁部の下縁に向けて傾斜する傾斜壁部とを備える。前記立ち上がり壁部は、前記傾斜壁部よりも急峻に傾斜している。

DESCRIPTION

BOTTLE

TECHNICAL FIELD

5 [0001] The present invention relates to a bottle into which, for example, a high-temperature liquid is filled.

The present application is to claims the right of priority on the basis of Japanese Patent Application No. 2005-241140 filed on August 23, 2005, with the description cited
10 herein.

BACKGROUND ART OF THE INVENTION

[0002] In general, this type of bottle is made from a synthetic resin such as polyethylene terephthalate and produced, for
15 example, by blow molding. In recent years, the energy necessary for re-melting on recycling have been reduced to cope with environmental problems or materials have been used in a smaller quantity to save material costs. As a result, the bottle in itself has been made lighter in weight.

20 [0003] However, a bottle made lighter in weight decreases the rigidity. Therefore, for example, the bottom thereof is softened by heat resulting from a high-temperature liquid filled into the bottle. When the weight of the liquid acts on the thus softened bottom, a base portion installed on the outer
25 circumference brim at the bottom of the bottle is deformed so

as to swell toward the outside of the bottle, which may inhibit stability when the bottle is set upright, that is, uprightness. Alternatively, when a bottle, into which a high-temperature liquid is filled, is heated in order to impart sterilization, the internal pressure of the bottle is increased, thereby the base portion at the bottom of the bottle is deformed so as to swell outwardly, which may inhibit the uprightness of the bottle, as described above.

[0004] In order to solve the above problem, for example, the technology disclosed in Patent Document 1 given below may be adopted. Specifically, a plurality of hollow ribs protruding outside the bottle to extend in a radial direction are formed so as to be spaced at a predetermined interval in a circumferential direction at an annular recess located between the base portion of a bottle and a central recess installed at the center of the bottom of the bottle. Thereby, the compressive strength of the bottom of the bottle is increased.

PATENT DOCUMENT 1: Japanese Unexamined Patent Application,
First Publication No. 2002-308245

The above discussion of background art is included to explain the context of the present invention. It is not to be taken as an admission that any of the documents or other material referred to was published, known or part of the common general knowledge in Australia at the priority date of any one of the claims of this specification.

DETAILED DESCRIPTION OF THE INVENTION

PROBLEMS TO BE SOLVED BY THE INVENTION

[0005] However, in the above-described bottle, since stress tends to concentrate on the outer circumference brim of an annular recess continuing to a joint between adjacent hollow ribs, there is room for improvement in compressive strength of the base portion continuing to the outer circumference brim of the annular recess.

Further, since hollow ribs are formed to make the configuration of the annular recess complicated, there is a case where the inside of a bottle before a content is filled is insufficiently cleaned or a cleaning liquid is not easily and assuredly discharged from the inside of the bottle. As a result, there may be a decrease in the handling property of the bottle.

[0006] The present invention has been made in view of the above situation, a desirable outcome of which is to provide a bottle having a sufficient compressive strength at the bottom thereof without decreasing the handling property even when the bottle is made lighter in weight.

SUMMARY OF THE INVENTION

Thus, the present invention provides a bottle comprising:

a base portion installed on the outer circumference brim of the a bottom of the bottle;

a central recess installed inside the base portion and recessed toward the inside of the bottle;

an annular wall portion installed between the base portion and the central recess and inclined so as to elevate gradually from the base portion to the central recess; and

a plurality of ribs installed side by side at the annular wall portion in the circumferential direction of the bottom of the bottle and protruding toward the inside of the bottle; wherein

the ribs are provided with a rising wall portion rising toward the inside of the bottle and an inclined wall portion inclined from the upper brim of the rising wall portion toward the lower brim of the rising wall portion of an adjacent rib, and

the rising wall portion is inclined more steeply than the inclined wall portion. when the bottom of the bottle is viewed from the cross section along the circumferential direction, an angle θ_1 made by an outer surface of the rising wall portion and an outer surface of the base portion is 45 to 90 degrees, and an angle θ_2 made by an outer surface of the inclined wall portion and an outer surface of the base portion is 5 to 45 degrees.

[0007] The bottle of the present invention is provided with a base portion installed at the outer circumference brim of the bottom of the bottle, a central recess installed inside the base portion and recessed toward the inside of the

bottle, an annular wall portion installed between the base portion and the central recess and inclined so as to elevate gradually from the base portion to the central recess and a plurality of ribs installed side by side at the annular wall portion in the circumferential direction of the bottom and protruding toward the inside of the

bottle. The rib is provided with a rising wall portion which rises toward the inside of the bottle and an inclined wall portion which is inclined from the upper brim of the rising wall portion to the lower brim of the rising wall portion of an adjacent rib,
5 in which the rising wall portion is inclined more steeply than the inclined wall portion.

[0008] According to the present invention, since a plurality of ribs having an inclined wall portion and a rising wall portion, which is steeper than the inclined wall portion, are formed at
10 an annular wall portion on the bottom of the bottle, an increased internal pressure of the bottle will disperse a load acting on a joint between the ridge of each rib, that is, an inclined wall portion of each rib and the rising wall portion from the joint to the inclined wall portion. Further, even when a force is
15 exerted which allows the inclined wall portion to move outside the bottle, with an edge portion opposite to the joint of the inclined wall portion being used as a supporting point, the rising wall portion acts against the force, thereby the inclined wall portion is not deformed so as to move outside the bottle.
20 Therefore, even if there is an increase in internal pressure of the bottle, it is possible to prevent stress from concentrating on a specific site at the outer circumference brim of the annular wall portion. As a result, it is possible to improve the compressive strength of the bottom of the bottle
25 and also prevent the base portion continuing to the outer

circumference brim of the annular wall portion from being deformed so as to swell outside.

[0009] Further, since the rib has an inclined wall portion, the annular wall portion is not complicated in configuration. Therefore, the inside of the bottle can be sufficiently cleaned before a liquid or the like is filled therein. Still further, since a cleaning liquid can easily flow along the inclined wall portion, the cleaning liquid can be easily discharged from the bottle to prevent a decrease in the handling property of the bottle.

[0010] In the bottle of the present invention, when the bottom is viewed from below in the direction of the central axis line of the bottle, the upper brim of the rising wall portion may be inclined to a radial direction of the bottom.

Even when a force is exerted which allows an inclined wall portion to move outside the bottle, with an edge portion opposite to the joint of the inclined portion being used as a supporting point due to the elevated internal pressure of the bottle, the inclined wall portion is deformed so as to cover a rising wall portion. Then, the rising wall portion stops the force, thereby preventing a rib from being expanded in a circumferential direction and deformed so as to be crushed. Therefore, it is possible to further improve the compressive strength of the bottle.

ADVANTAGEOUS EFFECTS OF THE INVENTION

[0011] The present invention is able to make a bottle lighter in weight without decreasing the handling property and also impart a sufficient compressive strength to the bottom of the bottle.

BRIEF DESCRIPTION OF THE DRAWINGS

[0012] FIG. 1 is a schematic diagram illustrating Embodiment 1 of the bottle of the present invention.

FIG. 2 is a view for illustrating Embodiment 1 of the bottle of the present invention and shows a plan view when the bottom of the bottle given in FIG. 1 is viewed below.

FIG. 3 is a view for illustrating Embodiment 1 of the bottle of the present invention and a cross sectional view of the bottle cut along the line X-X given in FIG. 2.

FIG. 4 is a view for illustrating Embodiment 1 of the 20 bottle of the present invention and a cross sectional view of the bottle cut along the line Y-Y given in FIG. 2.

FIG. 5 is a view for illustrating Embodiment 2 of the bottle of the present invention and a plan view illustrating the bottom of the bottle.

DESCRIPTION OF THE REFERENCE SYMBOLS

[0013] 10, 30: BOTTLE

11: BOTTOM

21: BASE PORTION

5 22: CENTRAL RECESS

23: ANNULAR WALL PORTION

24: INCLINED WALL PORTION

25, 31: RISING WALL PORTION

27: RIB

10 O: CENTRAL AXIS LINE

BEST MODE FOR CARRYING OUT THE INVENTION

[0014] Hereinafter, an explanation will be given for Embodiment 1 of the present invention by referring to the drawings.

15 As illustrated in FIG. 1, the bottle 10 of the present embodiment is provided with a heel portion 12, a body portion 13, a shoulder portion 14 and a mouth portion 15. The bottle 10 is made with a synthetic resin such as polyethylene terephthalate and produced by, for example, blow molding. The

20 heel portion 12 is provided with a bottom 11. The body portion 13 is installed to be continued to the upper edge portion of the heel portion 12. The shoulder portion 14 is installed to be continued to the upper edge portion of the body portion 13 and gradually reduced in diameter along the upward direction.

25 The mouth portion 15 is installed to be continued to the upper

edge portion of the shoulder portion 14 and extended upwardly. The bottom 11, heel portion 12, body portion 13, shoulder portion 14 and mouth portion 15 are formed in an integrated manner along a predetermined axial line. Hereinafter, the axial line is
5 given as a central axis line O. A cross section perpendicular to the central axis line O of the bottle 10 is substantially in a circular shape. A male thread portion 15a is made at the mouth portion 15, and a cap (not illustrated) is screwed on at the male thread portion 15a.

10 [0015] A plurality of panel portions 13a are installed at the body portion 13 so as to be spaced at an equal interval along the circumferential direction of the body portion 13. Each of the panel portions 13a is formed so as to be recessed internally in a radial direction of the body portion 13. A column portion
15 13b extending toward the central axis line O is formed between the adjacent panel portions 13a. The panel portion 13a and the column portion 13b are arranged alternately along the circumferential direction of the body portion 13. The panel portion 13a is formed along a full length excluding the upper
20 edge portion 13c and the lower edge portion 13d in the direction of the central axis line O of the body portion 13. The panel portion 13a and the column portion 13b are formed with six pieces each.

[0016] An annular recess groove 16 is formed at a joint between
25 the heel portion 12 and the body portion 13 all along the

circumference in the circumferential direction of the body portion 13, and an annular recess groove 17 is formed at a joint between the body portion 13 and the shoulder portion 14 all along the circumference in the circumferential direction of the body portion 13.

As illustrated in FIG. 2 and FIG. 3, the bottom 11 is provided with a base portion 21, a central recess 22, an annular wall portion 23, and a plurality of ribs 27. The base portion 21 is installed on the outer circumference brim of the bottom 11, and touches the ground when the bottle 10 is set upright, with the mouth portion 15 kept above the base portion 21. The central recess 22 is installed on the inside of the base portion 21 and recessed toward the inside of the bottle 10. The annular wall portion 23 is installed between the base portion 21 and the central recess 22 and inclined so as to elevate gradually from the base portion 21 to the central recess 22.

[0017] A plurality of ribs 27 are installed side by side in the circumferential direction of the bottom 11 and protruding toward the inside of the bottle 10. Each of the ribs 27 is provided with a rising wall portion 25 and an inclined wall portion 24. The rising wall portion 25 rises steeply toward the inside of the bottle 10. The inclined wall portion 24 rises gently toward the inside of the bottle 10. The rising wall portion 25 is steeper than the inclined wall portion 24. It is noted that the number of ribs 27 is preferably from 4 to 16.

[0018] When the bottom 11 is viewed in the direction of the central axis line 0 from the outside of the bottle 10, the inclined wall portion 24 is formed in a circular arc shape at which the length along the circumferential direction of the bottom 11 is made longer as it moves closer to the base portion 21, in other words, a fan shape. The rising wall portion 25 is formed in a triangular shape so as to be tapered as it comes closer to the base portion 21, when the bottom 11 is also viewed in the direction of the central axis line 0 outside of the bottle 10. The inclined wall portions 24 are all formed in the same shape and the rising wall portions 25 are also all formed in the same shape. The inclined wall portion 24 and the rising wall portion 25 are alternately arranged in the circumferential direction of the bottom 11. Further, the circumferential face 22a of the central recess 22 is formed in a ratchet shape.

[0019] As illustrated in FIG. 3, when a face at which the heel portion 12 is cut along the central axis line 0 is viewed, the inclined wall portion 24 is inclined from the base portion 21 to the central recess 22 and also curved so as to be recessed toward the inside of the bottle 10. Further, as illustrated in FIG. 4, when a face at which the rib 27 is cut along the circumferential direction is viewed, the inclined wall portion 24 is formed in a flat-face shape and inclined from the lower brim of the rising wall portion 25 of an adjacent rib 27 toward the upper brim 25a of the rising wall portion 25 to give the

rib 27 in combination with itself.

[0020] Further, the edge portion of the inclined wall portion 24 located inside the bottom 11 in a radial direction and the edge portion of the rising wall portion 25 located inside in
5 the radial direction are made steeper along the central recess 22, smoothly continuing to the circumferential face 22a of the central recess 22.

[0021] As illustrated in FIG. 2, when the rib 27 is viewed from below in the direction of the central axis line O, the upper
10 brim 25a of the rising wall portion 26 is extended in a direction coincident with a radial direction of the bottom 11 of the bottle 10. In other words, the upper brim 26a of the rising wall portion 25 is extended in a direction coincident with a direction that a line L is extended which connects a point at which the rising
15 wall portion 25 is in contact with the base portion 21 with the center of the bottle 10 (central axis line O).

[0022] Further, as illustrated in FIG. 4, when the bottom 11 is viewed from the cross section along the circumferential direction, an angle θ_1 made by the outer surface 25b of the rising
20 wall portion 25 and the outer surface 21a of the base portion 21 is set to be in a range of 45 degrees to 90 degrees and preferably in a range of 60 degrees to 75 degrees. Further, an angle θ_2 made by the outer surface 24a of the inclined wall portion 24 and the outer surface 21a of the base portion 21 is
25 set to be in a range of 5 degrees to 45 degrees and preferably

in a range of 15 degrees to 30 degrees.

[0023] Further, as illustrated in FIG. 3, a step portion 26 is formed inside the base portion 21 so as to be recessed toward the inside of the bottle 10. The edge portion of the inclined wall portion 24 located outside the bottom 11 in the radial direction and the edge portion of the rising wall portion 25 located outside in the radial direction continue to the base portion 21 via the step portion 26. As illustrated in FIG. 2, the inner surface of the bottom 11 is formed along the outer surface of the bottom 11, and the thickness of the bottom 11 is equal throughout.

[0024] As described so far, according to the bottle 10 of the present embodiment, a plurality of ribs 27 provided with an inclined wall portion 24 and a rising wall portion 25 steeper than the inclined wall portion 24 are formed at the annular wall portion 23. Therefore, an increased internal pressure of the bottle 10 will disperse a load acting on a joint between the ridge of each rib 27, that is, an inclined wall portion 24 of each rib 27 and the rising wall portion 25 from the joint to the inclined wall portion 24. Further, even when there is exerted a force which allows the inclined wall portion 24 to move outside the bottle 10, with an edge portion opposite to the joint of the inclined wall portion 24 being used as a supporting point, the rising wall portion 25 acts against the force, thereby the inclined wall portion 24 is not deformed so

as to move outside the bottle 10. Therefore, even if there is an increase in internal pressure of the bottle 10, it is possible to prevent the concentration of stress on a specific site at the outer circumference brim of the annular wall portion 23.

5 As a result, it is possible to improve the compressive strength of the bottom 11 of the bottle 10 and also prevent the base portion 21 continuing to the outer circumference brim of the annular wall portion 23 from being deformed so as to swell to the outside.

[0025] Further, since the rib 27 is provided with the inclined wall portion 24, the annular wall portion 23 is not complicated in configuration. Therefore, the inside of the bottle can be sufficiently cleaned before a liquid or the like is filled into the bottle 10. Still further, since a cleaning liquid can easily flow along the inclined wall portion 24, the cleaning liquid can be easily discharged from the bottle 10 to prevent a decrease in the handling property of the bottle 10.

[0026] Further, in the present embodiment, each of the ribs 27, which is provided with the inclined wall portion 24 and the rising wall portion 25, continues to the base portion 21 via the step portion 26. Therefore, when the bottle 10 is produced by blow molding, a poor configuration of the bottle 10 can be prevented even when a mold is worn.

Where the above angle $\theta 1$ is smaller than 45 degrees, the rib 27 is expanded in the circumferential direction of the bottle 10 and crushed more easily. Further, where the angle $\theta 1$ is larger

than 90 degrees, the bottle 10 is inferior in molding property.

[0027] Next, an explanation will be given for Embodiment 2 of the present invention. It is noted that the same parts as those of Embodiment 1 are given the same symbols and numerals and
5 explanations thereof are omitted, with only different parts being explained here.

[0028] As illustrated in FIG. 5, in the present embodiment, a rising wall portion 31 constituting the rib 27 together with the inclined wall portion 24 is formed at the annular wall portion
10 23. When the rib 27 is viewed from below in the direction of the central axis line O, the upper brim 31a of the rising wall portion 31 is extended in a direction which is inclined in a radial direction to the bottom 11 of the bottle 30. In other words, the upper brim 31a of the rising wall portion 31 is
15 extended in a direction inclined to a line L which connects a point at which the rising wall portion 31 is in contact with the base portion 21 with the center (central axis line O) of the bottle 30. In FIG. 5, the rising wall portion 31 of each rib 27 is extended so as to be spaced from the line L gradually
20 in a counterclockwise direction as it moves from the base portion 21 to the central recess 22. It is noted that an angle θ_3 made by a direction at which the upper brim 31a of the rising wall portion 31 is extended and the line L is set to be, for example, 30 degrees or less and preferably 15 degrees or less. The angle
25 θ_3 may be changed, whenever necessary, depending on the number

of the ribs 27 or the like. In the present embodiment, the angle θ_3 is set to be approximately 8 degrees.

[0029] As described so far, according to the present embodiment, the upper brim 31a of the rising wall portion 31 is extended
5 in a direction inclined to the line L. Therefore, even when a force is exerted which allows the inclined wall portion 24 to move outside the bottle 30, with an edge portion opposite to the joint of the inclined wall portion 24 being used as a supporting point due to an increase in internal pressure of the
10 bottle 30, the inclined wall portion 24 is deformed so as to cover the rising wall portion 31 and the rising wall portion 31 stops the force, thereby preventing the rib 27 from being expanded in a circumferential direction and deformed so as to be crushed. Therefore, it is possible to further improve the
15 compressive strength of the bottle 30.

[0030] It is noted that the technical scope of the present invention is not limited to the above Embodiment 1 and Embodiment 2 but can be modified in various ways as long as it is not deviated from the scope of the present invention.

20 In the above embodiments, an explanation was made for the bottles 10, 30, the transverse cross section is substantially circular, for example. It is, however, acceptable that the bottle is such that, the transverse cross section of which is substantially rectangular.

25 Further, in the above embodiments, the step portion 26

is formed at the bottom 11. It is also acceptable that the step portion 26 is not formed but the edge portion of the inclined wall portion 24 located outside the bottom 11 in a radial direction and the edge portion of the rising wall portion 25 (or 31) located in the radial direction are directly connected to the base portion 21.

[0031] In the above embodiments, a joint between the inclined wall portion 24 of each rib 27 and the rising wall portion 25 is formed so as to give a ridge, while a joint between the inclined wall portion 24 with an adjacent rib 27 and the rising wall portion 25 is formed so as to form a valley. However, it is acceptable that, for example, a flat-face portion is formed between the inclined wall portion 24 and the rising wall portion 25 and the inclined wall portion 24 is connected with the rising wall portion 25 via the flat-face portion.

[0032] In the above embodiments, as illustrated in FIG. 3, the inclined wall portion 24 is inclined from the base portion 21 to the central recess 22 and also curved so as to be recessed to the inside of the bottle 10. However, the inclined wall portion 24 may be curved so as to protrude outside the bottle 10 or inclined in a flat face shape.

Further, in the above embodiments, as illustrated in FIG. 4, the inclined wall portion 24 is formed in a flat-face shape and inclined from the lower brim of the rising wall portion 25 of an adjacent rib 27 toward the upper brim 25a of the rising

wall portion 25 to give the rib 27 in combination with itself. However, the inclined wall portion 24 may be curved so as to be recessed to the inside of the bottle 10 or may be curved so as to protrude outside the bottle 10.

5 [0033] In each of the above embodiments, the inclined wall portion 24 and the rising wall portion 25 (or 31) may be changed in position toward the circumferential direction of the bottle so that they can be exchanged with each other.

[0034] Next, a numerical analysis was carried out to verify the
10 above-described actions and effects. The bottle 10 of Embodiment 1 was adopted as Example 1, and the bottle 30 of Embodiment 2 was adopted as Example 2. As a comparative example of Example 1, the bottle 10 of Embodiment 1 is adopted which is not provided with the inclined wall portion 24 or the rising
15 wall portion 25. As a comparative example of Example 2, the bottle 30 of Embodiment 2 is adopted which is not provided with the inclined wall portion 24 or the rising wall portion 31.

Then, an internal pressure determined when the internal pressure was imparted to each of the bottles and the base portion
20 21 was deformed so as to swell outwardly was evaluated as a compressive strength.

[0035] As a result, each of the comparative examples was 0.147 MPa in compressive strength, whereas Example 1 was 0.333 MPa and Example 2 was 0.363 MPa. In other words, it was confirmed
25 that Example 1 and Example 2 were improved in compressive

strength two times or more than the comparative examples.

INDUSTRIAL APPLICABILITY

[0036] The present invention relates to a bottle, which is
5 provided with a base portion installed on the outer circumference
brim of the bottom, a central recess installed inside the base
portion and recessed toward the inside of the bottle, an annular
wall portion installed between the base portion and the central
10 recess and inclined so as to gradually elevate from the base
portion to the central recess, and a plurality of ribs installed
side by side at the annular wall portion in the circumferential
direction of the bottom and protruding toward the inside of the
bottle, in which the ribs are provided with a rising wall portion
15 rising toward the inside of the bottle and an inclined wall
portion inclined from the upper brim of the rising wall portion
toward the lower brim of the rising wall portion of an adjacent
rib, and the rising wall portion is inclined more steeply than
the inclined wall portion.

According to the present invention, it is possible to
20 provide a sufficient compressive strength at the bottom of the
bottle, without decreasing the handling property even when the
bottle is made lighter in weight.

CLAIMS

[1] A bottle comprising:

a base portion installed on the outer circumference
brim of a bottom of the bottle;

a central recess installed inside the base portion
and recessed toward the inside of the bottle;

an annular wall portion installed between the base
portion and the central recess and inclined so as to elevate
gradually from the base portion to the central recess; and

a plurality of ribs installed side by side at the
annular wall portion in the circumferential direction of the
bottom of the bottle and protruding toward the inside of the
bottle; wherein

the ribs are provided with a rising wall portion
rising toward the inside of the bottle and an inclined wall
portion inclined from the upper brim of the rising wall
portion toward the lower brim of the rising wall portion of
an adjacent rib, and

when the bottom of the bottle is viewed from the
cross section along the circumferential direction, an angle
 θ_1 made by an outer surface of the rising wall portion and
an outer surface of the base portion is 45 to 90 degrees,
and an angle θ_2 made by an outer surface of the inclined
wall portion and an outer surface of the base portion is 5
to 45 degrees.

[2] The bottle according to Claim 1, wherein

when the bottom is viewed from below in the direction of the central axis line of the bottle, the upper brim of the rising wall portion is inclined to the bottom in a radial direction.

[3] The bottle according to claim 1 and claim 2, wherein the angle θ_1 is 60 to 75 degrees, and the angle θ_2 is 15 to 30 degrees.

[4] The bottle according to any one of the preceding claims, wherein

the rising wall portion is formed in a triangular shape and the inclined wall portion is formed in a fan shape.

[5] A bottle, substantially as herein described with reference to the attached Figures.

FIG. 1

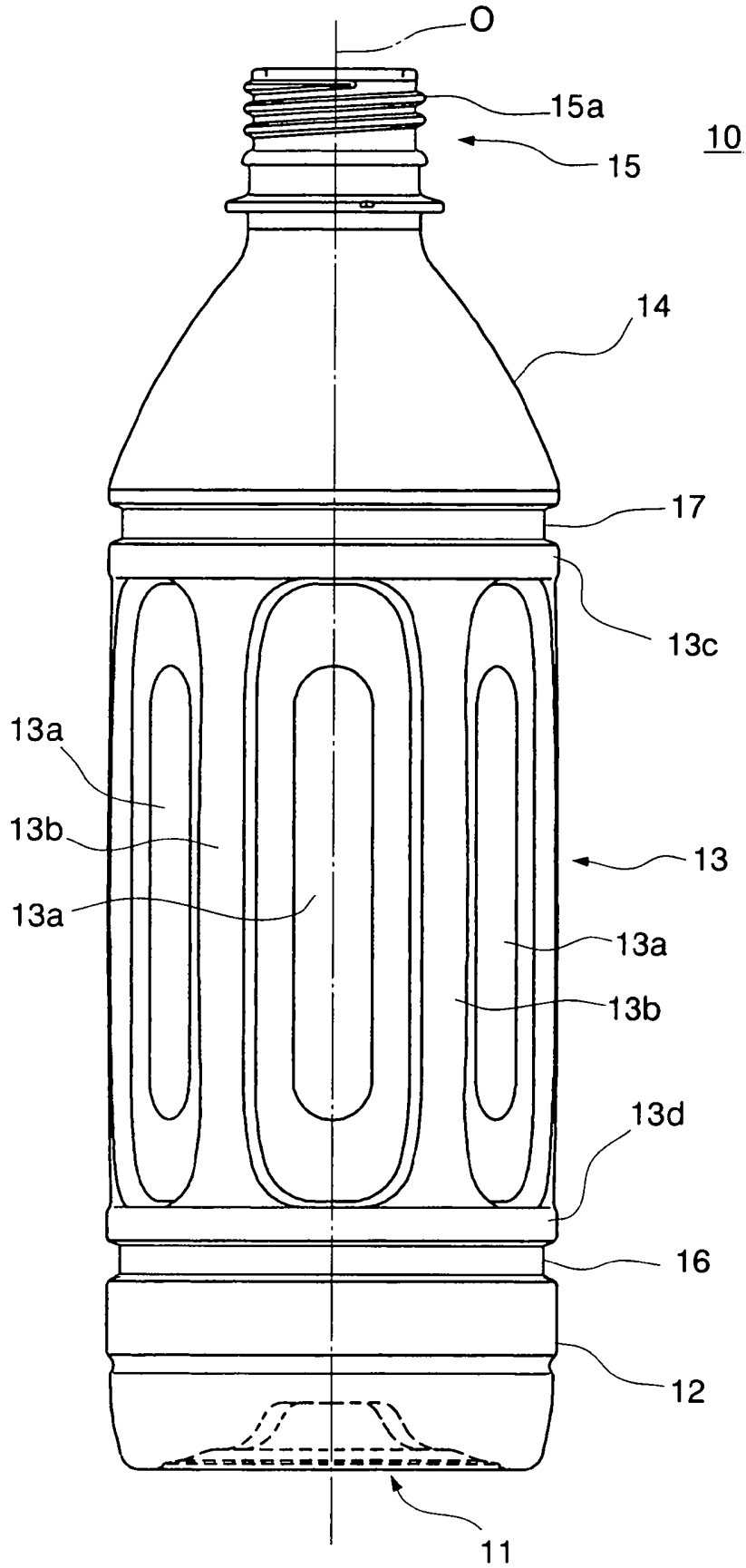

FIG. 2

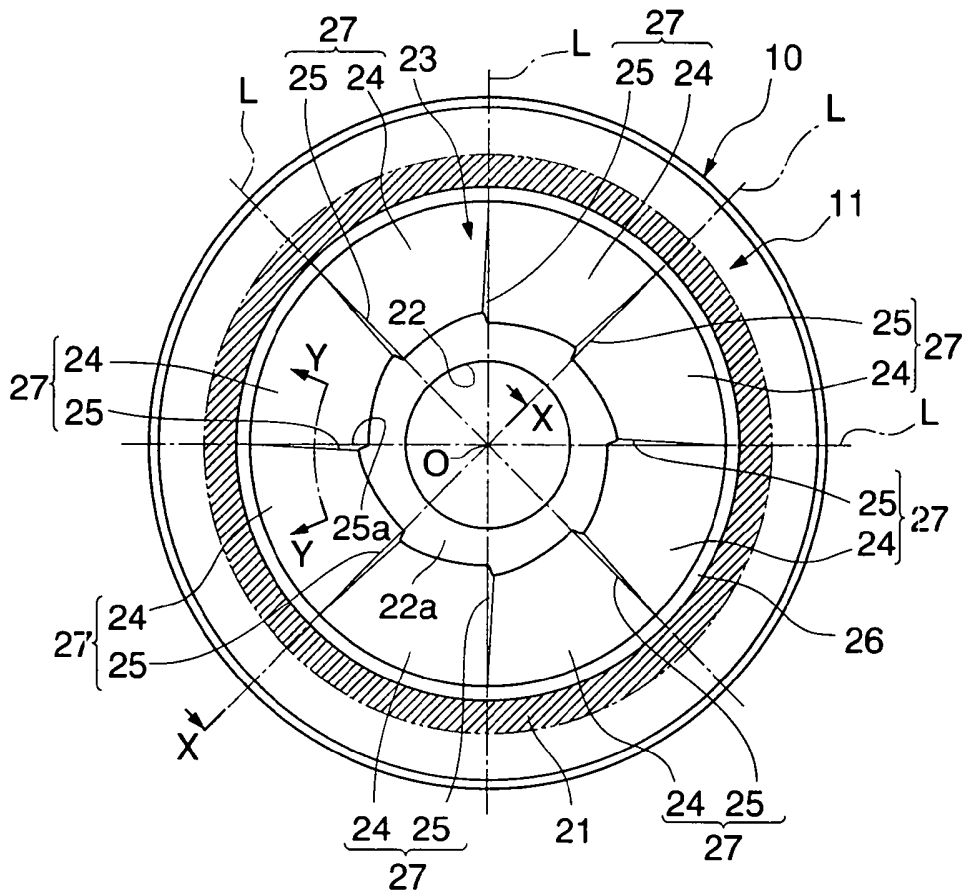

FIG. 3

