

C. C. WORTHINGTON.
PUMP.

(Application filed Oct. 4, 1898.)

(No Model.)

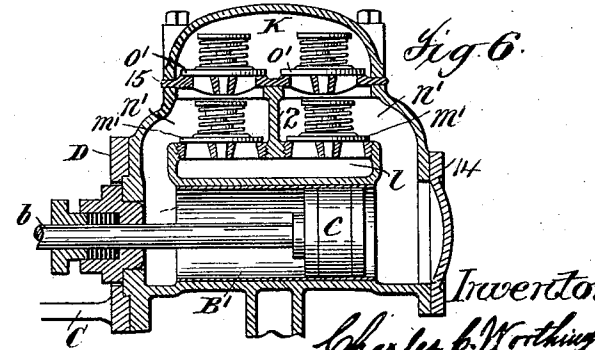
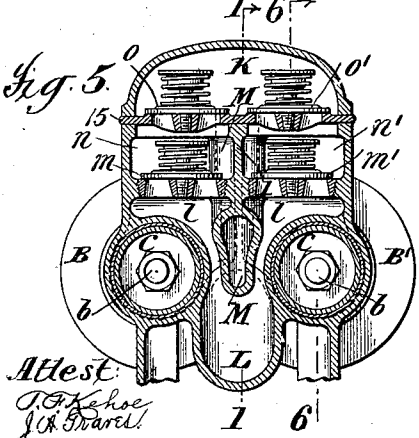
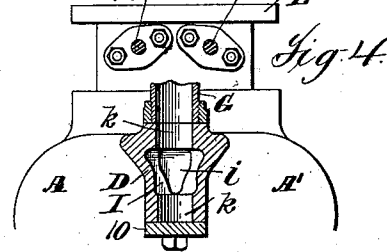
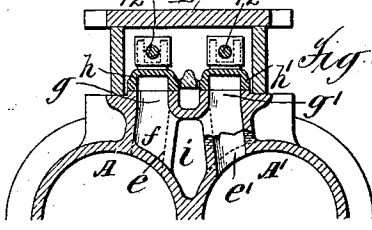
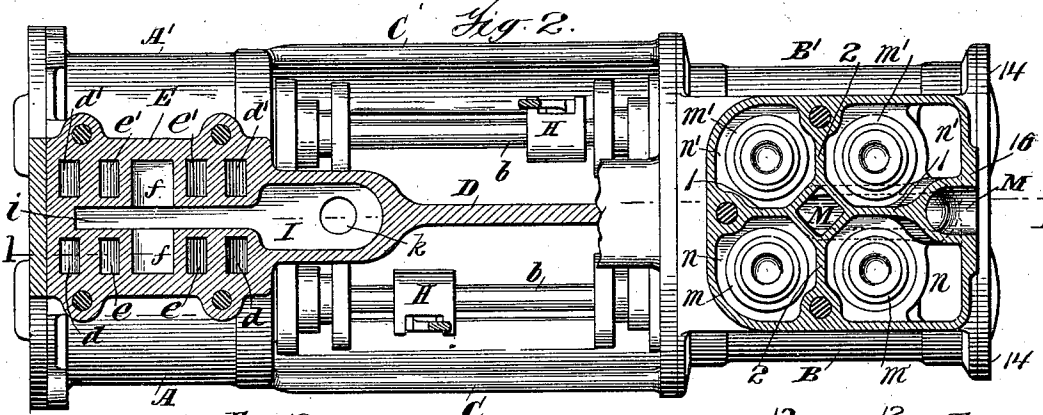
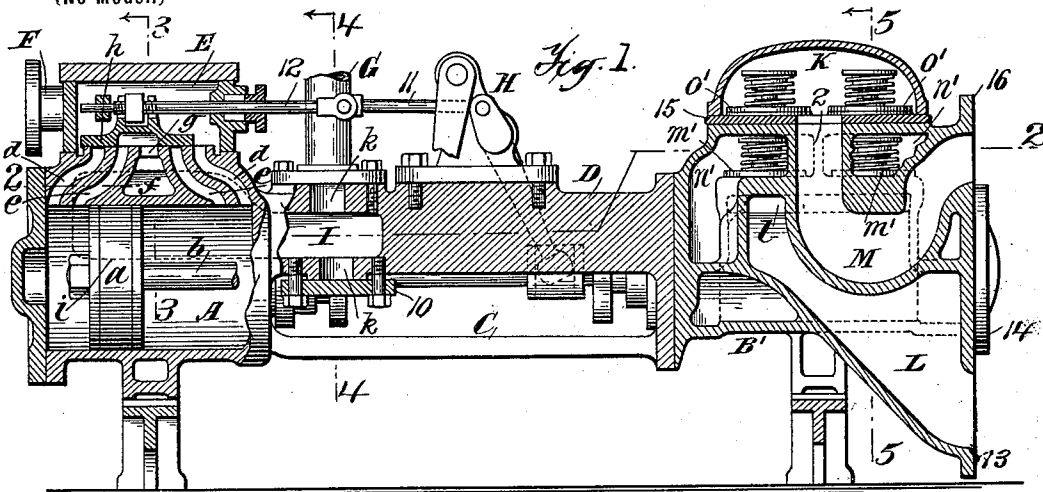

Attest:
J. G. Ketcher
J. C. Board

Inventor
Charles C. Worthington
By Philip Phillips
Attorney

UNITED STATES PATENT OFFICE.

CHARLES C. WORTHINGTON, OF IRVINGTON, NEW YORK.

PUMP.

SPECIFICATION forming part of Letters Patent No. 657,976, dated September 18, 1900.

Application filed October 4, 1898. Serial No. 692,660. (No model.)

To all whom it may concern:

Be it known that I, CHARLES C. WORTHINGTON, a citizen of the United States, residing at Irvington, county of Westchester, and State of New York, have invented certain new and useful Improvements in Pumps, fully described and represented in the following specification and the accompanying drawings, forming a part of the same.

This invention relates especially to duplex steam-pumps, the chief object of the invention being to provide an improved construction of this class which shall be of such compact form as to secure a high capacity with a pump of small size, and, further, to provide such a pump which shall be simple, cheap, and durable in construction, convenient for forming the required pipe connections, and which shall present an improved appearance over such pumps now in use.

In attaining the objects above stated I have made certain improvements in the water end of the pump, and the invention includes certain features in the construction of duplex-pump cylinders and their chambers and connections, all as fully described hereinafter and specifically pointed out in the claims.

For a full understanding of the invention a detailed description of a construction embodying all the features of the invention in their preferred form as applied to a duplex direct-acting steam-pump of a well-known class will now be given in connection with the accompanying drawings, in which—

Figure 1 is a vertical longitudinal section of the pump, taken on the line 1 of Figs. 2 and 5. Fig. 2 is a horizontal section on the line 2 of Fig. 1. Figs. 3 and 4 are vertical cross-sections of the steam end on the lines 3 and 4 of Fig. 1. Fig. 5 is a vertical cross-section on the line 5 of Fig. 1. Fig. 6 is a vertical longitudinal section on the line 6 of Fig. 5.

Referring to the drawings, A A' are the steam-cylinders on opposite sides of the engine, and B B' the corresponding water-cylinders. The steam and water cylinders are preferably connected, as shown, by the side frames C and central frame-piece D, formed integral with the steam end and connected to the water end by the usual flange connection, the central frame-piece D forming the cradle on which the valve-movement is mounted and

through which the steam exhausts, as described hereinafter. The steam-cylinders A A' on opposite sides of the engine and the cradle D are preferably formed integral, as shown, so that a single casting forms the steam end and cradle, with the exception of the valve-chest.

The steam-cylinders are shown as having the usual pistons *a*, connected by piston-rods *b* directly to the pump-plungers *c* on opposite sides of the engine, and the usual induction-ports *d d'* and exhaust-ports *e e'* for the respective cylinders A A', communicating, respectively, with the single steam-chest E on top of the cylinders and with the exhaust-cove *f* by exhaust-ports *g g'*, all these ports being shown as controlled for admission and exhaust by the D slide-valves *h h'* on the respective cylinders, although it will be understood that the form and arrangement of these valves and ports may be varied as desired.

It will be understood that the valves *h h'* may be actuated by any suitable movement. As shown, they are actuated by the usual crossover valve-movement H, mounted on the cradle D, as previously described, and connected to the valves *h h'* by links 11 and valve-rods 12, so that the valve on each side is operated from the other side of the engine, as usual in duplex direct-acting engines of the class shown. The induction-pipe F may be and is shown as connected directly with the steam-chest E at the end of the pump, as usual in such constructions.

The exhaust-cove *f*, which extends across both ports *g g'*, as shown in Figs. 2 and 3, connects centrally with an exhaust-passage *i*, which preferably is made narrow horizontally, as shown, for compactness of construction, and extends downward between the steam-cylinders A A' and toward the pump end, opening beyond the cylinder ends into a chamber I, shown as formed by an extension of the cylinder-casting and enlargement of the cradle D. With this chamber I the exhaust-pipe G connects by port *k*. The port *k* preferably opens vertically from the chamber I, either upward or downward; but it will be understood that this may be varied. As shown, the pipe G is above the chamber and a second port *k* opens downward from the chamber I, and this construction is preferably

used, so that the exhaust-pipe G may extend either upward or downward, as may be found more desirable in setting up the pump, the port *k* to which the exhaust-pipe G is not connected being then closed in any suitable manner, as by a cover 10, shown on the lower port *k* in the drawings.

Referring now to the water end of the pump, the water-cylinders B B' on opposite sides are preferably cast integral with each other and with the pulsation-chambers and suction and force passages, as shown, a very compact, cheap, and durable construction being thus provided, which in itself forms a specific part of the invention; but it will be understood that the broader features of the invention are not limited to this integral construction.

The suction-passage L for both cylinders B B' extends upward from below in a plane between the cylinders, so that its flange 13 for connection with the suction-main is at the end of the pump below and between the cylinder-heads 14, and this suction connection L expands horizontally above the cylinders into a broad suction-chamber *l*, preferably of small depth, as shown, from which the suction passes through suction-valves *m m'* for the respective cylinders, which valves may be of any common or suitable form, into the respective pulsation-chambers *nn* and *n' n'* for the opposite ends of the respective pump-cylinders and opening downward into the latter. These chambers are formed by the longitudinal and transverse partitions 1

2. Above the pulsation-chambers *n n'* and formed, as shown, by a separate hood-casting bolted onto the top of the cylinder construction is the force-chamber K, into which the fluid is forced through force-valves *o o'* for the respective cylinders, which may be of any common or suitable form. These valves *o o'* are mounted on the valve-plate 15, and the force-passage M opens through this valve-plate centrally between the valves *o o'* and extends down through the casting of the cylinder construction centrally between the pulsation-chambers *n n'* and valves *m m'*, its walls being formed by portions of the partitions 1 2. Below the pulsation-chambers it passes downward as a pipe through the suction-chamber *l* and between the cylinders, where it is contracted sidewise and expanded vertically to secure the desired capacity with compactness in the arrangement of the cylinders and force-passage and then extends upward, resuming its circular form, and passes between the rear pulsation-chambers *nn'* and then outward to the end of the pump, with its connecting-flange 16 above and between the cylinder-heads 14 and in line with the flange 13 of the suction-passage L, thus bringing all the flanges for the cylinder-heads and suction and force connections into the most convenient position for rapid and accurate facing in manufacture.

As shown, four suction and force valves are used, one for each pulsation-chamber, and

the force-passage M is formed square where it passes between the valves, so as to secure the most compact arrangement of valves and force-passage. It will be understood, however, that the number of valves may be varied and that the force-passage may be of other form. The suction-passage, however, will preferably be made angular in cross-section to correspond with the number of valves employed for compactness of construction.

It will be seen that my invention provides a very simple, convenient, and compact duplex-pump cylinder construction.

While the features forming the present invention are preferably used in a duplex direct-acting steam-pump, as shown, one object of the present invention being to provide such a pump of very small size for its capacity, it will be understood that my improvements in the pump end may be used in any class of pump, with the pump-plungers operated directly by steam-pistons or in any other manner. It will be understood, also, that modifications in the construction shown may be made by those skilled in the art without departing from the invention and that I am not to be limited to the exact form or arrangement of parts shown in the drawings.

What I claim is—

1. A pump having two pump-cylinders arranged side by side with the force-chamber above the pulsation-chambers and the force-passage extending downward centrally between the pulsation-chambers and suction-valves to a plane below the suction-valves and then upward and outward to open at the end of the pump above and in a plane between the cylinders.

2. A pump having two pump-cylinders arranged side by side with the force-chamber above the pulsation-chambers, the suction-passage entering at the end of the pump below and in a plane between the cylinders and passing upward between the cylinders to form a suction-chamber above and between the cylinders below the pulsation-chambers, and the force-passage extending downward centrally between the pulsation-chambers and suction-valves to a plane below the suction-valves and then upward and outward to open at the end of the pump above and in a plane between the cylinders.

3. A pump having two pump-cylinders arranged side by side with the force-chamber above the pulsation-chambers and the force-passage extending downward centrally between the pulsation-chambers and suction-valves into the suction-chamber and between the cylinders and then upward and outward to open at the end of the pump above and in a plane between the cylinders.

4. A pump having two pump-cylinders arranged side by side with the force-chamber at the top of the pump and the force-passage extending downward centrally between the suction-valves of the two cylinders to a plane below the valves and then to the discharge.

5. A pump having two pump-cylinders arranged side by side with the force-chamber at the top of the pump and the force-passage extending downward centrally between the valves of the two cylinders to a plane below the valves and between the cylinders and then to the discharge.

6. A pump having two pump-cylinders arranged side by side with the force-chamber at the top of the pump and the force-passage extending downward centrally between the valves of the two cylinders to a plane below the valves and between the cylinders and then to the discharge, said passage being flattened between the cylinders for securing a compact arrangement of the passage and cylinders.

7. A pump having the cylinders B, B', pulsation-chambers *n, n'* and force-chamber K, suction-valves *m, m'* force-valves *o, o'* above the suction-valves *m, m'*, suction-passage L extending upward from the end of the pump between the cylinders and forming suction-chamber *l*, above and between the cylinders, and force-passage M extending downward centrally between and below the valves and then outward to the discharge at the end of the pump, substantially as shown and described.

8. A pump having the cylinders B, B', pulsation-chambers *n, n'*, suction-passage L and chamber *l*, and central force-passage M extending downward centrally between the pulsation-chambers and then upward and outward to the discharge, all formed integral, substantially as shown and described.

9. In a pump having two cylinders, an inlet-chamber between the two cylinders and a suction-pipe connection at the back end and below the cylinder-heads, side walls and a horizontal plate above the suction-chamber and partitions above the horizontal plate,

there being openings and suction-valves in said horizontal plate, the partition separating the valve-chest into chambers that open into the ends of the pump-cylinders, a plate above the valve-chest having openings through it and force-valves and a downward discharge-opening through the plate communicating with a discharge-pipe and passing down through the valve-chamber and below the valves extending to the rear and terminating at the rear end of the pump and over the cylinder-heads, and a hood over the force-valves.

10. In a pump having two cylinders, an inlet-chamber between the two cylinders and a suction-pipe connection at the back end and below the cylinder-heads, side walls and a horizontal plate above the suction-chamber and partitions above the horizontal plate, there being openings and suction-valves in said horizontal plate, the partition separating the valve-chest into chambers that open into the ends of the pump-cylinders, a plate above the valve-chest having openings through it and force-valves and a downward discharge-opening through the plate, communicating with a discharge-pipe passing down through the valve-chamber and below the valves and extending to the rear and terminating with a connection for the discharge-pipe at the rear and over the cylinder-heads, and a hood over the force-valves and connecting-bolts for securing the same and the valve-plate to the valve-chest.

In testimony whereof I have hereunto set my hand in the presence of two subscribing witnesses.

CHARLES C. WORTHINGTON.

Witnesses:

B. W. PIERSON,
LOUIS R. ALBERGER.